

(PLAY EQ. AMPL.)

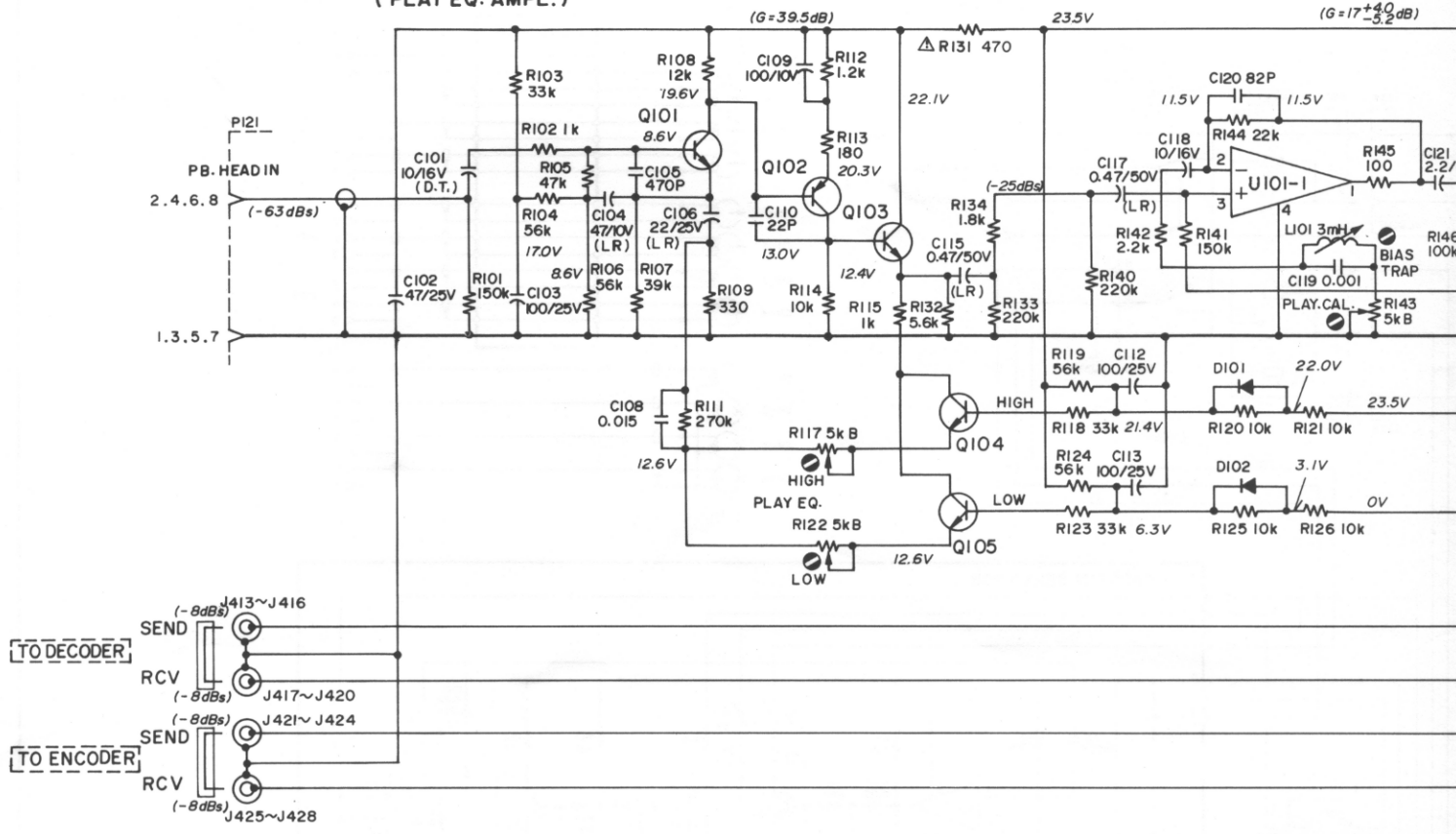

(SYNC. AMPL.)

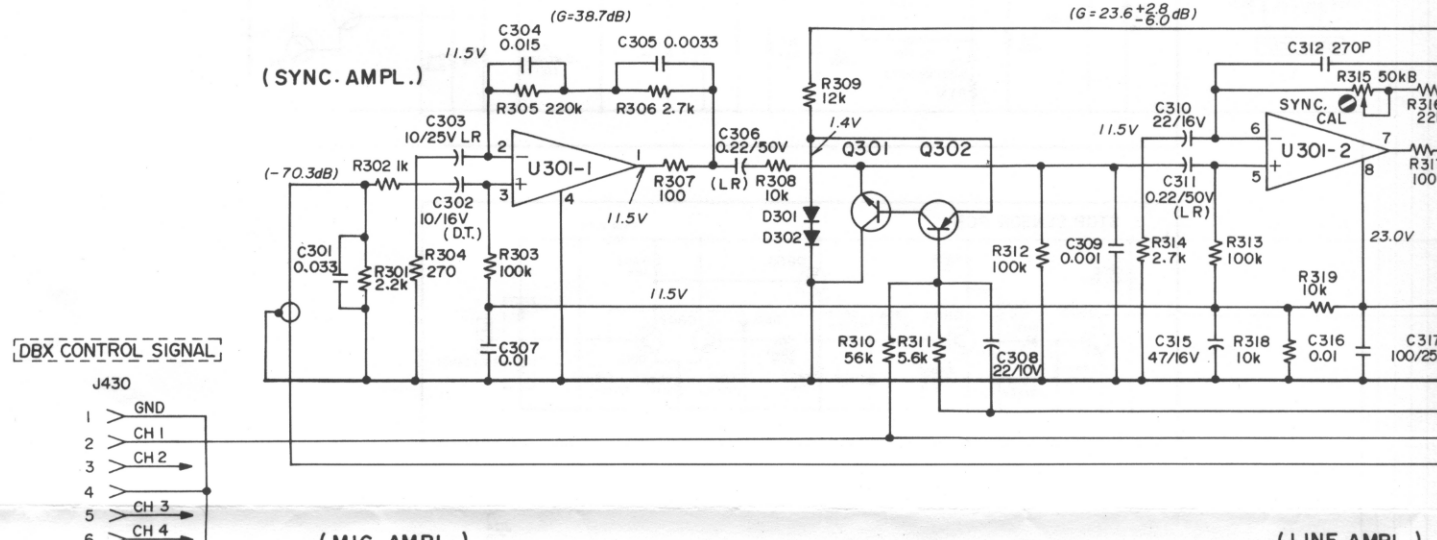

(MIC. AMPL.)

(LINE AMPL.)

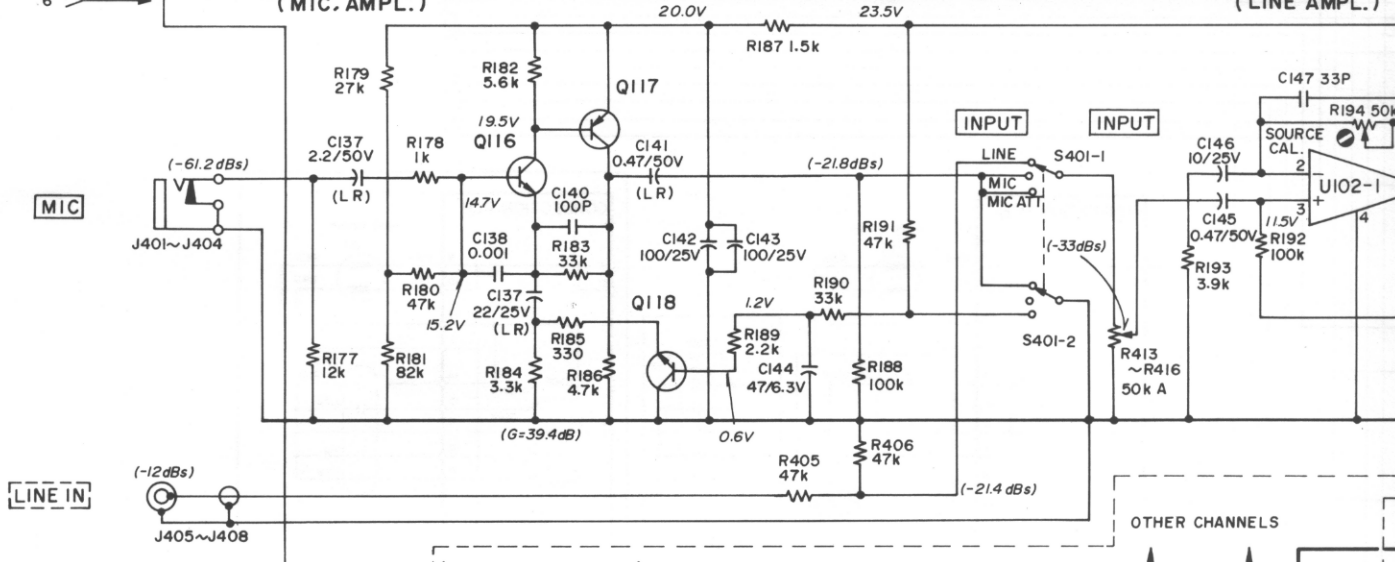

(FUNCTION RELAY)



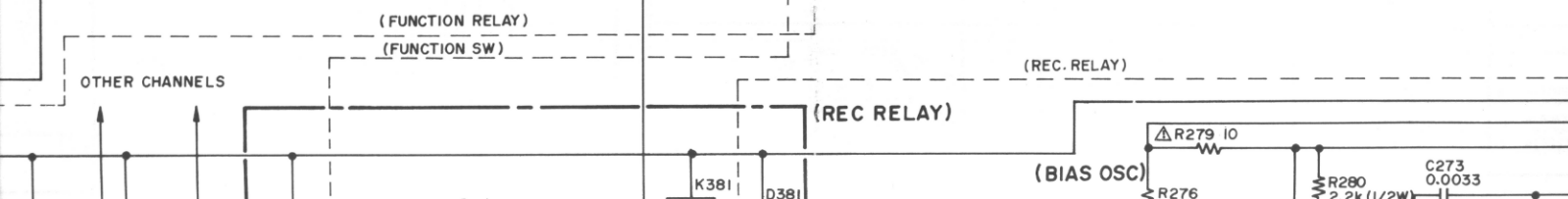
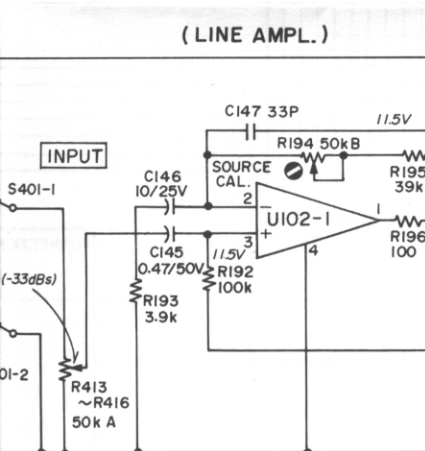
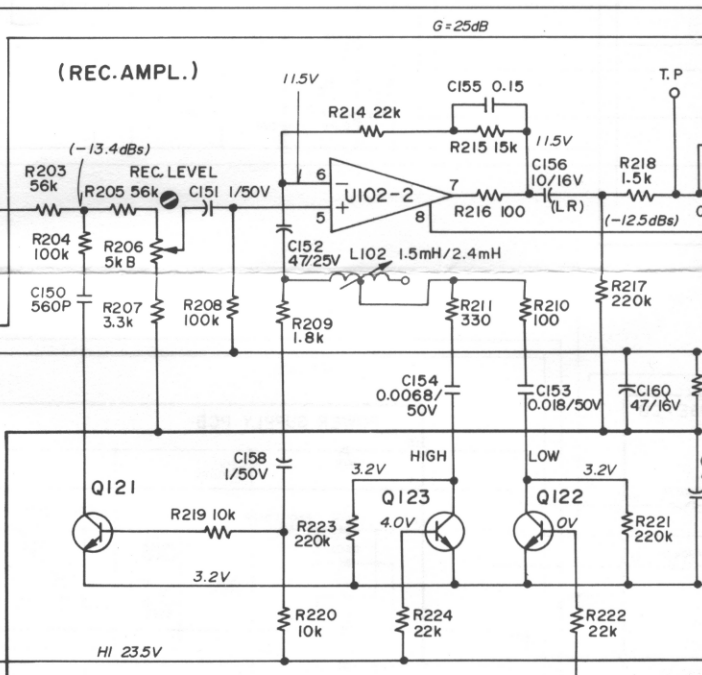
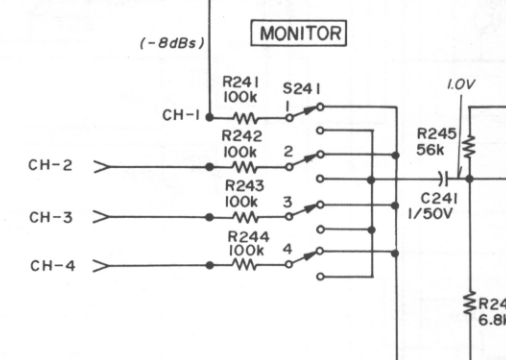
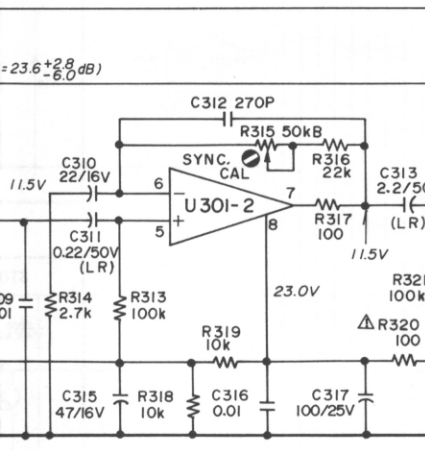
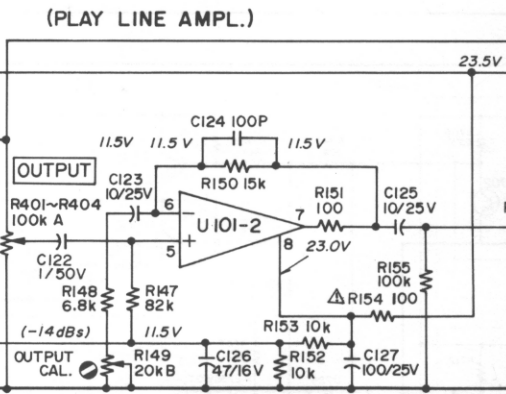
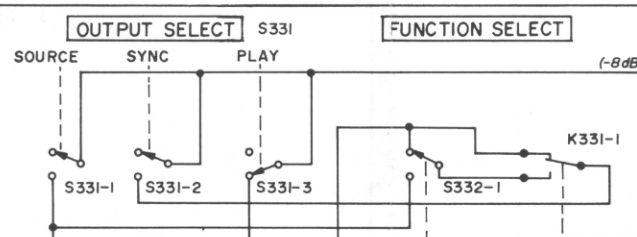
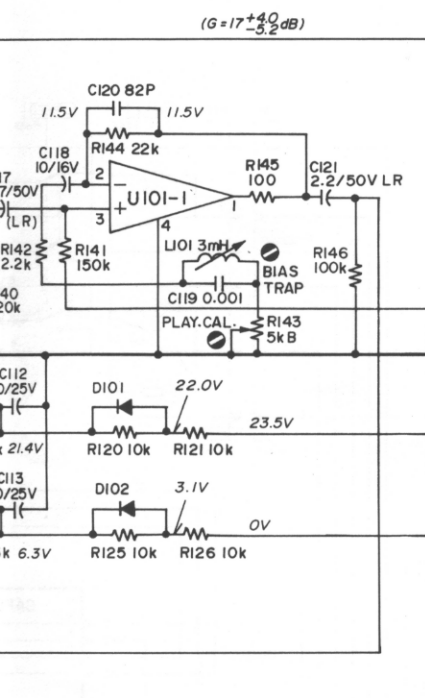

AMPL.)

(METER AMPL.)

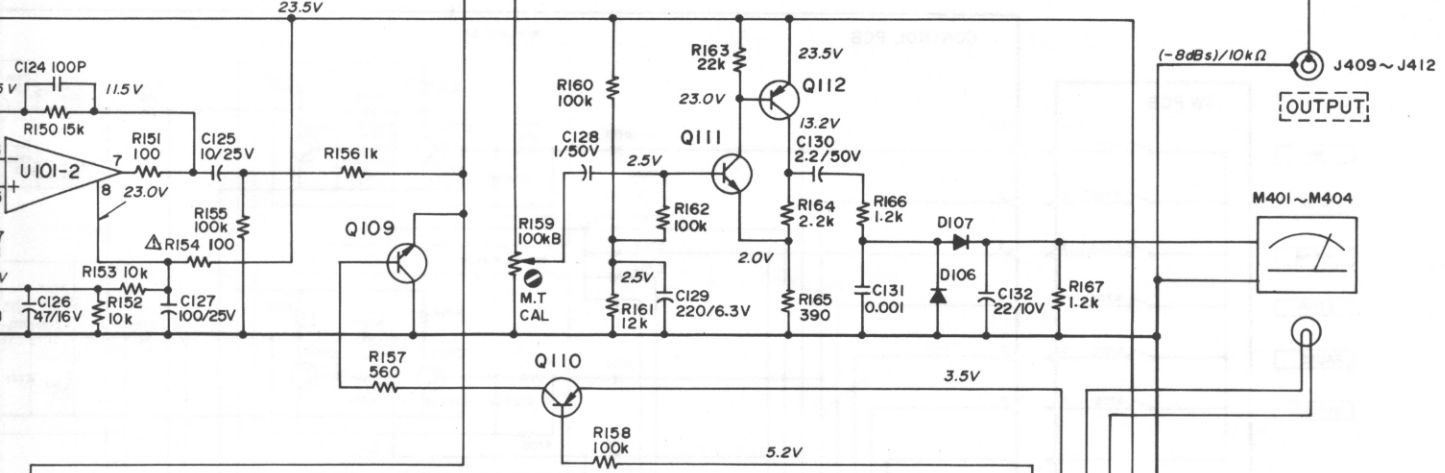

(PHONE AMPL. UNIT)

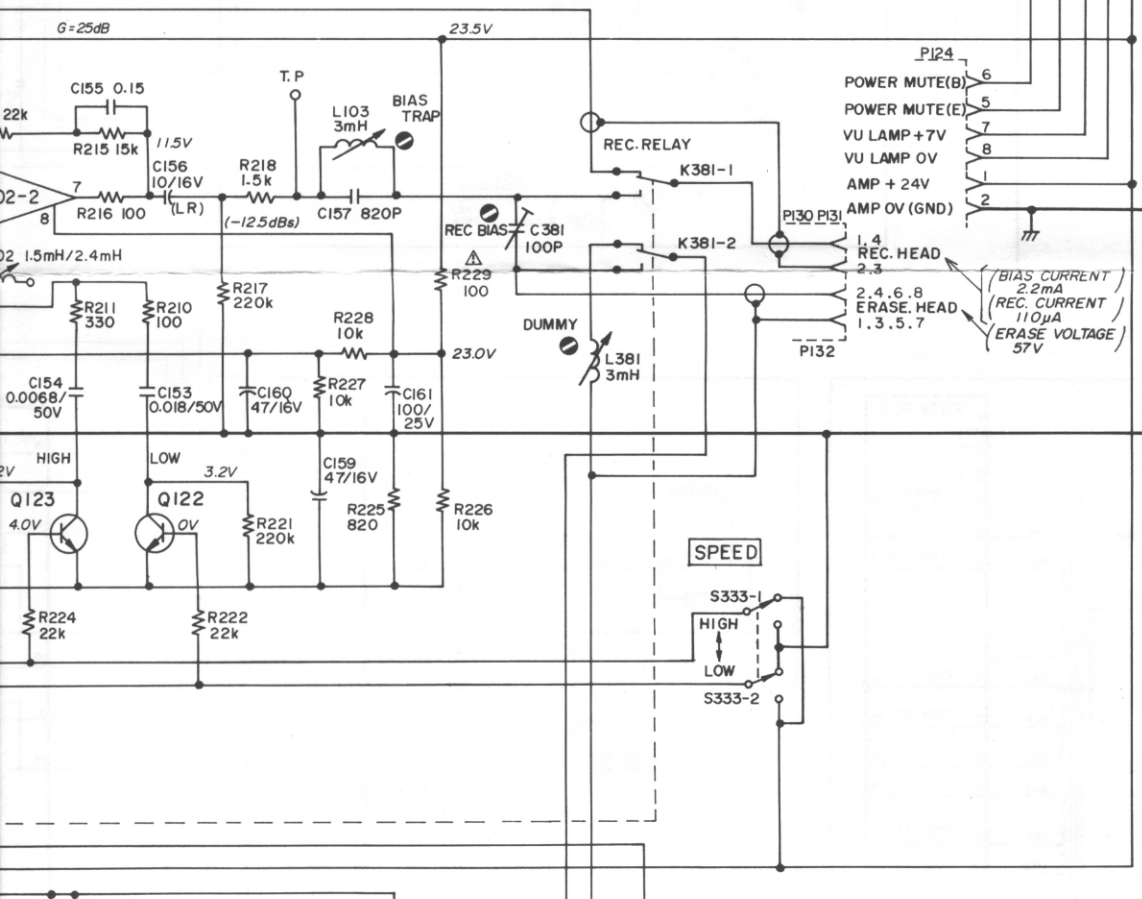
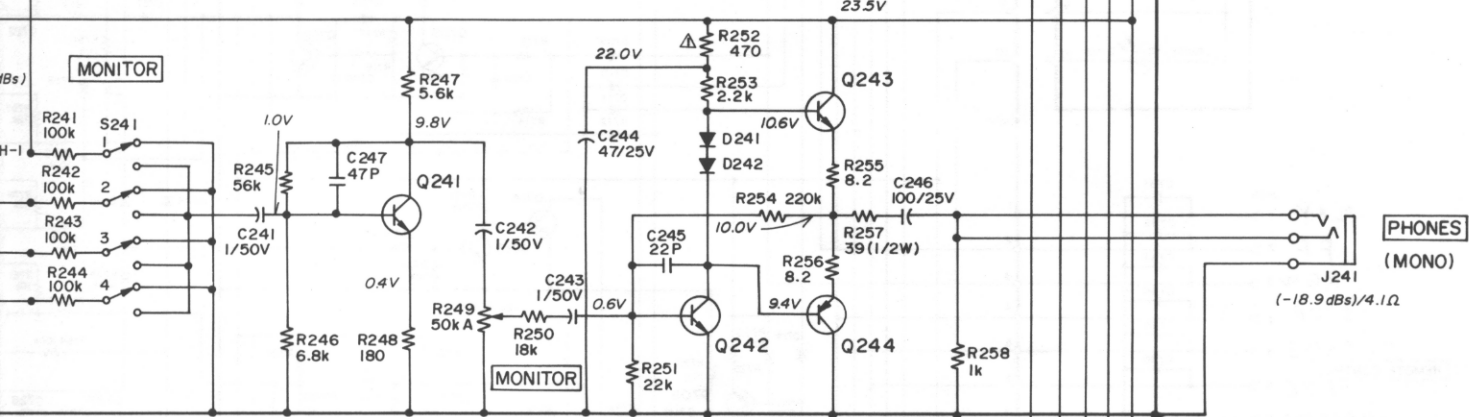

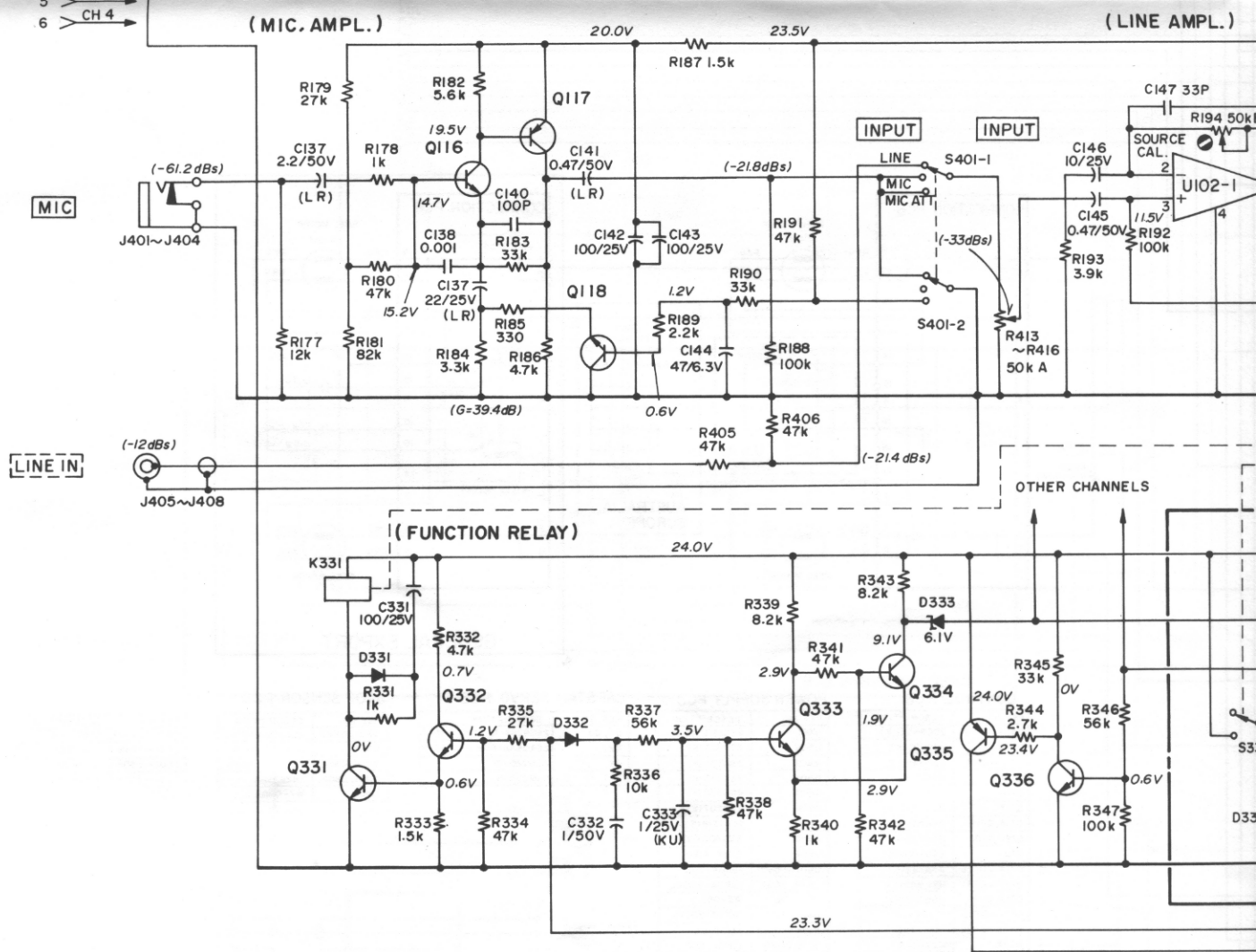

NOTES

SCHEMATIC DIAGRAM SHOWN IN THE STOP MODE.
 OUTPUT SELECT SWITCH SHOWN IN THE PLAY POSITION.
 TAPE SPEED SWITCH SHOWN IN THE HIGH POSITION.
 ALL RESISTORS ARE RATED $\pm 5\%$ TOLERANCE AND 1/4 WATT AND OF CARBON TYPE UNLESS OTHERWISE NOTED.
 ALL CAPACITORS VALUES IN MICROFARADS. P= PICOFARADS.
 Δ NON FLAMMABLE RESISTOR

REF.NO	DESCRIPTION
Q101	25C1327T
Q102	25A6661S
Q103	25C536F
Q104	25C1740LNS
Q105	25C1740LNS
Q109	25C1636-2
Q110	25A826LNS
Q111	25C1740LNS
Q112	25A826LNS
Q116	25C1222E

REF.NO	DESCRIPTION
Q117	25A6661S
Q118	25C1740LNS
Q121	25C1740LNS
Q122	25C1740LNS
Q123	25C1740LNS
Q241	25C1740LNS
Q242	25C1740LNS
Q243	25C2060Q
Q244	25A934Q
Q271	25C1740LNS

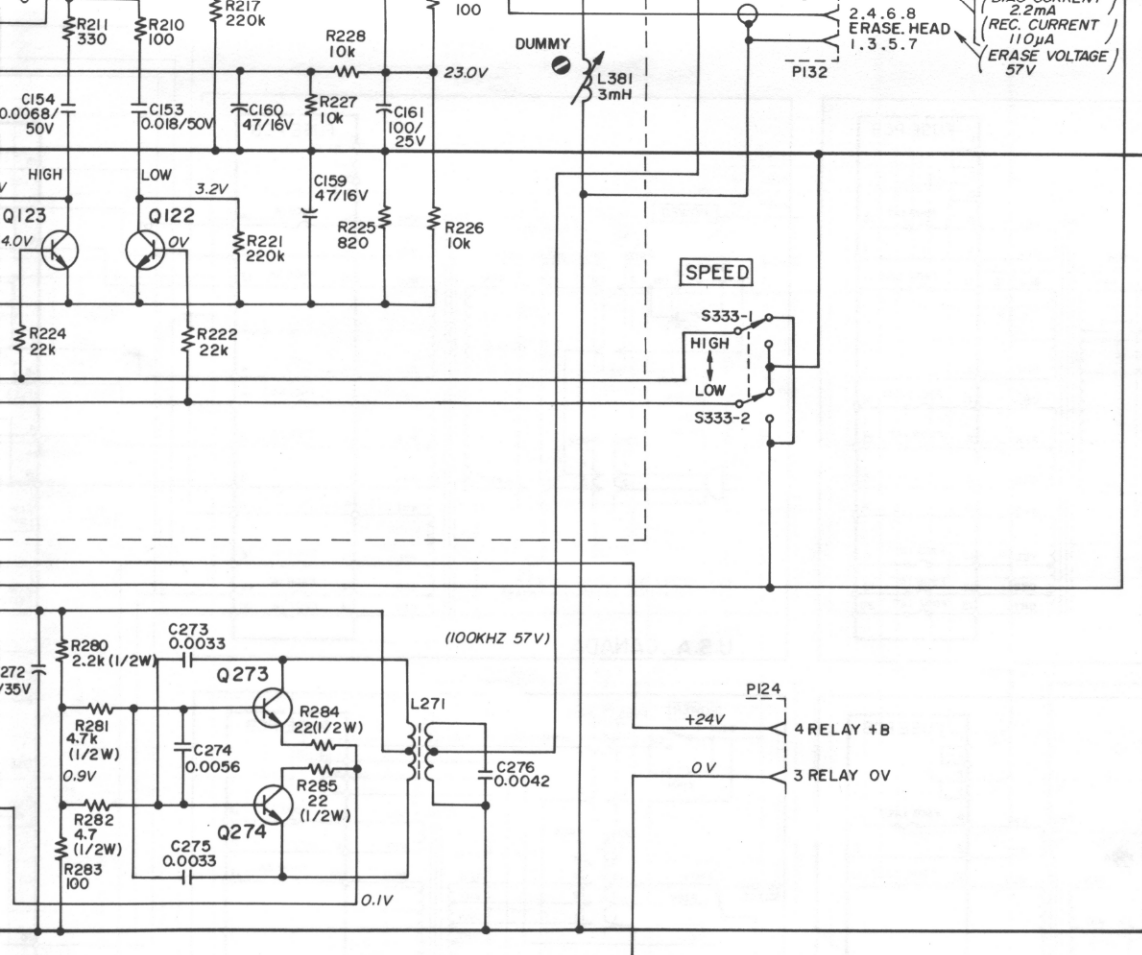

6		
5		
4		
3		
2		
1	06-78	EB-024
REVISION	DATE	CHANGE NO.

S-226

4-Channel Multitrack Tape Deck
with SIMUL-SYNC

MODEL NO. **A-3440** SHEET NO. /

TEAC CORPORATION

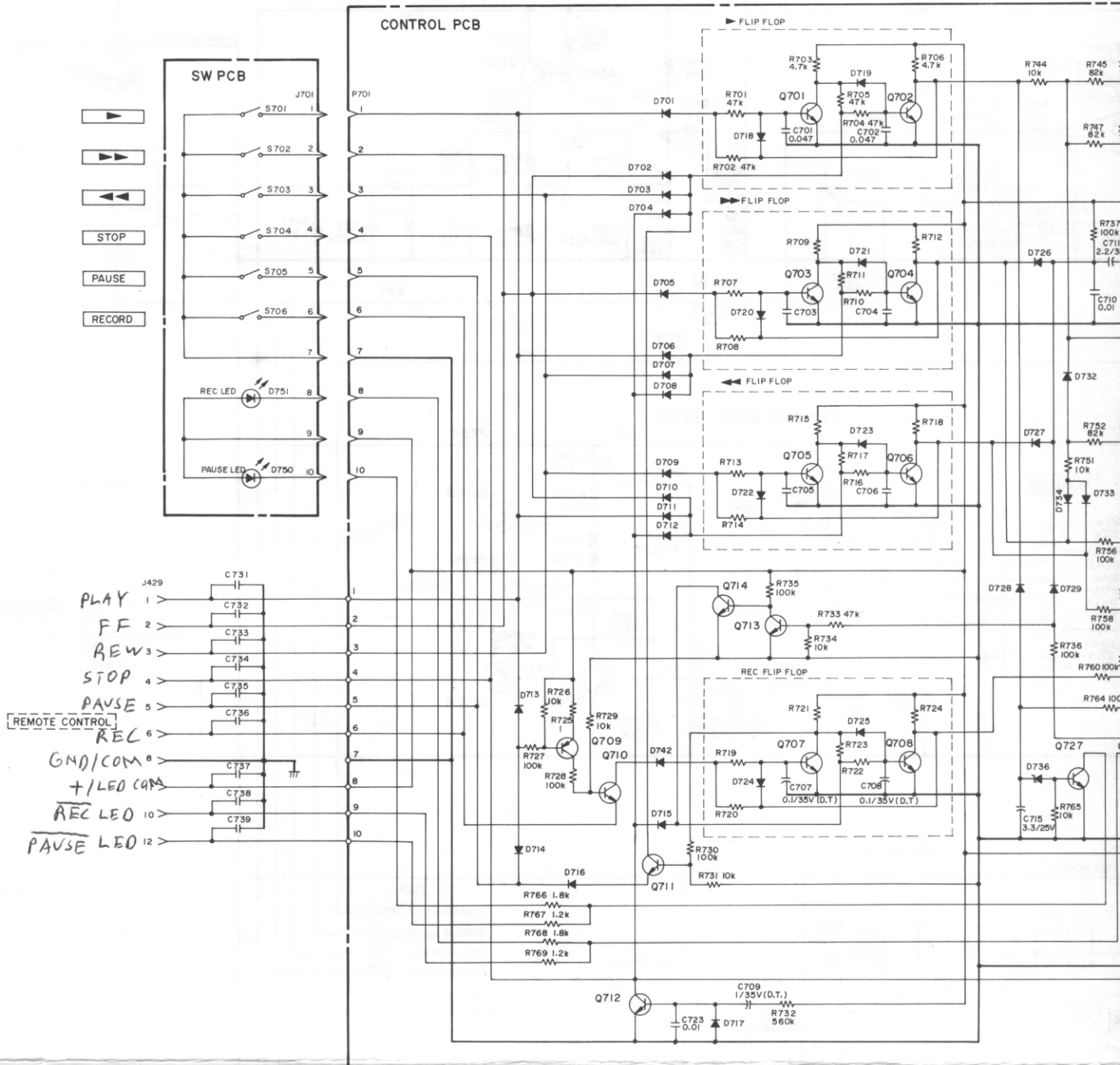

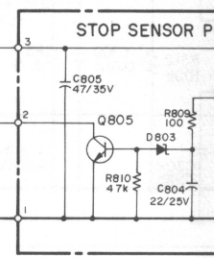
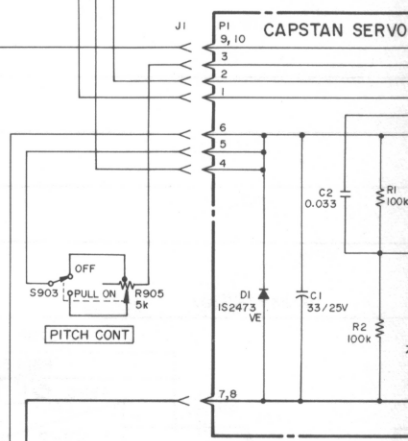
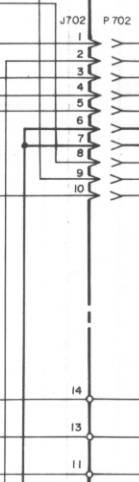
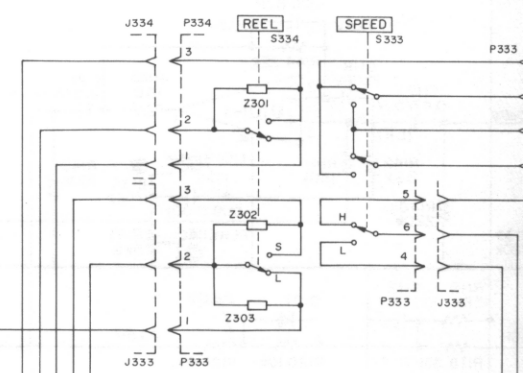
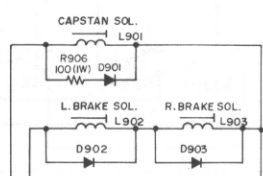
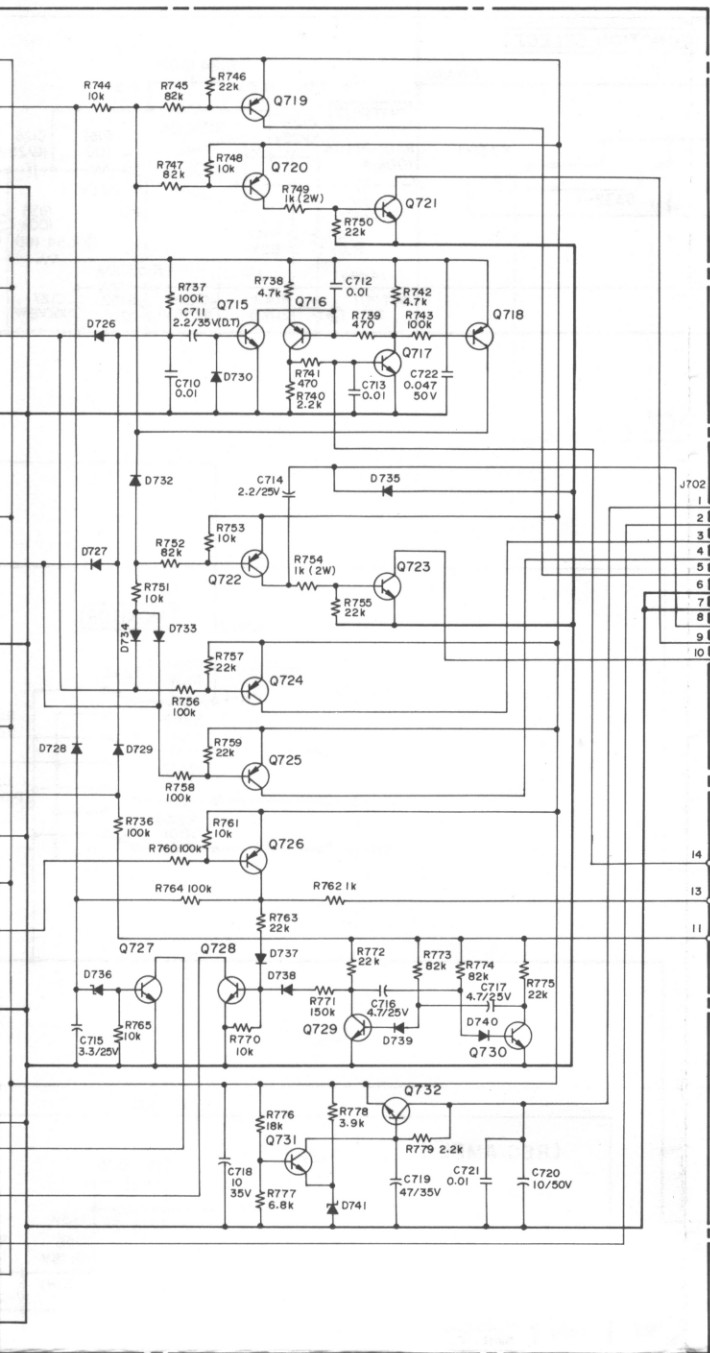

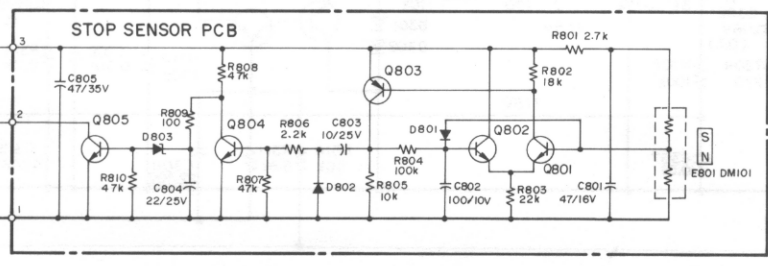
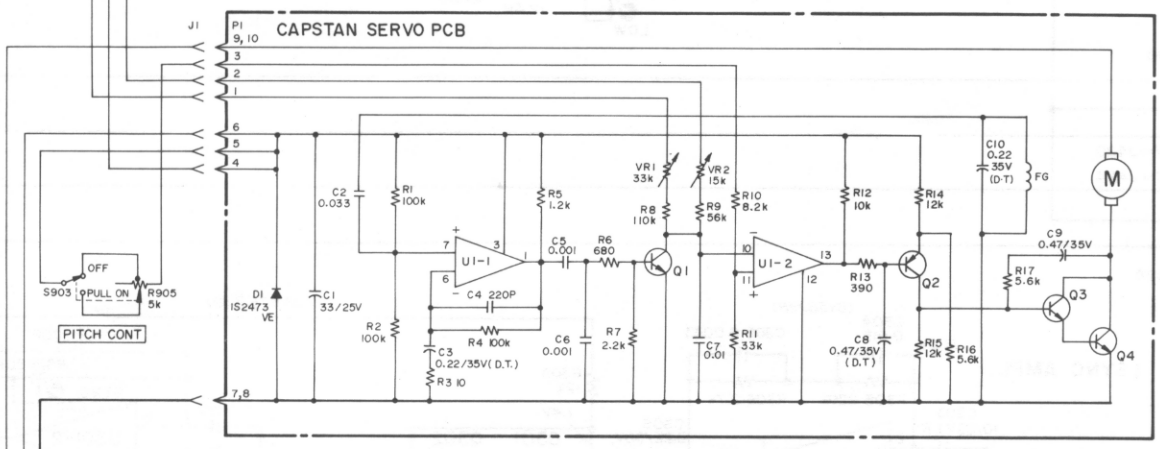
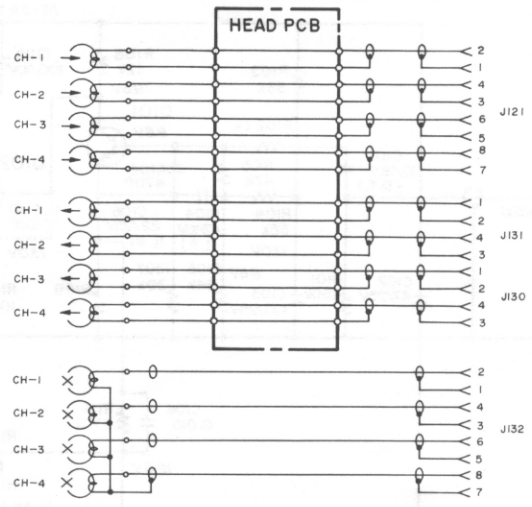
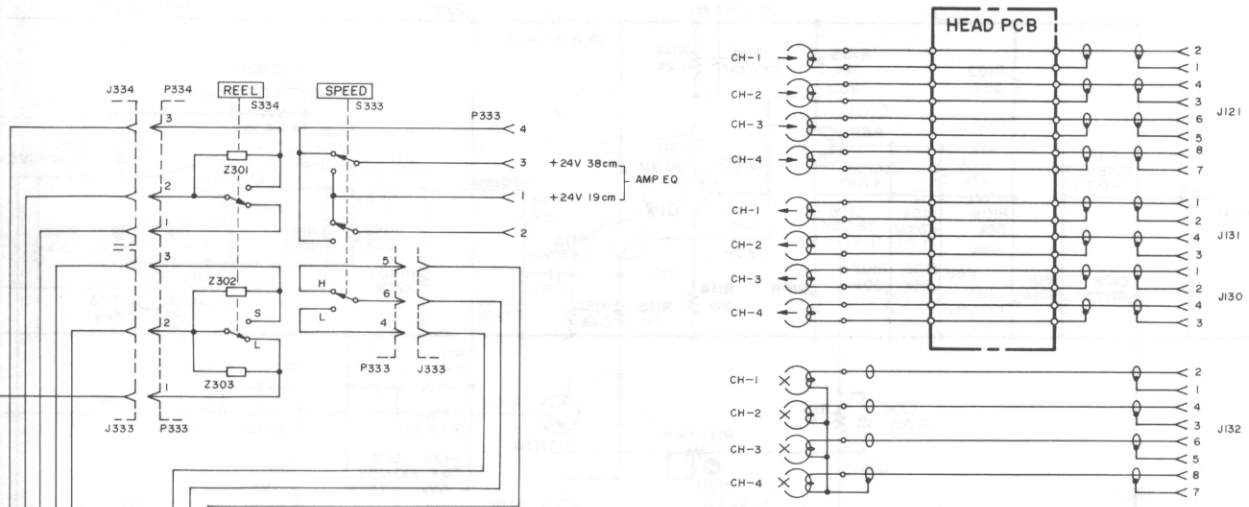

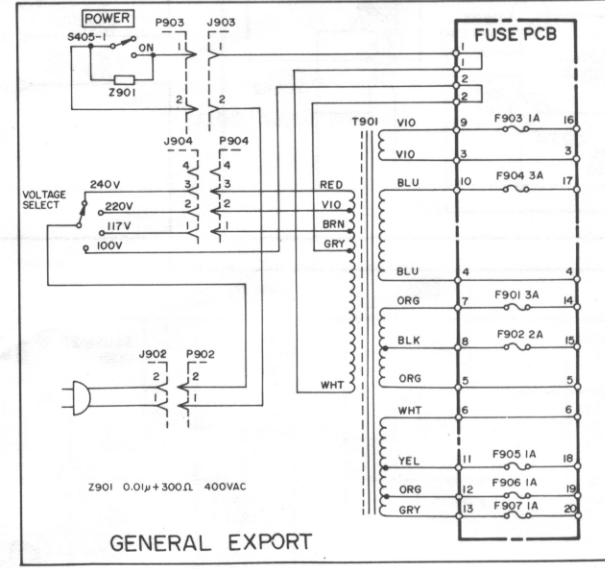
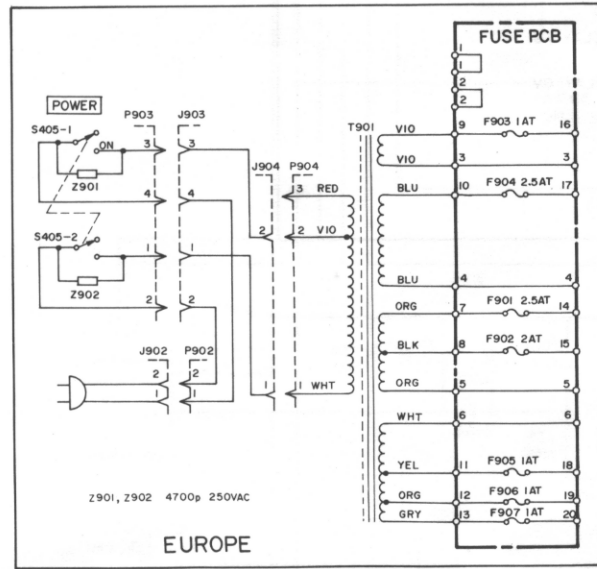
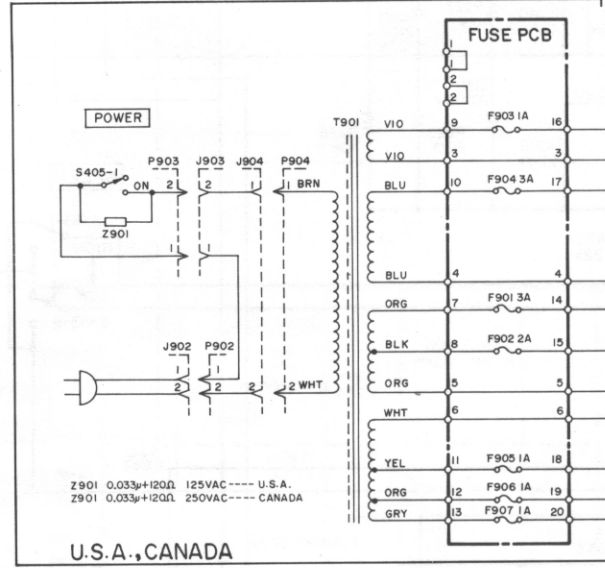
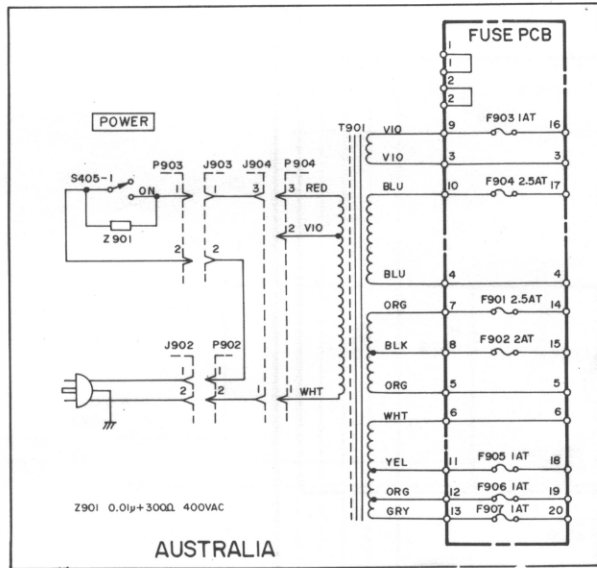

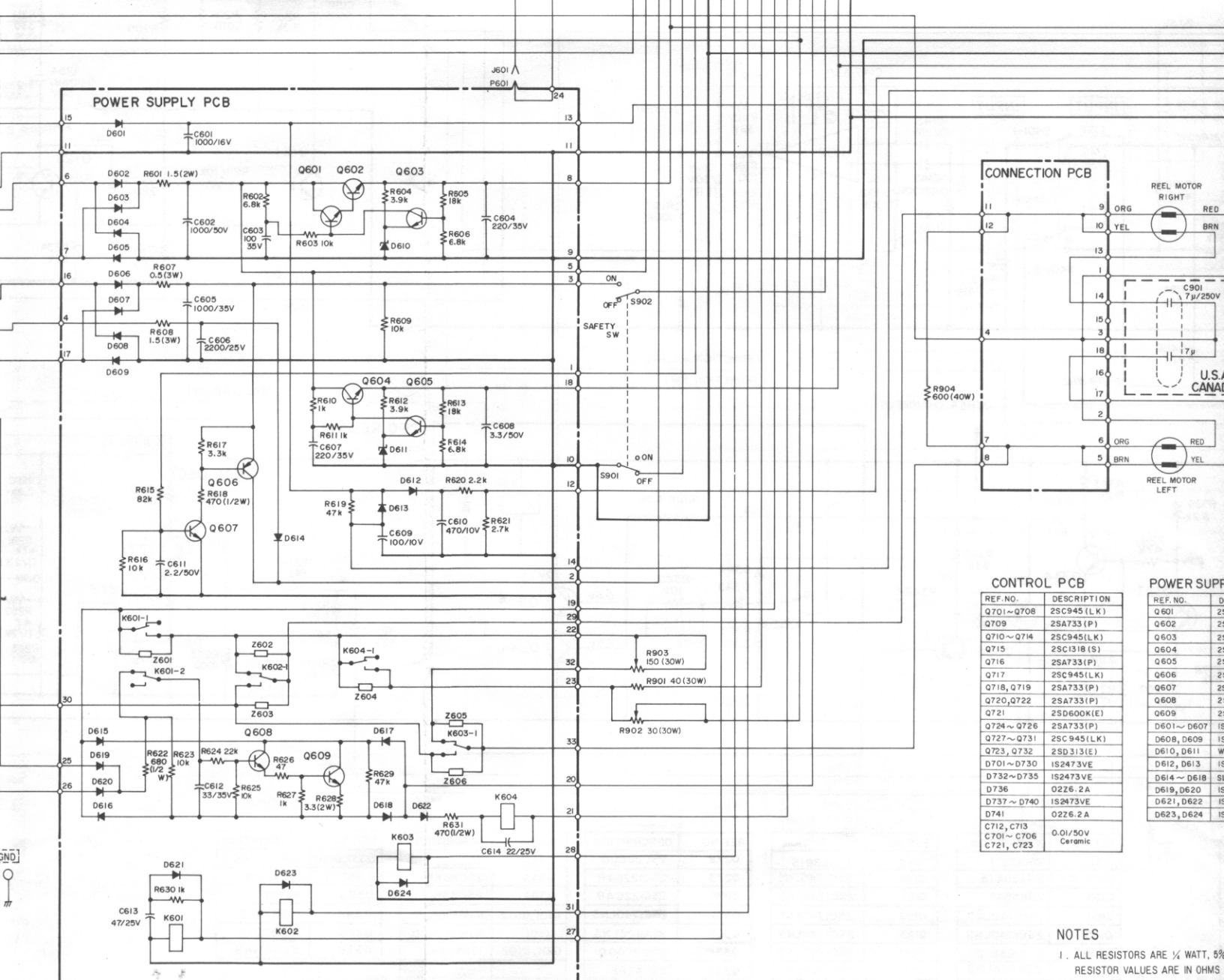

CONTROL PCB		POWER SUPPLY PCB	
REF. NO.	DESCRIPTION	REF. NO.	DESCRIPTION
Q701~Q708	2SC945 (L.K)	Q601	2SC945 (L.K)
Q709	2SA733 (P)	Q602	2SC945 (L.K)
Q710~Q714	2SC945 (L.K)	Q603	2SC945 (L.K)
Q715	2SC1318 (S)	Q604	2SC945 (L.K)
Q716	2SA733 (P)	Q605	2SC945 (L.K)
Q717	2SC945 (L.K)	Q606	2SC945 (L.K)
Q718, Q719	2SA733 (P)	Q607	2SC945 (L.K)
Q720, Q722	2SA733 (P)	Q608	2SC945 (L.K)
Q721	2SD600K(E)	Q609	2SC945 (L.K)
Q724~Q726	2SA733 (P)	D601~D607	1N4001
Q727~Q731	2SC945 (L.K)	D608, D609	1N4001
Q732, Q732	2SD313 (E)	D610, D611	1N4001
D701~D730	1S2473VE	D612, D613	1N4001
D732~D735	1S2473VE	D614~D618	1N4001
D736	0226.2A	D619, D620	1N4001
D737~D740	1S2473VE	D621, D622	1N4001
D741	0226.2A	D623, D624	1N4001
C712, C713	0.01/50V Ceramic		
C701~C706			
C721, C723			

NOTES

- ALL RESISTORS ARE 1/4 WATT, 5% TOLERANCE. RESISTOR VALUES ARE IN OHMS.
- ALL CAPACITOR VALUES ARE IN MICROFARADS.

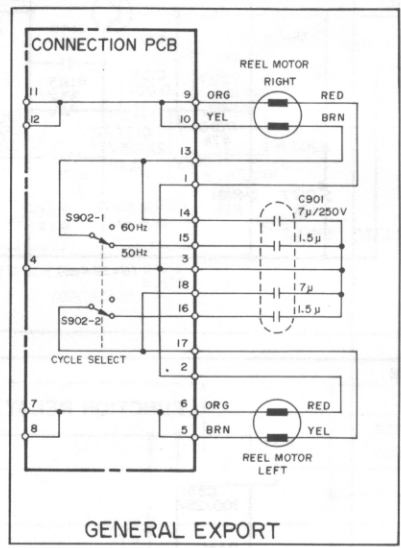
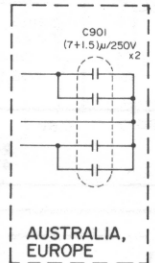
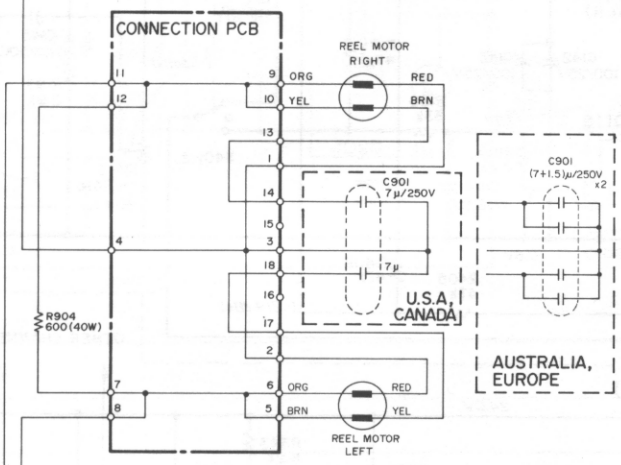

CONTROL PCB

REF. NO.	DESCRIPTION
Q701~Q708	25C945 (L.K)
Q709	2SA733 (P)
Q710~Q714	25C945 (L.K)
Q715	25C1318 (S)
Q716	2SA733 (P)
Q717	25C945 (L.K)
Q718, Q719	2SA733 (P)
Q720, Q722	2SA733 (P)
Q721	25D600K(E)
Q724~Q726	2SA733 (P)
Q727~Q731	25C945 (L.K)
Q723, Q732	25D313 (E)
D701~D730	IS2473VE
D732~D735	IS2473VE
D736	O2Z6.2A
D737~D740	IS2473VE
D741	O2Z6.2A
C712, C713	0.01/50V Ceramic
C701~C706	
C721, C723	

POWER SUPPLY PCB

REF. NO.	DESCRIPTION
Q601	25C1318(S)
Q602	25D313(E)
Q603	25C536(F)
Q604	25D313(E)
Q605	25C536(F)
Q606	25B507(E)
Q607	25C1318(S)
Q608	25D600K(E)
Q609	25D613(E)
D601~D607	ISR34-200
D608, D609	ISR34-200VL
D610, D611	WZ-061
D612, D613	ISR34-200VL
D614~D618	S1B01-06
D619, D620	ISR34-200
D621, D622	ISR34-200VL
D623, D624	ISR34-200

CAPSTAN SERVO PCB

REF. NO.	DESCRIPTION
Q1, Q3	25C828A-R or 25C945-P
Q2	2SA564A-R or 2SA733-P
Q4	25D235-0
TC1	NJM2901N

STOP SENSOR PCB

REF. NO.	DESCRIPTION
Q801, Q802	25C202LNF(R)
Q803	2SA786LNF(R)
Q804, Q805	25C202LNF(R)
D801, D802	IS2473HJ
D803	WZ-090

REF. NO	DESCRIPTION
D901~D903	S1B01-06
C731~C739	0.01/50V
Z601~Z606	0.1/400V
Z301~Z303	0.1/400V

NOTES

- ALL RESISTORS ARE 1/4 WATT, 5%, UNLESS MARKED OTHERWISE. RESISTOR VALUES ARE IN OHMS (k=1,000 OHMS, M=1,000,000 OHMS).
- ALL CAPACITOR VALUES ARE IN MICROFARADS (p=PICOFARADS).

6			
5			
4			
3			
2			
1	06-78	EB-024	
REVISION		DATE	CHANGE NO.

S-225
4-Channel Multitrack Tape Deck
with SIMUL-SYNC
MODEL NO. **A-3440** SHEET NO.
TEAC CORPORATION
A 0101