



For more Hi-Fi manuals and set-up information  
please visit [www.hifiengine.com](http://www.hifiengine.com)

# TC-377

**BEVAN'S SOUND CENTRE**  
 67 THE STRAND  
 LONGTON - STROKE ON TRENT  
 RECORDS - TAPES - CASSETTES



*AEP Model*  
*AUS Model*  
*Canada Model*  
*E Model*  
*USA Model*

## STEREO TAPECORDER

### SPECIFICATIONS

<b>Power Requirements:</b>	AC 120V, 60Hz (Canada, USA) AC 100V, 110V, 117V, 125V, 220V, 240V, 50/60 Hz (E) AC 110V, 127V, 220V, 240V, 50/60Hz (AEP, AUS)	<b>Inputs:</b>	Two MICROPHONE inputs Impedance: low impedance Maximum sensitivity: -72 dB (0.2 mV) Two LINE INPUTS Impedance: 100k $\Omega$ Maximum sensitivity: -22 dB (0.06V) REC/PB connector (AEP, E, AUS) Input impedance: 3.8k $\Omega$
<b>Power Consumption:</b>	38W (Canada, USA) 48W (AEP, E, AUS)	<b>Outputs:</b>	Two LINE OUTPUTS Load impedance: more than 10k $\Omega$ Output level: 0dB (0.78V) with 100k $\Omega$ load REC/PB connector (AEP, E, AUS) Output impedance: 3.3k $\Omega$ HEADPHONE output Load impedance: 8 $\Omega$
<b>Bias Frequency:</b>	Approx. 160kHz	<b>Semiconductors:</b>	23 transistors, 5 diodes
<b>Track System:</b>	Four track two channel stereo and mono	<b>Record Head:</b>	RF140-2902 (70 $\Omega$ /1 kHz)
<b>Reel Size:</b>	7" maximum	<b>Playback Head:</b>	PF140-4202 (1k $\Omega$ /1 kHz)
<b>Tape Speed:</b>	19 cm/s (7 1/2 ips) 9.5 cm/s (3 3/4 ips) 4.8 cm/s (1 7/8 ips)	<b>Erase Head:</b>	EF18-2902A1 (1.6k $\Omega$ /160 kHz)
<b>Frequency Response:</b>	SPECIAL (SONY SLH tape)	<b>Motor:</b>	IC-624H1 (induction motor)
	NAB DIN	<b>Dimensions:</b>	418 (w) x 210 (h) x 392 (d) mm 16 1/2 (w) x 8 3/16 (h) x 15 7/16 (d) inches
19 cm/s (7 1/2 ips):	20~30,000 Hz	30~24,000 Hz	<b>Weight:</b>
19 cm/s (7 1/2 ips):	30~25,000 Hz $\pm$ 3dB	40~16,000 Hz	10.6 kg, 23 lb 6 oz (Canada, USA)
9.5 cm/s (3 3/4 ips):	30~20,000 Hz		11.5 kg, 25 lb 6 oz (AEP, E, AUS)
	NORMAL (Standard tape)		
	NAB DIN		
19 cm/s (7 1/2 ips):	20~25,000 Hz	30~20,000 Hz	
19 cm/s (7 1/2 ips):	30~20,000 Hz $\pm$ 3dB		
9.5 cm/s (3 3/4 ips):	30~17,000 Hz	40~13,000 Hz	
4.8 cm/s (1 7/8 ips):	30~9,000 Hz		
<b>Signal-to-Noise Ratio:</b>	NORMAL SPECIAL		
	52 dB or better	55 dB or better	
<b>Distortion:</b>	1.2%		
<b>Wow and Flutter:</b>	19 cm/s (7 1/2 ips): 0.09% (RMS) weighted 9.5 cm/s (3 3/4 ips): 0.12% (RMS) weighted 4.8 cm/s (1 7/8 ips): 0.17% (RMS) weighted		

2099

**SONY**  
 SERVICE MANUAL

**TABLE OF CONTENTS**

<u>Section</u>	<u>Title</u>	<u>Page</u>
	Specification .....	1
<b>1</b>	<b>OUTLINE</b>	
	1-1. Block Diagram .....	3
	1-2. External Views .....	4
	1-3. Internal Views .....	5
<b>2</b>	<b>DISASSEMBLY</b> .....	6
<b>3</b>	<b>ADJUSTMENTS</b>	
	3-1. Mechanical Adjustments .....	9
	3-2. Electrical Adjustments/Measurements .....	16
	3-3. Power Frequency Adaptation .....	28
<b>4</b>	<b>DIAGRAMS</b>	
	4-1. Level Diagrams .....	29
	4-2. Schematic Diagram .....	31
	4-3. Mounting Diagrams .....	33
	4-3-1. Tape Select Switch Circuit Board .....	33
	4-3-2. Power Supply Circuit Board .....	33
	4-3-3. Bias Osc Circuit Board .....	34
	4-3-4. Record Amp Circuit Board .....	35
	4-3-5. Playback Amp Circuit Board .....	36
<b>5</b>	<b>EXPLODED VIEWS</b>	
	5-1. Cabinet - top view - .....	37
	5-2. Head Deck - top view - .....	38
	5-3. Amplifier Chassis - top view - .....	39
	5-4. Chassis - top view - .....	41
	5-5. Packing .....	43
<b>6</b>	<b>ELECTRICAL PARTS LIST</b> .....	44
<b>7</b>	<b>HARDWARE</b> .....	47
	Hardware Nomenclature .....	47

*When ordering replacement parts, use PART NUMBERS listed in Parts List or shown in EXPLODED VIEW. Parts List reference numbers should not be used.*

# SECTION 1 OUTLINE

## 1-1. BLOCK DIAGRAM

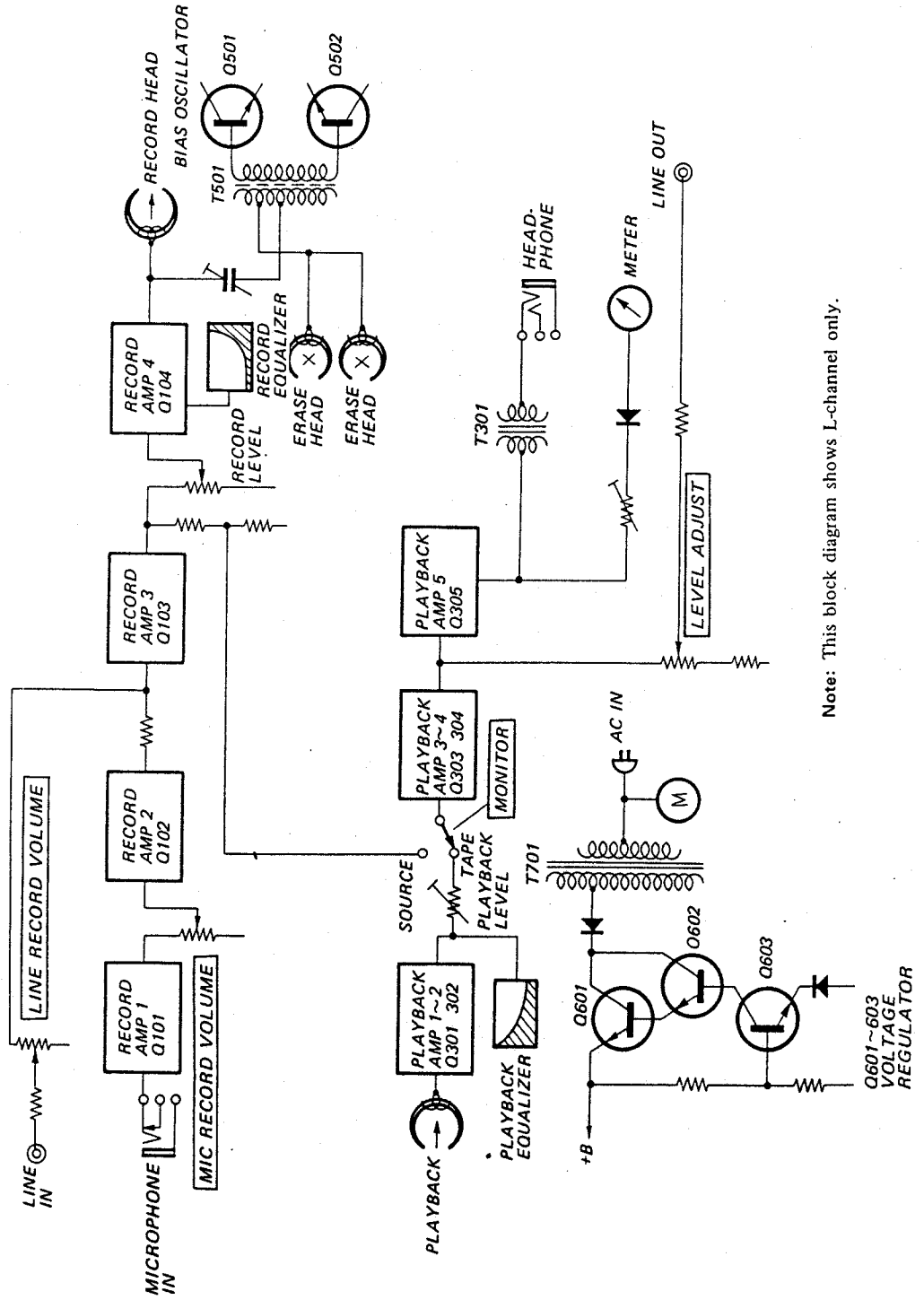

Note: This block diagram shows L-channel only.

# TC-377

## 1-2. MAJOR PARTS LOCATION

Front Panel

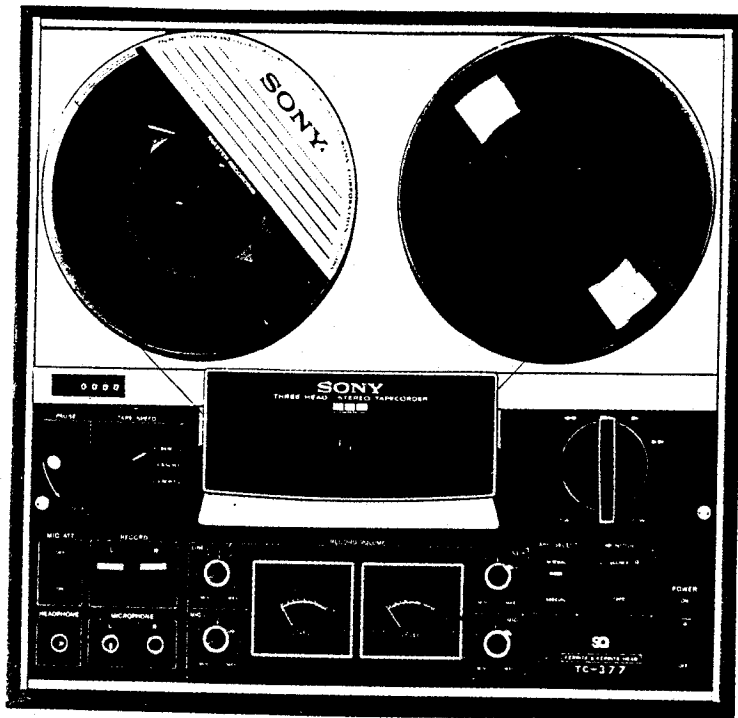

Side Panel

(AEP, AUS, E)

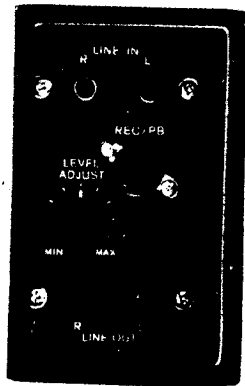

(AEP, AUS)

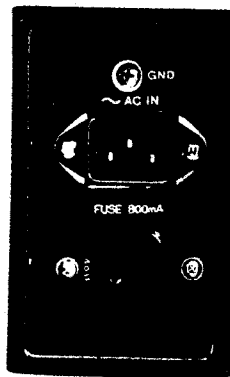

(E)

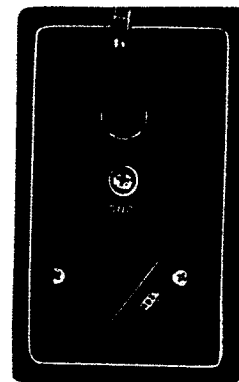

(Canada, USA)

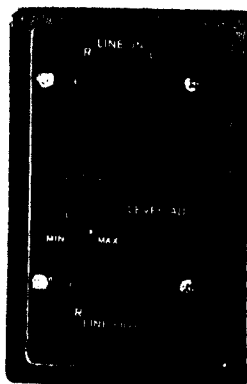

(USA)



(Canada)



1-3. INTERNAL VIEWS

Chassis Front

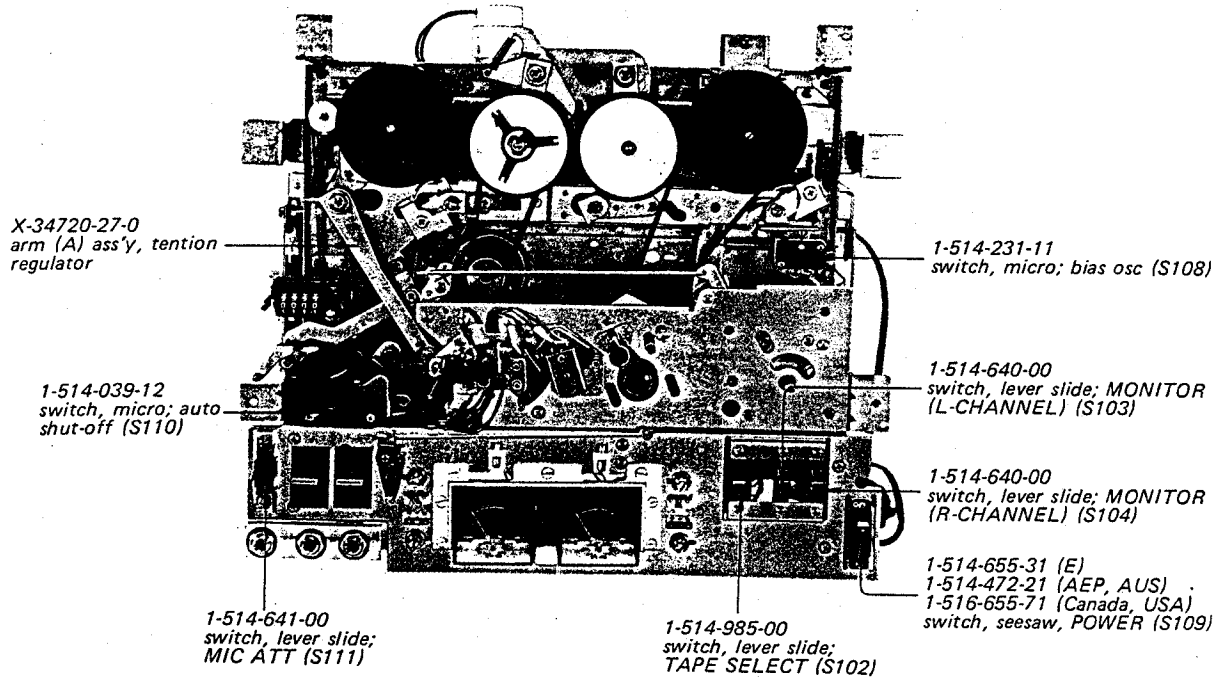

Chassis Rear

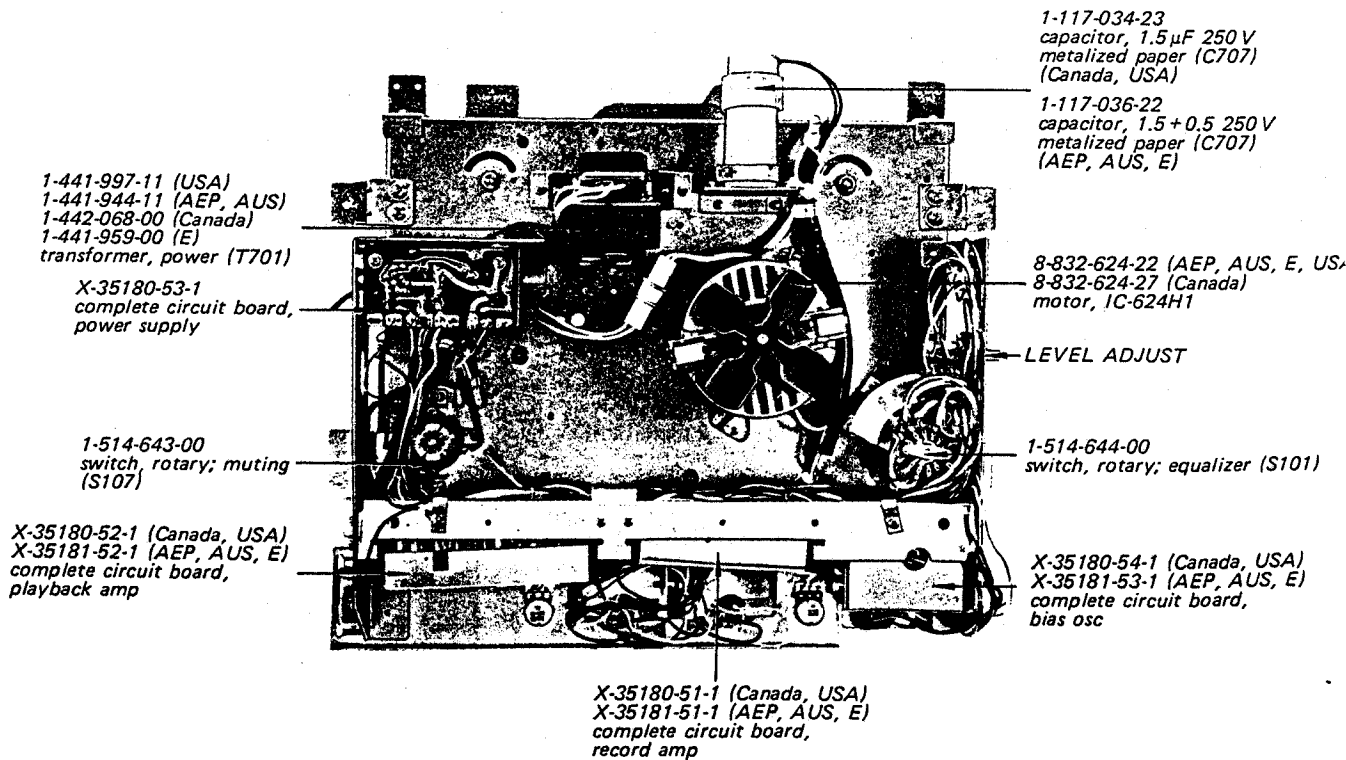

**SECTION 2  
DISASSEMBLY**

**2-1. CABINET REMOVAL**

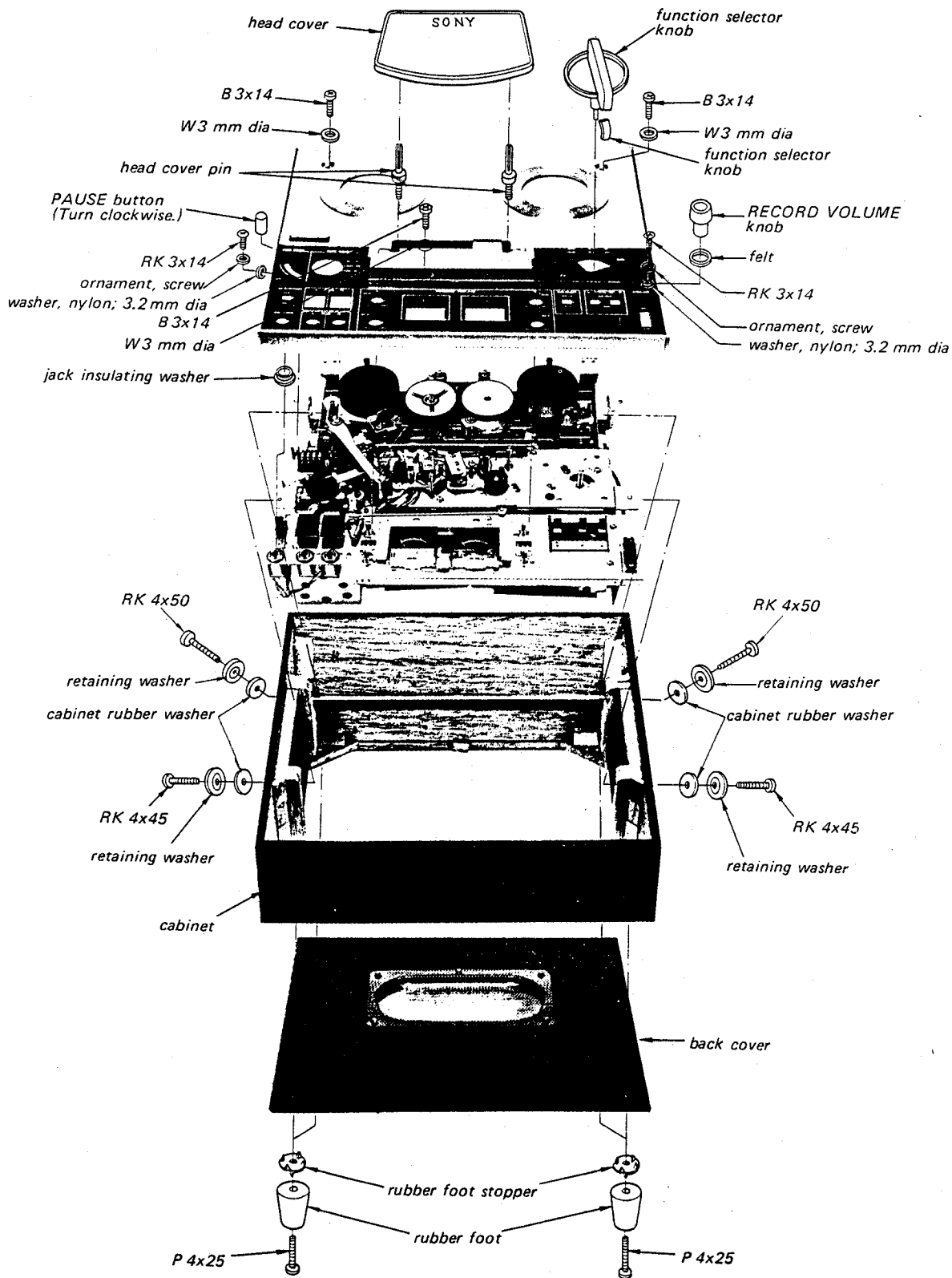

For Service Manuals  
**MAURITRON SERVICES**  
 8 Cherry Tree Road, Chinnor  
 Oxfordshire, OX9 4QY.  
 Tel (01844) 351694  
 Fax (01844) 362654  
 email- mauritron@dial.pipex.com

## 2-2. HEAD DECK REMOVAL

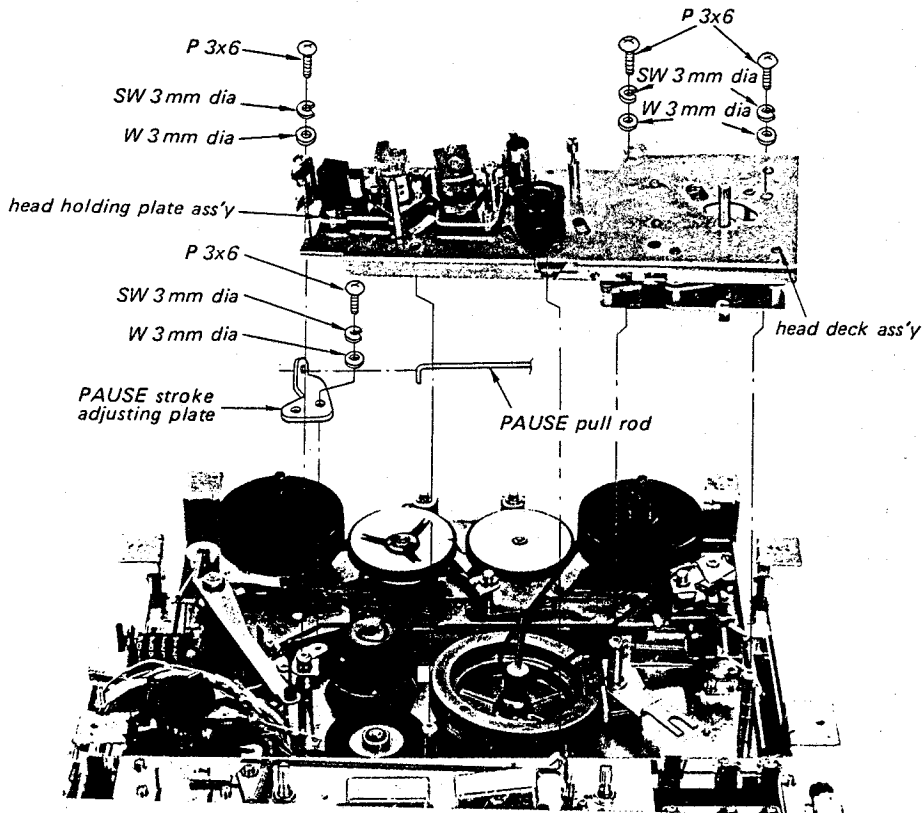

## CAUTION

- (1) Never put the machine upside down on the hard plate with the head cover removed, or the pin of the tape shifter, the shut-off arm pin, the tension arm and others will be bent by the weight of the machine.  
If it is necessary to put the machine upside down, put it on a soft cloth with the head cover attached.
- (2) Do not short-circuit B<sup>+</sup> circuit to ground, or transistor Q601 will be broken.
- (3) When removing PAUSE button, turn it clockwise.
- (4) Turn on the power switch after being certain that the motor fan does not touch anything.



**MEMO**

Series of horizontal dotted lines for writing.

## SECTION 3 ADJUSTMENTS

### 3-1. MECHANICAL ADJUSTMENTS

**Precaution:**

Do not use magnetized screwdriver for adjustments.

After adjustments, apply locking paint to the adjusted parts.

#### Tension Regulator Adjustment

**STOP mode**

- Loosen the adjusting screw and adjust so that the clearance shown is 8 mm ( $5/16$ "") after having been turned reel table counterclockwise by hand.

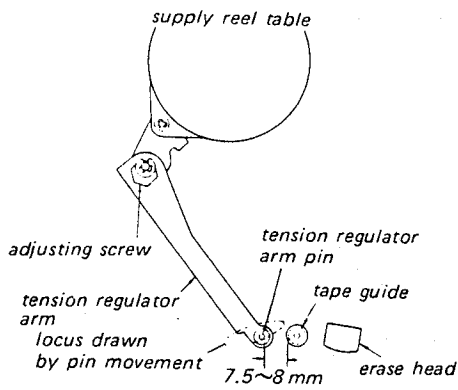

- Tape should be in contact with tension regulator pin uniformly at beginning and end portion of it.

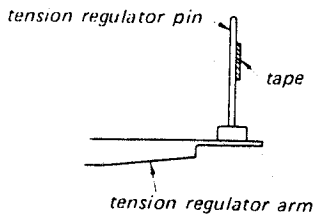

#### Tension Regulator Back-tension Adjustment

**FWD and FF modes**

This adjustment should be done after Tension Regulator Adjustment.

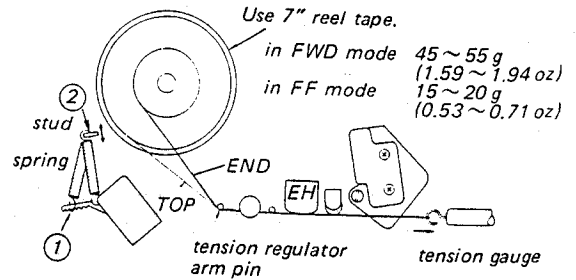

- Adjust by changing the spring hook position.
- If necessary, adjust by bending the stud or perform the tension regulator adjustment again.

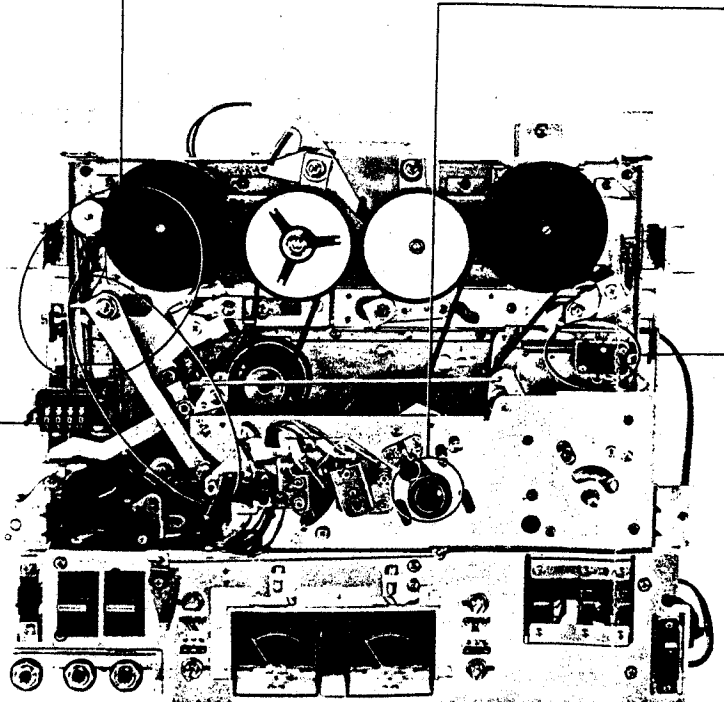

SECTION 3  
ADJUSTMENTS

ENTS  
driver for adjust-  
cking paint to the

and adjust so that  
3 mm (5/16") after  
e counterclockwise

on regulator  
pin  
tape guide  
m erase head

with tension regu-  
ginning and end

tape  
arm

Tension Regulator Back-tension Adjustment

FWD and FF modes

This adjustment should be done after Tension Regulator Adjustment.

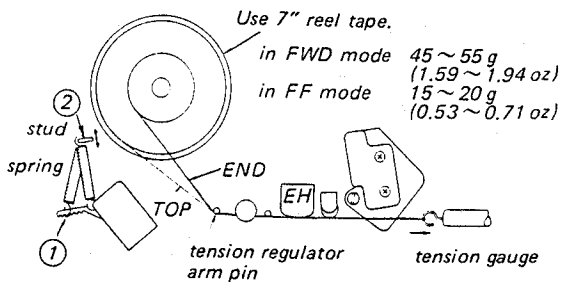

- ① Adjust by changing the spring hook position.
- ② If necessary, adjust by bending the stud or perform the tension regulator adjustment again.

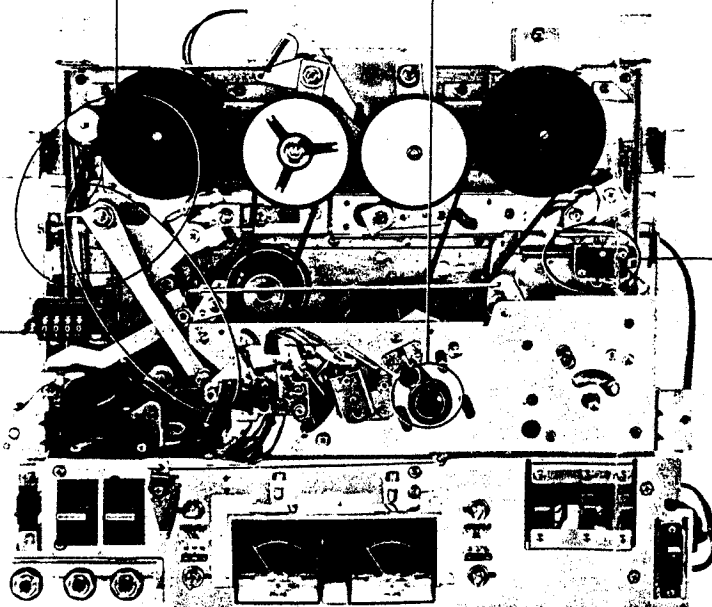

Pinch Roller Pressure Check

STOP mode

1. Remove head deck ass'y. (See "HEAD REMOVAL" on page 7)
2. Put dummy capstan into capstan be sure that the clearance between (A) and (B) is approx. 0.5 mm (1/64")

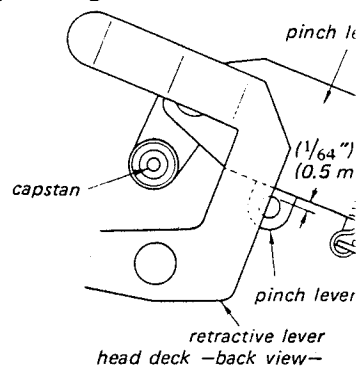

3. Be sure that the tension gauge indicates 1,000 g (1 lb 12 oz ~ 2 lb 3 oz) when roller is detached from capstan in FWD mode

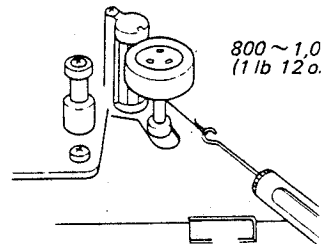

Bias Switch Position Adjustment

Loosen two screws and adjust by position of the switch.

Switch should be turned ON in FWD mode and with function selector knob changed from FWD to STOP, record levers are retracted and the switch turns OFF.

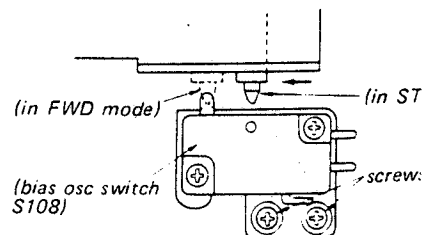

### 2. Tape Curl Adjustment

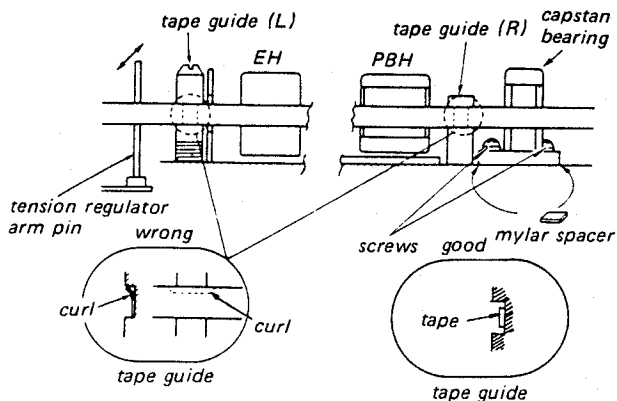

**Procedure:**

1. Thread SONY tape super 200 (thin tape) and place unit in playback mode at 4.8 cm/s (1 7/8 ips) tape speed.
2. Be sure that the tape comes in contact with two tape guides exactly as shown.
  - a) If tape is curled at tape guide (L), adjust by bending tension regulator arm pin with fingers.
  - b) If tape is curled at tape guide (R), loosen two capstan bearing holding screws and adjust by adding or removing the mylar spacer.

**Note:** After adding or removing the mylar spacer (0.1 mm thick), perform playback head zenith adjusting screw. (See "Record and Playback Head Preadjustment" on page 17.)

### 3. Playback Head Angle Adjustment

**Control/Switch Setting:**

- TAPE SELECT switch: NORMAL
- TAPE SPEED selector: 7 1/2 ips (19 cm/s)
- MONITOR switch: TAPE

**Procedure:**

1. Mode: playback

J-19-F1  
(1st tone 10kHz)

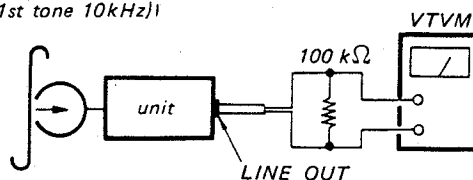

2. Adjust angle-adjusting screws for maximum VTVM reading.
3. Apply back-tension by holding lightly the supply reel table, reproducing the alignment tape, and then adjust the angle of the head by loosening two angle-adjusting screws so that VTVM reading on both L-CH and R-CH does not rise.

**Note:** Unless playback head is installed at correct angle, VTVM reading will rise.

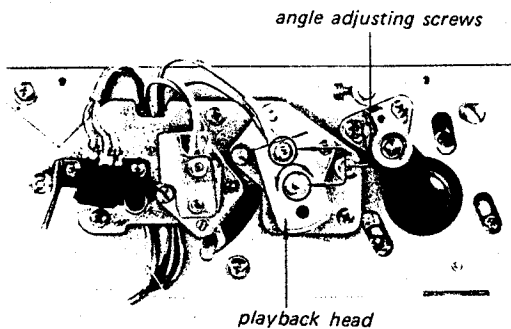

**4. Playback Head Azimuth Adjustment**

**Control/Switch Setting:**

- TAPE SELECT switch: NORMAL
- TAPE SPEED selector: 7½ ips (19 cm/s)
- MONITOR switch: TAPE

**Procedure:**

1. Be sure that playback head is fixed sufficiently to head deck with holding screw as shown below and tape path adjustment has been made.
2. Mode: playback

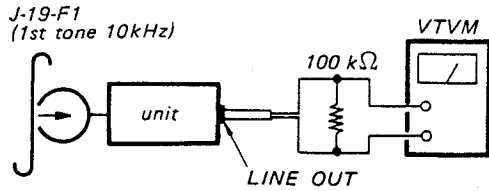

3. Adjust azimuth adjusting screw for maximum VTVM reading.

**Note:** If azimuth angles of L-CH and R-CH are not the same, set the screw midway between two screw positions.

**Adjustment Location:**

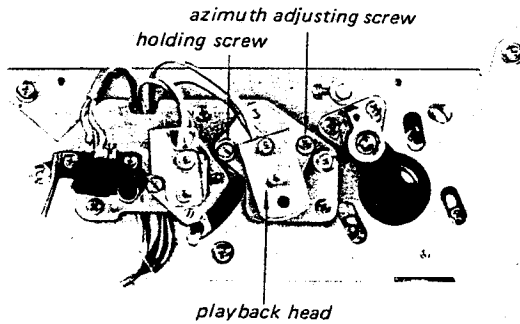

**5. Playback Head Phase Check**

**Control/Switch Setting:**

- TAPE SELECT switch: NORMAL
- TAPE SPEED selector: 7½ ips (19 cm/s)
- MONITOR switch: TAPE

**Procedure:**

1. Mode: playback

J-19-F1  
(1st tone 10kHz)

J-19-F1  
(3rd tone 400Hz)

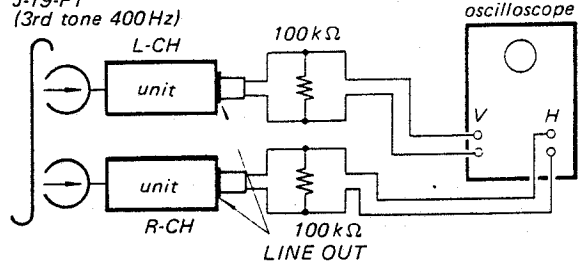

- 2.

Adjust	On the oscilloscope			
azimuth adjusting screw				
(400 Hz)	good	wrong		
(10 kHz)	good		wrong	

**Note:** If necessary, finely adjust the playback head azimuth adjusting screw.

**6. Playback Output Level Adjustment and Level Meter Calibration**

**Control/Switch Setting:**

TAPE SELECT switch: NORMAL  
 TAPE SPEED selector: 7½ ips (19 cm/s)  
 MONITOR switch: TAPE

**Procedure:**

1. Mode: playback

J-19-F1  
 (2nd tone, 400 Hz)

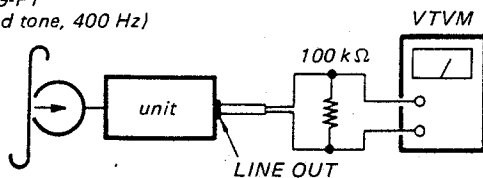

2. Adjust R316, R416 for 0 dB (0.78V) VTVM reading.
3. Adjust R327, R427 for 0 reading on RECORD LEVEL meters.
4. Change TAPE SELECT switch to SPECIAL and be sure that VTVM reading is -2 dB ~ -3 dB (0.62~0.55V).

**Adjustment Location:**

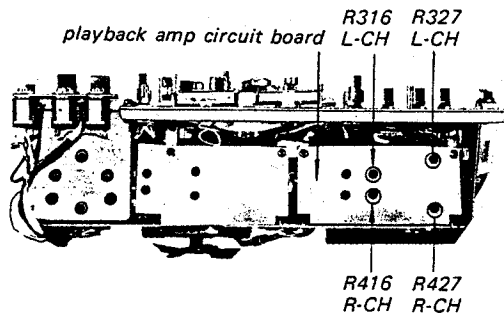

**7. Playback Equalizer Adjustment**

**Control/Switch Setting:**

TAPE SELECT switch: NORMAL  
 TAPE SPEED selector: 7½ ips (19 cm/s)  
 MONITOR switch: TAPE

**Procedure:**

1. Mode: playback

J-19-F1  
 3rd tone, 400 Hz

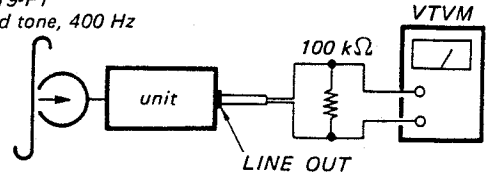

Memorize VTVM reading.

2. Mode: playback

J-19-F1  
 4th tone, 10 kHz

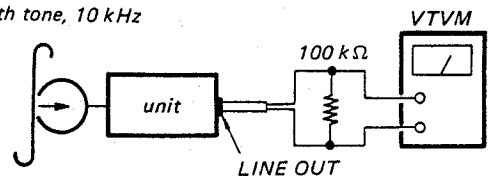

Adjust R313, 413 to obtain the same VTVM reading as in step 1.

3. Playback the following tones and make sure that each tone output level deviation against 3rd tone is as follows.

	Tone	4th	5th	6th	7th
J-19-F1	Frequency (Hz)	10k	7k	80	40
Level Deviation from 3rd tone (400Hz)	L-CH	0±2dB	0±2dB	2±2dB	4±2dB
	R-CH			2.5±2dB	4.5±2dB

**Adjustment Location:**

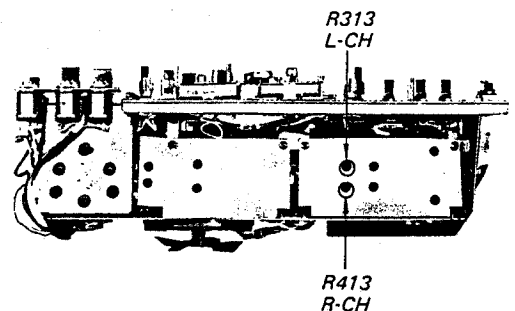

**8. Playback S/N Ratio Check**

**Control/Switch Setting:**

TAPE SELECT switch: NORMAL  
 TAPE SPEED selector: 7½ ips (19 cm/s)  
 MONITOR switch: TAPE

**Procedure:**

1. Mode: playback

J-19-F1  
 2nd tone 400Hz

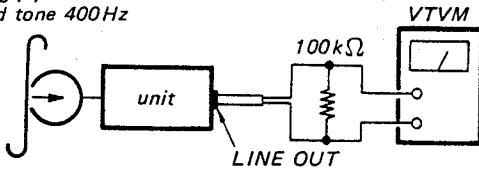

2. VTVM reading should be 0 dB (0.78V). If not, make playback output level adjustment again.
3. With no tape threaded, keep on pushing shut-off lever with finger.

Mode: playback.

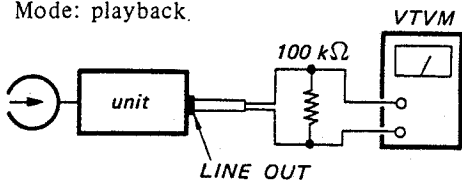

4. Be sure that VTVM reading is less than -48 dB (3 mV).

**Note:** S/N ratio may change by reversing the sense of motor leads.

**9. Record Head Azimuth and Track Position Adjustment**

**Control/Switch Setting:**

TAPE SELECT switch: NORMAL  
 TAPE SPEED selector: 7½ ips (19 cm/s)  
 MONITOR switch: TAPE  
 LINE RECORD  
 VOLUME control: See page 16

**Procedure:**

1. Mode: record

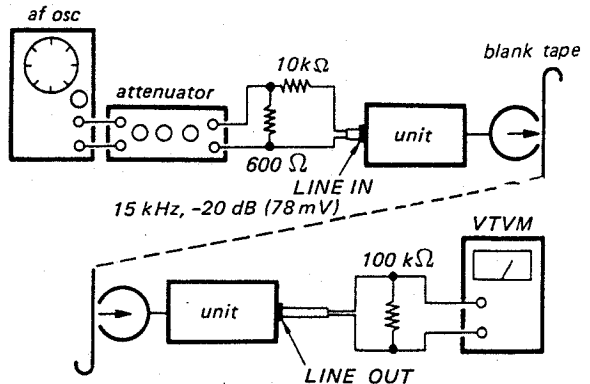

2. Adjust azimuth adjusting screw for maximum VTVM reading.

**Note:** If the maximum value of L-CH and R-CH outputs can not be obtained at the same angle, adjust the screw midway between two screw positions. (That value should not be fallen more than 1 dB from the maximum value.)

3. Supply a 1 kHz signal of -10 dB (0.24 V) into R-CH LINE IN jack and record the signal on the blank tape.
4. Adjust the height adjusting screw for maximum VTVM reading and memorize the angle of turns of the screw.
5. Turn the zenith adjusting screw by the same angle of turns obtained in preceding step 4.
6. After the adjustment, check tape path adjustment on page 17 again.

**Adjustment Location:**

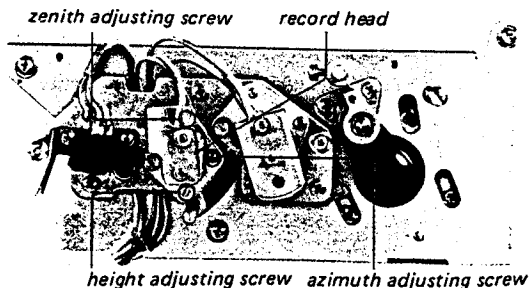

**10. Record Head Phase Check**

**Control/Switch Setting:**

- TAPE SELECT switch: NORMAL
- TAPE SPEED selector: 7½ ips (19 cm/s)
- MONITOR switch: TAPE
- LINE RECORD
- VOLUME control: See page 16

**Procedure:**

1. Make the playback head phase check on page 19 first.
2. Mode: record

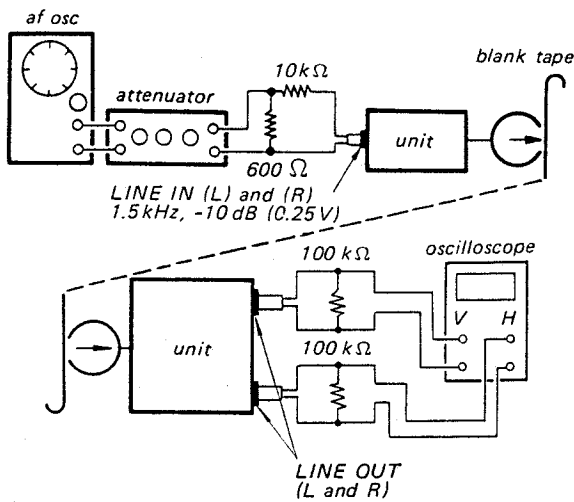

3.

Adjust	On the oscilloscope
azimuth adjusting screw	

**Note:** If necessary, finely adjust record head azimuth adjusting screw.

**11. Trap Coil Adjustment**

**Control/Switch Setting:**

- TAPE SELECT switch: NORMAL
- TAPE SPEED selector: 7½ ips (19 cm/s)
- MIC RECORD
- VOLUME control: MIN (fully counterclockwise)

**Procedure:**

1. Connect a VTVM across the check point and ground as shown.

(RECORD AMP CIRCUIT BOARD)

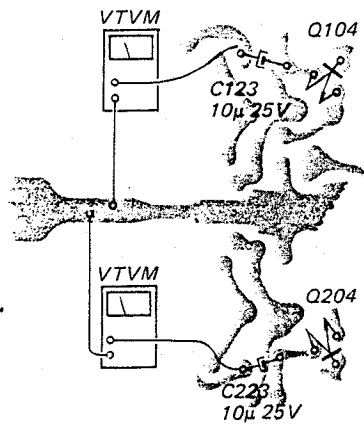

2. Place unit in record mode without tape.
3. Adjust L104, L204 to obtain the minimum VTVM reading (less than -7 dB, 0.35V).

**Adjustment Location:**

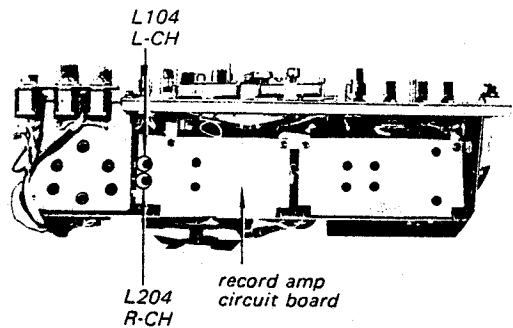



**12. Record Bias Adjustment**

**Control/Switch Setting:**

- TAPE SELECT switch: NORMAL
- TAPE SPEED selector: 7½ ips (19 cm/s)
- MONITOR switch: TAPE
- LINE RECORD
- VOLUME control: See page 16

**Procedure:**

1. Be sure that trap coil adjustment has been made.
2. Mode: record

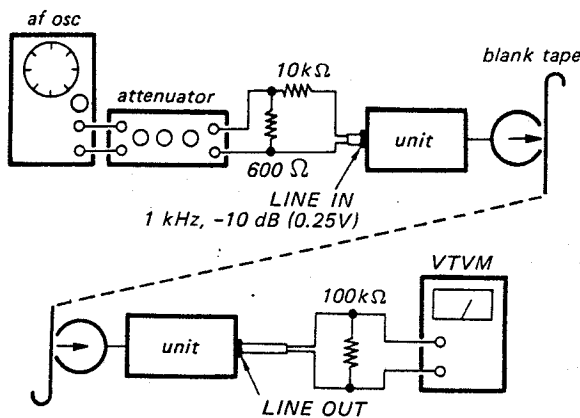

3. Turn the bias adjusting trimmer capacitors C503, C504 counterclockwise for maximum VTVM reading and then turn the capacitor counterclockwise so that VTVM reading drops 0.5 dB from the maximum value.
4. After the adjustment, be sure that voltage across record head is approximately 14V on VTVM and it decreases, as TAPE SPEED selector is changed to 3¼ ips (9.5 cm/s) and then 1⅞ ips (4.8 cm/s).

**Adjustment Location:**

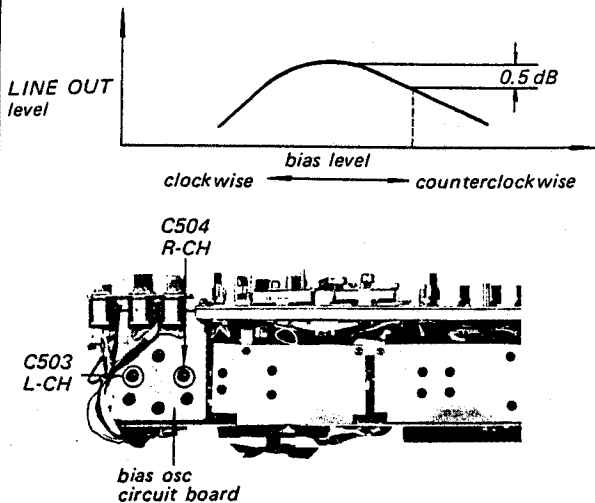

**13. Record Level Adjustment**

**Control/Switch Setting:**

- TAPE SELECT switch: NORMAL
- TAPE SPEED selector: 7½ ips (19 cm/s)
- MONITOR switch: TAPE
- LINE RECORD
- VOLUME control: See page 16

**Procedure:**

1. Mode: record

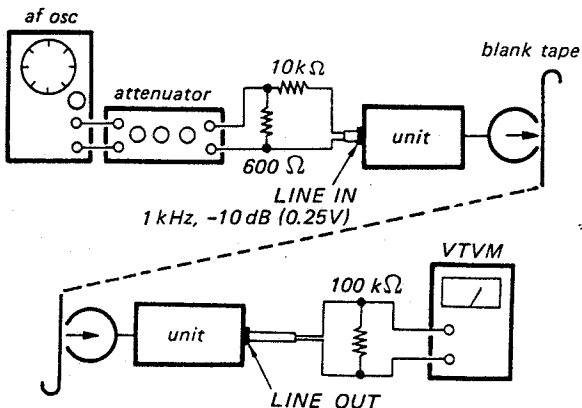

2. Adjust R128, R228 for 0 dB (0.78V) VTVM reading.
3. Be sure that VTVM reading is 0 dB (0.78V) when changing MONITOR switch from TAPE to SOURCE position and the pointer of RECORD LEVEL meter stays at "0".
4. When TAPE SELECT switch is changed to SPECIAL with MONITOR switch to SOURCE, VTVM reading should decrease approx. 1.5 dB.

**Adjustment Location:**

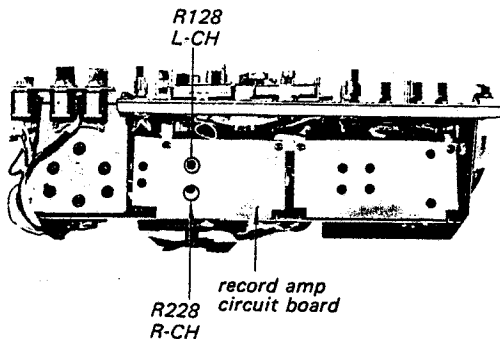

**14. Dummy Coil Adjustment**

**Control/Switch Setting:**

- TAPE SELECT switch: NORMAL
- TAPE SPEED selector: 7½ ips (19 cm/s)
- MONITOR switch: TAPE
- LINE RECORD
- VOLUME control: See page 16

**Procedure:**

1. Mode: stereo record

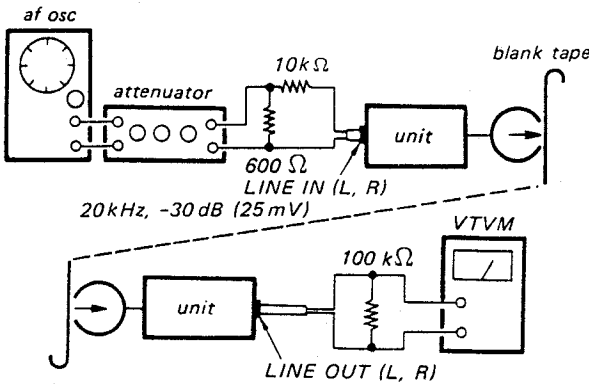

2. Memorize VTVM readings.
3. Set L-channel (R-channel) only in record mode.
4. Adjust L502 (L501) with non-magnetic screwdriver, taking care not to break the core, so that VTVM reading is the same as that obtained in step 2.

**Adjustment Location:**

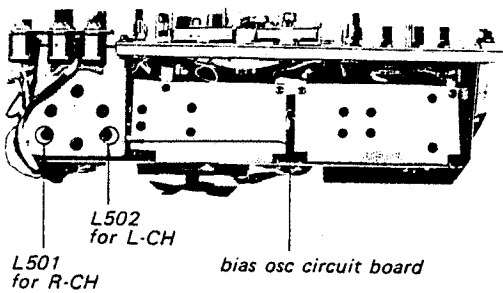

**15. Erase Ratio Measurement**

**Control/Switch Setting:**

- TAPE SELECT switch: NORMAL
- TAPE SPEED selector: 7½ ips (19 cm/s)
- MONITOR switch: TAPE
- LINE RECORD
- VOLUME control: See page 16

**Procedure:**

1. Mode: stereo record

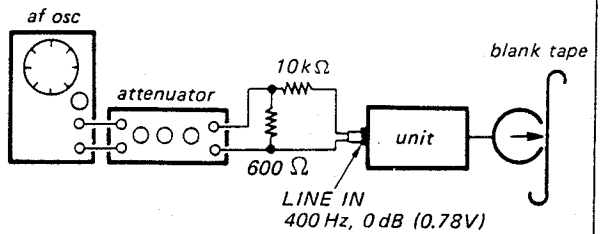

2. Rewind half of the recorded part.
3. Mode: stereo record (erase)

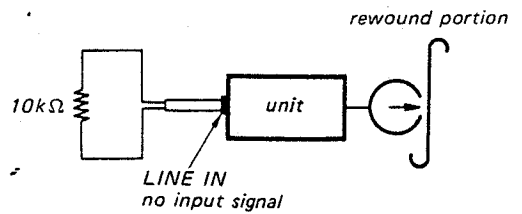

4. Mode: playback

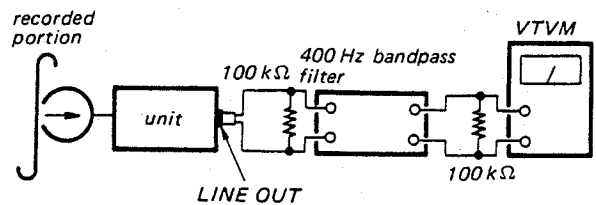

**Specification:**

Recorded Signal	VTVM Reading
1 kHz	level difference: greater than 65 dB
erased portion	

**16. Overall Frequency Response Measurement**

**Control/Switch Setting:**

- TAPE SELECT switch: NORMAL and SPECIAL
- TAPE SPEED selector: 7½ ips (19 cm/s)  
3¾ ips (9.5 cm/s)  
and 17⁄8 ips (4.8 cm/s)
- MONITOR switch: TAPE
- LINE RECORD
- VOLUME control: See page 16

**Procedure:**

1. Mode: record

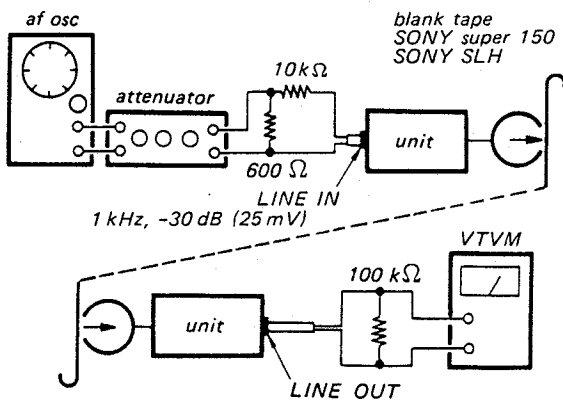

2. Level Deviation from 1 kHz signal.  
(for both SPECIAL and NORMAL)

Frequency Tape speed	50 Hz	100 Hz	5 kHz	7 kHz	12.5 kHz	20 kHz
19 cm/s	±3 dB	±3	±3	±3	±3	+3 -4
9.5 cm/s	+3 -6	±3	±3	±3	+3 -4	
4.8 cm/s	+4 -5	+5 -1	+1 -6			

**Note:** When recording signal on SONY tape "super 150", set TAPE SELECT switch to NORMAL and on SONY SLH tape, to SPECIAL.

**17. Overall S/N Ratio Measurement**

**Control/Switch Setting:**

- TAPE SELECT switch: NORMAL and SPECIAL
- TAPE SPEED selector: 7½ ips (19 cm/s)
- MONITOR switch: TAPE
- MIC RECORD
- VOLUME control: See page 16

**Procedure:**

1. Mode: record

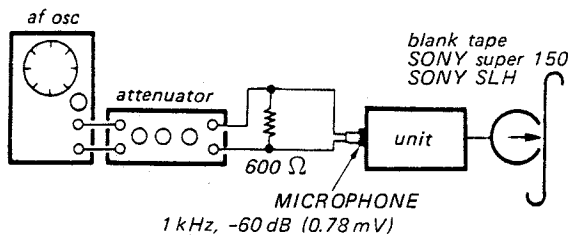

2. Mode: record

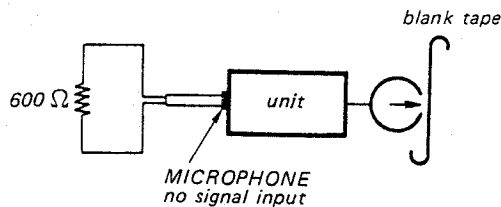

3. Mode: playback

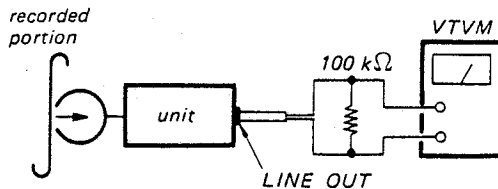

**Specification:**

Recorded Signal	VTVM Reading	
	NORMAL	SPECIAL
1 kHz	level difference: greater than 45 dB	level difference: greater than 47 dB
no signal		

**Note:** When recording signal on SONY tape "super 150", set TAPE SELECT switch to NORMAL and on SONY SLH tape, to SPECIAL.

**For Service Manuals**  
**MAURITRON SERVICES**  
 8 Cherry Tree Road, Chinnor  
 Oxfordshire, OX2 4QY.  
 Tel (01844) 351694  
 Fax (01844) 352554  
 email:- mauritron@dial.pipex.com

**18. Overall Distortion Measurement**

**Control/Switch Setting:**

- TAPE SELECT switch: NORMAL
- TAPE SPEED selector: 7 1/2 ips (19 cm/s)
- MONITOR switch: TAPE
- LINE RECORD
- VOLUME control: See page 16

**Procedure:**

1. Mode: record

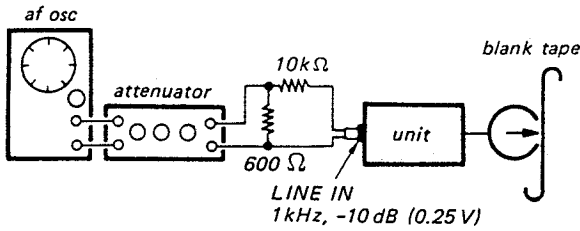

2. Mode: playback

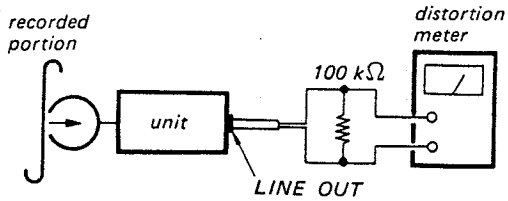

Specification: less than 1.5%

**19. Cross-talk Measurement (between channels)**

**Control/Switch Setting:**

- TAPE SELECT switch: NORMAL
- TAPE SPEED selector: 7 1/2 ips (19 cm/s)
- MONITOR switch: TAPE
- LINE RECORD
- VOLUME control: See page 16

**Procedure:**

1. Mode: stereo record

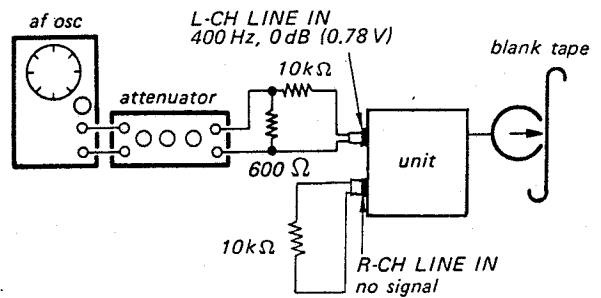

2. Mode: playback

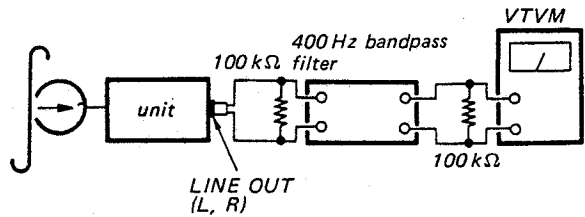

Specification:

Playback	VTVM Reading
L-CH (400 Hz)	level difference: greater than 48 dB
R-CH (no signal)	

**20. Cross-Talk Measurement  
(between tracks)**

**Control/Switch Setting:**

- TAPE SELECT switch: NORMAL
- TAPE SPEED selector: 7 1/2 ips (19 cm/s)
- MONITOR switch: TAPE
- LINE RECORD
- VOLUME control: See page 16

**Procedure:**

1. Mode: stereo record

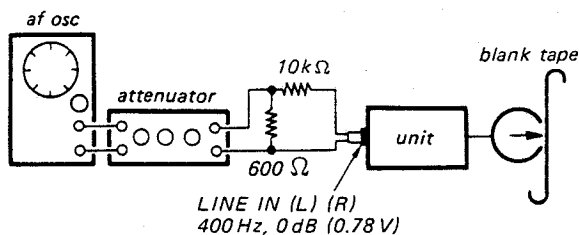

2. Turn the reels over.
3. Mode: playback

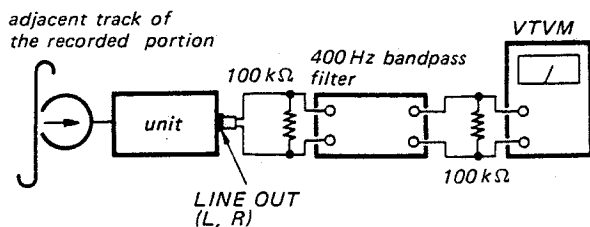

**Specification:**

Playback	VTVM reading
400 Hz	level difference: greater than 65 dB
adjacent track of the recorded portion	

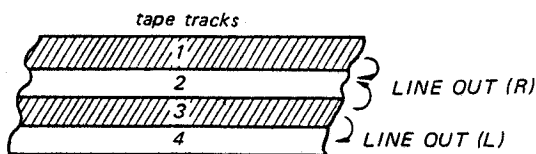

**21. Minimum Input Level Check**

**Control/Switch Setting:**

MONITOR switch: SOURCE

**Procedure:**

**A. MICROPHONE Jack Level Check**

1. Set LINE RECORD VOLUME to MIN and MIC RECORD VOLUME to MAX position.
2. Supply 1 kHz signal into MICROPHONE jack and adjust attenuator to obtain 0 dB (0.78 V) VTVM reading.
3. Be sure that MICROPHONE jack level is less than -72 dB (0.2 mV).

**B. LINE IN Jack Level Check**

1. Set MIC RECORD VOLUME to MIN and LINE RECORD VOLUME to MAX position.
2. Supply 1 kHz signal into LINE IN jack and adjust attenuator to obtain 0 dB (0.78 V) VTVM reading.
3. Be sure that LINE IN jack level is less than -22 dB (61.5 mV).

**Mode: record**

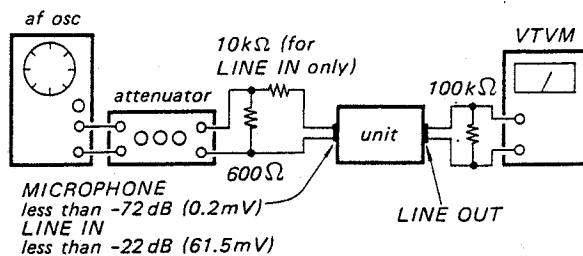

**4. Playback Head Azimuth Adjustment**

**Control/Switch Setting:**

- TAPE SELECT switch: NORMAL
- TAPE SPEED selector: 7½ ips (19 cm/s)
- MONITOR switch: TAPE

**Procedure:**

1. Be sure that playback head is fixed sufficiently to head deck with holding screw as shown below and tape path adjustment has been made.

2. Mode: playback

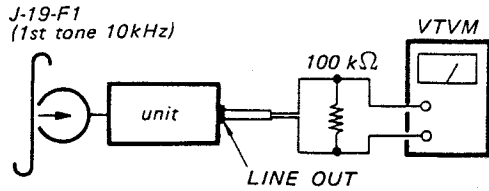

3. Adjust azimuth adjusting screw for maximum VTVM reading.

**Note:** If azimuth angles of L-CH and R-CH are not the same, set the screw midway between two screw positions.

**Adjustment Location:**

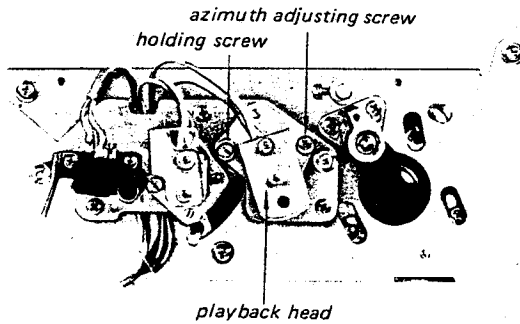

**5. Playback Head Phase Check**

**Control/Switch Setting:**

- TAPE SELECT switch: NORMAL
- TAPE SPEED selector: 7½ ips (19 cm/s)
- MONITOR switch: TAPE

**Procedure:**

1. Mode: playback

J-19-F1  
(1st tone 10kHz)

J-19-F1  
(3rd tone 400Hz)

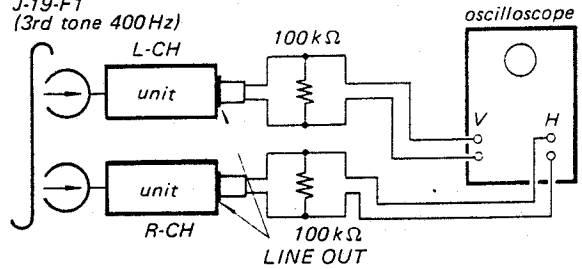

- 2.

Adjust	On the oscilloscope			
azimuth adjusting screw				
(400 Hz)	good	wrong		
(10 kHz)	good		wrong	

**Note:** If necessary, finely adjust the playback head azimuth adjusting screw.

**6. Playback Output Level Adjustment and Level Meter Calibration**

**Control/Switch Setting:**

TAPE SELECT switch: NORMAL  
 TAPE SPEED selector: 7½ ips (19 cm/s)  
 MONITOR switch: TAPE

**Procedure:**

1. Mode: playback

J-19-F1  
 (2nd tone, 400 Hz)

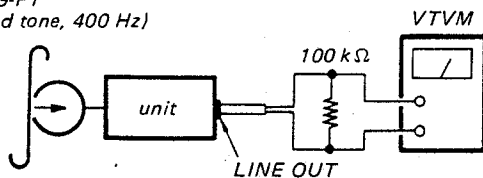

2. Adjust R316, R416 for 0 dB (0.78V) VTVM reading.
3. Adjust R327, R427 for 0 reading on RECORD LEVEL meters.
4. Change TAPE SELECT switch to SPECIAL and be sure that VTVM reading is -2 dB ~ -3 dB (0.62~0.55V).

**Adjustment Location:**

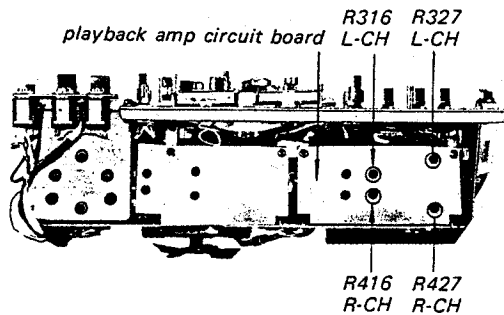

**7. Playback Equalizer Adjustment**

**Control/Switch Setting:**

TAPE SELECT switch: NORMAL  
 TAPE SPEED selector: 7½ ips (19 cm/s)  
 MONITOR switch: TAPE

**Procedure:**

1. Mode: playback

J-19-F1  
 3rd tone, 400 Hz

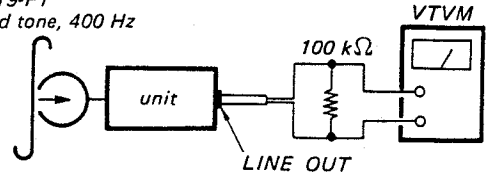

Memorize VTVM reading.

2. Mode: playback

J-19-F1  
 4th tone, 10 kHz

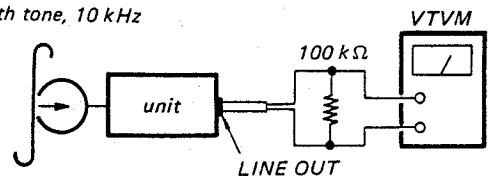

Adjust R313, 413 to obtain the same VTVM reading as in step 1.

3. Playback the following tones and make sure that each tone output level deviation against 3rd tone is as follows.

	Tone	4th	5th	6th	7th
J-19-F1	Frequency (Hz)	10k	7k	80	40
Level Deviation from 3rd tone (400Hz)	L-CH	0±2dB	0±2dB	2±2dB	4±2dB
	R-CH			2.5±2dB	4.5±2dB

**Adjustment Location:**

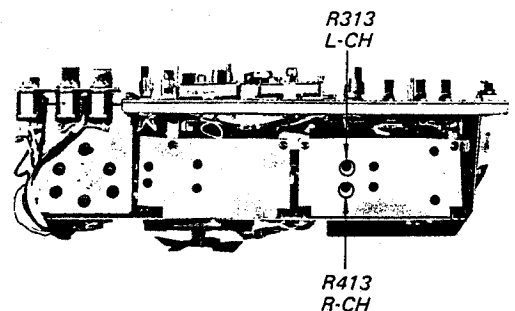

**8. Playback S/N Ratio Check**

**Control/Switch Setting:**

TAPE SELECT switch: NORMAL  
 TAPE SPEED selector: 7½ ips (19 cm/s)  
 MONITOR switch: TAPE

**Procedure:**

1. Mode: playback

J-19-F1  
 2nd tone 400Hz

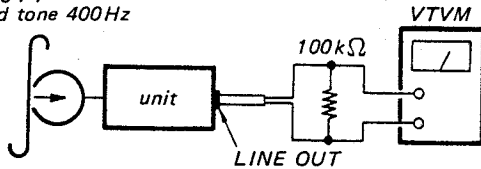

2. VTVM reading should be 0 dB (0.78V). If not, make playback output level adjustment again.
3. With no tape threaded, keep on pushing shut-off lever with finger.

Mode: playback.

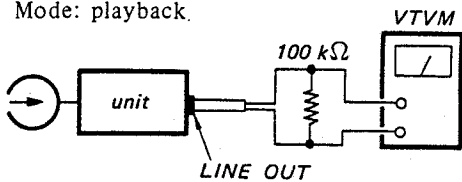

4. Be sure that VTVM reading is less than -48 dB (3 mV).

**Note:** S/N ratio may change by reversing the sense of motor leads.

**9. Record Head Azimuth and Track Position Adjustment**

**Control/Switch Setting:**

TAPE SELECT switch: NORMAL  
 TAPE SPEED selector: 7½ ips (19 cm/s)  
 MONITOR switch: TAPE  
 LINE RECORD  
 VOLUME control: See page 16

**Procedure:**

1. Mode: record

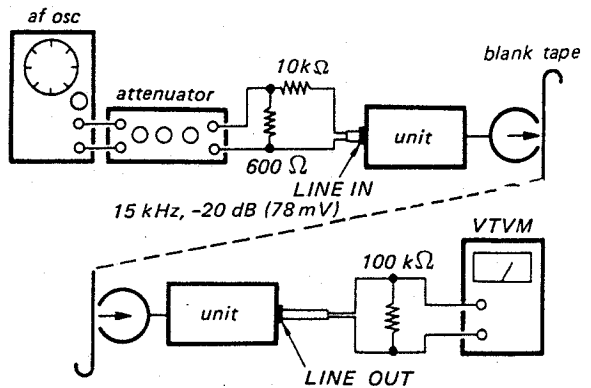

2. Adjust azimuth adjusting screw for maximum VTVM reading.

**Note:** If the maximum value of L-CH and R-CH outputs can not be obtained at the same angle, adjust the screw midway between two screw positions. (That value should not be fallen more than 1 dB from the maximum value.)

3. Supply a 1 kHz signal of -10 dB (0.24 V) into R-CH LINE IN jack and record the signal on the blank tape.
4. Adjust the height adjusting screw for maximum VTVM reading and memorize the angle of turns of the screw.
5. Turn the zenith adjusting screw by the same angle of turns obtained in preceding step 4.
6. After the adjustment, check tape path adjustment on page 17 again.

**Adjustment Location:**

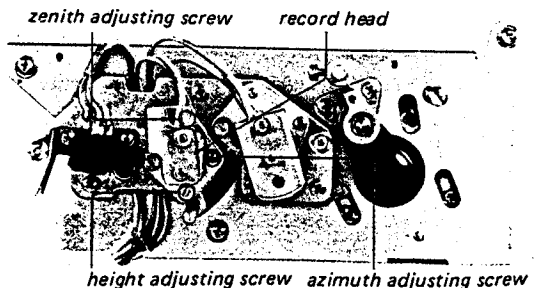



**10. Record Head Phase Check**

**Control/Switch Setting:**

- TAPE SELECT switch: NORMAL
- TAPE SPEED selector: 7½ ips (19 cm/s)
- MONITOR switch: TAPE
- LINE RECORD
- VOLUME control: See page 16

**Procedure:**

1. Make the playback head phase check on page 19 first.
2. Mode: record

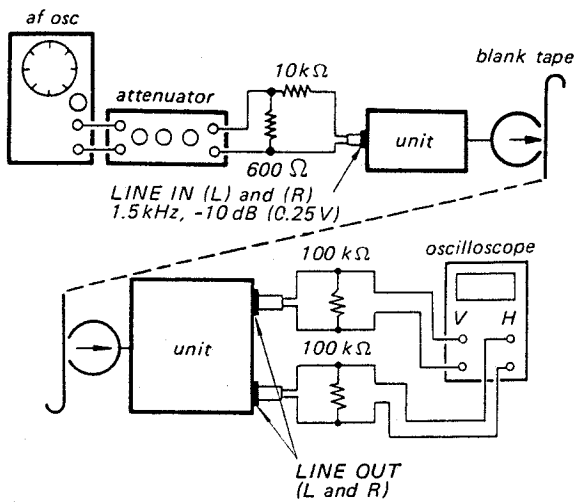

3.

Adjust	On the oscilloscope
azimuth adjusting screw	

**Note:** If necessary, finely adjust record head azimuth adjusting screw.

**11. Trap Coil Adjustment**

**Control/Switch Setting:**

- TAPE SELECT switch: NORMAL
- TAPE SPEED selector: 7½ ips (19 cm/s)
- MIC RECORD
- VOLUME control: MIN (fully counterclockwise)

**Procedure:**

1. Connect a VTVM across the check point and ground as shown.

(RECORD AMP CIRCUIT BOARD)

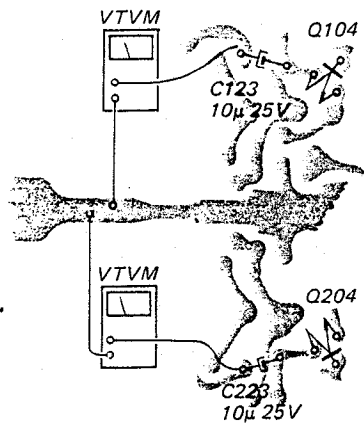

2. Place unit in record mode without tape.
3. Adjust L104, L204 to obtain the minimum VTVM reading (less than -7 dB, 0.35V).

**Adjustment Location:**

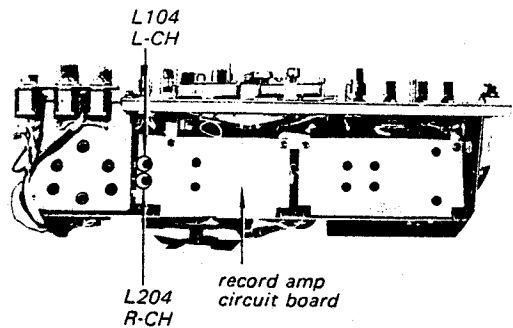

**12. Record Bias Adjustment**

**Control/Switch Setting:**

- TAPE SELECT switch: NORMAL
- TAPE SPEED selector: 7½ ips (19 cm/s)
- MONITOR switch: TAPE
- LINE RECORD
- VOLUME control: See page 16

**Procedure:**

1. Be sure that trap coil adjustment has been made.
2. Mode: record

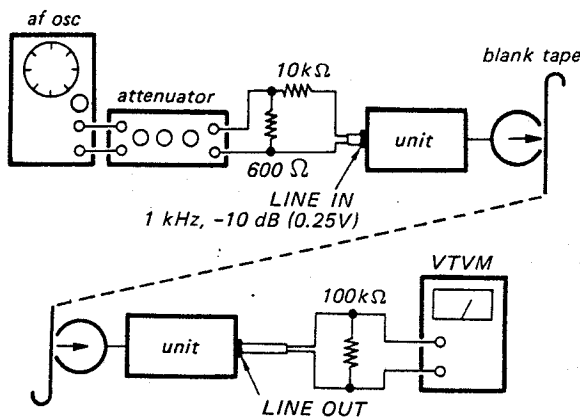

3. Turn the bias adjusting trimmer capacitors C503, C504 counterclockwise for maximum VTVM reading and then turn the capacitor counterclockwise so that VTVM reading drops 0.5 dB from the maximum value.
4. After the adjustment, be sure that voltage across record head is approximately 14V on VTVM and it decreases, as TAPE SPEED selector is changed to 3¼ ips (9.5 cm/s) and then 1⅞ ips (4.8 cm/s).

**Adjustment Location:**

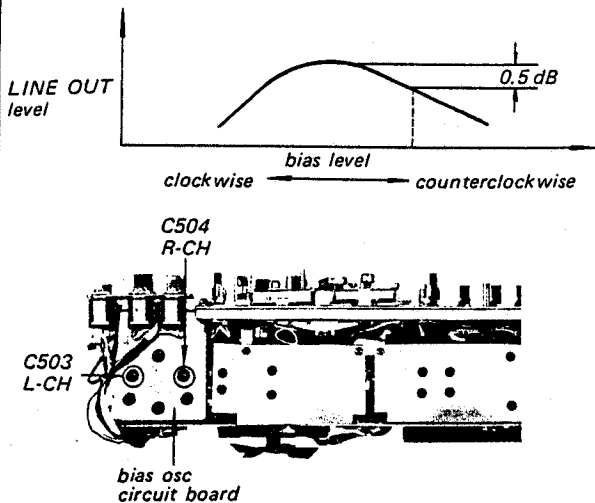

**13. Record Level Adjustment**

**Control/Switch Setting:**

- TAPE SELECT switch: NORMAL
- TAPE SPEED selector: 7½ ips (19 cm/s)
- MONITOR switch: TAPE
- LINE RECORD
- VOLUME control: See page 16

**Procedure:**

1. Mode: record

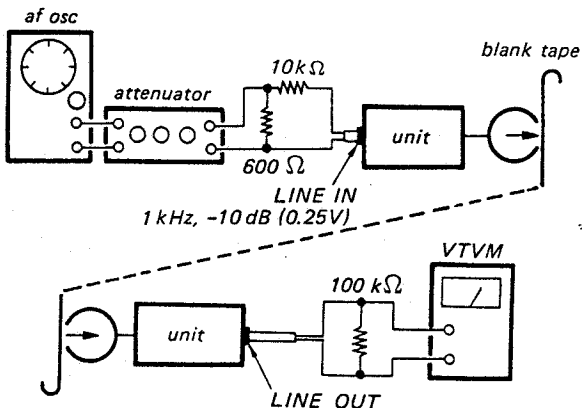

2. Adjust R128, R228 for 0 dB (0.78V) VTVM reading.
3. Be sure that VTVM reading is 0 dB (0.78V) when changing MONITOR switch from TAPE to SOURCE position and the pointer of RECORD LEVEL meter stays at "0".
4. When TAPE SELECT switch is changed to SPECIAL with MONITOR switch to SOURCE, VTVM reading should decrease approx. 1.5 dB.

**Adjustment Location:**

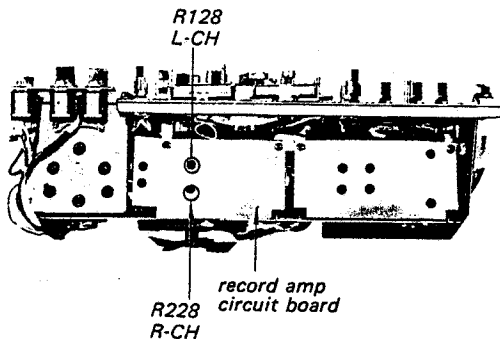

**14. Dummy Coil Adjustment**

**Control/Switch Setting:**

- TAPE SELECT switch: NORMAL
- TAPE SPEED selector: 7½ ips (19 cm/s)
- MONITOR switch: TAPE
- LINE RECORD
- VOLUME control: See page 16

**Procedure:**

1. Mode: stereo record

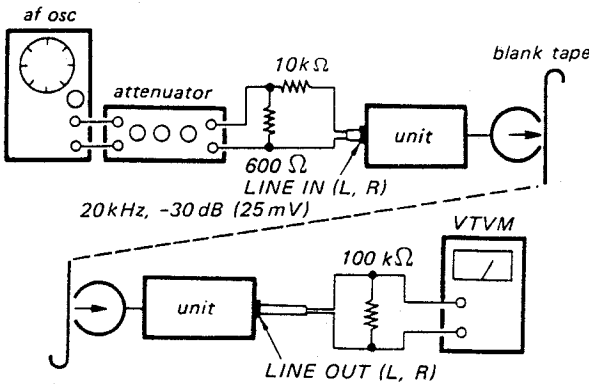

2. Memorize VTVM readings.
3. Set L-channel (R-channel) only in record mode.
4. Adjust L502 (L501) with non-magnetic screwdriver, taking care not to break the core, so that VTVM reading is the same as that obtained in step 2.

**Adjustment Location:**

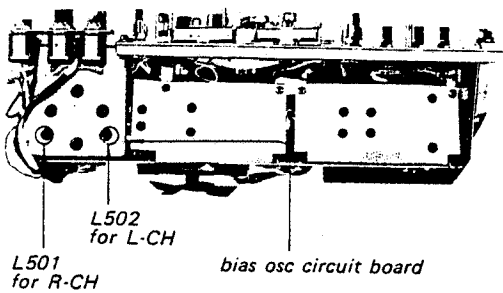

**15. Erase Ratio Measurement**

**Control/Switch Setting:**

- TAPE SELECT switch: NORMAL
- TAPE SPEED selector: 7½ ips (19 cm/s)
- MONITOR switch: TAPE
- LINE RECORD
- VOLUME control: See page 16

**Procedure:**

1. Mode: stereo record

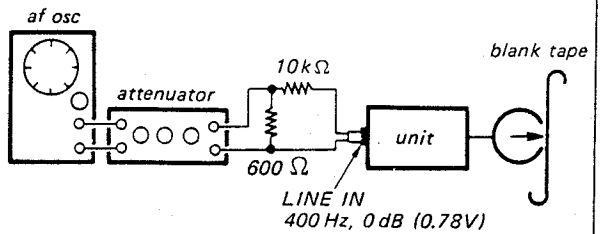

2. Rewind half of the recorded part.
3. Mode: stereo record (erase)

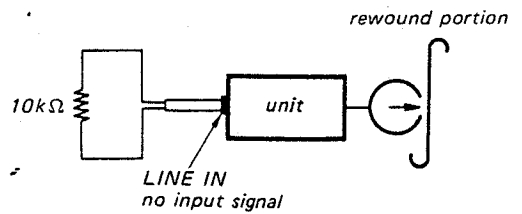

4. Mode: playback

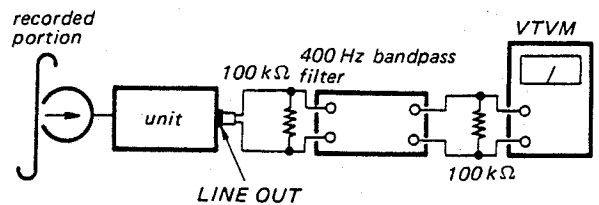

**Specification:**

Recorded Signal	VTVM Reading
1 kHz	level difference: greater than 65 dB
erased portion	

**16. Overall Frequency Response Measurement**

**Control/Switch Setting:**

- TAPE SELECT switch: NORMAL and SPECIAL
- TAPE SPEED selector: 7½ ips (19 cm/s)  
3¾ ips (9.5 cm/s)  
and 17⁄8 ips (4.8 cm/s)
- MONITOR switch: TAPE
- LINE RECORD
- VOLUME control: See page 16

**Procedure:**

1. Mode: record

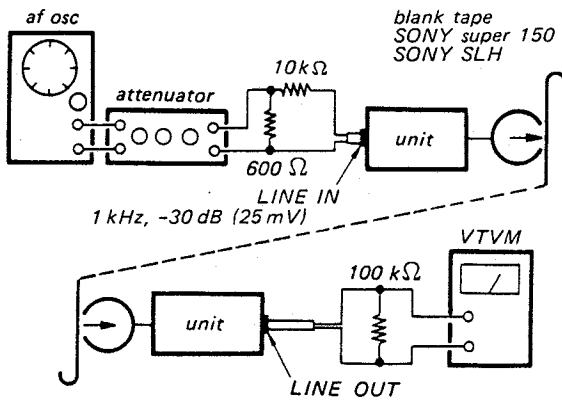

2. Level Deviation from 1 kHz signal.  
(for both SPECIAL and NORMAL)

Frequency Tape speed	50 Hz	100 Hz	5 kHz	7 kHz	12.5 kHz	20 kHz
19 cm/s	±3 dB	±3	±3	±3	±3	+3 -4
9.5 cm/s	+3 -6	±3	±3	±3	+3 -4	
4.8 cm/s	+4 -5	+5 -1	+1 -6			

**Note:** When recording signal on SONY tape "super 150", set TAPE SELECT switch to NORMAL and on SONY SLH tape, to SPECIAL.

**17. Overall S/N Ratio Measurement**

**Control/Switch Setting:**

- TAPE SELECT switch: NORMAL and SPECIAL
- TAPE SPEED selector: 7½ ips (19 cm/s)
- MONITOR switch: TAPE
- MIC RECORD
- VOLUME control: See page 16

**Procedure:**

1. Mode: record

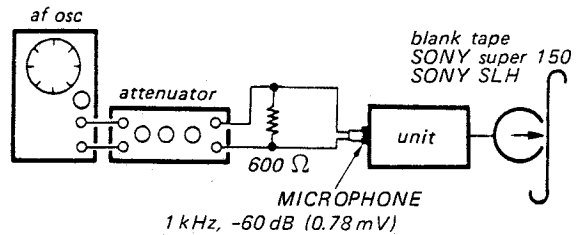

2. Mode: record

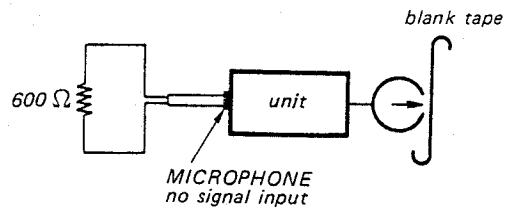

3. Mode: playback

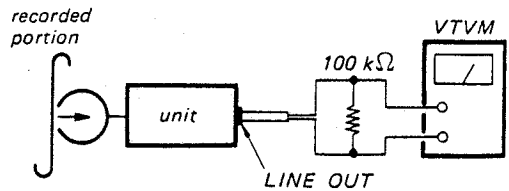

**Specification:**

Recorded Signal	VTVM Reading	
	NORMAL	SPECIAL
1 kHz	level difference: greater than 45 dB	level difference: greater than 47 dB
no signal		

**Note:** When recording signal on SONY tape "super 150", set TAPE SELECT switch to NORMAL and on SONY SLH tape, to SPECIAL.

**For Service Manuals**  
**MAURITRON SERVICES**  
 8 Cherry Tree Road, Chinnor  
 Oxfordshire, OX2 4QY.  
 Tel (01844) 351694  
 Fax (01844) 352554  
 email:- mauritron@dial.pipex.com

**18. Overall Distortion Measurement**

**Control/Switch Setting:**

- TAPE SELECT switch: NORMAL
- TAPE SPEED selector: 7 1/2 ips (19 cm/s)
- MONITOR switch: TAPE
- LINE RECORD
- VOLUME control: See page 16

**Procedure:**

1. Mode: record

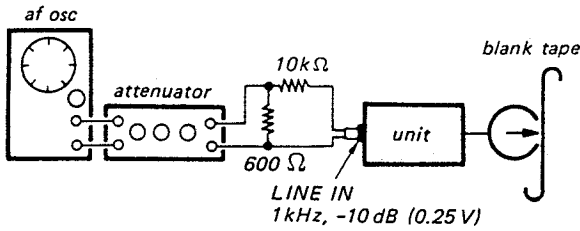

2. Mode: playback

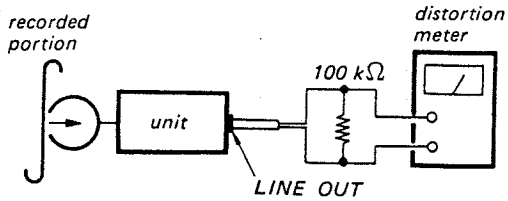

Specification: less than 1.5%

**19. Cross-talk Measurement (between channels)**

**Control/Switch Setting:**

- TAPE SELECT switch: NORMAL
- TAPE SPEED selector: 7 1/2 ips (19 cm/s)
- MONITOR switch: TAPE
- LINE RECORD
- VOLUME control: See page 16

**Procedure:**

1. Mode: stereo record

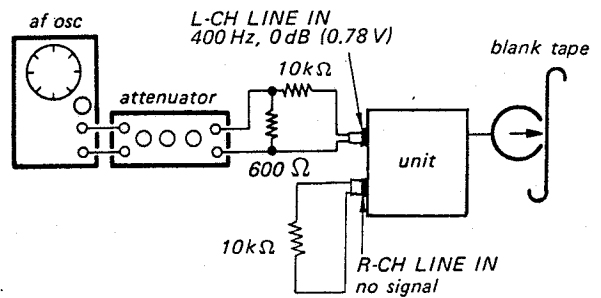

2. Mode: playback

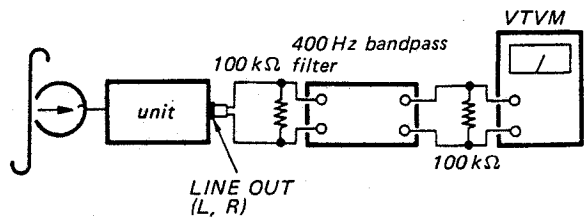

Specification:

Playback	VTVM Reading
L-CH (400 Hz)	level difference: greater than 48 dB
R-CH (no signal)	

**20. Cross-Talk Measurement  
(between tracks)**

**Control/Switch Setting:**

- TAPE SELECT switch: NORMAL
- TAPE SPEED selector: 7 1/2 ips (19 cm/s)
- MONITOR switch: TAPE
- LINE RECORD
- VOLUME control: See page 16

**Procedure:**

1. Mode: stereo record

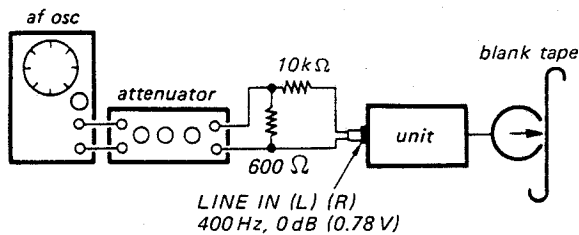

2. Turn the reels over.
3. Mode: playback

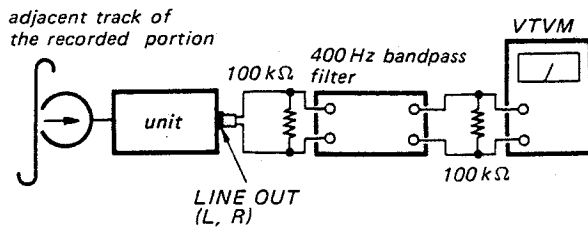

**Specification:**

Playback	VTVM reading
400 Hz	level difference: greater than 65 dB
adjacent track of the recorded portion	

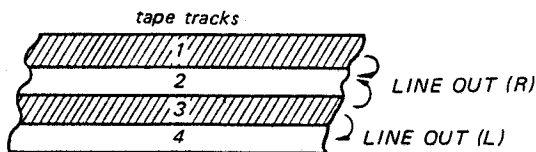

**21. Minimum Input Level Check**

**Control/Switch Setting:**

MONITOR switch: SOURCE

**Procedure:**

**A. MICROPHONE Jack Level Check**

1. Set LINE RECORD VOLUME to MIN and MIC RECORD VOLUME to MAX position.
2. Supply 1 kHz signal into MICROPHONE jack and adjust attenuator to obtain 0 dB (0.78 V) VTVM reading.
3. Be sure that MICROPHONE jack level is less than -72 dB (0.2 mV).

**B. LINE IN Jack Level Check**

1. Set MIC RECORD VOLUME to MIN and LINE RECORD VOLUME to MAX position.
2. Supply 1 kHz signal into LINE IN jack and adjust attenuator to obtain 0 dB (0.78 V) VTVM reading.
3. Be sure that LINE IN jack level is less than -22 dB (61.5 mV).

**Mode: record**

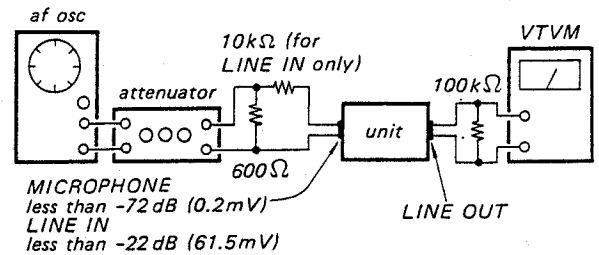

**3-3. POWER FREQUENCY ADAPTATION**

The motor pulley and tapping of the motor capacitor terminals must be changed, if the line frequency differs from what the recorder is set for.

**To change connection of the motor capacitor terminals**

The motor capacitor is located at the upper side of the drive mechanism. Change the connection of the motor capacitor terminals by soldering as illustrated.

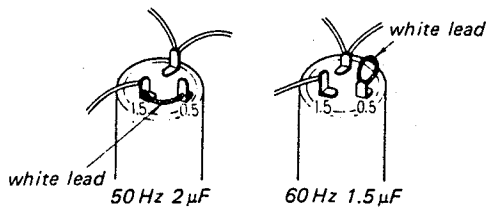

**To change motor pulley**

Remove the top panel as described in DISASSEMBLY on page 6.

1. Remove PAUSE adjusting plate by loosening the screw (A). Withdraw PAUSE pull rod.
2. Remove rubber belt from the motor pulley and idler wheel.
3. Remove motor pulley by loosening two screws (B) and (C) which hold motor pulley.
4. Use the supplied motor pulley with same mark and tighten the screws.

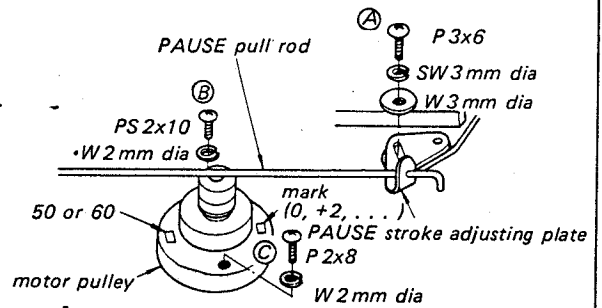

Motor Pulley Part No.			
for 50 Hz		for 60 Hz	
Mark on Motor Pulley	Part No.	Mark on Motor Pulley	Part No.
+2	3-518-067-61	+2	3-518-068-61
+1	3-518-067-51	+1	3-518-068-51
+0.5	3-518-067-41	+0.5	3-518-068-41
0	3-518-067-01	0	3-518-068-01
-0.5	3-518-067-11	-0.5	3-518-068-11
-1	3-518-067-21	-1	3-518-068-21
-2	3-518-067-31	-2	3-518-068-31

SECTION 4  
DIAGRAMS

4-1. LEVEL DIAGRAMMS

Playback

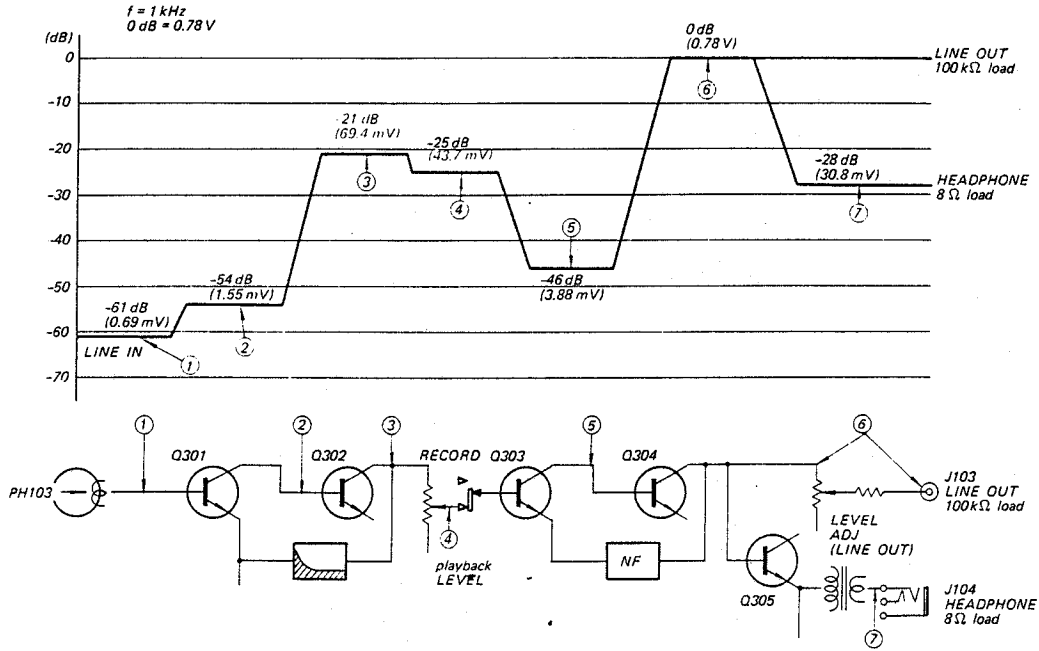

Record

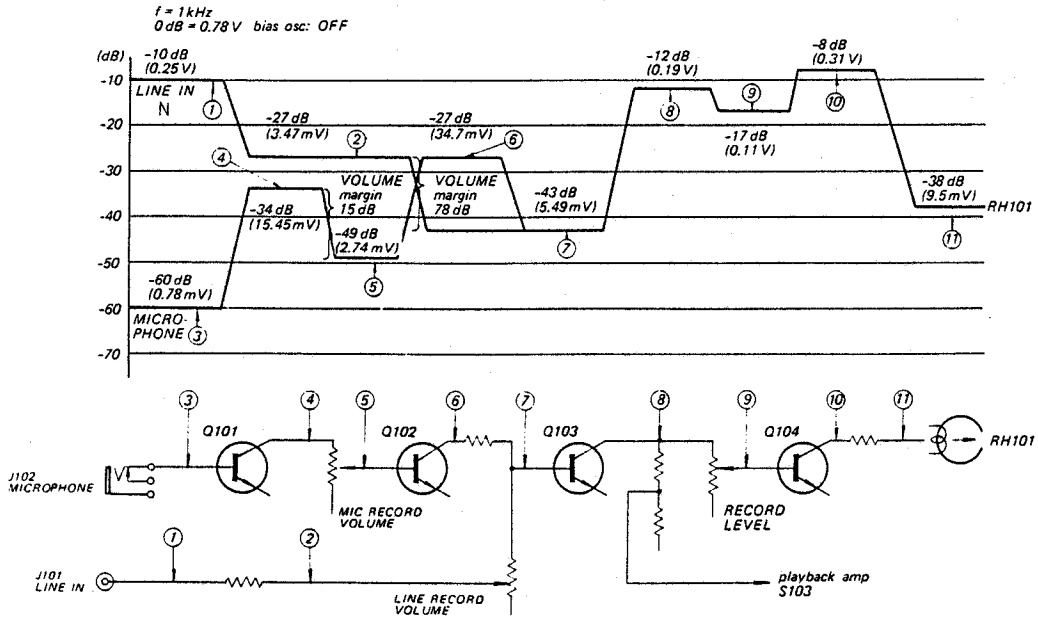





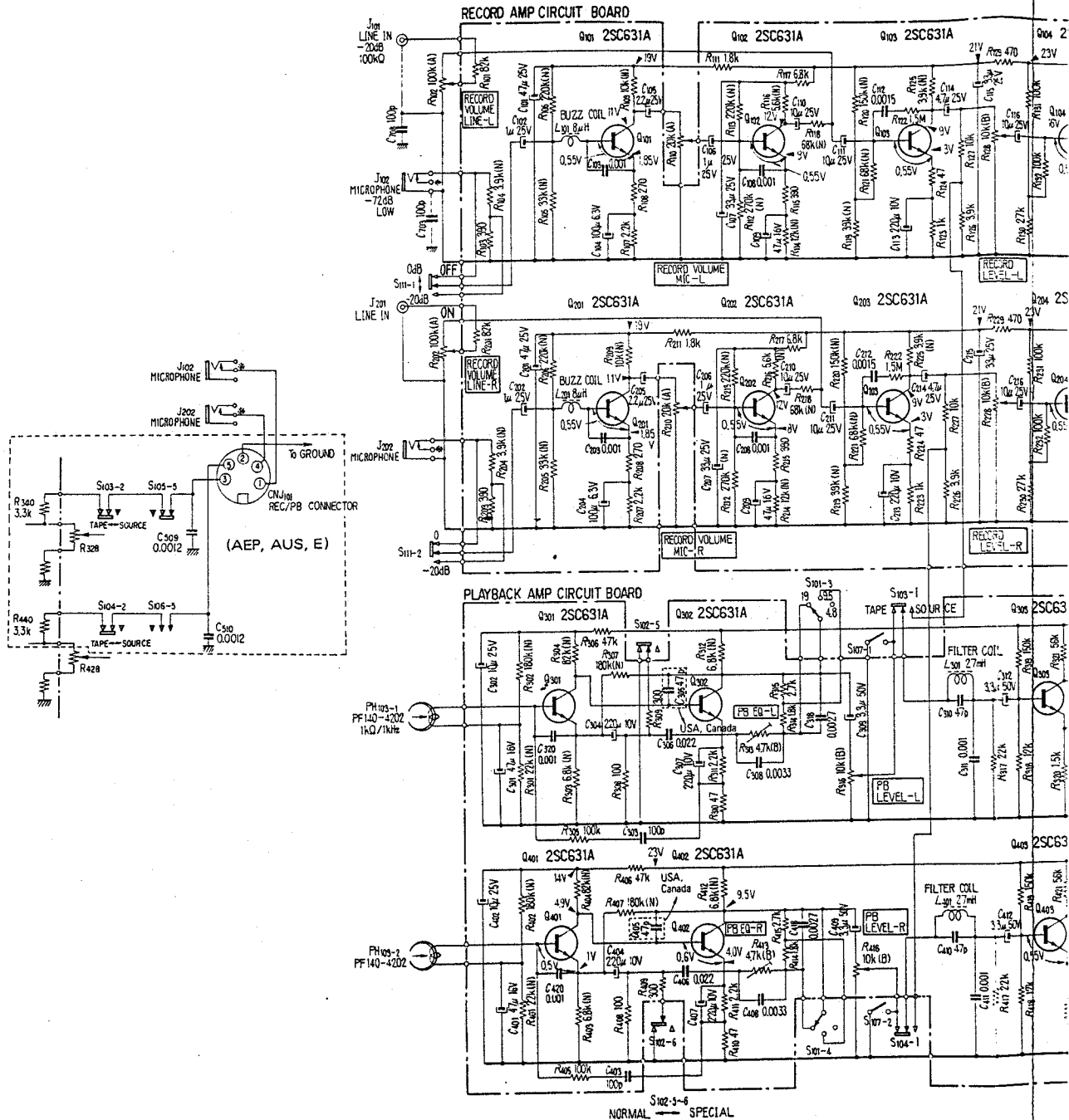

4-2. SCHEMATIC DIAGRAM



- Note:**
1. All resistors and capacitors are rated in  $\Omega$  and  $\mu F$ , unless otherwise specified.
  2. The letter (A), (B) suffixed to rating value of variable or adjustable resistor indicates its characteristics.
  3. Voltage values shown are measured with a voltmeter (20  $k\Omega/V$ ) in playback mode. Voltage and current values in ( ) are measured in record mode. Variations may be because of normal production tolerances.
  4. Symbols  
 : Chassis ground  
 (N) : Low noise resistor

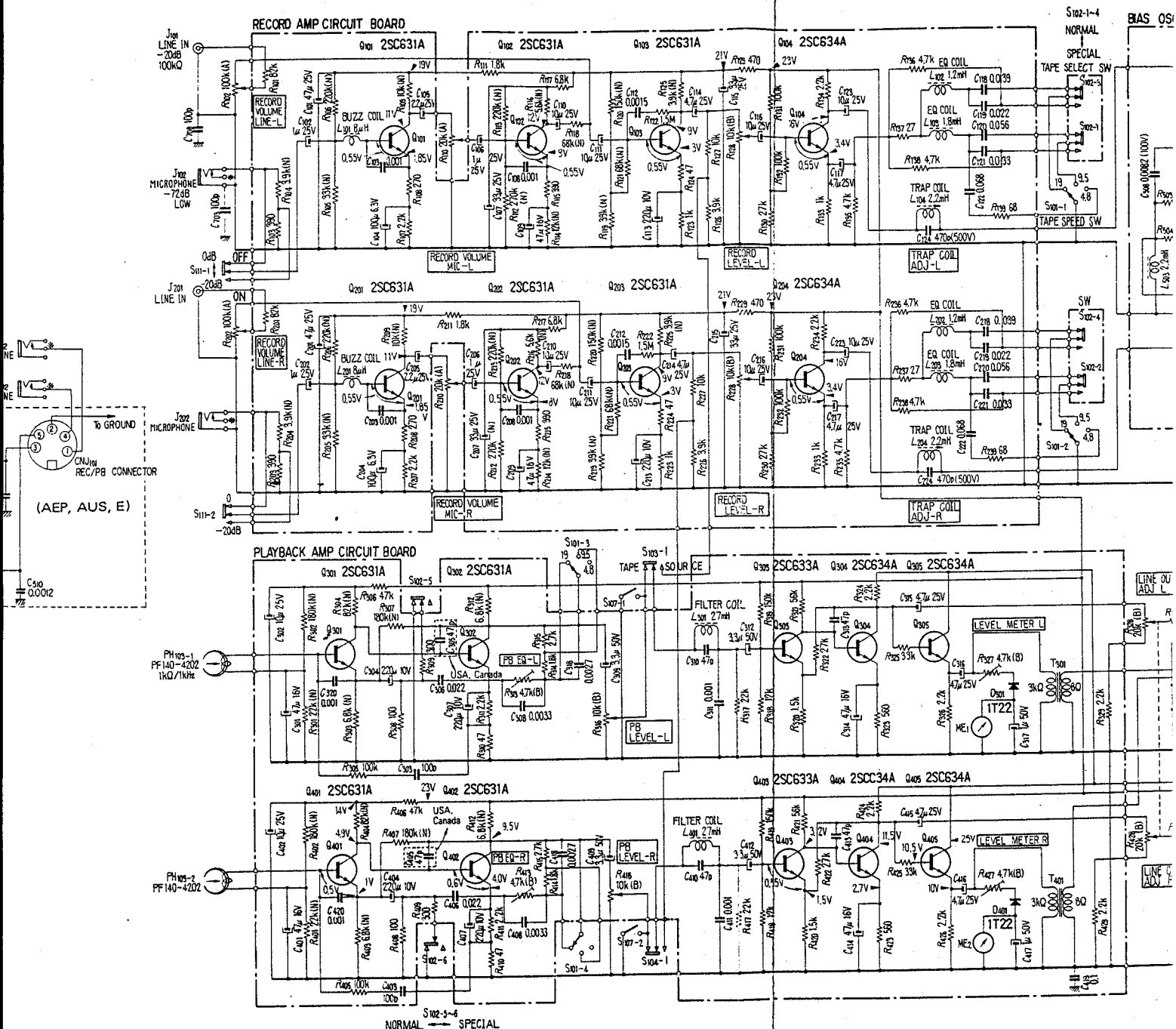

**Note:**

1. All resistors and capacitors are rated in  $\Omega$  and  $\mu F$ , unless otherwise specified.
2. The letter (A), (B) suffixed to rating value of variable or adjustable resistor indicates its characteristics.
3. Voltage values shown are measured with a voltmeter (20 k $\Omega$ /V) in playback mode. Voltage and current values in ( ) are measured in record mode. Variations may be noted because of normal production tolerances.
4. Symbols  
 ⏏ : Chassis ground  
 (N) : Low noise resistor

**5. Switch position**

Ref. No.	Description
S101	TAPE SPEED
S102	TAPE SELECT
S103	MONITOR (L-CHANNEL)
S104	MONITOR (R-CHANNEL)
S105	record/playback (L-channel)
S106	record/playback (R-channel)
S107	muting
S108	bias osc
S109	POWER
S110	auto shut-off
S111	MIC ATT

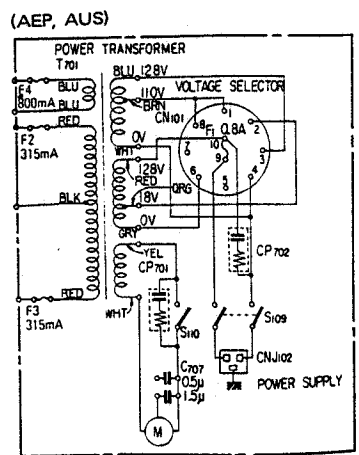
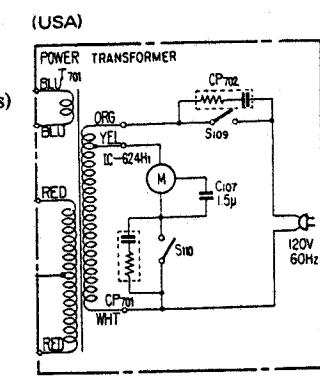
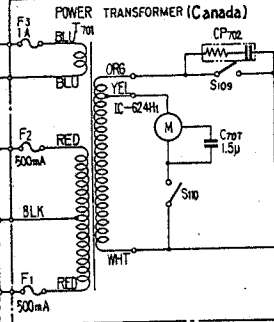
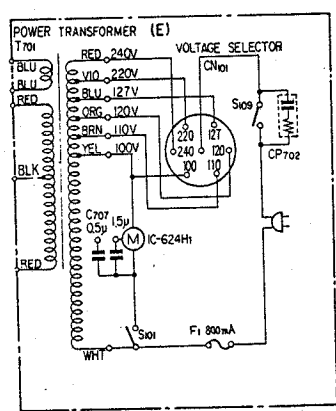
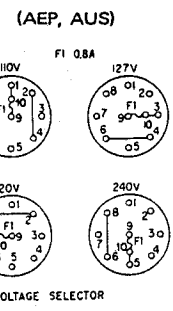
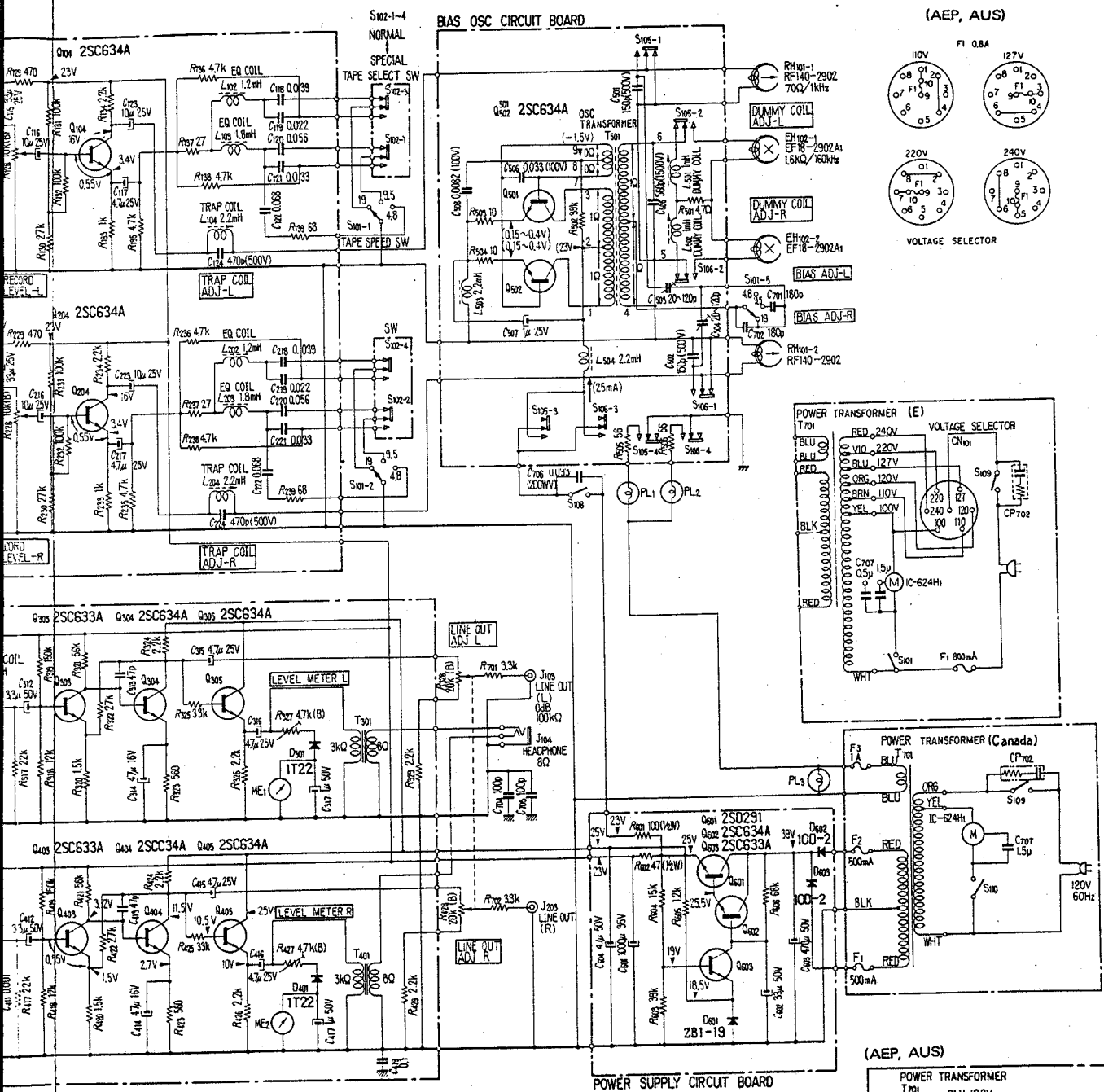

5. Switch position

Ref. No.	Description	Position
S101	TAPE SPEED	19 cm/sec (7 1/2 ips)
S102	TAPE SELECT	NORMAL
S103	MONITOR (L-CHANNEL)	TAPE
S104	MONITOR (R-CHANNEL)	TAPE
S105	record/playback (L-channel)	playback
S106	record/playback (R-channel)	playback
S107	muting	OFF
S108	bias osc	OFF
S109	POWER	OFF
S110	auto shut-off	OFF
S111	MIC ATT	OFF

4-3. MOUNTING DIAGRAMS

4-3-1. Tape Select Switch Circuit Board

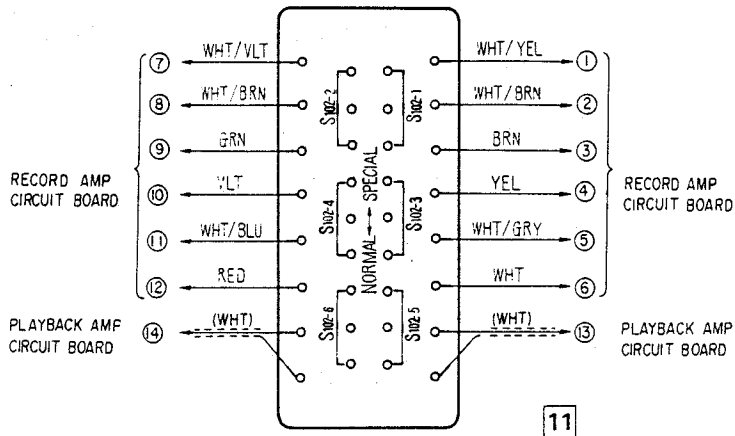

4-3-2. Power Supply Circuit Board

Conductor Side

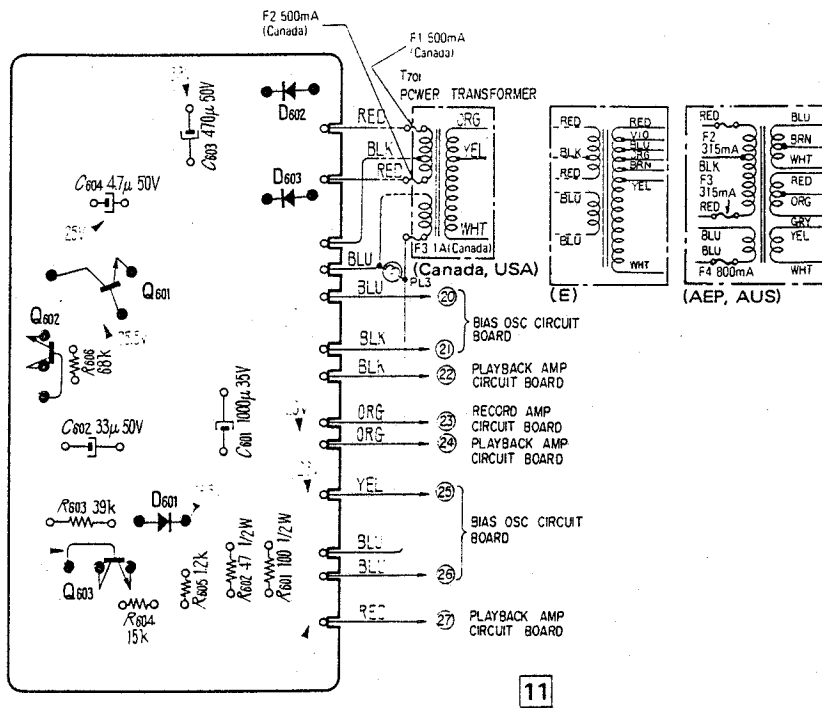

- Q601: 2SD291
- Q602: 2SC634A
- Q603: 2SC633A
- D601: ZB1-19
- D602, 603: 10D-2

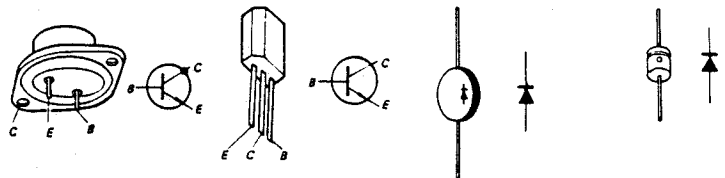

For Service Manuals  
**MAURITRON SERVICES**  
 8 Cherry Tree Road, Chinnor  
 Oxfordshire, OX9 4QY.  
 Tel (01844) 351694  
 Fax (01844) 352554  
 email: mauritron@dial.pipex.com

**4-3-3. Bias Osc Circuit Board**

*Conductor Side*

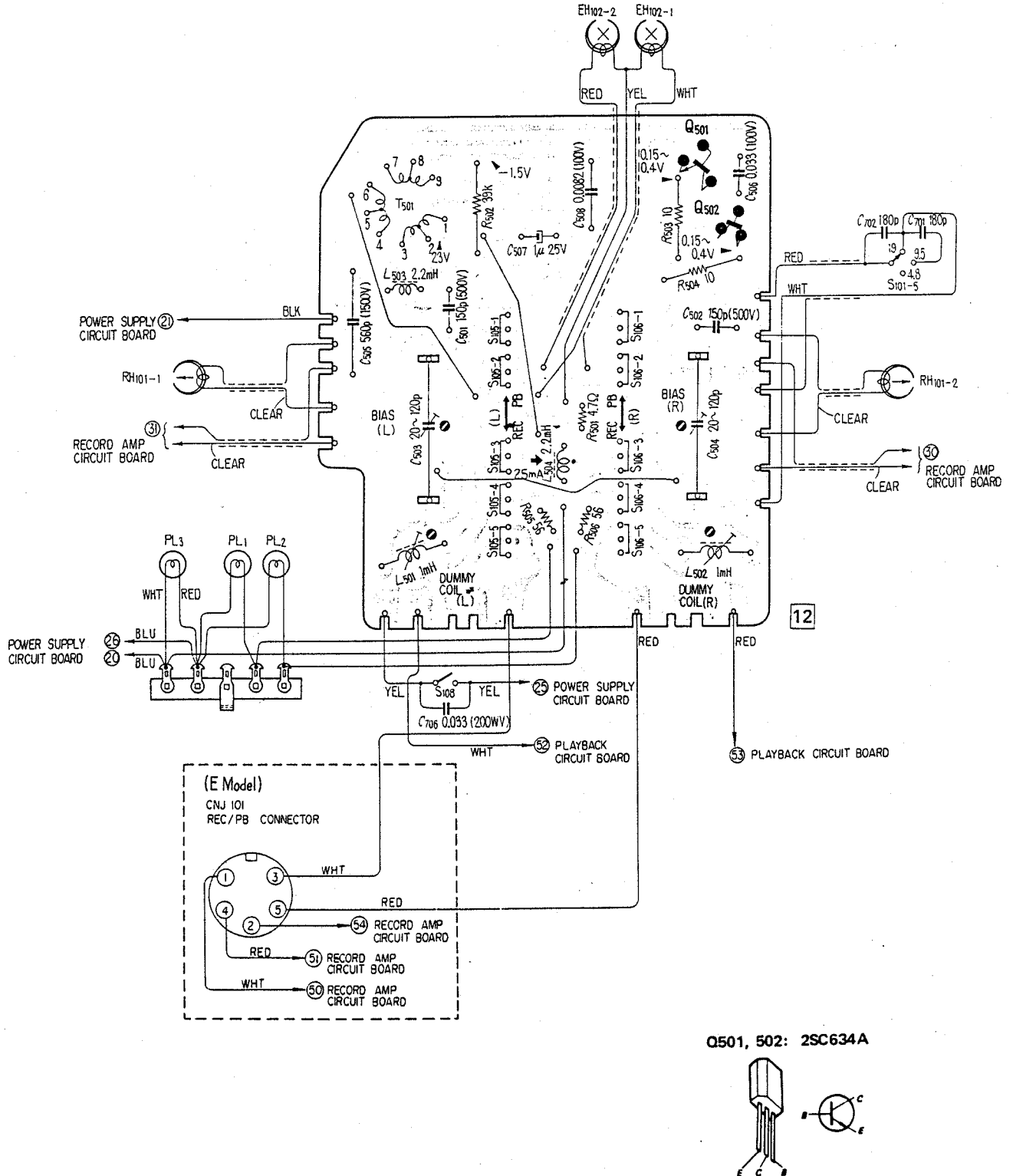



4-3-5. Playback Amp Circuit Board  
Conductor Side

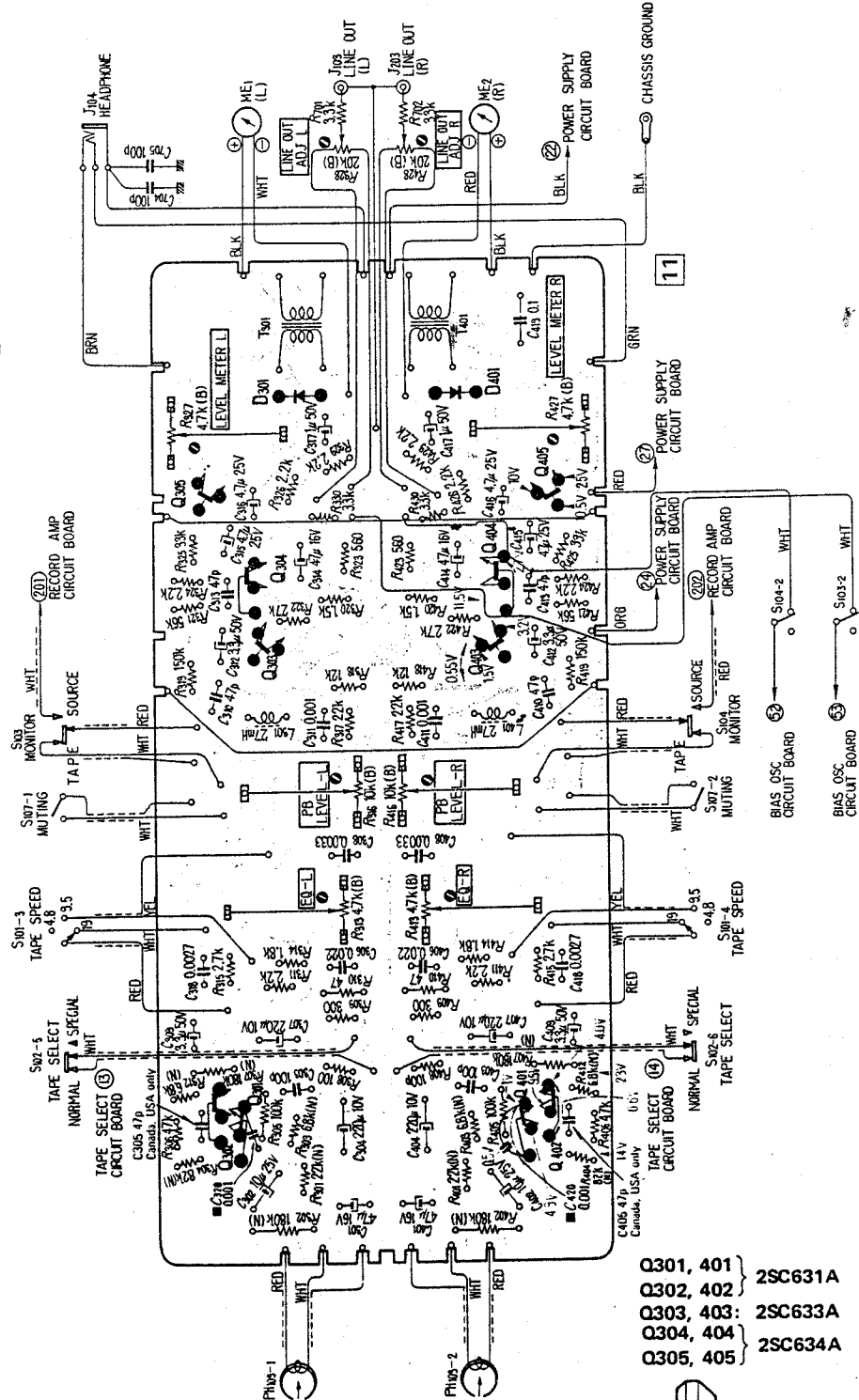

■ : Mounted on the Conductor Side of Playback Amp Circuit Board.

- Q301, 401 } 2SC631A
- Q302, 402 } 2SC631A
- Q303, 403 } 2SC633A
- Q304, 404 } 2SC633A
- Q305, 405 } 2SC634A
- D301, 401: 1T22

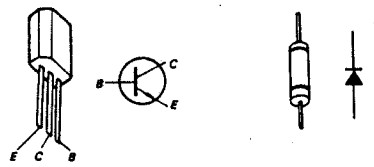



## SECTION 5 EXPLODED VIEWS

### 5-1. CABINET – Top View –

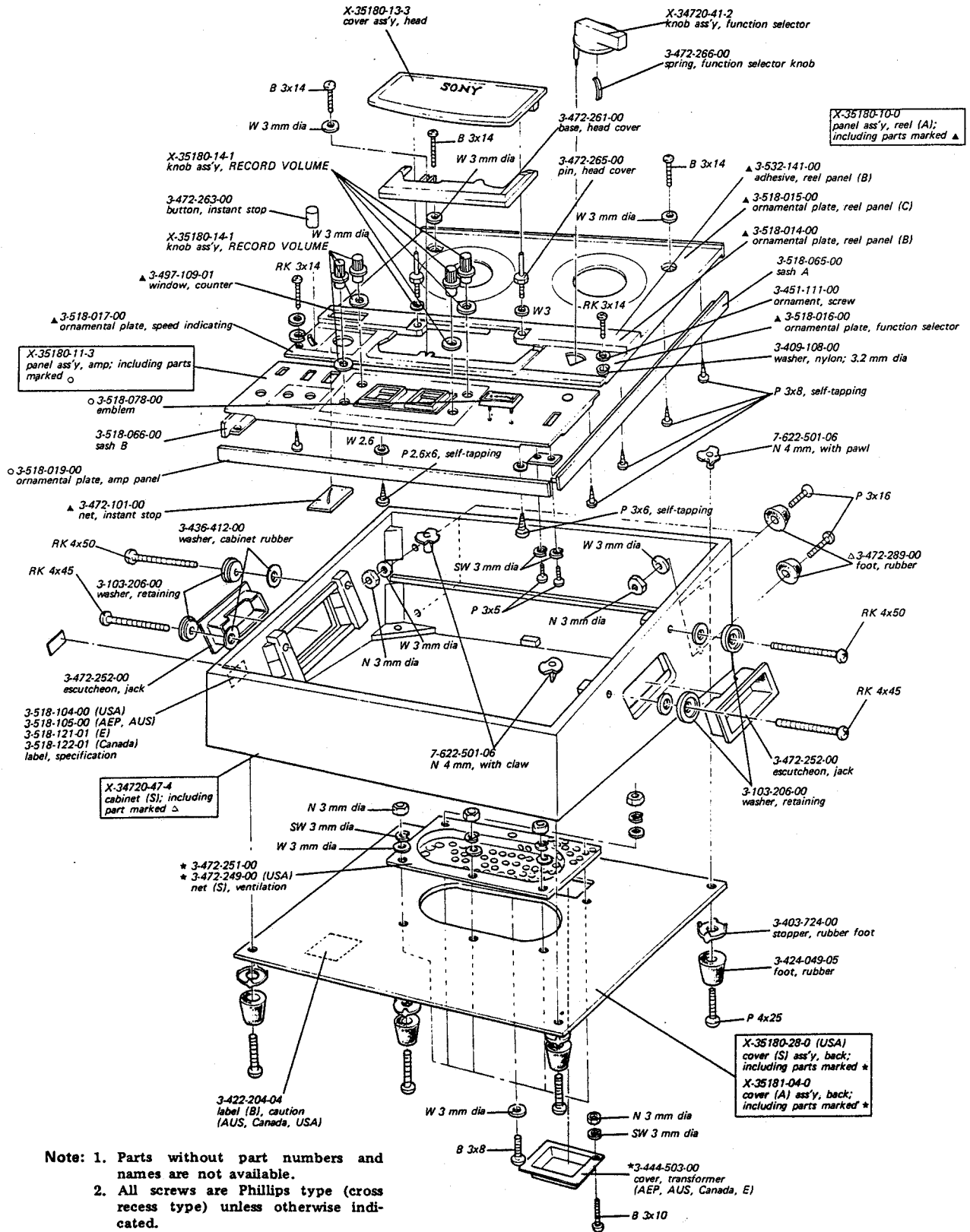

**Note:** 1. Parts without part numbers and names are not available.  
2. All screws are Phillips type (cross recess type) unless otherwise indicated.  
(-): slotted head



5-3. AMPLIFIER CHASSIS — Top View —

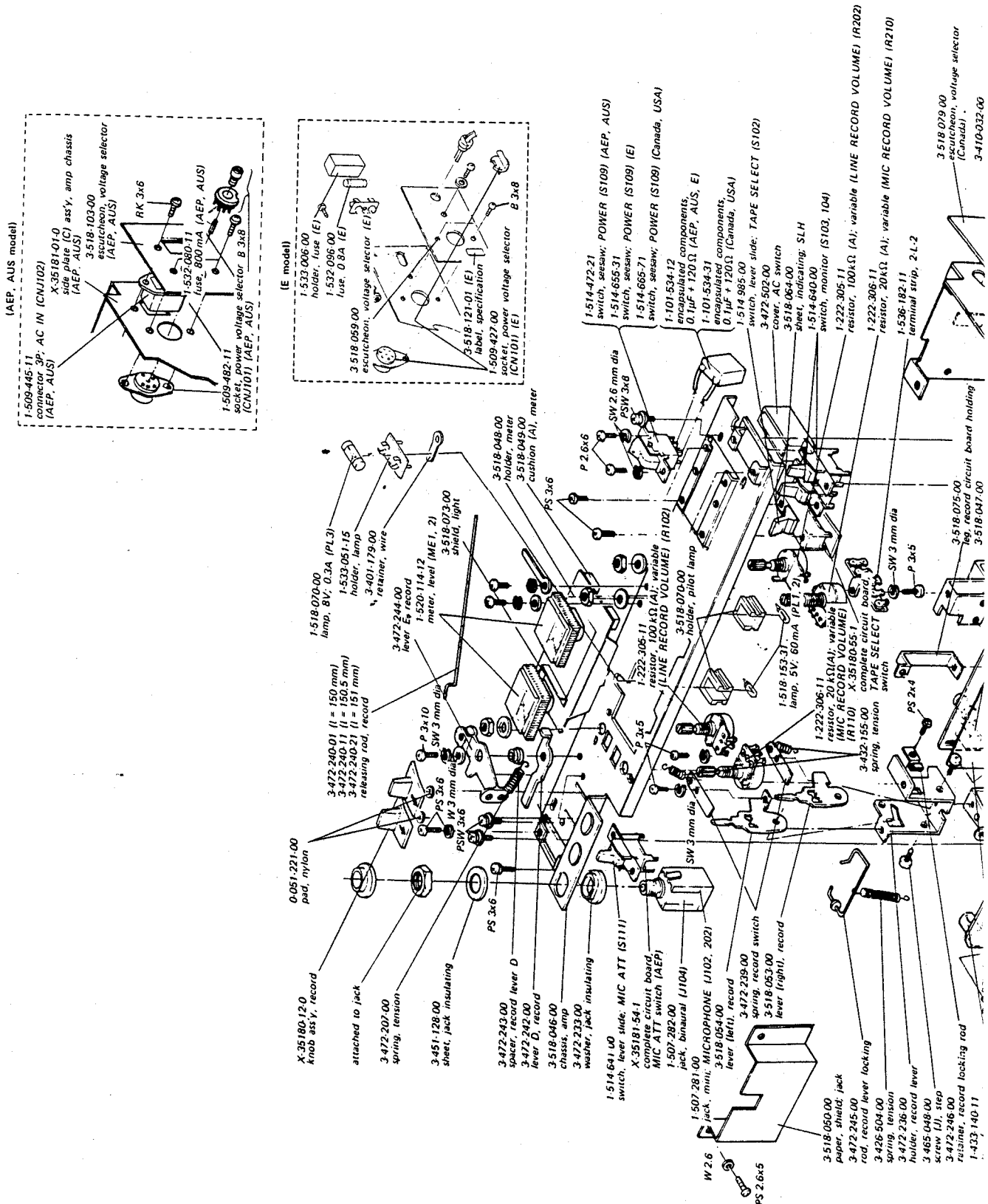









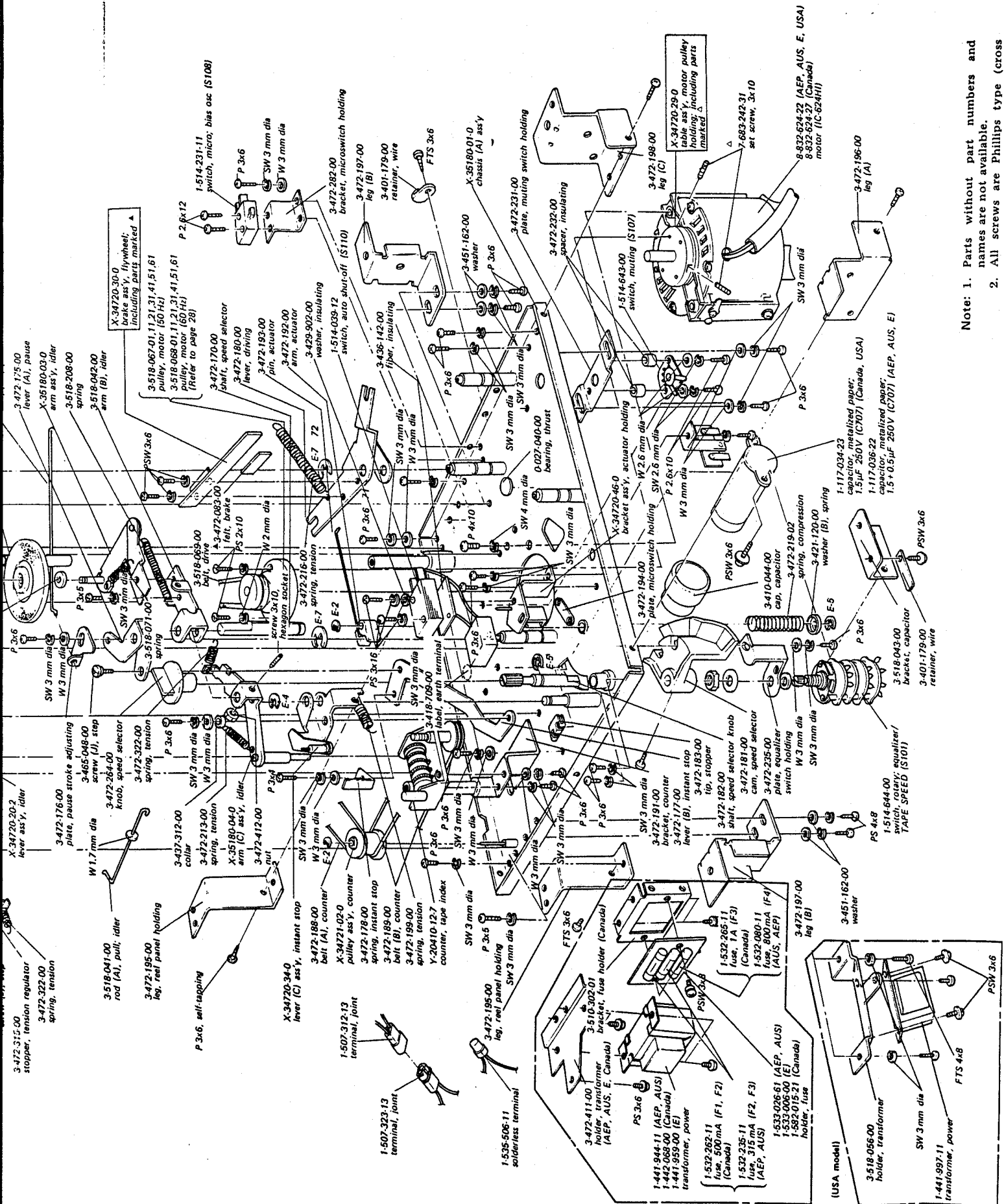

Note: 1. Parts without part numbers and names are not available.  
 2. All screws are Phillips type (cross)



## 5-5. PACKING

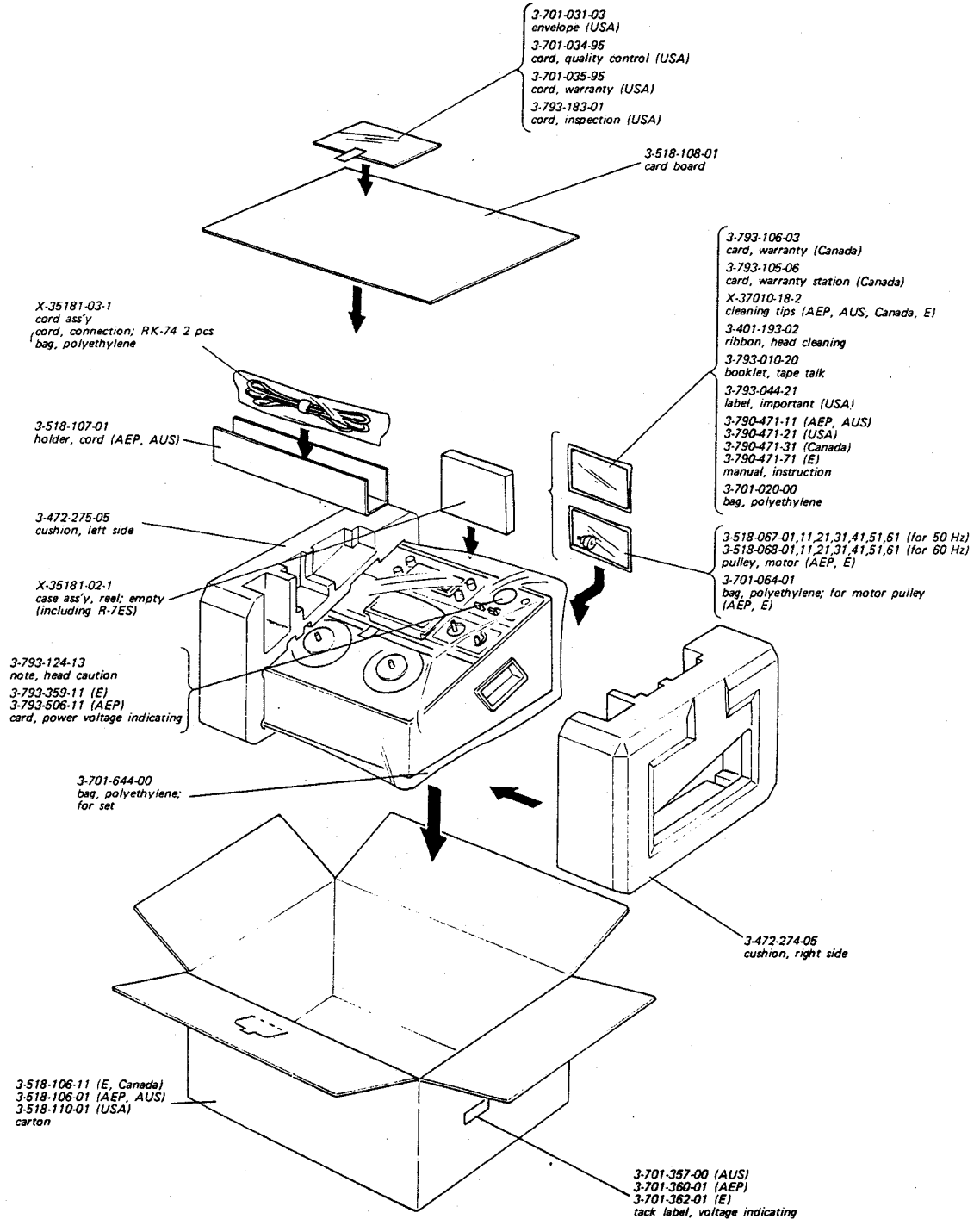

- Note:**
1. Parts without part numbers and names are not available.
  2. All screws are Phillips type (cross recess type) unless otherwise indicated.  
(-): slotted head

**SECTION 6  
ELECTRICAL PARTS LIST**

<u>Ref. No.</u>	<u>Part No.</u>	<u>Description</u>
<b>COMPLETE CIRCUIT BOARDS</b>		
X-35180-51-1		record amp (Canada, USA)
X-35180-52-1		playback amp (Canada, USA)
X-35180-53-1		power supply
X-35180-54-1		bias osc (Canada, USA)
X-35180-55-1		TAPE SELECT switch
X-35181-51-1		record amp (AEP, AUS, E)
X-35181-52-1		playback amp (AEP, AUS, E)
X-35181-53-1		bias osc (AEP, AUS, E)

<b>SEMICONDUCTORS</b>		
<u>Ref. No.</u>	<u>Part No.</u>	<u>Description</u>
Q101, 201	transistor	2SC631A
Q102, 202	transistor	2SC631A
Q103, 203	transistor	2SC631A
Q104, 204	transistor	2SC634A
Q301, 401	transistor	2SC631A
Q302, 402	transistor	2SC631A
Q303, 403	transistor	2SC633A
Q304, 404	transistor	2SC634A
Q305, 405	transistor	2SC634A
Q501	transistor	2SC634A
Q502	transistor	2SC634A
Q601	transistor	2SD291
Q602	transistor	2SC634A
Q603	transistor	2SC633A
D301, 401	diode	1T-22
D601	diode	ZB1-19
D602	diode	10D-2
D603	diode	10D-2

<b>COILS</b>		
<u>Ref. No.</u>	<u>Part No.</u>	<u>Description</u>
L101, 201	1-407-519-11	inductor, micro 8 $\mu$ H
L102, 202	1-407-493-21	inductor, micro 1.2 mH
L103, 203	1-407-495-21	inductor, micro 1.8 mH
L104, 204	1-407-286-11	coil, trap 2.2 mH
L301, 401	1-407-593-11	inductor, micro 27 mH
L501	1-407-284-00	coil, dummy 1 mH
L502	1-407-284-00	coil, dummy 1 mH

<u>Ref. No.</u>	<u>Part No.</u>	<u>Description</u>
L503	1-407-198-21	inductor, micro 2.2 mH
L504	1-407-198-21	inductor, micro 2.2 mH

<b>TRANSFORMERS</b>		
<u>Ref. No.</u>	<u>Part No.</u>	<u>Description</u>
T301, 401	1-427-299-00	output
T501	1-433-140-11	bias osc
T701	1-441-997-11	power (USA)
	1-441-944-11	power (AEP, AUS)
	1-441-959-00	power (E)
	1-442-068-00	power (Canada)

<b>CAPACITORS</b>					
All capacitors are microfarads unless otherwise noted. (p = $\mu$ F, elect = electrolytic)					
<u>Ref. No.</u>	<u>Part No.</u>	<u>Value</u>	<u>Voltage</u>	<u>Material</u>	<u>Description</u>
C101, 201	1-121-410-11	47	25V	elect	
C102, 202	1-127-094-11	1	25V	solid aluminum	elect
C103, 203	1-105-821-12	0.001	50V	mylar	
C104, 204	1-121-413-11	100	6.3V	elect	
C105, 205	1-127-095-11	2.2	25V	solid aluminum	elect
C106, 206	1-127-094-11	1	25V	solid aluminum	elect
C107, 207	1-121-404-11	33	25V	elect	
C108, 208	1-105-821-12	0.001	50V	mylar	
C109, 209	1-121-409-11	47	16V	elect	
C110, 210	1-121-398-11	10	25V	elect	
C111, 211	1-121-398-11	10	25V	elect	
C112, 212	1-105-663-12	0.0015	50V	mylar	
C113, 213	1-121-420-11	220	10V	elect	
C114, 214	1-121-395-11	4.7	25V	elect	
C115, 215	1-121-404-11	33	25V	elect	
C116, 216	1-121-398-11	10	25V	elect	
C117, 217	1-121-395-11	4.7	25V	elect	
C118, 218	1-105-520-12	0.039	50V	mylar	
C119, 219	1-105-517-12	0.022	50V	mylar	
C120, 220	1-105-522-12	0.056	50V	mylar	
C121, 221	1-105-519-12	0.033	50V	mylar	
C122, 222	1-105-523-12	0.068	50V	mylar	
C123, 223	1-121-398-11	10	25V	elect	
C124, 224	1-107-016-11	470	50V	silvered mica	
C301, 401	1-121-409-11	47	16V	elect	
C302, 402	1-121-398-11	10	25V	elect	
C303, 403	1-107-131-11	100p	50V	silvered mica	

<u>Ref. No.</u>	<u>Part No.</u>	<u>Description</u>		<u>Ref. No.</u>	<u>Part No.</u>	<u>Description</u>	
C304, 404	1-121-420-11	220	10 V elect	R102, 202	1-222-305-11	100 k (A)	variable
C305, 405	1-107-123-11	47p	50 V silvered mica (Canada, USA)			(LINE RECORD VOLUME)	
C306, 406	1-105-517-12	0.022	50 V mylar	R103, 203	1-242-663-11	390	
C307, 407	1-121-420-11	220	10 V elect	R104, 204	1-242-687-09	3.9 k	low noise
C308, 408	1-106-667-12	0.0033	50 V mylar	R105, 205	1-242-709-09	33 k	low noise
C309, 409	1-121-393-11	3.3	50 V elect	R106, 206	1-242-729-09	220 k	low noise
C310, 410	1-107-123-11	47p	50 V silvered mica	R107, 207	1-242-681-11	2.2 k	
C311, 411	1-105-661-12	0.001	50 V mylar	R108, 208	1-242-659-11	270	
C312, 412	1-121-393-11	3.3	50 V elect	R109, 209	1-242-697-09	10 k	low noise
C313, 413	1-107-123-11	47p	50 V silvered mica	R110, 210	1-222-306-11	20 k (A)	variable
C314, 414	1-121-409-11	47	16 V elect			(MIC RECORD VOLUME)	
C315, 415	1-121-395-11	4.7	25 V elect	R111, 211	1-244-679-11	1.8 k	
C316, 416	1-121-395-11	4.7	25 V elect	R112, 212	1-242-731-09	270 k	low noise
C317, 417	1-121-391-11	1	50 V elect	R113, 213	1-242-729-09	220 k	low noise
C318, 418	1-105-666-12	0.0027	50 V mylar	R114, 214	1-242-699-09	12 k	low noise
C419	1-105-845-12	0.1	50 V mylar	R115, 215	1-242-663-11	390	
C320, 420	1-105-661-12	0.001	50 V mylar	R116, 216	1-242-691-09	5.6 k	low noise
C501	1-107-008-11	150p	500 V silvered mica	R117, 217	1-242-693-11	6.8 k	
C502	1-107-008-11	150p	500 V silvered mica	R118, 218	1-242-717-09	68 k	low noise
C503	1-141-069-11	20 ~ 120p	trimmer	R119, 219	1-242-711-09	39 k	low noise
C504	1-141-069-11	20 ~ 120p	trimmer	R120, 220	1-242-725-09	150 k	low noise
C505	1-107-221-11	560p	1,500 V silvered mica	R121, 221	1-242-717-09	68 k	low noise
C506	1-105-719-12	0.033	100 V mylar	R122, 222	1-242-749-11	1.5 M	
C507	1-127-094-11	1	25 V solid aluminum elect	R123, 223	1-242-673-11	1 k	
C508	1-105-712-12	0.0082	100 V mylar	R124, 224	1-242-641-11	47	
C509	1-106-060-12	0.0012	100 V mylar (AEP, AUS, E)	R125, 225	1-242-687-09	3.9 k	low noise
C510	1-106-060-12	0.0012	100 V mylar (AEP, AUS, E)	R126, 226	1-242-687-11	3.9 k	
C601	1-121-388-11	1,000	35 V elect	R127, 227	1-242-697-11	10 k	
C602	1-121-405-11	33	50 V elect	R128, 228	1-222-774-11	10 k (B)	adjustable
C603	1-121-810-11	470	50 V elect			(record level adj)	
C604	1-121-396-11	4.7	50 V elect	R129, 229	1-242-665-11	470	
C701	1-107-175-11	180p	50 V silvered mica	R130, 230	1-242-707-11	27 k	
C702	1-107-175-11	180p	50 V silvered mica	R131, 231	1-242-721-11	100 k	
C703	1-107-131-11	100p	50 V silvered mica	R132, 232	1-242-721-11	100 k	
C704	1-107-131-11	100p	50 V silvered mica	R133, 233	1-242-673-11	1 k	
C705	1-107-131-11	100p	50 V silvered mica	R134, 234	1-242-681-11	2.2 k	
C706	1-105-759-12	0.033	200 V mylar	R135, 235	1-242-689-11	4.7 k	
C707	1-117-034-23	1.5	250 V metalized paper (Canada, USA)	R136, 236	1-242-689-11	4.7 k	
	1-117-036-22	1.5+0.5	250 V metalized paper (AEP, AUS, E)	R137, 237	1-242-635-11	27	
C708	1-107-131-11	100p	50 V silvered mica	R138, 238	1-242-689-11	4.7 k	
				R139, 239	1-242-645-11	68	
				R301, 401	1-242-705-09	22 k	low noise
				R302, 402	1-242-727-09	180 k	low noise
				R303, 403	1-242-693-09	68 k	low noise
				R304, 404	1-242-719-09	82 k	low noise
				R305, 405	1-242-721-11	100 k	
				R306, 406	1-242-713-11	47 k	
				R307, 407	1-242-727-09	180 k	low noise
				R308, 408	1-242-649-11	100	
				R309, 409	1-242-660-11	300	
				R310, 410	1-242-641-11	47	
				R311, 411	1-242-681-11	2.2 k	
				R312, 412	1-242-693-09	6.8 k	low noise

**RESISTORS**

All resistors are 1/4W, carbon type and in Ω unless otherwise noted.

R101, 201 1-244-719-11 82 k

<u>Ref. No.</u>	<u>Part No.</u>	<u>Description</u>
R313, 413	1-222-773-11	4.7 k (B) adjustable (PB EQ adj)
R314, 414	1-242-679-11	1.8 k
R315, 415	1-242-683-11	2.7 k
R316, 416	1-222-774-11	10 k (B) adjustable (PB EQ adj)
R317, 417	1-242-705-11	22 k
R318, 418	1-242-699-11	12 k
R319, 419	1-242-725-11	150 k
R320, 420	1-242-677-11	1.5 k
R321, 421	1-242-715-11	56 k
R322, 422	1-242-707-11	27 k
R323, 423	1-242-667-11	560
R324, 424	1-242-681-11	2.2 k
R325, 425	1-242-709-11	33 k
R326, 426	1-242-681-11	2.2 k
R327, 427	1-222-773-11	4.7 k (B) adjustable (level meter adj)
R328, 428	1-222-637-11	20 k (B) variable (LEVEL ADJUST)
R329, 429	1-242-681-11	2.2 k
R340, 440	1-242-685-11	3.3 k (AEP, AUS, E)
R501	1-242-617-11	4.7
R502	1-244-711-11	39 k
R503	1-244-625-11	10
R504	1-244-625-11	10
R505	1-242-643-11	56
R506	1-242-643-11	56
R601	1-202-549-31	100 (½) composition
R602	1-202-541-31	47 (½) composition
R603	1-242-711-11	39 k
R604	1-242-701-11	15 k
R605	1-242-675-11	1.2 k
R606	1-242-717-11	68 k
R701	1-244-685-11	3.3 k
R702	1-244-685-11	3.3 k
<b>SWITCHES</b>		
S101	1-514-644-00	rotary, equalizer; TAPE SPEED
S102	1-514-985-00	lever slide, TAPE SELECT
S103	1-514-640-00	lever slide, MONITOR(L-CHANNEL)
S104	1-514-640-00	lever slide, MONITOR(R-CHANNEL)
S105	1-514-861-22	slide, record/playback (L-CH)
S106	1-514-861-22	slide, record/playback (R-CH)
S107	1-514-643-00	rotary, muting

<u>Ref. No.</u>	<u>Part No.</u>	<u>Description</u>
S108	1-514-231-11	micro, bias osc
S109	1-514-655-31	seesaw, POWER (E)
	1-514-472-21	seesaw, POWER (AEP, AUS)
	1-514-655-71	seesaw, POWER (Canada, USA)
S110	1-514-039-12	micro, auto shut-off
S111	1-514-641-00	lever slide, MIC ATT
<b>JACKS</b>		
J101, 201	1-507-142-21	2-P phono, LINE IN
J102, 202	1-507-281-00	mini, MICROPHONE
J103, 203	1-507-142-21	2-P phono, LINE OUT
J104	1-507-282-00	binaural, HEADPHONE
CNJ101	1-509-359-11	connector, REC/PB (AEP, AUS, E)
CNJ102	1-509-445-11	connector 3-P, AC IN (AEP, AUS)
CN101	1-509-427-11	socket, power voltage selector (E)
	1-509-482-11	socket, power voltage selector (AEP, AUS)
<b>MISCELLANEOUS</b>		
M	8-832-624-22	motor, IC-624H1 (AEP, AUS, E, USA)
	8-832-624-27	motor, IC-624H1 (Canada)
CP701, CP702	1-101-534-12	encapsulated components, 0.1 μF + 120 Ω (AEP, AUS, E)
	1-101-534-31	encapsulated components, 0.1 μF + 120 Ω (Canada, USA)
RH101	8-825-511-00	head, record (RF140-2902)
PH103	8-825-534-00	head, playback (PF140-4202)
EH102	8-826-629-25	head, erase (EF18-2902A1)
PL1, 2	1-518-153-31	lamp, 5 V/60 mA
PL3	1-518-070-00	lamp, 8 V/0.3 A
	1-533-051-15	holder, lamp
ME1, 2	1-520-114-12	meter, level
F1	1-532-096-00	fuse, 800mA (E)
	1-532-080-11	fuse, 800mA (AEP, AUS)
F1, 2	1-532-262-11	fuse, 500mA (Canada)
F2	1-532-235-11	fuse, 315mA (AEP, AUS)
F3	1-532-235-11	fuse, 315mA (AEP, AUS)
	1-532-265-11	fuse, 1A (Canada)
F4	1-532-080-11	fuse, 800mA (AEP, AUS)
	1-533-006-00	holder, fuse (E)
	1-533-026-61	holder, fuse (AEP, AUS)
	1-582-015-21	holder, fuse (Canada)
	1-534-487-22	cord, ac power (E)
	1-534-538-21	cord, ac power (Canada, USA)
	1-535-506-11	solderless terminal
	1-536-395-11	terminal strip, 1-L-1 (C type)
	1-536-398-11	terminal strip, 2-L-2 (C type)
	1-506-312-13	terminal, joint
	1-507-323-13	terminal, joint

## SECTION 7 HARDWARE

<u>Part No.</u>	<u>Description</u>	<u>Part No.</u>	<u>Description</u>
<b>SCREWS</b>			
7-621-259-42	P 2.6 x 6	7-685-145-21	P 3 x 6, self-tapping
7-621-259-52	P 2.6 x 8	7-685-146-21	P 3 x 8, self-tapping
7-621-259-62	P 2.6 x 10	7-685-549-01	P 3 x 16
7-621-259-72	P 2.6 x 12	<b>WASHERS</b>	
7-621-560-52	K 2.6 x 22	7-623-105-12	2 mm dia
7-621-711-35	B 2.6 x 6	7-623-107-02	2.6 mm dia (small)
7-621-771-38	B 2.6 x 8	7-623-107-22	2.6 mm dia
7-628-145-01	P 3 x 4	7-623-108-02	3 mm dia (small)
7-628-147-01	P 3 x 6	7-623-108-12	3 mm dia (nickel plated)
7-628-148-01	P 3 x 8	7-623-108-18	3 mm dia (chrome plated)
7-628-149-01	P 3 x 10	7-623-108-20	3 mm dia
7-628-150-01	P 3 x 12	7-623-110-02	4 mm dia (small)
7-628-160-01	P 3 x 6	7-623-110-12	4 mm dia
7-628-161-01	P 4 x 8	7-623-113-12	6 mm dia
7-628-547-13	B 3 x 6	7-623-208-22	3 mm dia, spring
7-628-548-13	B 3 x 8	7-623-408-05	3 mm dia, external tooth
7-682-549-13	B 3 x 10	<b>NUTS</b>	
7-682-550-14	B 3 x 12	7-622-108-02	3 mm dia
7-682-551-15	B 3 x 4	7-622-501-06	4 mm dia
7-682-562-13	B 4 x 10	<b>RETAINING RINGS</b>	
7-682-571-14	B 4 x 45	7-624-104-01	E-2
7-682-624-00	PS 2 x 4	7-624-106-01	E-3
7-682-627-00	PS 2 x 8	7-624-108-01	E-4
7-682-633-00	PS 2.6 x 4	7-624-109-01	E-5
7-682-635-00	PS 2.6 x 6	7-624-110-01	E-6
7-682-637-00	PS 2.6 x 10	7-624-111-01	E-7
7-682-646-00	PS 3 x 5	7-624-112-01	E-8
7-682-647-00	PS 3 x 6		
7-682-648-00	PS 3 x 8		
7-682-652-00	PS 3 x 16		
7-682-660-00	PS 4 x 6		
7-682-661-00	PS 4 x 8		
7-683-140-01	⊖ SC 3 x 6, flat point		
7-683-242-31	SC 3 x 10		

**Note:** All screws are Phillips type (cross recess type) unless otherwise indicated.  
(-): slotted head

- Hardware Nomenclature -

<p><b>P</b> - Pan Head Screw </p> <p><b>PS</b> - Pan Head Screw with Spring Washer </p> <p><b>K</b> - Flat Countersunk Head Screw </p> <p><b>B</b> - Binding Head Screw </p> <p><b>RK</b> - Oval Countersunk Head Screw </p> <p><b>T</b> - Truss Head Screw </p> <p><b>R</b> - Round Head Screw </p> <p><b>F</b> - Flat Fillister Head Screw </p>	<p><b>SC</b> - Set Screw </p> <p><b>E</b> - Retaining Ring (E Washer) </p> <p style="margin-left: 20px;"><b>W</b> - Washer</p> <p style="margin-left: 20px;"><b>SW</b> - Spring Washer</p> <p style="margin-left: 20px;"><b>LW</b> - Lock Washer</p> <p style="margin-left: 20px;"><b>N</b> - Nut</p> <p><b>- Example -</b></p> <div style="margin-left: 20px;"> </div>
---------------------------------------------------------------------------------------------------------------------------------------------------------------------------------------------------------------------------------------------------------------------------------------------------------------------------------------------------	-------------------------------------------------------------------------------------------------------------------------------------------------------------------------------------------------------------------------------------------------------------------------------------------------------------------------------------------------------------------------