

GX-646

STEREO TAPE DECK

Notes:

- This manual is applicable to both silver and black panel models.
- Supply reel and tape shown in photograph not included in standard accessories.

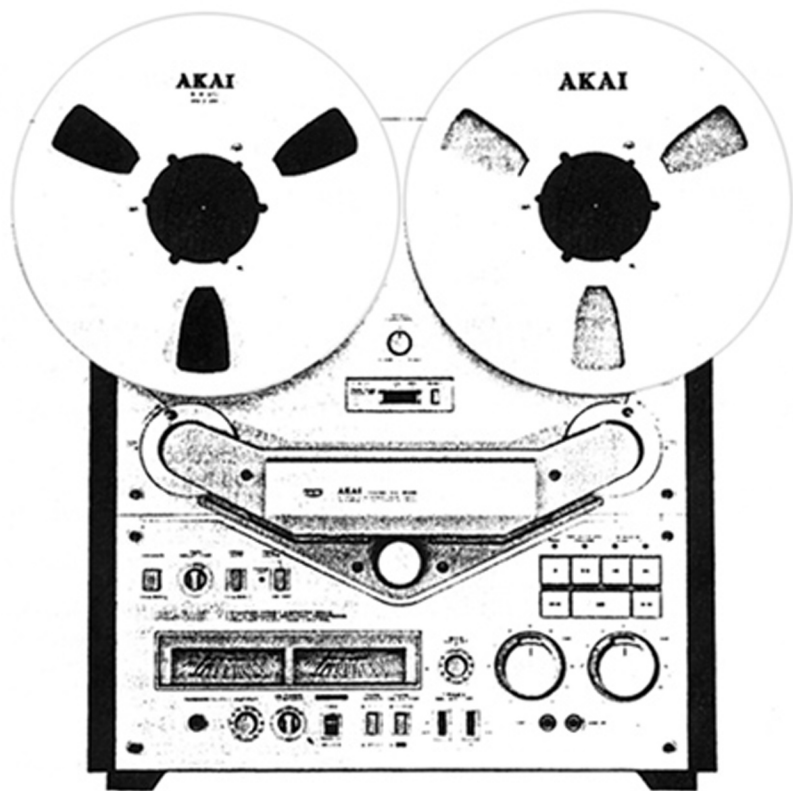

WARNING

To prevent fire or shock hazard, do not expose this appliance to rain or moisture.

Operator's Manual

AKAI

WARNING

POWER REQUIREMENTS

Power requirements for electrical equipments differ from area to area. Please ensure that your machine meets the power requirements in your area.

If in doubt, consult a qualified electrician.

120 V, 60 Hz for USA and Canada

220 V, 50 Hz for Europe except UK

240V, 50 Hz for UK and Australia

110V/120V/220V/240V, 50/60 Hz internally switchable for other countries.

VOLTAGE SELECTION

Do Not Attempt This Conversion Yourself.

Voltage conversion (Models for Canada, USA, Europe, UK and Australia are not equipped with this facility). Each machine is preset at the factory according to destination, but some machines can be set to 110V, 120V, 220V or 240V as required. If your machine's voltage can be converted, refer the following voltage conversion to a qualified Service Repair Shop or professional service personnel.

1. Disconnect the Power Cord.
2. Loosen holding screws and feet with a screwdriver and remove the back panel.
3. Remove the Voltage Selector plug and reinsert so that the proper area voltage shows through the plug cut-out.
4. Change only the F1 fuse on the Fuse P.C. Board to correspond with the voltage. Follow instruction near the Voltage Selector plug explicitly.
5. Set the Cycle Selector located on the right side of the Sys. Con. P.C. Board according to the power source frequency for your area.

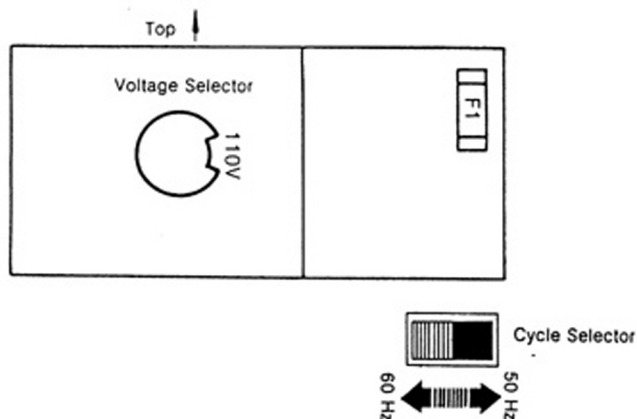

PRECAUTIONS



CAUTION

**RISK OF ELECTRIC SHOCK
DO NOT OPEN**



CAUTION: TO REDUCE THE RISK OF ELECTRIC SHOCK, DO NOT REMOVE COVER (OR BACK).

**NO USER-SERVICEABLE PARTS INSIDE.
REFER SERVICING TO QUALIFIED SERVICE PERSONNEL.**



The lightning flash with arrowhead symbol superimposed across a graphical representation of a person, within an equilateral triangle, is intended to alert the user of the presence of uninsulated "dangerous voltage" within the product's enclosure; that may be of sufficient magnitude to constitute a risk of electric shock to persons.

- The exclamation point within an equilateral triangle is intended to alert the user of the presence of important operating and maintenance (servicing) instructions in the literature accompanying the appliance.

1. Use only household AC power sources. Never use DC power sources.
2. Touching the plug with wet hands risks dangerous electric shocks. Always pull out by the plug and never the cord.
3. Make sure the power consumption of each audio component does not exceed wattage specified on the rear panel. Only connect other audio components.
4. Only let a qualified professional repair or reassemble the equipment. An unauthorized person might touch the internal parts and receive a serious electric shock.
5. Never allow a child to put anything, especially metal into this equipment. A serious shock or malfunction may occur.
6. If water is spilled on this equipment, disconnect and call your dealer.
7. Make sure the equipment is well ventilated and away from direct sunlight.
8. Keep away from heat (stoves, etc.) to avoid damage to the external surface and internal circuits.
9. Avoid spray-type insecticides which will damage the equipment and may ignite suddenly.
10. To avoid damaging the finish never use paint thinner or other similar chemicals.
11. Always place the equipment on a flat and solid surface.
12. As the deck is quite heavy please be careful when handling the deck.
13. Please read this manual in its entirety and keep it handy for further reference.

This equipment conforms to No. 76/889/EEC standard.

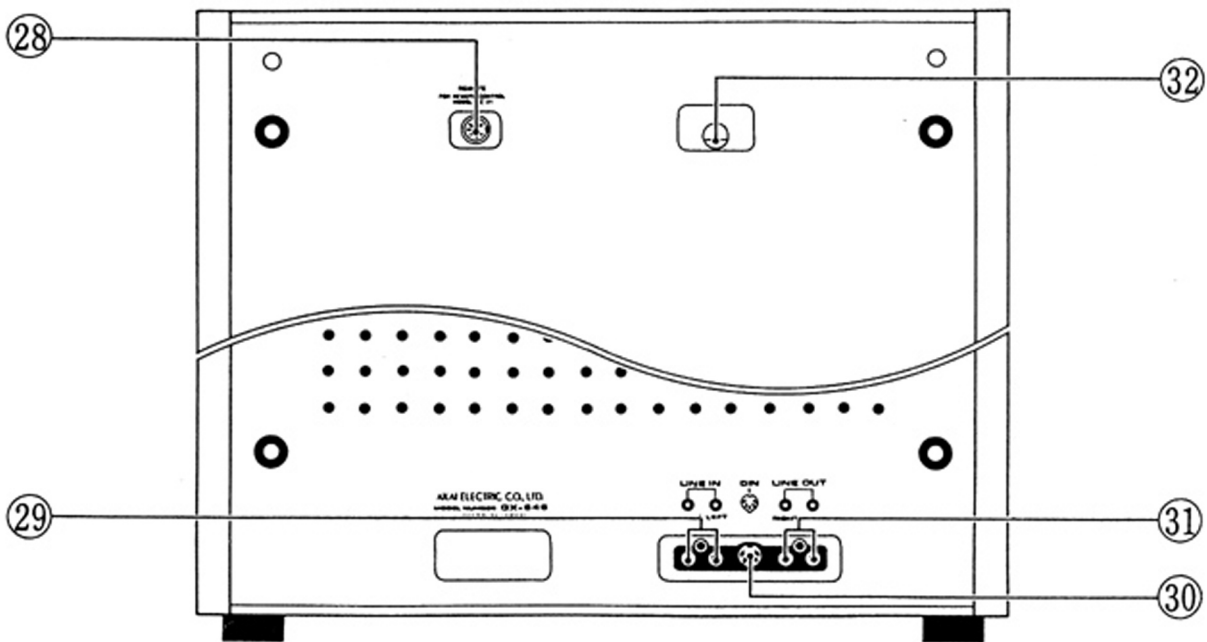
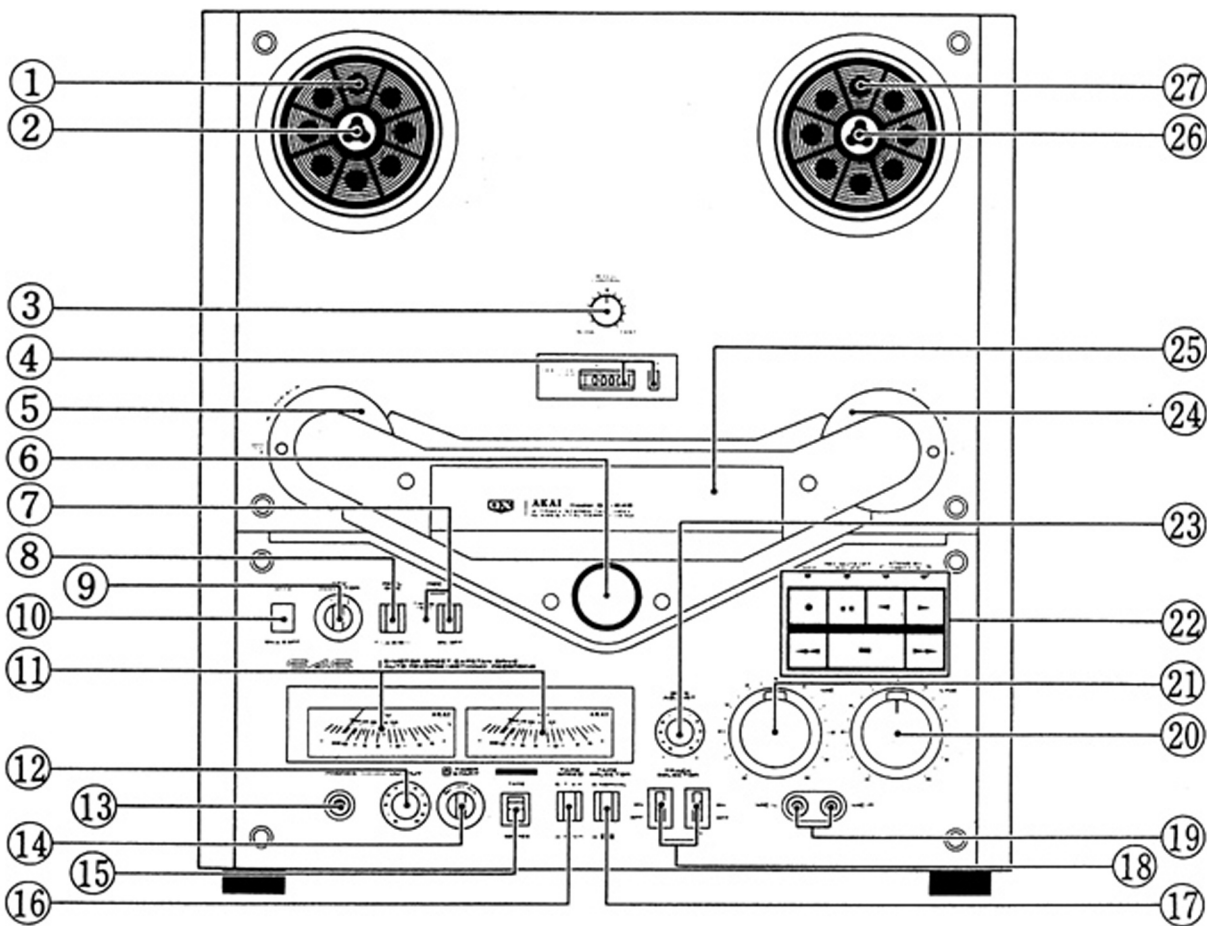

CONTROLS

- Supply Reel Table**
- Built-in Reel Retainer (left)**

To lock the reel firmly into place, pull the tip of the Retainer outward and turn to the left or right.
- PITCH CONTROL (SLOW/FAST)**

Facilitates modification of playback musical tone as desired by changing the musical interval by ± 1 semi-tone (tape speed $\pm 6\%$). Convenient for musical instruction or adjusting pitch during duet performance, etc.

 - This control is effective only during playback and must be kept at center click position during recording.
- REAL TIME COUNTER and RESET Button**

Indicates for the tape speed of 7-1/2 in (19 cm/sec). Convenient for locating particular places on the tape and for keeping time at playback and recording. Depress the RESET button to reset the REAL TIME COUNTER to "0000".
- Left Tension Arm (Forward, Reverse Sensing Pole)**

Provides ideal tape tension for a smooth tape travel. It is interlocked with automatic stop and starts the motor only when the tape is given correct tension. Lock the Arm to the ARM LOCK position when loading a tape, then release to STAND BY position when loading has been completed.

 - The motor will not start with arm at ARM LOCK position.
- Pinch Roller**

Presses against the capstan to transport the tape.
- Recording (REC) MUTE Switch and TIMING 1 SEC Indicator**

When this switch is depressed, the recording amp circuit will be brought into a no-signal mode. No recording will be made on the tape during this period. The TIMING 1 SEC indicator will flash on and off at approximately one second interval to allow timing of blank portion. To release the REC MUTE, depress the button again or depress the Pause (|||) button to put the deck into recording standby.

 - Set the MONITOR selector to SOURCE during this period.
- REEL SIZE Selector**

10: Set to this position when using 10-1/2 inch (26 cm) reels.
7: Set to this position when using 7 (17 cm) or 5 (12 cm) inch reels.
- Reverse (REV) SELECTOR**

—: Set to this position for one-way (forward or reverse) recording or playback.
⇄: Set to this position for one cycle (forward to reverse) recording or playback.
∞: Set to this position for continuous playback. Playback will continue until the Stop (■) button is depressed. Recording will take place as in ⇄ mode.

 - Automatic stop will be effected at the end of reverse recording.
- POWER Switch**
- Left and Right VU Meters**

Indicate the left and right channel recording and playback levels.
- OUTPUT Control**

Adjusts line or headphone output levels during playback. Set to correspond with the external amplifier input.

 - Not interconnect with the VU Meters.
 - Refer to HOW TO USE OUTPUT CONTROL DURING RECORDING AND PLAYBACK on page 11.
- Headphone Jack (PHONES)**

Accommodates 8 ohm impedance type stereo headphones.
- MONITOR Selector**

TAPE: Set to this position to monitor the just recorded signals.
Set to this position during playback.
SOURCE: Set to this position to monitor the source signals.
The just recorded signals can be compared with the source signals by switching to and from TAPE and SOURCE positions during recording.
For accurate monitoring, match the line output level of the deck with the line listening level of the external amplifier. Refer to HOW TO USE OUTPUT CONTROL DURING RECORDING AND PLAYBACK on page 11.
- TIMER START Switch**

REC: For absentee recording
OFF: For all other times when timer start operation is not to be engaged.
PLAY: For timed playback
- TAPE SPEED Selector**

7-1/2 in: Set to this position for 7-1/2 inches per second (19 cm/sec) tape speed.
3-3/4 in: Set to this position for 3-3/4 ips (9.5 cm/sec) tape speed.
Refer to TAPE RECORDING TIME on page 6.
- TAPE SELECTOR**

NORMAL: Set to this position when using low noise or wide range tape.
EE: Set to this position when using extra efficiency tape.
Refer to STANDARD REFERENCE AND RECOMMENDED TAPES on page 6.
- TRACK SELECTORS (L: left, R: right)**

L: Set to ON for monaural recording on tracks 1 — 4.
R: Set to ON for monaural recording on tracks 3 — 2.
Set both SELECTORS to ON for stereo recording.
- Microphone Jacks (MIC L: left, R: right)**

Plug in a microphone (s) for microphone recording.
- LINE Recording Level Controls and Memory Marker (L: left ⇄ R: right)**

Adjust recording input levels for line input. The outer ring controls the right channel recording input level and the inner knob controls the left channel recording input level. The controls are coaxial therefore they may be adjusted independently or together.

 - Coaxial controls and enumerated positions facilitate easy fade-in (gradual increase in volume at the beginning of a musical selection) and fade-out (gradual decrease in volume at the end) recording operation. Set the Memory Marker to the optimum recording level to regain the optimum recording level for fade-in or for effective fade-out operations. The Memory Marker will move with the other two controls if enough pressure is applied.
- Microphone Recording Level Controls with Memory Marker (MIC L: left ⇄ R: right)**

Adjust recording input level for microphone input. The outer ring controls the right channel recording input level and the inner knob controls the left recording input level. The controls are coaxial, therefore they may be adjusted independently or together.

 - Refer to above for fade-in, fade-out operation and for use of Memory Marker.
 - This control also controls the DIN input level if the model is equipped with a DIN jack.
- Operating Buttons**

Recording (●) Button and Indicator
Depress the Recording (●) and Forward (▶) buttons simultaneously for forward recording, and Recording (●) and Reverse (◀) buttons simultaneously for reverse recording.
The REC indicator will light to confirm recording mode.

Pause (|||) Button and Indicator
Depress this button to temporarily suspend tape travel during recording or playback. Depress this button to release the REC MUTE and the deck will go into recording standby. Depress again to recommence tape travel.

 - The Pause (|||) button does not function during fast forward or rewind.
 - During recording, set the MONITOR selector to SOURCE before depressing the Pause (|||) button.
 - The PAUSE indicator will light to confirm pause mode.

Reverse (◀) Button and Indicator
Depress this button for reverse recording or playback.
The indicator will light to confirm direction.

Forward (▶) Button and Indicator
Depress this button for forward recording or playback.
The indicator will light to confirm direction.

 - When the power is switched on again after being switched off once during the reverse mode, the direction of tape travel will automatically change to Forward.

Rewind (◀◀) Button
Depress to rewind the tape in the direction of arrow.

Stop (■) Button
Depress to stop tape travel and to cancel recording, playback, fast forward, rewind and pause modes.

Fast Forward (▶▶) Button
Depress to fast forward the tape in the direction of arrow.
- BIAS ADJUST Control**

Adjust within $\pm 30\%$ the recording bias according to type of tape used.
Refer to BIAS ADJUSTMENT on page 6.
- Right Tension Arm (Forward, Reverse Sensing Pole)**
- Head Cover**
- Built-in Reel Retainer (right)**
- Take-up Reel Table**
- REMOTE Control Jack**

Connect the optional Remote Control Unit RC-90 or RC-21 for remote control operation.

 - Use only an Akai recommended connection cord.
- LINE IN Jacks (RIGHT and LEFT)**

Connect to the output jacks of an external amplifier (REC jacks) or tape deck or recorder (LINE OUT jacks).
- DIN Jack (Some models do not have this facility.)**

Can be used instead of the LINE IN and OUT jacks for connection with an external amplifier through a DIN connection cord.
- LINE OUT Jacks (RIGHT and LEFT)**

Connect to the input jacks of an external amplifier (PLAY jacks) or tape deck or recorder (LINE IN jacks).
- AC Power Cord**

FOR CUSTOMERS IN THE UK

IMPORTANT FOR YOUR SAFETY
The flex supplied with your machine will have either two wires or three as shown in the illustrations.

THREE CORE FLEX WARNING

THIS APPARATUS MUST BE EARTHED IMPORTANT

The wires in this mains lead are coloured in accordance with the following code:

- Green-and-yellow: Earth
- Blue: Neutral
- Brown: Live

As the colours of the wires in the mains lead of this apparatus may not correspond with the coloured markings identifying the terminals in your plug, proceed as follows:

The wire which is coloured green-and-yellow must be connected to the terminal in the plug which is marked by the letter E or by the safety earth symbol \perp or coloured green or coloured green-and-yellow.

The wire which is coloured blue must be connected to the terminal which is marked with the letter N or coloured black.

The wire which is coloured brown must be connected to the terminal which is marked with the letter L or coloured red.

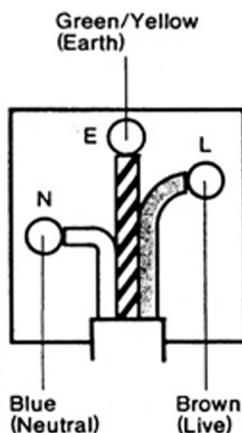

TWO CORE FLEX IMPORTANT

The wires in this mains lead are coloured in accordance with the following code:

- Blue: Neutral
- Brown: Live

As the colours of the wires in the mains lead of this apparatus may not correspond with the coloured markings identifying the terminals in your plug, proceed as follows:

The wire which is coloured blue must be connected to the terminal which is marked with the letter N or coloured black.

The wire which is coloured brown must be connected to the terminal which is marked with the letter L or coloured red.

* Do not connect any wire to the larger pin marked E or \perp when wiring a plug. Ensure that all terminals are securely tightened and that no loose strands of wire exist.

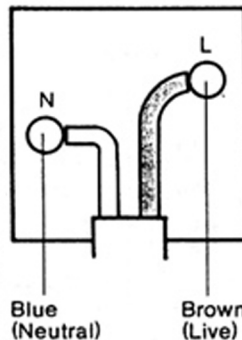

FOR CUSTOMERS IN AUSTRALIA

If your machine comes with a three core power cord, FOR YOUR SAFETY.

1. Insert this plug only into an effectively earthed three-pin plug socket outlet.
2. If any doubt exists regarding the earthing, consult a qualified electrician.
3. Extension cords, if used, must be three core correctly wired.

FOR CUSTOMERS IN THE U.S.A.

SAFETY INSTRUCTIONS

1. **Read Instructions** — All the safety and operating instructions should be read before the equipment is operated.
2. **Retain Instructions** — The safety and operating instructions should be retained for future reference.
3. **Heed Warnings** — All warnings on the equipment and in the operating instructions should be adhered to.
4. **Follow Instructions** — All instructions for operating and use should be followed.
5. **Water and Moisture** — The equipment should not be used near water — for example, near a bathtub, washbowl, kitchen sink, laundry tub, in a wet basement, or near a swimming pool, etc.
6. **Carts and Stands** — The equipment should be used only with a cart or stand that is recommended by Akai.
7. **Wall or Ceiling Mounting** — Akai does not recommend mounting the equipment on a wall or a ceiling.
8. **Ventilation** — The equipment should be situated so that its location or position does not interfere with its proper ventilation. For example, the equipment should not be situated on a bed, sofa, rug, or similar surface that may block the ventilation openings; or, placed in a built-in installation, such as a bookcase or cabinet that may impede the flow of air through the ventilation openings.
9. **Heat** — The equipment should be situated away from heat sources such as radiators, heat registers, stoves, or other equipments (including amplifiers) that produce heat.
10. **Power Sources** — The equipment should be connected to a power supply only of the type described in the operating instructions or as marked on the equipment.
11. **Grounding or Polarization** — The precautions should be taken so that the grounding or polarization means of an equipment is not defeated.
12. **Power-Cord Protection** — Power-supply cords should be routed so that they are not likely to be walked on or pinched by items placed upon or against them, paying particular attention to cords at plugs, convenience receptacles, and the point where they exit from the equipment.
13. **Cleaning** — The equipment should be cleaned only as recommended by the manufacturer.
14. **Power Lines** — An outdoor antenna should be located away from power lines.
15. **Outdoor Antenna Grounding** — If an outside antenna is connected to the receiver, be sure the antenna system is grounded so as to provide some protection against voltage surges and built up static charges. Section 810 of the National Electrical Code, ANSI/NFPA No. 70—1981, provides information with respect to proper grounding of the mast and supporting structure, grounding of the lead-in wire to an antenna discharge unit, size of grounding conductors, location of antenna-discharge unit, connection to grounding electrodes, and requirements for the grounding electrode. See Figure 1.
16. **Nonuse Periods** — The power cord of the equipment should be unplugged from the outlet when left unused for a long period of time.
17. **Object and Liquid Entry** — Care should be taken so that objects do not fall and liquids are not spilled into the enclosure through openings.
18. **Damage Requiring Service** — The equipment should be serviced by qualified service personnel when:
 - A. The power-supply cord or the plug has been damaged; or
 - B. Objects have fallen, or liquid has been spilled into the equipment; or
 - C. The equipment has been exposed to rain; or
 - D. The equipment does not appear to operate normally or exhibits a marked change in performance; or
 - E. The equipment has been dropped, or the enclosure damaged.
19. **Servicing** — The user should not attempt to service the equipment beyond that described in the operating instructions. All other servicing should be referred to qualified service personnel.

Figure 1
Example of Antenna Grounding as
per National Electrical Code Instructions

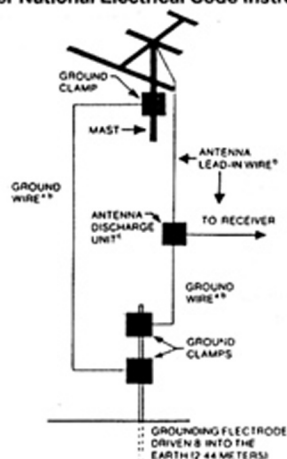

- a Use No. 10 AWG (5.3 mm²) copper, No. 8 AWG (8.4 mm²) aluminum, No. 17 AWG (1.0 mm²) copper-clad steel or bronze wire, or larger, as ground wire.
- b Secure antenna lead-in and ground wires to house with stand-off insulators spaced from 4 feet (1.22 m) to 6 feet (1.83 m) apart.
- c Mount antenna discharge unit as close as possible to where lead-in enters house.

CONNECTIONS

FOR RECORDING AND PLAYBACK

(Some models are not equipped with a DIN jack.)

- Turn off all the components before connecting.
- When a microphone is connected, DIN input is cut.

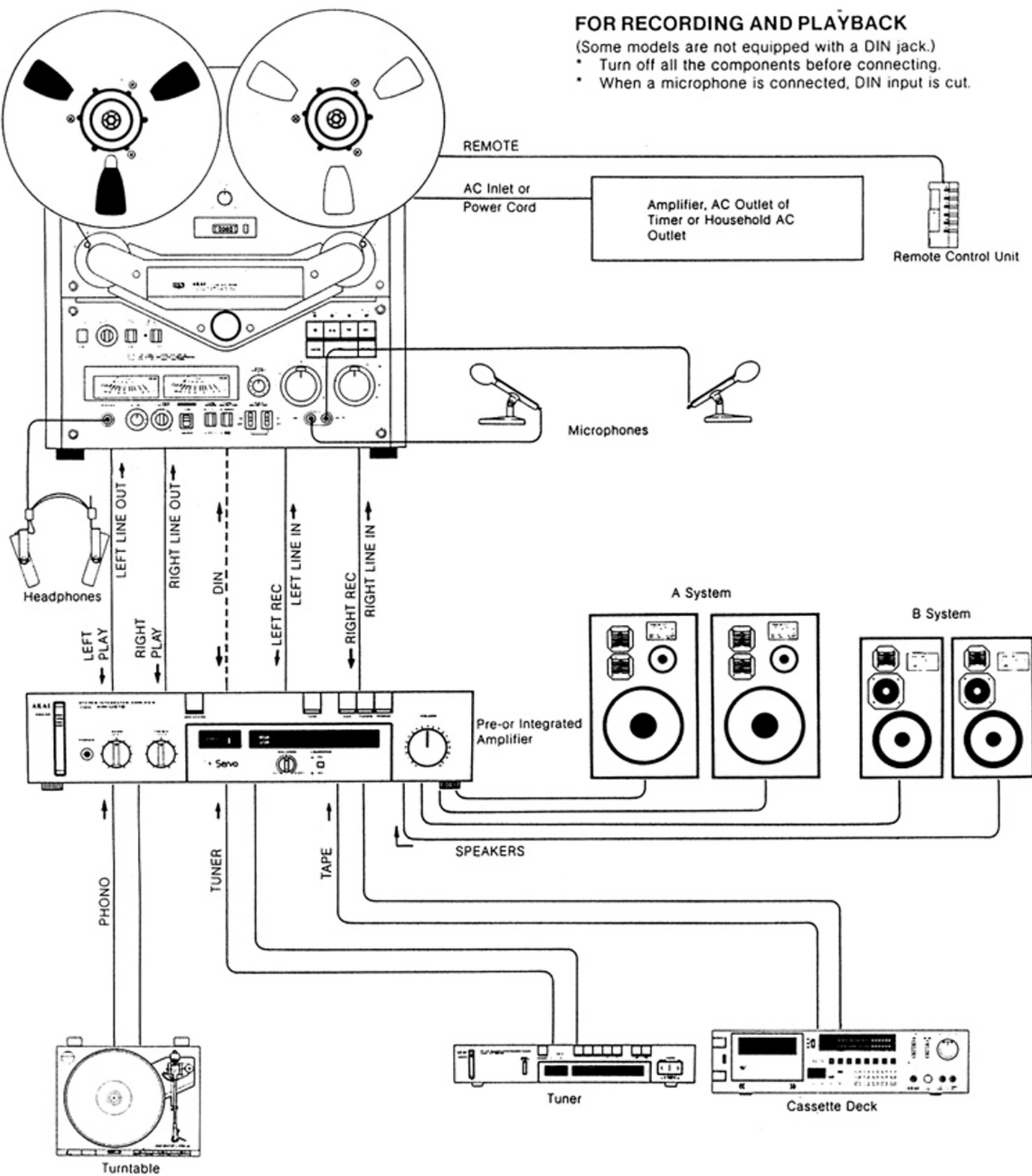

TAPE CARE

- Maxell UD (for NORMAL position) tapes are considered standard for this deck. The use of regular tape is not recommended.
- Set the TAPE SELECTOR to EE position only when using extra efficiency tape of a grade higher than normal tape.
- As tapes which have not been used for a period of time may have become sticky, run the tape once before using.
- Heads should be kept clean and demagnetized at all times.
- Recording cannot be made on the leader tape. Therefore, when using a new tape, be sure to forward the tape so that the leader tape is not in the head path.
- Tapes which have been stored in a hot moist place for a period of time or tapes with bent reel should not be used. Such tapes may curl or have greasy places altering tape speed and preventing proper

STANDARD REFERENCE AND RECOMMENDED TAPES

- The equalizer circuit adjusts according to the magnetic characteristics of the tape in use and it is therefore important to set the TAPE SELECTOR to the correct position.



This deck can be set for EE tapes. When using EE tapes, set the TAPE SELECTOR to the EE position and during recording set the BIAS ADJUST control to "0".

TAPE SELECTOR BRAND	NORMAL	EE
AKAI	LN, WR	
SCOTCH	#176, #177, #206, #207, #211, #212, #213, #218, #250, #1500, #2000, CL	
SONY	ULH, DUAD, PR-150, SLH, SLH-BL, FeCr	
TDK	GX, LX, T, AUDUAL, AUDUA, LB	SA*
MAXELL	LN, UD*, XL, UDXL	XL II*
BASF	LH, LN, LHS	
DENON	DX	
FUJI	FM, FG, FB	

- 150% type (550 m) tapes with this mark are the standard reference tapes.
- Each tape position is set according to the standard reference tape.

TAPE RECORDING TIME

Marketed tapes are of various lengths including those of 1,100m (3,600 ft.) 740m (2,400 ft.), 550m (1,800 ft.) and 370m (1,200 ft.). Since this machine offers two choices of tape speed, 7-1/2 ips (19

4-TRACK 2 CHANNEL STEREO RECORDING (PLAYBACK) SYSTEM

Tape Length		1,100m (3,600ft)	740m (2,400ft)	550m (1,800ft)
Tape Speed	7-1/2 in (19 cm/sec)	90 min.	60 min.	45 min.
	3-3/4 in (9.5 cm/sec)	180 min.	120 min.	90 min.
One-way		180 min.	240 min.	180 min.
Two-way		360 min.	240 min.	180 min.

- performance. Always store the tapes in a cool dry place.
- Do not touch the inner part of the tape with your fingers as signal drop-out will occur.
- Full care must be taken when handling thin tapes (200% and above: e.g., when tapes of 2,400 ft (740 m) length is used with 7 inch reels).
- Long-period storage of tapes that was taken up in a fast forward or rewind mode will cause damage to the tape, leading to unexpected troubles or will make them unfit for use. Therefore, the tapes should be stored in a condition as taken up in an orderly manner with the tape traveling at the fixed speed of recording or playback. However, either rewind or fast forward the entire tape before using the tape after storage.

BIAS ADJUSTMENT

- This deck is equipped with a BIAS Adjustment (ADJUST) control which can adjust the bias by $\pm 30\%$ at each tape position.
- When recording with standard reference tapes, set to "0".
- When recording with tapes not included in the list, set to "0".
- When recording with EE tapes, set to "0".
- When set to the most extreme right or left position, changes in frequency characteristics will occur.

BRAND	TAPE	Position	BRAND	TAPE	Position	
AKAI	WR 150	0	Scotch	#212	-1.5	
MAXELL	XL II (☐): REFERENCE)	0		#213	-4.5	
	UD (REFERENCE)	0		#206	-2.0	
	XL 35-90B	0		#250	+0.5	
TDK	SA (☐): REFERENCE)	0		#176	-2.0	
	GX35-90B	0		#1500	+0.5	
	LX35-90	0		#2000	-2.0	
SONY	ULH7-550	0		#177	-1.5	
DENON	DX-550	-2.0				

cm/sec) and 3-3/4 ips (9.5 cm/sec), by the TAPE SPEED selector, please refer to the following list for the recording time.

4-TRACK MONAURAL RECORDING (PLAYBACK) SYSTEM

Tape Length		1,100m (3,600ft)	740m (2,400ft)	550m (1,800)
Tape Speed	7-1/2 in (19 cm/sec)	90 min.	60 min.	45 min.
	3-3/4 in (9.5 cm/sec)	180 min.	120 min.	90 min.
One-way		180 min.	240 min.	180 min.
Two-way		360 min.	240 min.	180 min.
Two-way+ one-way		540 min.	360 min.	270 min.
Double two-way		720 min.	480 min.	360 min.

4-TRACK STEREO RECORD / PLAYBACK SYSTEM

Stereo recording requires the simultaneous use of two tracks. For stereo recording, set both the TRACK SELECTORS to ON (▲). The first stereo recording takes place on tracks 1 and 3, and the second on tracks 2 and 4 after the Reverse (◀) button has been engaged in the recording mode. For stereo playback, set both the TRACK SELECTORS to ON. The first stereo playback takes place on tracks 1 and 3, and the second on tracks 2 and 4 after the Reverse (◀) button has been engaged in the playback mode.

STEREO

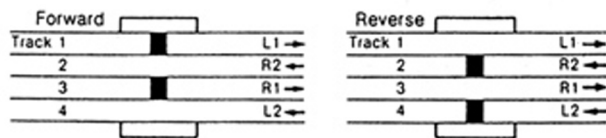

4-TRACK MONAURAL PLAYBACK SYSTEM

4-track monaural recording sequence is 1-4-3-2. For monaural operation, set the left (L) TRACK SELECTOR to ON (▲). The first recording takes place on track 1 and second on track 4 after the Reverse (◀) button has been engaged in the recording mode. For recording on tracks 3 and 2, set the right (R) TRACK SELECTOR to ON. The third recording takes place on tracks 3, and the fourth on track 2 after the Reverse (◀) button has been engaged in the recording mode. For monaural playback, set the TRACK SELECTORS to the position they were set during recording.

MONAURAL

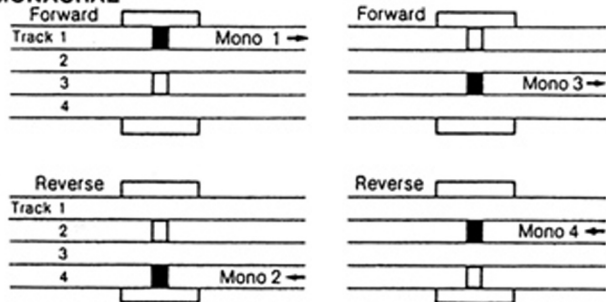

PREPARATION FOR AUTOMATIC REVERSE

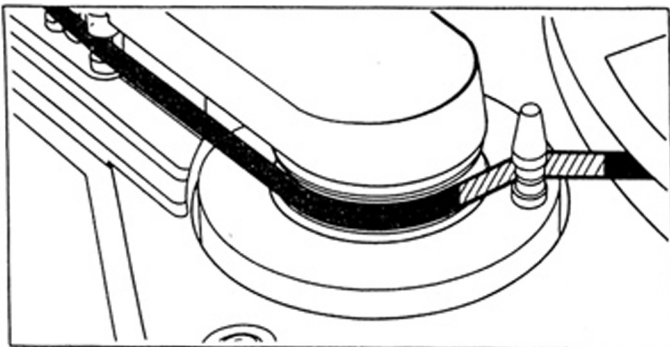

To change the direction of tape travel automatically, the following operations must be carried out:

One cycle forward or reverse recording or playback

Attach a 2.5 cm to 4 cm length of standard accessory Sensing Tape to the non-recording surface of the tape at a point where the direction is to be reversed. When the Sensing Tape comes in contact with the Left Tension Arm which also acts as a Sensing Pole, the direction of tape travel will automatically change.

Continuous playback

Attach two pieces of Sensing Tapes 2.5 cm to 4 cm in length to the non-recording surface of the tape at two points: two points at which playback is to be repeated. When the Sensing Tape comes in contact with the Left or Right Tension Arm, the direction of tape travel will automatically change.

TAPE LOADING

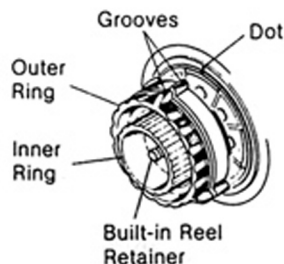

Using 7 or 5 inch reels

1. Place a full reel of tape on the Supply Reel Table and an empty reel of the same size on the Take-up Reel Table.
 2. Lock both reels into place by pulling the tip of Built-in Reel Retainers outward and turning to left or right to lock the reels.
 3. Set the Tension Arms to the ARM LOCK position.
 4. Unwind about an 85 cm length of tape from the Supply Reel and thread the tape as shown by the dotted line.
 5. Insert the end of tape in the slot of empty reel and wind around the reel hub two or three times.
 6. Continue winding the tape onto the Take-up Reel until all slack has been taken up.
 7. Release the Tension Arms inward to the STAND BY position when loading has been completed.
- * The motor will not start with arm at ARM LOCK position or if there is not enough tension.





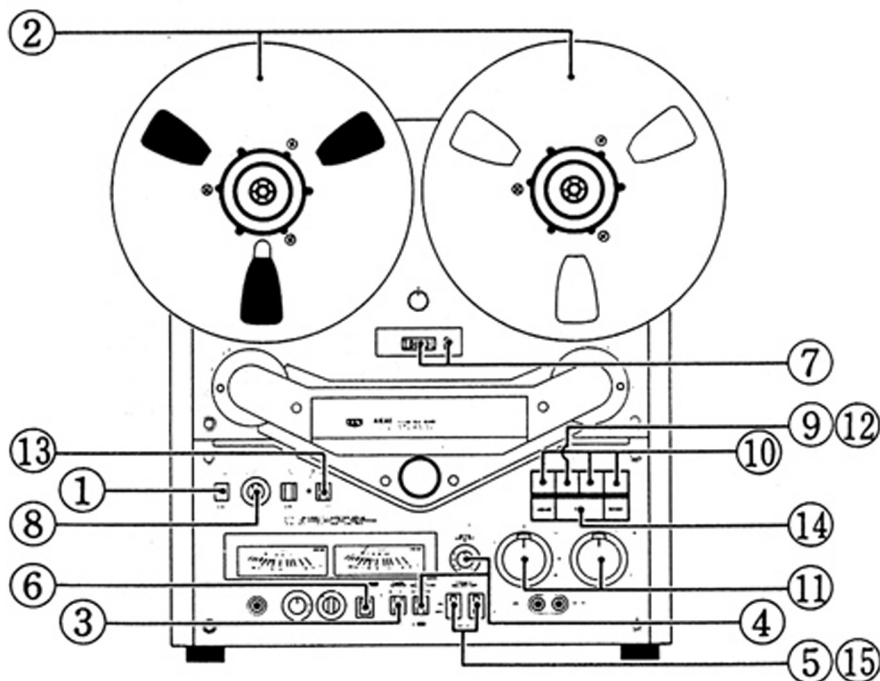

Using 10-1/2 inch reels







1. Place the standard accessory Reel Adapter Hubs on the Reel Table.
2. Plastic Reels: Align the grooves on the Hub with the dot on the Reel Table.
Metallic Reels: Align the grooves but do not align them with the dot.
3. Pull out the Built-in Reel Retainers and turn to left or right to lock.
4. Turn the Inner Rings clockwise to lock.
5. Fit the reels on the Hubs.
6. Turn the Outer Rings clockwise to lock.
7. Follow steps 3 to 7 of "Using 7 or 5 inch reels".



Confirm the following before attempting recording operation:

- Components are properly connected. Refer to CONNECTIONS FOR RECORDING AND PLAYBACK on page 5.
- The TIMER START switch is at the OFF position.
- The Power Cord is properly connected.
- The REEL SIZE selector is set to the proper position. Refer to CONTROLS No. 8 on page 3.
- The PITCH CONTROL is set to the center click position.

1. Turn on all the external components and depress the POWER switch to turn on the deck.
2. Load the tape. Refer to TAPE LOADING on page 7.
3. Set the TAPE SPEED selector to the desired speed. Refer to TAPE RECORDING TIME on page 6.
4. Set the TAPE SELECTOR and the BIAS ADJUST. Refer to STANDARD REFERENCE AND RECOMMENDED TAPES and BIAS ADJUSTMENT on page 6.
5. For stereo recording: Set both the TRACK SELECTORS to ON ().
For monaural recording: Set only the left (L) TRACK SELECTOR to ON for monaural recording on tracks 1-4.
* Refer to 4-TRACK STEREO RECORDING AND PLAYBACK SYSTEM and 4-TRACK MONAURAL RECORDING AND PLAYBACK SYSTEM on page 7.
6. Set the MONITOR selector to SOURCE.
7. Depress the RESET button and reset the REAL TIME COUNTER to "0000".
8. Set the Reverse (REV) SELECTOR. Refer to REVERSE SELECTOR on page 10.
9. Depress the Pause () button.
10. Depress the Recording () and Forward () buttons simultaneously for forward recording and the Recording () and Reverse () buttons simultaneously for reverse recording.
11. While observing the VU Meters, adjust the MIC or LINE Recording Level controls. Adjust so that the VU levels exceeds only by little the 0 VU. Refer to CONTROLS Nos. 20 and 21.

12. When the optimum recording levels have been determined, depress the Pause () button to begin recording.
 - * The just recorded signals can be compared with the source signals by switching the MONITOR selector to and from TAPE and SOURCE. When monitoring through speakers, the amplifier's Tape Monitor switch must be set to TAPE.
 - * For accurate monitoring, match the line output level of the deck with the playback level of the external amplifier. Refer to HOW TO USE OUTPUT CONTROL DURING RECORDING AND PLAYBACK on page 11.
13. Depress the REC MUTE switch for tape editing. Refer to CONTROLS No. 7.
 - * Set the MONITOR selector to SOURCE first.
14. To release recording mode, depress the Stop () button.
15. Monaural recording: Set only the right (R) TRACK SELECTOR to ON for recording on track 3-2.
Repeat steps 6 to 14.
 - * To manually change the direction of tape travel, depress the direction button (Forward or Reverse) opposite to the direction in which the tape is now traveling.
 - * To momentarily suspend tape travel, depress the Pause () button. The Pause () button does not function during fast forward or rewind.
 - * Depress the Rewind () button to rewind the tape in the direction of arrow.
 - * Depress the Fast Forward () button to fast forward the tape in the direction of arrow.
 - * To stop tape travel, depress the Stop () button.
 - * Automatic stop will be effected at the end of the tape.

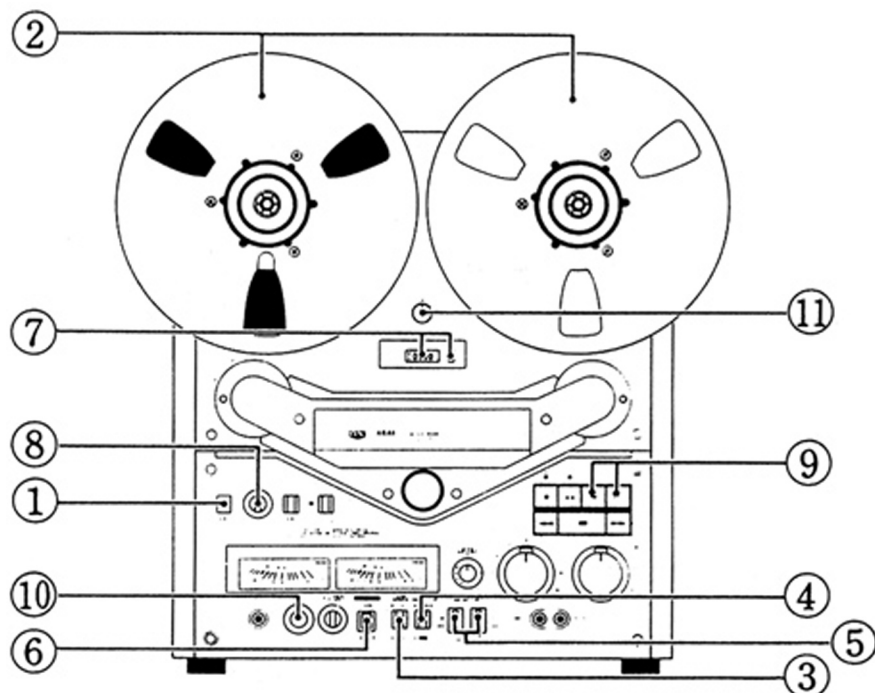

Confirm the following before attempting operation:

- Components are properly connected. Refer to CONNECTIONS FOR RECORDING AND PLAYBACK on page 5.
- Set the TRACK SELECTORS to the position they were set during recording.
- The TIMER START switch is at the OFF position.
- The Power Cord is properly connected.
- The REEL SIZE selector is set to the proper position. Refer to CONTROLS No. 8 on page 3.
- The PITCH CONTROL is set to the center click position.

1. Turn on all the external components and depress the POWER switch to turn on the deck.
2. Load the tape. Refer to TAPE LOADING on page 7.
3. Set the TAPE SPEED selector to the speed at which the tape was recorded.
4. Set the TAPE SELECTOR. Refer to STANDARD REFERENCE AND RECOMMENDED TAPES on page 6.
5. For stereo playback: Set both the TRACK SELECTORS to ON ().
For monaural playback: Set only the (L) TRACK SELECTOR to ON for playback of Tracks 1→4.
Set only the (R) TRACK SELECTOR to ON for playback of Tracks 3→2.
6. Set the MONITOR selector to TAPE.
 - Set the amplifier's Tape Monitor selector to TAPE when listening through speakers.
7. Depress the RESET button and reset the REAL TIME COUNTER to "0000".
8. Set the Reverse (REV) SELECTOR. Refer to REVERSE SELECTOR on page 10.
9. Depress the Forward () or Reverse () button depending on the desired direction of tape travel.
 - Indicator will light to confirm direction.

10. Adjust the OUTPUT control to adjust the headphone or line output level.
 - When listening through speakers, adjust the Output control of the amplifier. Refer to HOW TO USE OUTPUT CONTROL DURING RECORDING AND PLAYBACK on page 11.
 - This deck plays back only in stereo. Therefore when playing back tapes recorded in monaural, set the amplifier's Mode selector to Left or Right. If the amplifier does not have a Mode selector with Left and Right positions, set the Balance control so that only one channel is heard.
11. Adjust the PITCH CONTROL if desired. Refer to CONTROLS No. 3.
 - To manually change the direction of tape travel, depress the direction button (Forward or Reverse) opposite to the direction in which the tape is now traveling.
 - To momentarily suspend tape travel, depress the Pause () button. The Pause () button does not function during fast forward or rewind.
 - Depress the Rewind () button to rewind the tape in the direction of arrow.
 - Depress the Fast Forward () button to fast forward the tape in the direction of arrow.
 - To stop tape travel, depress the Stop () button.
 - Automatic stop will be effected at the end of the tape.

REVERSE SELECTOR
RECORDING
PLAYBACK
ONE WAY

One way forward recording

One way forward playback

**REV
SELECTOR**

One way reverse recording

One way reverse playback

ONE CYCLE

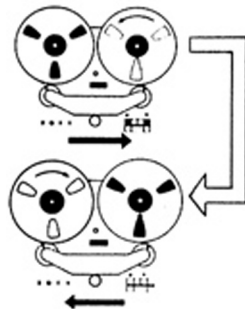
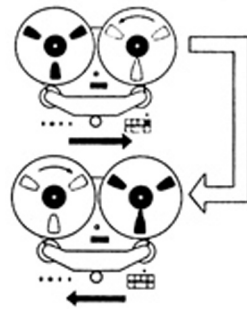
One cycle forward recording

One cycle forward playback

**REV
SELECTOR**

One way reverse recording

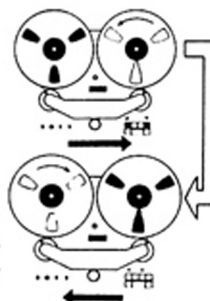
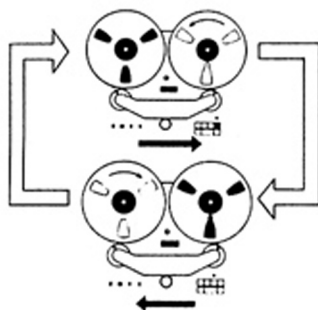
One way reverse playback

CONTINUOUS

One cycle forward recording
 • Automatic stop will be effected at the end of reverse recording.

Continuous playback

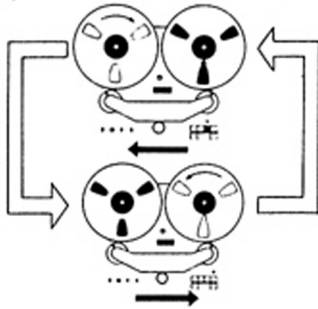
**REV
SELECTOR**

One way reverse recording
 • Automatic stop will be effected at the end of reverse recording.

Continuous playback

HOW TO USE OUTPUT CONTROL DURING RECORDING & PLAYBACK

(Applies only to tapes recorded at or being recorded at optimum recording levels.)

When an external amplifier is employed, it is necessary to match the line output level of the deck with the playback level of the external amplifier.

1. Consider the listening level of FM broadcast through the amplifier as standard.

2. Position the Monitor switch of the amplifier to Tape.
3. Set the deck's MONITOR selector to SOURCE and set the deck's OUTPUT control to the same level as the standard level.
- Adjust the OUTPUT control first before setting the MONITOR selector to TAPE. Since the OUTPUT control is set to the level corresponding to the source level, when the MONITOR selector is set to TAPE the output level may be very loud.

SOUND MIXING

Independent LINE and microphone (MIC) Recording Level controls and input jacks enable signals from microphones and from line sources to be blended and recorded simultaneously on the tape.

Connect a microphone(s) to the MIC jack(s) and connect the

desired source to the LINE IN jacks. Follow the recording procedure and adjust both the LINE and MIC Recording Level controls.

- Line and DIN mixing can also be accomplished if the model is equipped with a DIN jack. In this case, the DIN input level is also adjusted with the MIC Recording Level control.

ABSENTEE RECORDING AND TIMED PLAYBACK

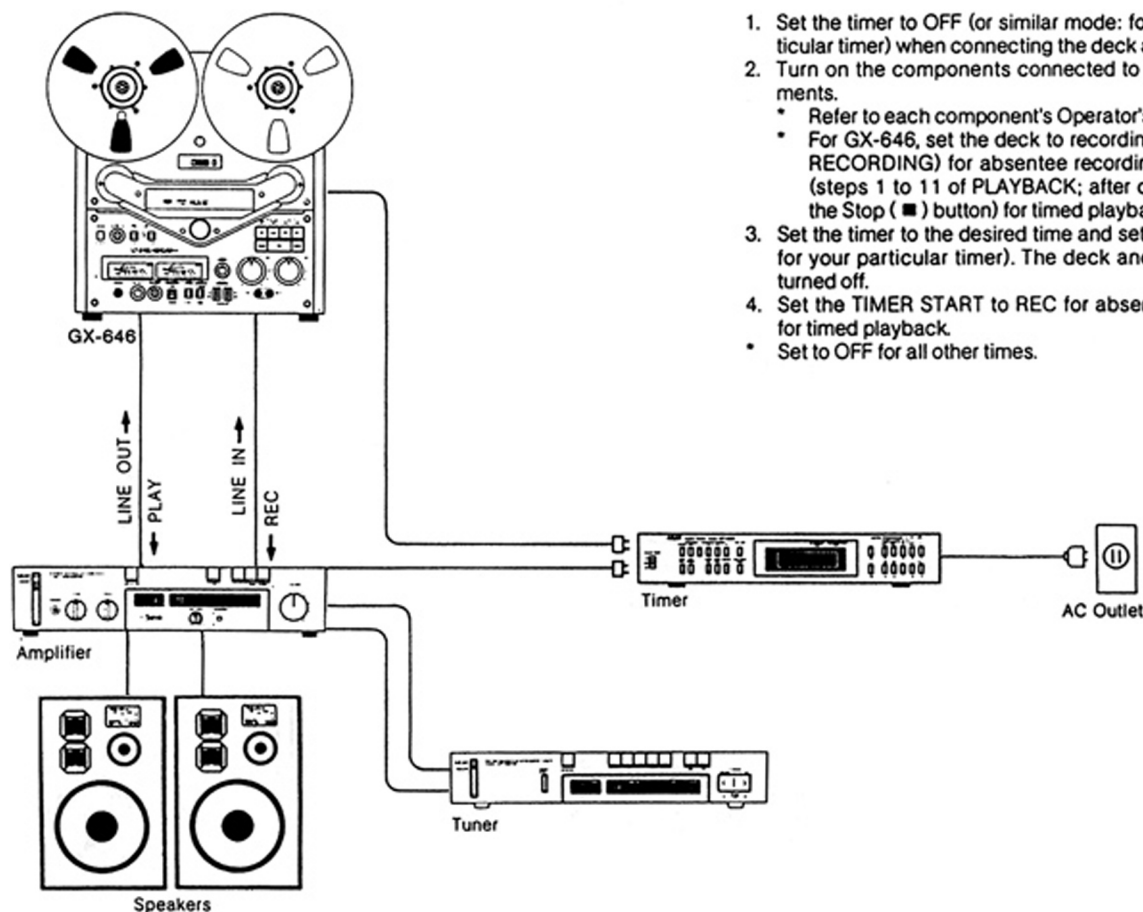

1. Set the timer to OFF (or similar mode: follow directions for your particular timer) when connecting the deck and other components.
2. Turn on the components connected to the timer and make adjustments.
 - Refer to each component's Operator's Manual.
 - For GX-646, set the deck to recording standby (steps 1 to 11 of RECORDING) for absentee recording and to playback standby (steps 1 to 11 of PLAYBACK; after completing step 11 depress the Stop (■) button) for timed playback.
3. Set the timer to the desired time and set to TIMER (follow directions for your particular timer). The deck and other components will be turned off.
4. Set the TIMER START to REC for absentee recording and to PLAY for timed playback.
 - Set to OFF for all other times.

TAPE ERASING

Any signals previously recorded on the tape will be automatically erased as a new recording is made. For erasing only, thread the tape and set the deck to recording mode. No plugs should be connected to the LINE IN jacks and the MIC and LINE Recording Level controls

should be kept at minimum. For quick and complete erasure, a bulk tape eraser is recommended.

- Be sure to set the proper TRACK SELECTOR. If both SELECTORS are set to ON, both the left and right channels will be erased.

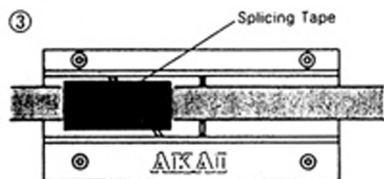
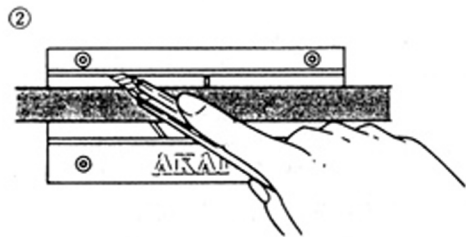
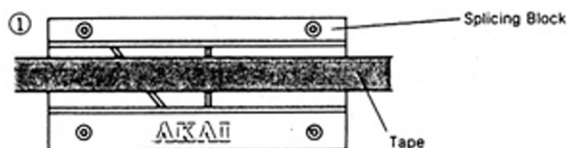

1. After marking the desired connection point, cut the tape at the mark using the standard accessory Tape Splicing Block.
2. Attach the Splicing Tape to the place that has been cut and rub thoroughly with finger to prevent the Splicing Tape from coming off.

3. Tape connection is completed by cutting the excessive portion of splicing tape with a cutter.
 - When a recorded tape has torn apart due to wear, etc., match the ends and connect them using the Splicing Tape.
 - The tape may be cut with scissors, but it will adversely affect recording when magnetized scissors are used.

MAINTENANCE

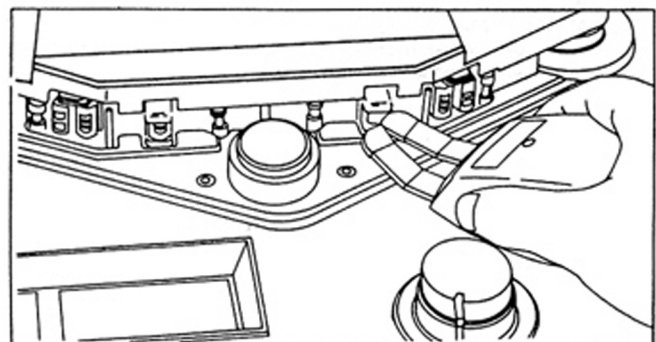
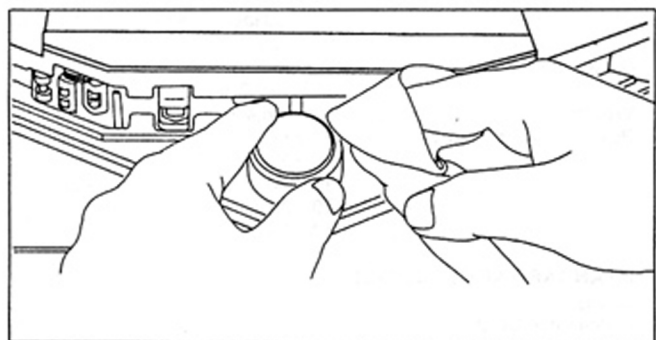
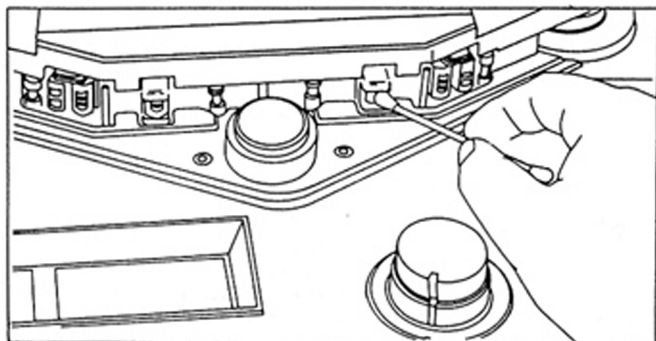

Turn off the POWER switch.

HEAD BLOCK CLEANING

HEADS

The GX heads do not require a great deal of cleaning. However, if old tapes or tapes which have been spliced are used, GX head cleaning is recommended.

Clean recording, playback, and erase heads with a cotton swab stick which has been dipped in AKAI cleaning fluid from the Head Cleaning Kit HC-550P.

PINCH WHEEL AND CAPSTAN

If foreign matter is allowed to accumulate on the pinch wheel and capstan, these particles will come off on the tape causing deterioration of sound quality. Oil adhering to the capstan also causes irregularity in tape transport. Therefore, it is also recommended that these parts be wiped clean periodically. Use AKAI cleaning fluid or alcohol.

- Do not use chemicals such as chloroethane, etc. for head block cleaning as the rubber parts will deteriorate.

HEAD DEMAGNETIZING

Prolonged use of the deck will gradually build up residual magnetism on the heads. The effect of magnetization is that it causes a considerable drop in high frequency response and introduces noise into your recordings. It is therefore, recommended that head demagnetizing be performed periodically. This can be accomplished with a head demagnetizer by bringing the prongs of the demagnetizer close to the heads and making several small circular motions over all head surface areas as well as the head housing.

- Do not use magnetized tools in the vicinity of the heads and VU Meters.
- Do not bring the demagnetizer close to the VU Meters.

TROUBLESHOOTING

The conditions listed below do not indicate mechanical failure of the deck. If your deck exhibits any of these conditions, check for trouble as indicated below.

SYMPTOM	CAUSE	REMEDY
Loss of sensitivity and tone quality.	<ul style="list-style-type: none"> • Dirty Erase head. • Wrong side of tape facing the heads. • TAPE SELECTOR is set incorrectly. • Magnetized head. 	<ul style="list-style-type: none"> • Refer to HEAD BLOCK CLEANING. • Reload. • Set correctly. • Refer to HEAD DEMAGNETISING.
No recording or playback.	<ul style="list-style-type: none"> • Incorrect setting of controls and/or connections wrong. • "L" and "R" TRACK SELECTORS set incorrectly. • OUTPUT control at minimum. 	<ul style="list-style-type: none"> • Refer to CONTROLS and CONNECTIONS FOR RECORDING AND PLAYBACK. • Reset. • Adjust.
Irregularity in tape transport.	<ul style="list-style-type: none"> • Oil or magnetic particles adhering to the Capstan or Pinch Wheel. • Sticky or dirty tape surface. • Improperly loaded tape. 	<ul style="list-style-type: none"> • Refer to HEAD BLOCK CLEANING. • Change tape. • Refer to TAPE LOADING.
Tape will not run.	<ul style="list-style-type: none"> • Power is not being supplied. • Not enough tension. • Twisted or sticky tape. 	<ul style="list-style-type: none"> • Connect. • Take up slack. • Change tape.
Previously recorded program will not erase.	<ul style="list-style-type: none"> • Erase head is dirty. 	<ul style="list-style-type: none"> • Refer to HEAD BLOCK CLEANING.
Distorted or noisy sound.	<ul style="list-style-type: none"> • Recording level is too high. • Incorrect setting of external controls and/or connections wrong. 	<ul style="list-style-type: none"> • Refer to RECORDING. • Set and/or connect correctly.

Should there be a problem, write down the model name, serial numbers and all pertinent data regarding warranty coverage as well as a clear description of the existing trouble, and contact your nearest authorized Akai Service Station or the Service Department of Akai Company, Tokyo, Japan.

SPECIFICATION

Track System	4 Track 2 Channel Stereo System
Reel Capacity	Up to 10" reel
Heads	GX head for recording x 2 GX head for playback x 2 Erase head x 2
Motors	AC Servo motor for capstan drive x 1 AC Eddy current motor for reel drive x 2
Tape Speed	19 cm/s $\pm 0.8\%$ (7-1/2 ips.) 9.5 cm/s $\pm 1.0\%$ (3-3/4 ips.) (Pitch control: more than $\pm 6\%$)
Wow & Flutter	Less than 0.03% WRMS, 0.07% DIN 45 500 at 19 cm/s Less than 0.04% WRMS, 0.09% DIN 45 500 at 9.5 cm/s
Tape Winding Time	75 sec. using a 360 m (1200 ft.) Tape
Frequency Response (EE Tape)	25 to 33,000 Hz ± 3 dB (-20 VU) at 19 cm/s 25 to 26,000 Hz ± 3 dB (0 VU) 25 to 25,000 Hz ± 3 dB (-20 VU) at 9.5 cm/s 25 to 15,000 Hz ± 3 dB (0 VU)
Signal to Noise Ratio	Better than 65 dB at 19 cm/s (DIN 45 500)
Harmonic Distortion	Less than 0.4% at 19 cm/s
Input	MIC: 0.25 mV (input impedance 5.0 kohms) Required microphone impedance: 600 ohms Line: 70 mV (input impedance 100 kohms)

Output	Line: 0.775 V at 0 VU Required load impedance: more than 20 kohms Phone: 1.3 mW/8 ohms at 0 VU
DIN	Input: 2 mV (input impedance 10 kohms) Output: 0.3 V Required load impedance: more than 20 kohms
Dimensions	440 (W) x 483 (H) x 256 (D) mm (17.3 x 19.0 x 10.1")
Weight	21 kg (46.4 lbs)
Power Requirements	120 V 60 Hz for U.S.A & Canada 220 V 50 Hz for Europe except U.K. 240 V 50 Hz for U.K. & Australia 110/120/220/240V switchable 50/60 Hz for the other countries

STANDARD ACCESSORIES

Empty Reel	1
Connection Cords	1 set
Sensing Tape Kit	1
Reel Adaptor	2
Operator's Manual	1

* For improvement purposes, specifications and design are subject to change without notice.