

SERVICE MANUAL

PARTS LIST

AKAI STEREO TAPE DECK
MODEL 4000B/D

For Service Manuals
MAURITRON SERVICES
8 Cherry Tree Road, Chinnor
Oxfordshire, OX9 4QY.
Tel (01844) 351694
Fax (01844) 352554
email: - mauritron@dial.pipex.com

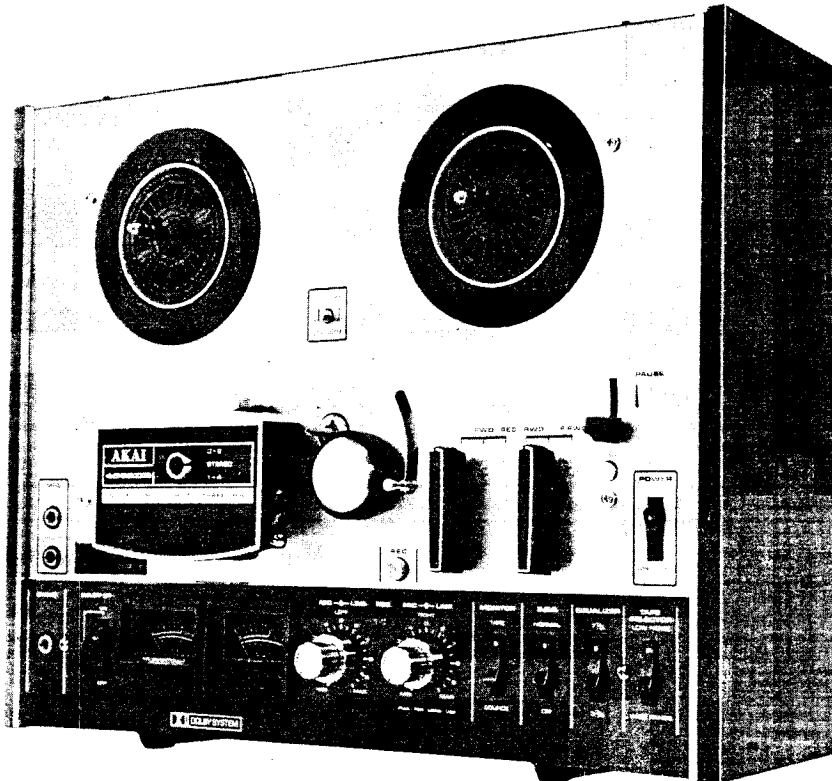

STEREO TAPE DECK

MODEL 4000DB

For Service Manuals Contact
MAURITRON TECHNICAL SERVICES
8 Cherry Tree Rd, Chinnor
Oxon OX9 4QY
Tel:- 01844-351694 Fax:- 01844-352554
Email:- enquiries@mauritron.co.uk

SECTION 1	SERVICE MANUAL	3
SECTION 2	PARTS LIST	27
SECTION 3	SCHEMATIC DIAGRAM	48

For Service Manuals Contact
MAURITRON TECHNICAL SERVICES
8 Cherry Tree Rd, Chinnor
Oxon OX9 4QY
Tel:- 01844-351694 Fax:- 01844-352554
Email:- enquiries@mauritron.co.uk

SECTION 1

SERVICE MANUAL

TABLE OF CONTENTS

I.	SPECIFICATIONS	4
II.	D.C. RESISTANCE OF VARIOUS COILS	6
III.	MEASURING METHOD	7
	1. TAPE SPEED DEVIATION	7
	2. WOW AND FLUTTER	7
	3. FREQUENCY RESPONSE	7
	4. SIGNAL TO NOISE RATIO	7
	5. TOTAL HARMONIC DISTORTION FACTOR	8
	6. CROSS TALK (Cross talk between the tracks)	8
	7. ERASE RATIO	8
IV.	DISMANTLING OF UNIT	9
V.	MECHANISM ADJUSTMENT	10
	1. PINCH WHEEL PRESSURE MEASUREMENT	10
	2. SUPPLY REEL SHAFT ASSEMBLY ADJUSTMENT	10
	3. TAKE-UP REEL SHAFT ASSEMBLY ADJUSTMENT	10
	4. DRIVE BELT POSITION ADJUSTMENT	12
	5. FLYWHEEL LOOSE PLAY ADJUSTMENT	12
	6. ADJUSTMENT OF IDLER #2 POSITION AT FAST FORWARD MODE	12
	7. AUTOMATIC SHUT-OFF OPERATING POINT ADJUSTMENT	14
	8. SHIFTER LEVER POSITION ADJUSTMENT	14
VI.	HEAD ADJUSTMENT	15
	1. HEAD HEIGHT ADJUSTMENT	15
	2. HEAD AZIMUTH ALIGNMENT ADJUSTMENT	15
VII.	AMPLIFIER SYSTEM ADJUSTMENT	16
	1. CONNECTION OF VARIOUS INSTRUMENTS	16
	2. ADJUSTMENT SEMI-FIXED RESISTOR AND TRIMMER CONDENSER POSITION	16
	3. PRIOR TO ADJUSTMENT	17
	4. PLAYBACK LEVEL ADJUSTMENT	17
	5. MONITOR LEVEL ADJUSTMENT	18
	6. RECORDING LEVEL ADJUSTMENT USING LOW NOISE TAPE	18
	7. RECORDING LEVEL ADJUSTMENT USING WIDE RANGE TAPE	18
	8. FREQUENCY RESPONSE ADJUSTMENT (Recording Bias Adjustment)	18
	9. RECORDING BIAS FREQUENCY CHECK	18
	10. RECORDING BIAS VOLTAGE AND ERASE VOLTAGE	18
VIII.	DOLBY NR AMP. ADJUSTMENT	19
	1. RECORDING DOLBY NR CIRCUIT ADJUSTMENT	20
	2. PLAYBACK DOLBY NR CIRCUIT CONFIRMATION	20
IX.	DOLBY NOISE REDUCTION CIRCUIT OPERATION	21
	1. RECORDING DOLBY NR CIRCUIT OPERATION	21
	2. PLAYBACK DOLBY NR CIRCUIT OPERATION	23
X.	COMPOSITE VIEWS OF COMPONENTS	24

I. SPECIFICATIONS

An asterisk next to a figure indicates the minimum guaranteed performance.

TRACK SYSTEM	4-track 2-channel stereo monaural system
REEL CAPACITY	Up to 7" reel
TAPE SPEED	7-1/2 and 3-3/4 ips. $\pm 2\%$ (* $\pm 3\%$) Playback a 1,000 Hz 7-1/2 ips. pre-recorded test tape
WOW AND FLUTTER	Less than 0.15% (*0.22%) at 7-1/2 ips. Less than 0.2% (*0.3%) at 3-3/4 ips. Playback a 3,000 Hz pre-recorded test tape
TOTAL WOW AND FLUTTER	*Less than 0.28% at 7-1/2 ips. 3,000 Hz recording and playback
FREQUENCY RESPONSE	30 to 23,000 Hz ± 3 dB at 7-1/2 ips. 30 to 16,000 Hz ± 3 dB at 3-3/4 ips.
WIDE RANGE (AKAI SRT TAPE)	*40 to 22,000 Hz ± 3 dB at 7-1/2 ips. *40 to 14,000 Hz ± 3 dB at 3-3/4 ips.
LOW NOISE (SCOTCH #211 TAPE)	*40 to 20,000 Hz ± 3 dB at 7-1/2 ips. *40 to 14,000 Hz ± 3 dB at 3-3/4 ips.
DISTORTION FACTOR	Less than 1.0% (1,000 Hz 0VU recording)
TOTAL DISTORTION FACTOR	*Less than 1.5% at 7-1/2 and 3-3/4 ips. 1,000 Hz 0VU recording SCOTCH #211 tape
PLAYBACK OUTPUT LEVEL	0.775V (0 dBm ± 1.0 dB) using a 250 Hz 7-1/2 ips. pre-recorded test tape
LINE OUTPUT	0.5V
DIN OUTPUT	0.5V
HEADPHONE OUTPUT	30 mV at 8 Ω
INPUTS	MIC INPUT More than 0.4 mV
	LINE INPUT More than 70 mV
	DIN INPUT More than 2.5 mV/low and 75 mV/high
RECORDING/PLAYBACK LEVEL	WIDE RANGE 0 ± 0.5 dB 1,000 Hz 0VU recording
	LOW NOISE 0 ± 1.0 dB 1,000 Hz 0VU recording
SIGNAL TO NOISE RATIO	Better than 55 dB (*50 dB)
TOTAL SIGNAL TO NOISE RATIO	*Better than 45 dB Recording volume at 180 degree position from MIN.
CROSS TALK	Better than 65 dB (*60 dB) (monaural) Better than 40 dB (stereo) 1,000 Hz +3 VU recording
ERASE RATIO	Better than 70 dB 1,000 Hz +3 VU recording
RECORDING BIAS FREQUENCY	105 kHz $\pm 5\%$
BIAS LEAK	Less than -25 VU Dolby SW OFF, Monitor SW TAPE
HIGH FREQUENCY DEVIATION	Within 2 dB Playback a 8,000 Hz 3-3/4 ips. pre-recorded test tape at 7-1/2 ips.
RECORDING CAPACITY	90 min. stereo recording using a 1,800 ft. tape at 7-1/2 ips.
FAST FORWARD AND REWIND TIME	Within 4 min. and 40 sec./3 min. 40 sec. using a 1,800 ft. tape at 50/60 Hz
MOTOR	4-Pole Induction 1-speed motor Type: SSM-1 Revolutions: 1,500/1,800 r.p.m. at 50/60 Hz
HEADS	ERASE HEAD Type: E4-200 Gap: 0.6 mm Impedance: 200 Ω $\pm 5\%$ at 100 kHz D.C. Resistance: 2 Ω
	RECORDING HEAD Type: P4-154 Gap: 1 micron Impedance: 95 Ω $\pm 15\%$ at 1 kHz D.C. Resistance: 14.2 Ω
	PLAYBACK HEAD Type: P4-150 Gap: 1 micron Impedance: 1,250 Ω $\pm 15\%$ at 1 kHz D.C. Resistance: 90 Ω

For Service Manuals Contact
MAURITRON TECHNICAL SERVICES
8 Cherry Tree Rd, Chinnor
Oxon OX9 4QY
Tel: 01844-351694 Fax: 01844-352554
Email: enquiries@mauritron.co.uk

TRANSISTORS	2SA628(D) (E) ... 2 2SC458(C) (D) ... 6 2SC458LG(C) ... 4 2SC458LG(C) (D) ... 6	2SC711(E) (F) ... 4 2SC1098 ... 1 2SC1247A(B) (V) ... 2 2SC1312(G) ... 2
I.C.	LD3141 ... 4	
DIODES	1N34A ... 6 10DC1 (Blk) ... 1 WG599 ... 6	WZ085 ... 2 WZ240 ... 1
FET	2SK30A (GR) ... 2	
POWER SUPPLY	100 to 240V A.C. 50/60 Hz for Universal models 120V A.C. 60 Hz for CSA/UL models 220V A.C. 50 Hz for CEE models	
POWER CONSUMPTION	40W	
DIMENSIONS	406(W) x 325(H) x 196(D) mm (16.0" x 12.8" x 7.7")	
WEIGHT	12 kg. (26.4 lbs.)	

NOTE: Specifications subject to change without notice.

II. D.C. RESISTANCE OF VARIOUS COILS

The D.C. Resistance values shown in this chart are average values.

PART	DESIGNATION	D.C. RESISTANCE
MOTOR	SSM-1	Between BLU-RED 120Ω Between BLU-YLW 190Ω
ERASE HEAD	EH-200	2Ω
RECORDING HEAD	P4-154	14.2Ω
PLAYBACK HEAD	P4-150	90Ω
HEADPHONE TRANSFORMER	N16-535S	Primary 565Ω ±15% Secondary 0.95Ω ±15%
OSCILLATOR COIL	OT-204	Between 1-3 0.3Ω Between 4-6 0.7Ω Between 7-9 8.4Ω
POWER TRANSFORMER	LET-16	Refer to Fig. 1

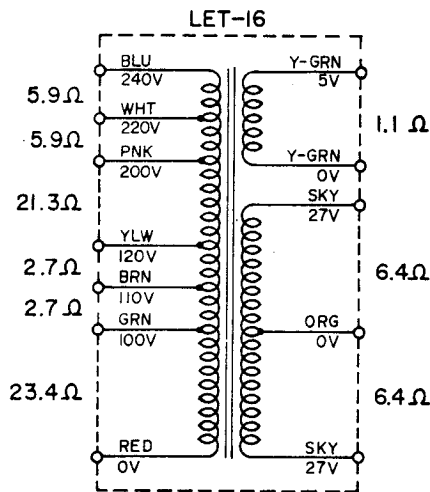

Fig. 1

For Service Manuals Contact
MAURITRON TECHNICAL SERVICES
 8 Cherry Tree Rd, Chinnor
 Oxon OX9 4QY
 Tel: 01844-351694 Fax: 01844-352554
 Email: enquiries@mauritron.co.uk

III. MEASURING METHOD

1. TAPE SPEED DEVIATION

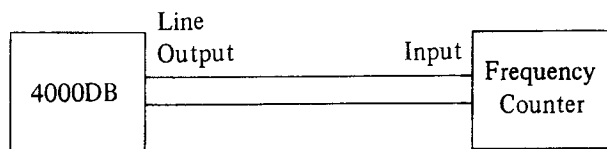

Fig. 2

As shown in Fig. 2, connect a Frequency Counter to the Line Output of Model 4000DB. Playback a 1,000 Hz pre-recorded test tape. Take a Frequency Counter reading at the beginning, middle, and end of tape winding during playback and obtain the tape speed deviation from the following formula.

$$\text{TAPE SPEED DEVIATION (\%)} = \frac{\text{Frequency Counter reading (Hz)} - 1,000 \text{ Hz}}{1,000 \text{ Hz}} \times 100$$

2. WOW AND FLUTTER

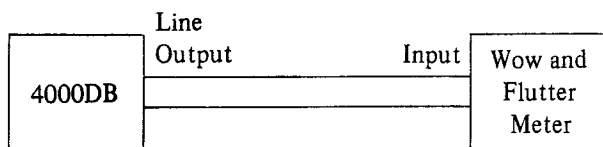

Fig. 3

Method A

As shown in Fig. 3, connect a Wow and Flutter Meter to the Line Output of Model 4000DB. Playback a 3,000 Hz pre-recorded test tape and take a Wow and Flutter reading at the beginning, middle, and end of tape winding during playback.

The maximum value on these respective readings will represent the Wow and Flutter.

Method B

Supply a 3,000 Hz sine wave signal from an Audio Frequency Oscillator and make a recording on a blank tape at the beginning, middle, and end of tape winding. Rewind and playback the resultant signal. Measure Wow and Flutter with a Wow and Flutter Meter. (The Wow and Flutter value of method B will be close to 2 times of method A.)

3. FREQUENCY RESPONSE

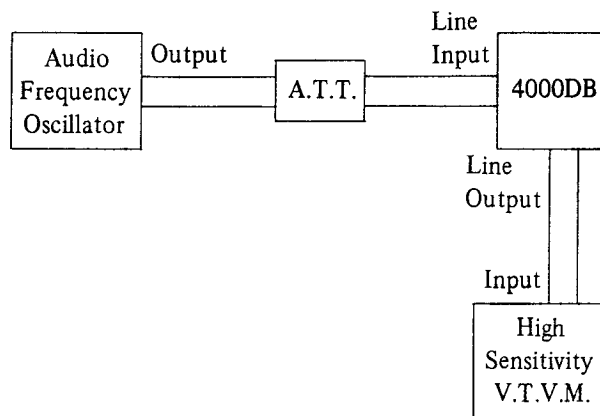

Fig. 4

For measuring Frequency Response, connect instruments as shown in Fig. 4 and proceed as follows.

- 1) Supply a 1,000 Hz sine wave signal to the Line Input of Model 4000DB from an Audio Frequency Oscillator through an Attenuator.
- 2) Set Deck to recording mode and turn recording level control to maximum. Adjust Attenuator to obtain a 0 dBm High Sensitivity V.T.V.M. reading.
- 3) Under conditions described in 2) above, readjust Attenuator so that the Line output is -20 dBm, and record 40 to 20,000 Hz spot frequencies.
- 4) Take High Sensitivity V.T.V.M. spot frequency readings and plot the values on a graph.

NOTE: When measuring Frequency Response, new tape should be used.

4. SIGNAL TO NOISE RATIO

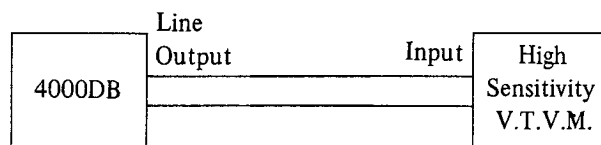

Fig. 5

As shown in Fig. 5, connect a High Sensitivity V.T.V.M. to the Line Output of Model 4000DB. Playback a 250 Hz 0VU pre-recorded test tape and measure the Output level. Then remove the tape and measure the noise level under the same condition. Convert each of the measured values into decibels.

5. TOTAL HARMONIC DISTORTION FACTOR

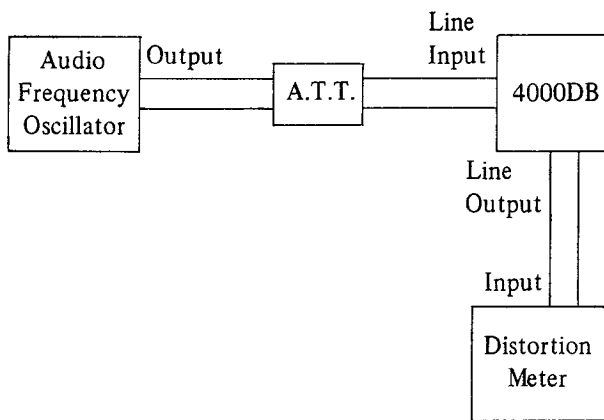

Fig. 6

Connect the measuring instruments as shown in Fig. 6 and record a 1,000 Hz sine wave signal at 0 VU. Playback the resultant signal and measure the overall distortion factor.

- NOTE: 1. At this time, distortion of the Audio Frequency Oscillator must be sufficiently small.
2. When measuring the distortion factor, new tape should be used.

6. CROSS TALK (Cross talk between the tracks)

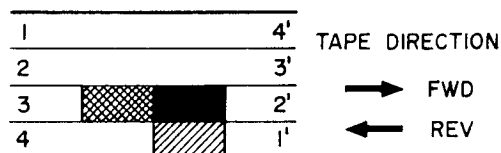

Fig. 7

As shown in Fig. 7 first record a 1,000 Hz sine wave signal on track No. 3 at +3VU level. Next, record under a non-input condition. Then playback the tape on track No. 3 and 1' (reversed condition of tape) through the B.P.F. (1,000 Hz Band Pass Filter, sensitivity 1,000 Hz, ratio 1:1) and obtain the ratio from the following formula.

$$C = 20 \log \frac{E_0}{E_2 - E_1} \text{ (dB)}$$

- Where, C = Desired cross talk ratio (dB)
 E_0 = 1,000 Hz signal output level (V)
 E_2 = 1,000 Hz cross talk level (V)
 E_1 = Non-input cross talk level (V)

7. ERASE RATIO

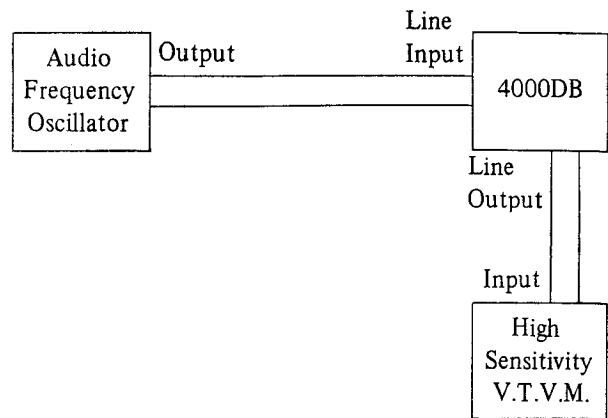

Fig. 8

As shown in Fig. 8, connect a High Sensitivity V.T.V.M. to the Line Output. Playback a virgin tape and take a V.T.V.M. reading of the output level. Next record a 1,000 Hz sine wave signal at +3VU, then playback this recorded signal and take a V.T.V.M. reading of the output level. Next, using this pre-recorded tape, record under a non-input condition and take a reading of the noise level output of the erased signal and obtain a ratio between the two from the following formula:

$$E_r = 20 \log \frac{E_0}{E_2 - E_1} \text{ (dB)}$$

- Where, E_r = Desired erase ratio (dB)
 E_0 = 1,000 Hz signal output level (V)
 E_2 = Non-input signal recorded level (V)
 E_1 = Virgin tape noise output level (V)

For Service Manuals Contact
MAURITRON TECHNICAL SERVICES
 8 Cherry Tree Rd, Chinnor
 Oxon OX9 4QY
 Tel:- 01844-351694 Fax:- 01844-352554
 Email:- enquiries@mauritron.co.uk

IV. DISMANTLING OF UNIT

In case of trouble, etc. necessitating disassembly, please disassemble in the order shown in photographs. Reassemble in reverse order.

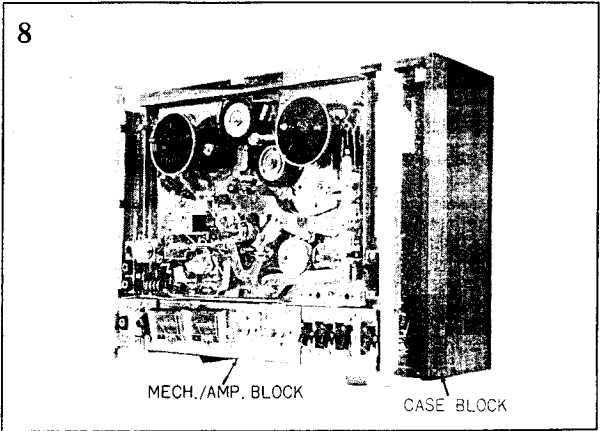
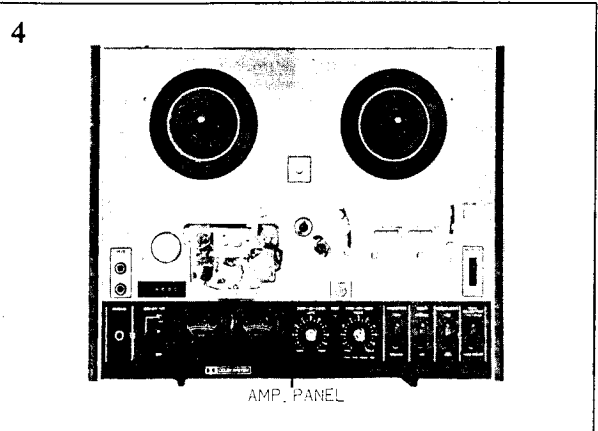
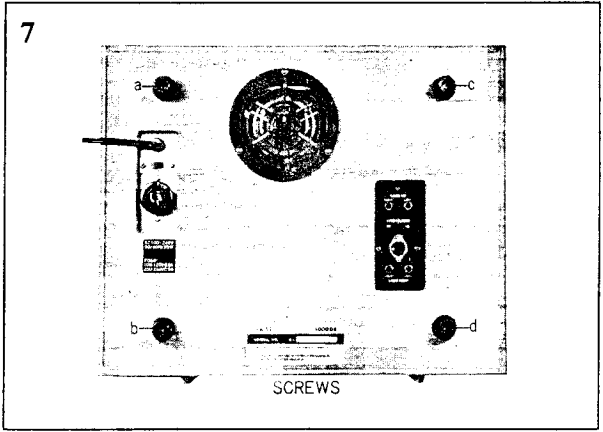
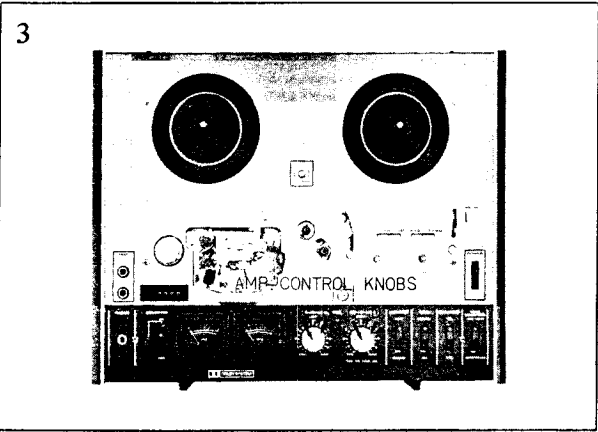
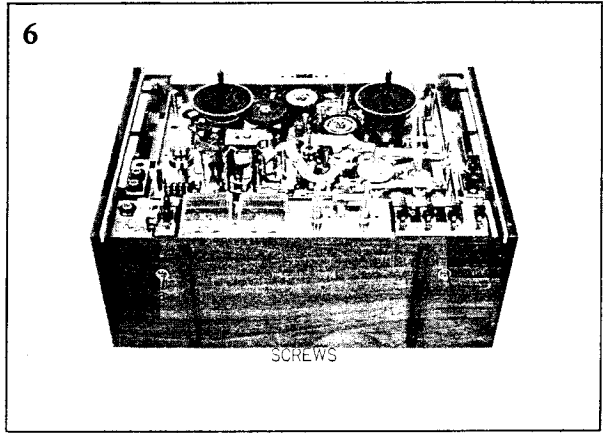
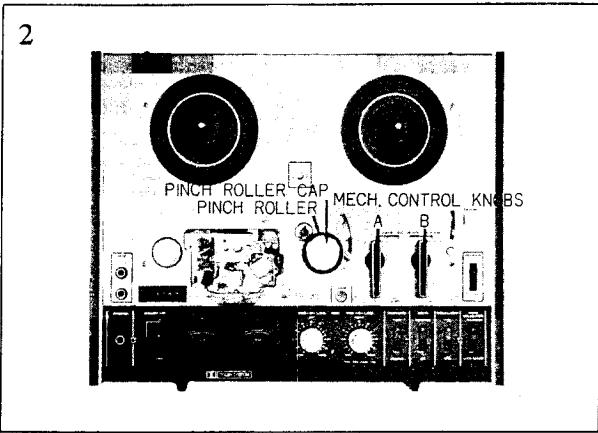
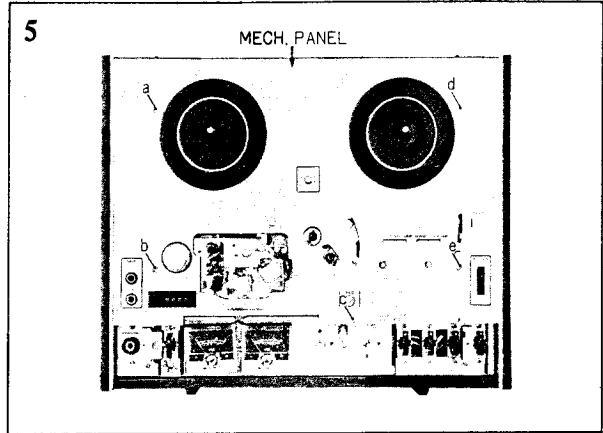
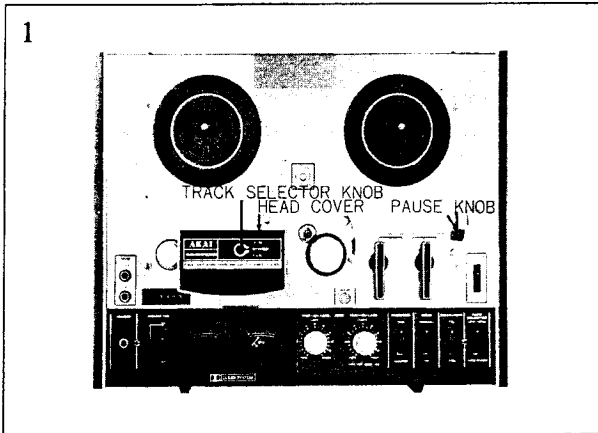

V. MECHANISM ADJUSTMENT

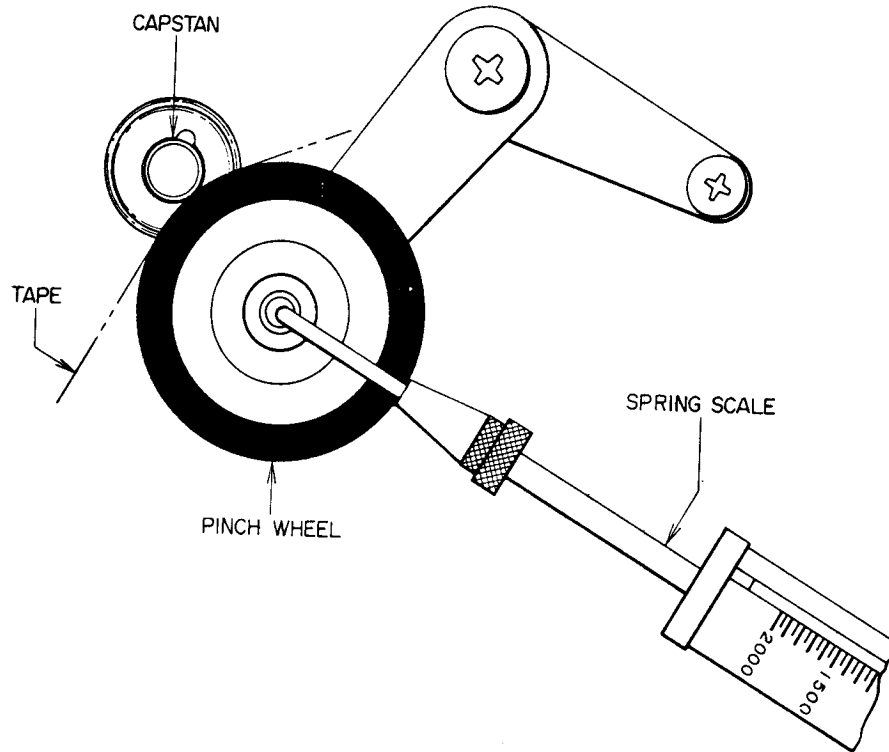

Fig. 9

1. PINCH WHEEL PRESSURE MEASUREMENT (See Fig. 9)

It is important that the pinch wheel shaft be kept in perfect alignment with the capstan shaft. Proper pinch wheel pressure is between 1,150 to 1,200 gr-cm when the unit is operated at the tape speed of 7-1/2 ips. Any deviation from this specification will result in wow and flutter. Check pinch wheel pressure with a spring scale.

For Service Manuals Contact
MAURITRON TECHNICAL SERVICES
8 Cherry Tree Rd, Chinnor
Oxon OX9 4QY
Tel: 01844-351694 Fax: 01844-352554
Email: enquiries@mauritron.co.uk

2. SUPPLY REEL SHAFT ASSEMBLY ADJUSTMENT (See Fig. 10 at left)

Felt clutch material (2) is used between the lower side of the reel table base plate (1) and the rewind pulley (3) to protect recording tape from excessive tension during rewind operation. To check the amount of friction of this part, install a 5" reel on which a 60 mm diameter tape is wound and gently pull the end of tape upward with a spring scale. Adjust the number of washers (4) so that the amount of tension is kept between 400 to 500 gr-cm. Other felt clutch material (5) is attached to the supply roller (6) to provide proper slippage during FWD and REC operation. The procedure for checking friction of this part is the same as the foregoing, and between 80 to 100 gr-cm of tension gives best results.

Adjust the number of washers (7) just under the spring. When the unit is set to fast forward operation, the amount of friction will decrease to from 15 to 20 gr-cm. Check to see whether this is satisfactory. If not, adjust the pressure of the set sleeve (9).

3. TAKE-UP REEL SHAFT ASSEMBLY ADJUSTMENT (See Fig. 10 at right)

Felt clutch material (2) is attached to the bottom side of the reel table base plate (1) so that the recording tape does not stretch during fast forward operation due to excessive tension. To check the amount of friction of this part, install a 5" reel on which a 60 mm diameter tape is wound, and gently pull the end of tape upward with a spring scale. Adjust the number of washers (4) so that the amount of tension at this part is kept between 400 to 500 gr-cm.

Other felt clutch material (10) is attached to the take-up roller (11). This is to provide proper slippage during FWD and REC operation. The procedure for checking friction of this part is the same as the foregoing, and between 150 to 180 gr-cm of friction provides the best results.

Adjust the number of washers (7) just under the spring (11). When the unit is set to rewind operation, the amount of friction of this part will decrease to from 15 to 20 gr-cm. Check to see whether this is satisfactory. If not, adjust the pressure of the pulley (9).

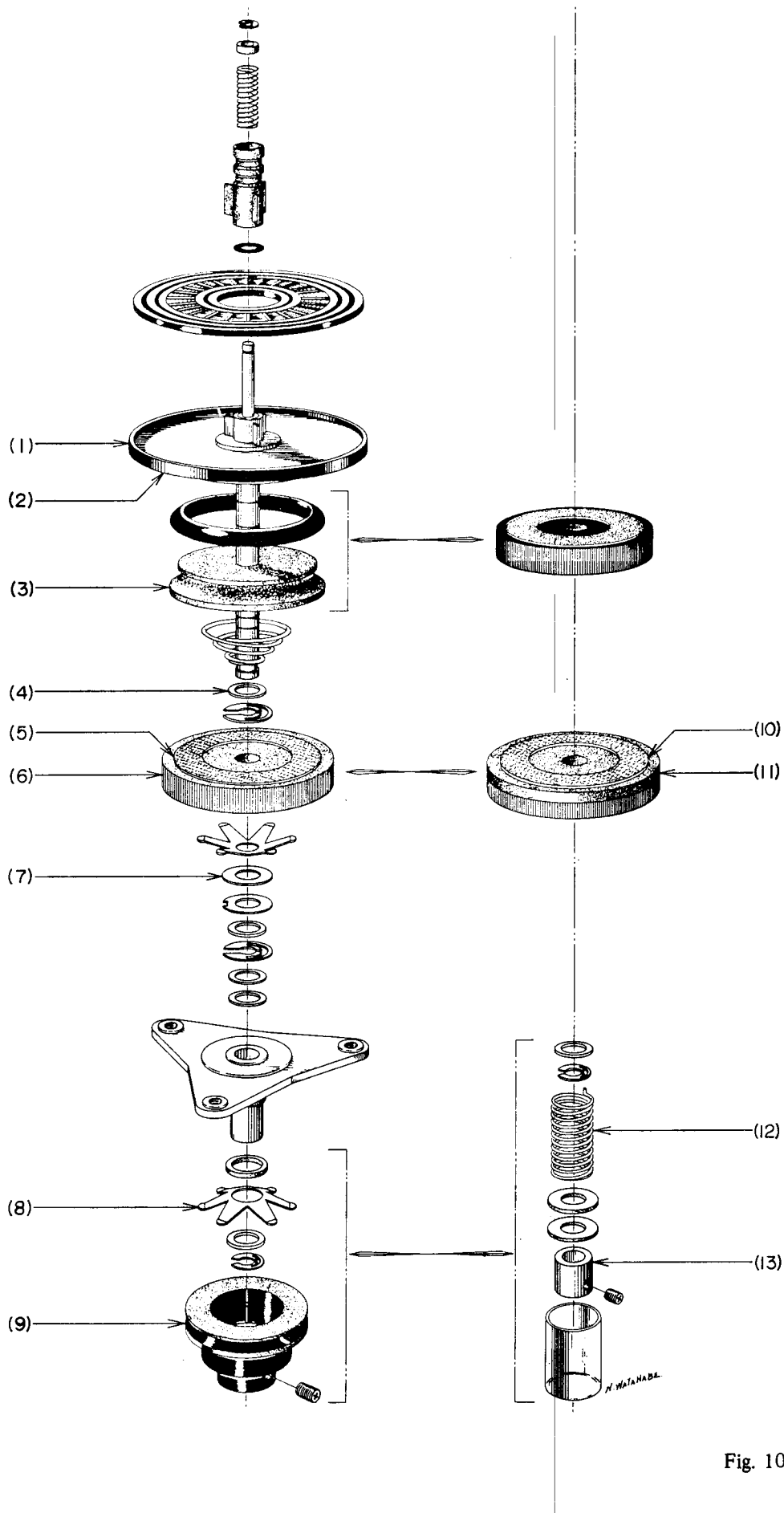

Fig. 10

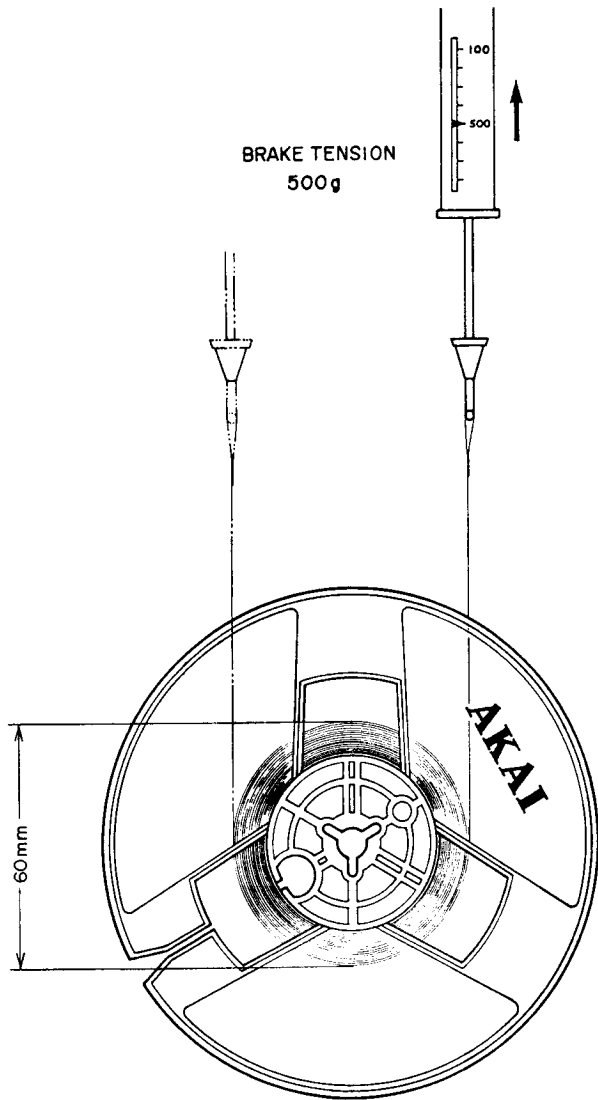

Fig. 11

4. DRIVE BELT POSITION ADJUSTMENT

(See Fig. 12)

Adjust position of drive belt so that it comes to the center of the motor pulley by inserting a washer (or washers) between the motor prop and mechanism chassis as shown in Fig. 12.

5. FLYWHEEL LOOSE PLAY ADJUSTMENT

(See Fig. 13)

With a minus screw driver, turn bearing to left and right and adjust so that when the flywheel is moved as indicated by the arrow mark in the figure, the gap between the steel ball and flywheel supporting plate is 0.3 mm as shown in Fig. 13. Fix at this position with nut.

6. ADJUSTMENT OF IDLER #2 POSITION AT FAST FORWARD MODE

(See Fig. 14)

Move Cam © shown in Fig. 14 up and down as indicated by the arrow mark (↔) in the figure and adjust Lever © height so that Idler #2 contact between Take Up Roller A and the knurling Pulley is uniform when the F.FWD/RWD Lever is set to F.FWD position. Fix at adjusted position with Adjustment Screw ©. During operation, confirm that the rotating position of Idler #2 is ideal.

For Service Manuals Contact
MAURITRON TECHNICAL SERVICES
 8 Cherry Tree Rd, Chinnor
 Oxon OX9 4QY
 Tel:- 01844-351694 Fax:- 01844-352554
 Email:- enquiries@mauritron.co.uk

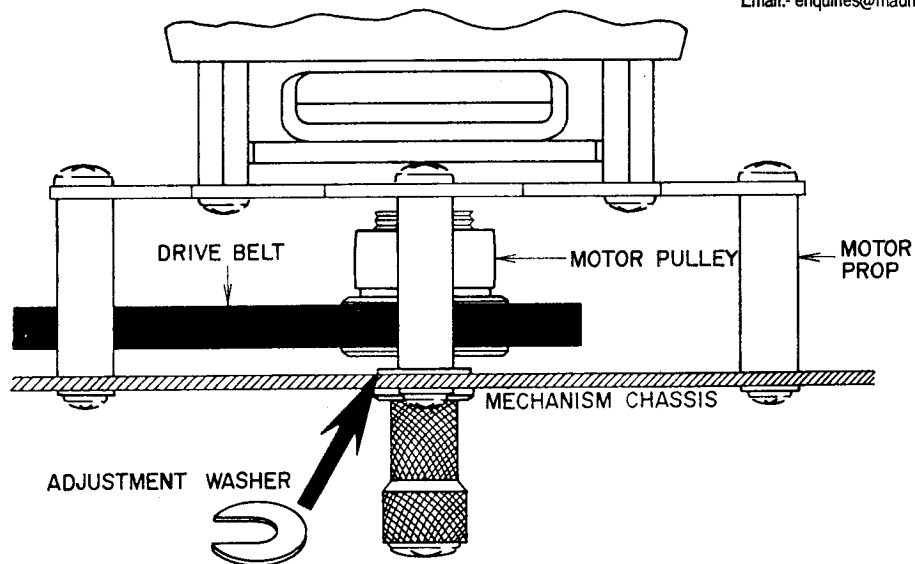

Fig. 12

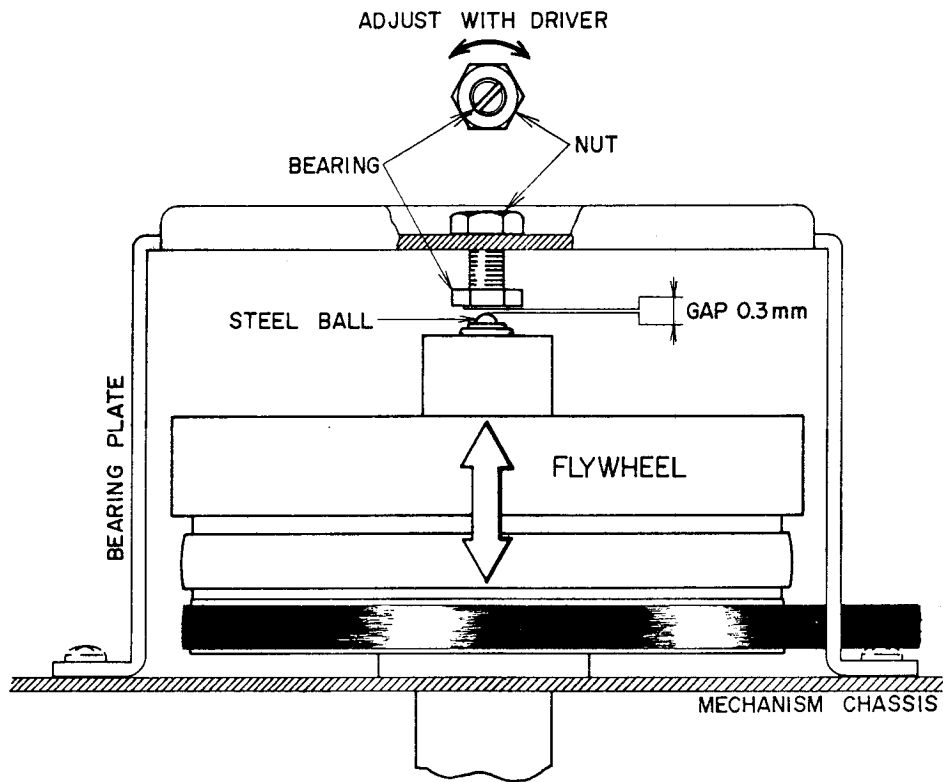

Fig. 13

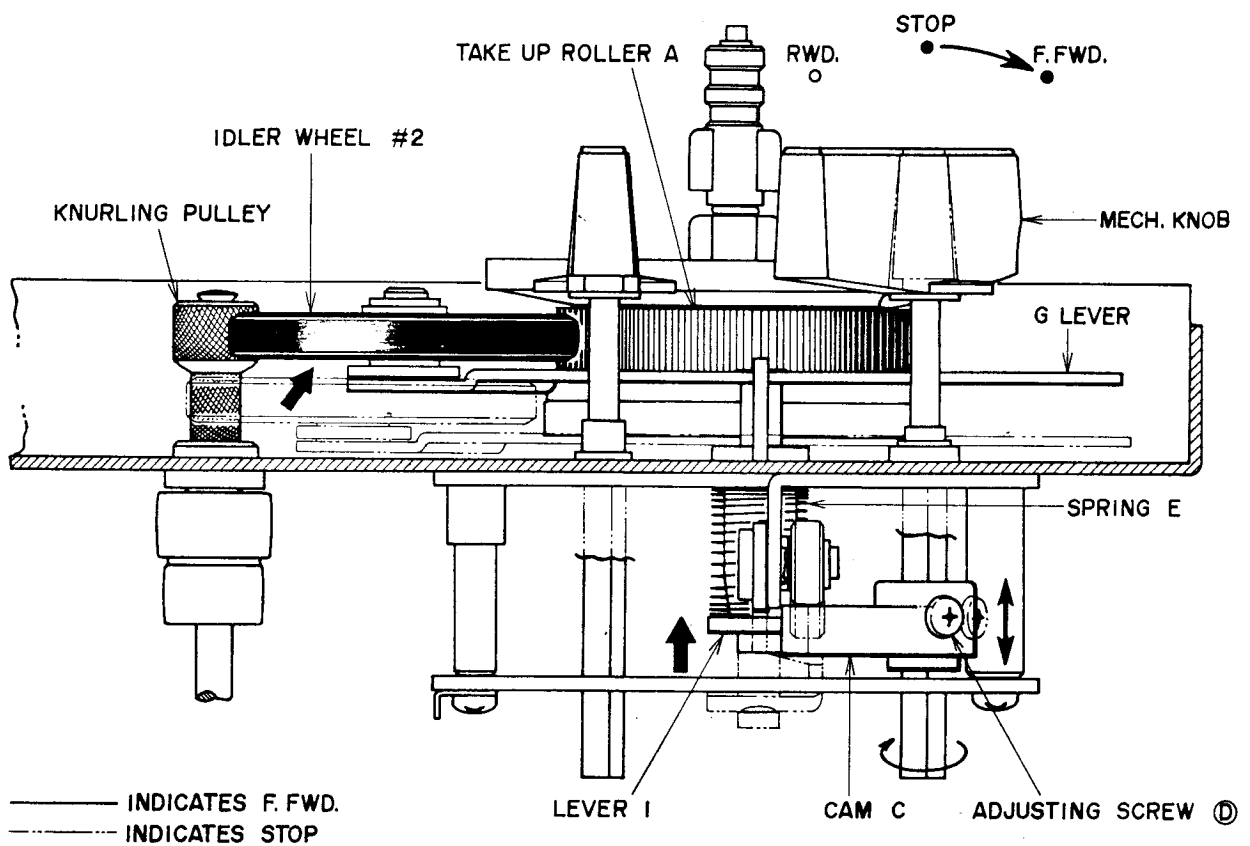
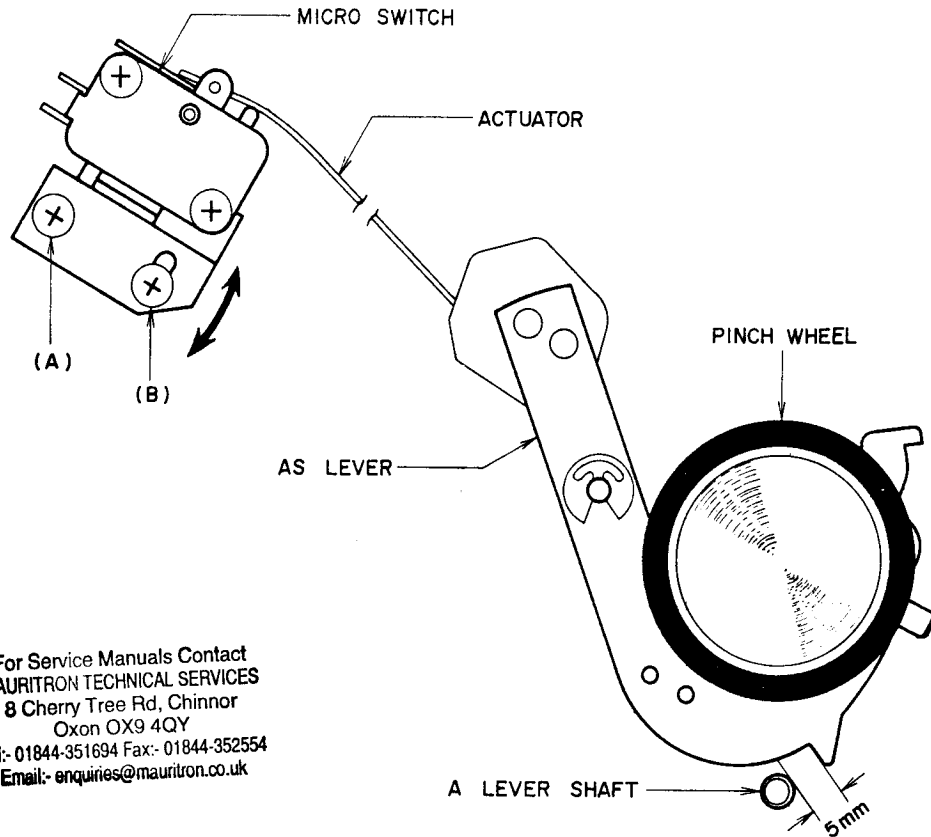

Fig. 14



For Service Manuals Contact
MAURITRON TECHNICAL SERVICES
 8 Cherry Tree Rd, Chinnor
 Oxon OX9 4QY
 Tel:- 01844-351694 Fax:- 01844-352554
 Email:- enquiries@mauritron.co.uk

Fig. 15

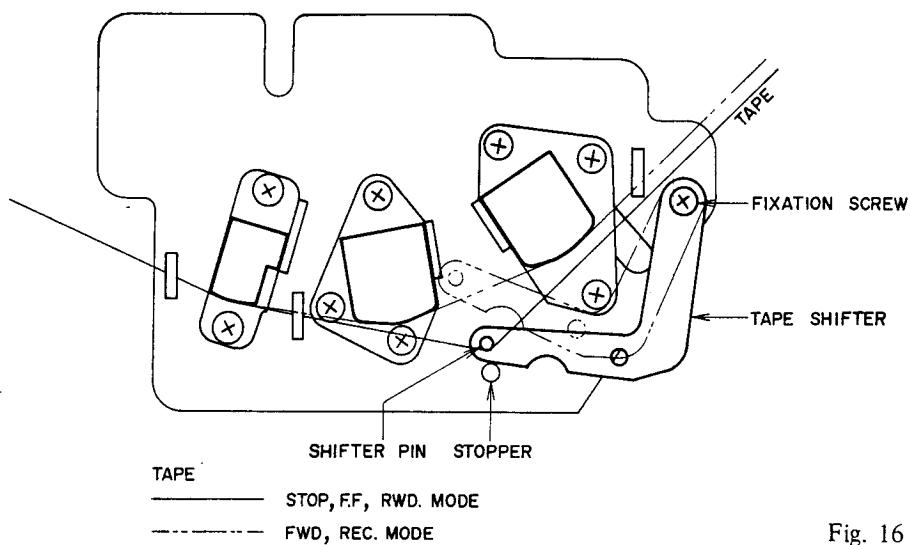

Fig. 16

7. AUTOMATIC SHUT-OFF OPERATING POINT ADJUSTMENT (See Fig. 15)

Loosen screws (A) and (B) and adjust installed position of Micro Switch so that when AS Lever is lowered as a result of the Power Switch being set to SHUT-OFF position, the gap between AS Lever is about 5 mm.

8. SHIFTER LEVER POSITION ADJUSTMENT (See Fig. 16)

- 1) Loosen tape shifter fixation screw and adjust so that at stop mode, the tape shifter contacts the stopper and stops. Tighten fixation screw.
- 2) Confirm that, as shown by - - - line in the figure, the tape does not touch the shifter pin at Fwd and Rec modes.

VI. HEAD ADJUSTMENT

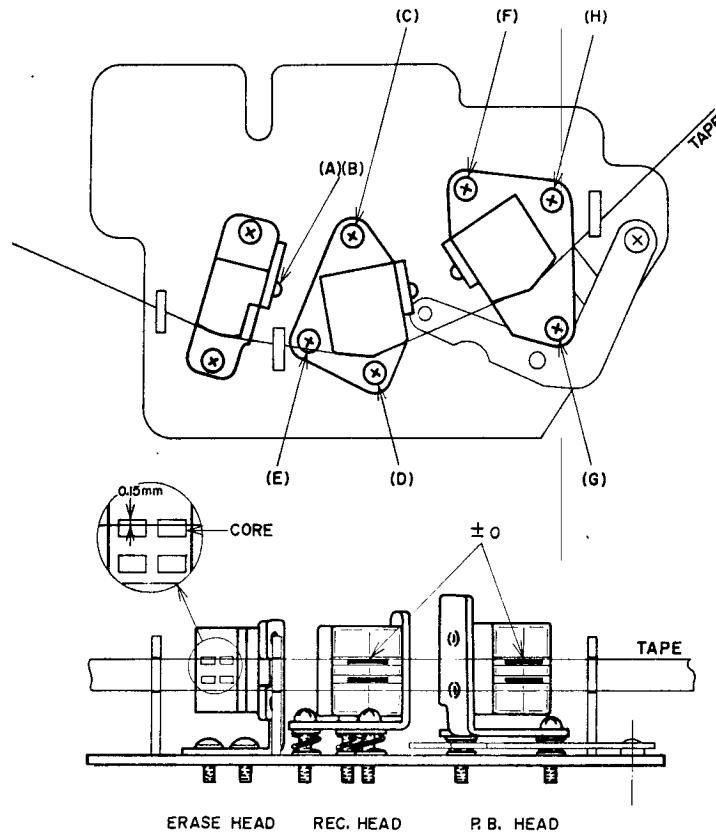

Fig. 17

1. HEAD HEIGHT ADJUSTMENT

(See Fig. 17)

1) Erase Head

Loosen screws (A) and (B) shown in Fig. 17 and adjust erase head height. Tighten screws at position at which the upper edge of the tape is 0.15 mm lower than the upper edge of the left channel head core of the erase head.

2) Recording Head

Adjust head height adjustment screws (C) and (D) shown in Fig. 17 so that the upper edge of the tape and the upper edge of channel 1 head core of the recording head are the same height.

3) Playback Head

Adjust head height adjustment screws (F) and (G) shown in Fig. 17 so that the upper edge of the tape and the upper edge of channel 1 head core of the playback head are the same height.

c. Playback an 8,000 Hz 3-3/4 ips. alignment adjustment test tape.

d. Adjust adjustment screw (H) to obtain maximum High Sensitivity V.T.V.M. indication on both channels.

2) Recording Head

a. Connect an Audio Frequency Oscillator to the line input through an Attenuator, and connect a High Sensitivity V.T.V.M. to the line output. Then load a blank test tape.

b. Set the Monitor Switch to SOURCE and supply a 16,000 Hz sine wave signal. Adjust the Attenuator or the Line Recording Level Controls to obtain a -20 dBm. High Sensitivity V.T.V.M. indication.

c. Reset Monitor Switch to TAPE and set deck to recording mode.

d. Adjust adjustment screw (E) to obtain maximum High Sensitivity V.T.V.M. indication on both channels.

2. HEAD AZIMUTH ALIGNMENT

ADJUSTMENT (See Fig. 17)

1) Playback Head

a. Connect a High Sensitivity V.T.V.M. to the left and right channel Output Terminals of the tape deck.

b. Set the Track Selector to STEREO and set the machine to 7-1/2 ips. tape speed.

NOTES:

1) As head adjustment greatly affects tape deck performance, be sure that these adjustments are carried out properly.

2) Be careful not to use magnetized tools near the heads.

3) As the level of old tape varies greatly, use new tape.

4) Demagnetize heads before and after head adjustment.

VII. AMPLIFIER SYSTEM ADJUSTMENT

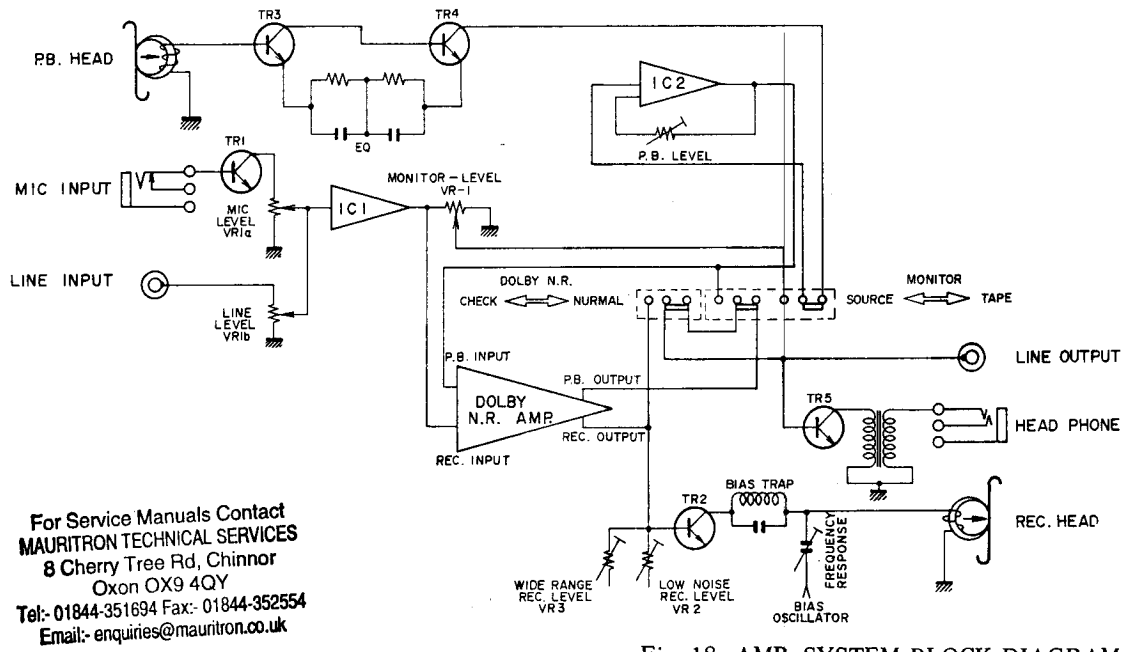

Fig. 18 AMP. SYSTEM BLOCK DIAGRAM

1. CONNECTION OF VARIOUS INSTRUMENTS

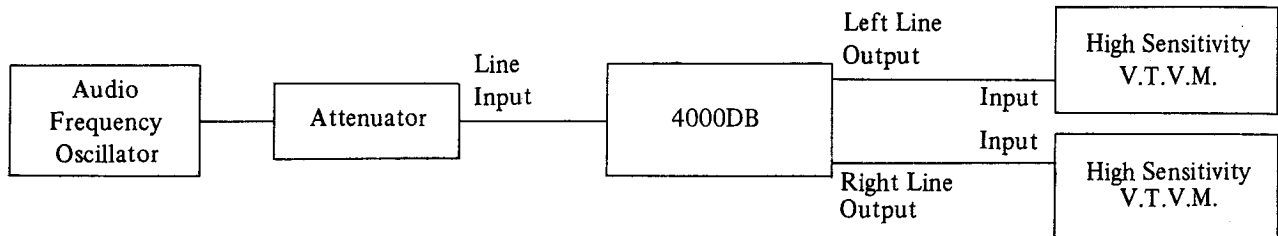

Fig. 19

2. ADJUSTMENT SEMI-FIXED RESISTOR AND TRIMMER CONDENSER POSITION

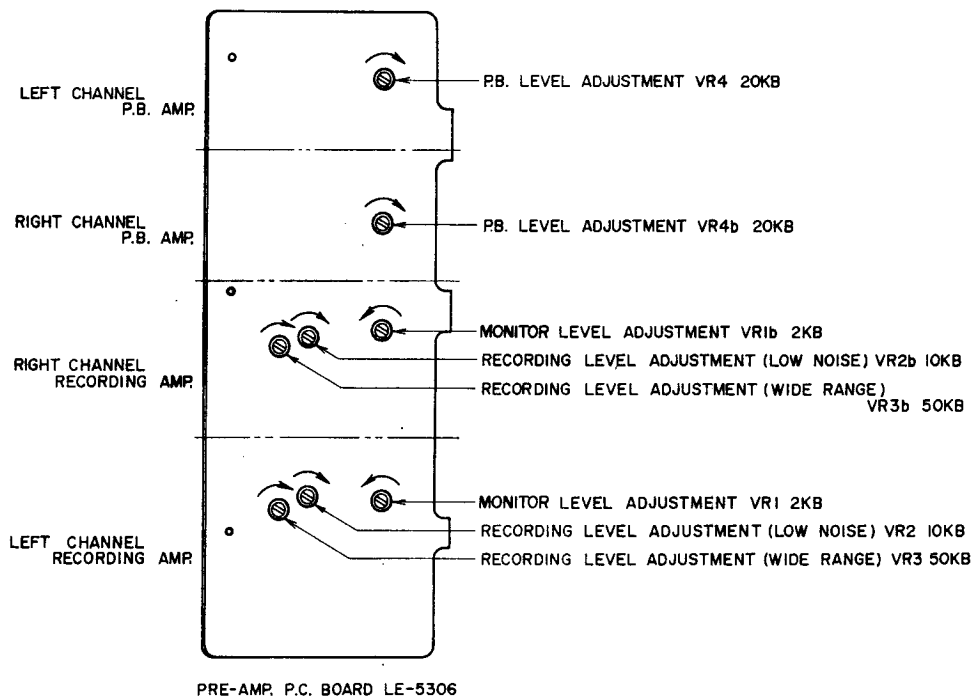

Fig. 20 PRE AMP. P.C. BOARD LE-5306

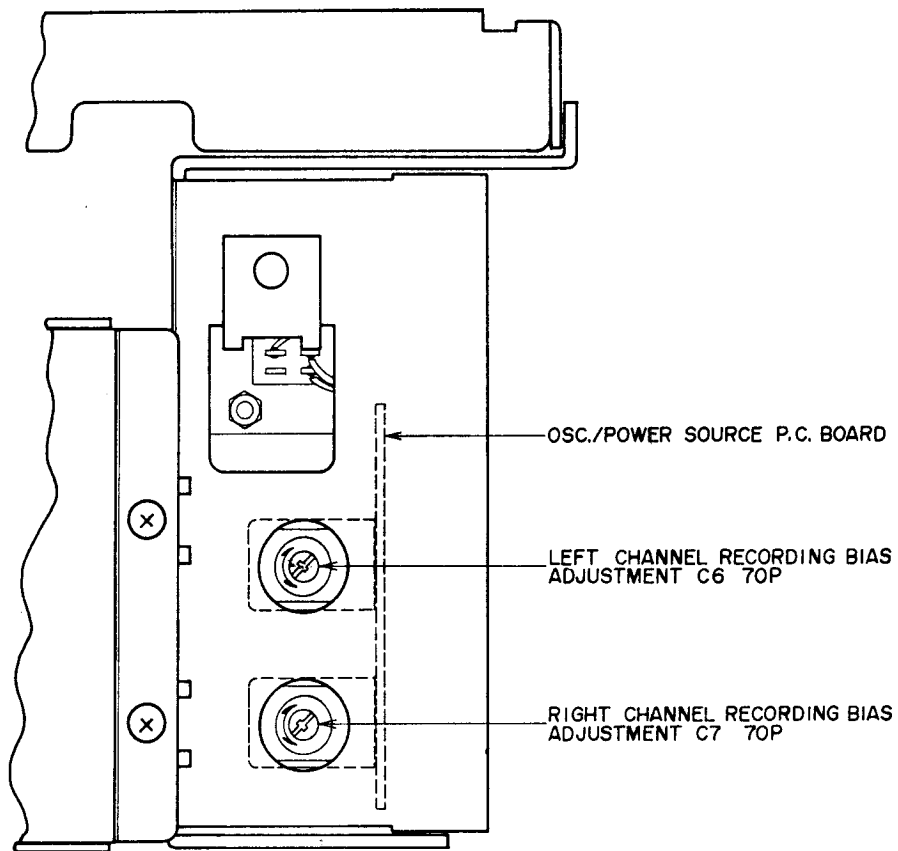

Fig. 21

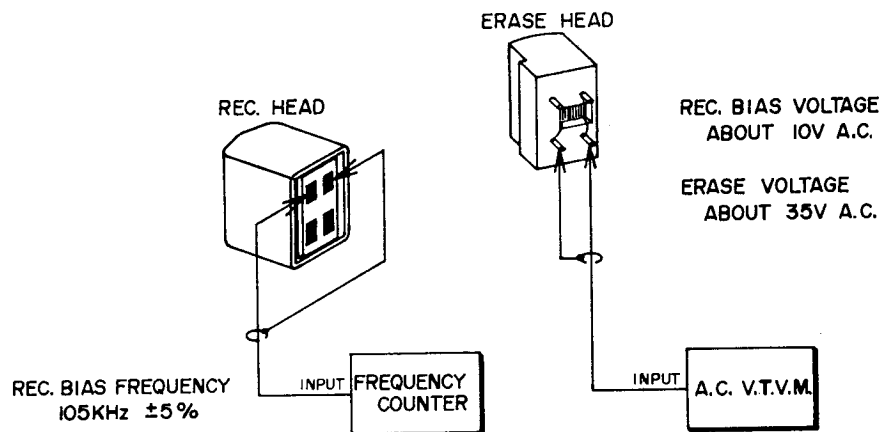

Fig. 22

Fig. 23

3. PRIOR TO ADJUSTMENT

Set the Various Amp. Panel Switches and Volumes as shown below prior to adjustment.

- 1) Dolby NR Switch: OFF
- 2) Monitor Switch: TAPE
- 3) S.O.S. Switch: NORMAL
- 4) Equalizer Switch: 7-1/2 ips.
- 5) Tape Selector: LOW NOISE
- 6) Mic Recording Volume: Minimum
- 7) Line Recording Volume: Maximum

4. PLAYBACK LEVEL ADJUSTMENT

(See Figs. 19, 20)

- 1) Playback a 250 Hz 7-1/2 ips. 0VU recorded test tape.
- 2) Adjust Pre-Amp. P.C. Board semi-fixed resistors VR4 20 k Ω (left channel) and VR4b 20 k Ω (right channel) shown in Fig. 20 to obtain a 0 dBm High Sensitivity V.T.V.M. indication.
- 3) VU Meter scales should register 0VU.

5. MONITOR LEVEL ADJUSTMENT

(See Fig. 20)

- 1) Supply a correctly determined 1,000 Hz 70 mV signal to the line input.
- 2) Set Monitor Switch to SOURCE.
- 3) Adjust Pre-Amp. P.C. Board semi-fixed resistors VR1 2 kB (left channel) and VR1b 2 kB (right channel) shown in Fig. 20 to obtain a 0 dBm High Sensitivity V.T.V.M. indication.
- 4) VU Meters should register 0VU.

6. RECORDING LEVEL ADJUSTMENT

USING LOW NOISE TAPE (See Fig. 20)

- 1) Load a Low Noise blank tape (Scotch #211)
- 2) Supply a correctly determined 1,000 Hz 70 mV signal to the line input.
- 3) Set Monitor Switch to TAPE position, and set deck to recording mode.
- 4) Adjust Pre-Amp. P.C. Board semi-fixed resistors VR2 10 kB (left channel) and VR2b 10 kB (right channel) to obtain a 0 dBm High Sensitivity V.T.V.M. indication.
- 5) VU Meters should register 0VU.

Caution: The Tape Selector must be set to LOW NOISE position.

7. RECORDING LEVEL ADJUSTMENT

USING WIDE RANGE TAPE (See Fig. 20)

- 1) Load a Wide Range blank tape (Akai SRT Tape).
- 2) Supply a correctly determined 1,000 Hz 70 mV signal to the line input.
- 3) Set Monitor Switch to TAPE position, set Tape Selector to WIDE RANGE, and set deck to recording mode.
- 4) Adjust Pre-Amp. P.C. Board semi-fixed resistors VR3 50 kB (left channel) and VR3b 50 kB (right channel) shown in Fig. 20 to obtain a -1 dBm High Sensitivity V.T.V.M. indication.
- 5) VU Meters should register -1VU.

8. FREQUENCY RESPONSE ADJUSTMENT

(Recording Bias Adjustment) (See Fig. 21)

- 1) Load a Low Noise blank tape (Scotch #211).
- 2) Supply a correctly determined 2,000 Hz 70 mV signal to the line input.
- 3) Set Various Switches to positions outlined in Section VII. Item 3.
- 4) Then, decrease the line input by 20 dB by adjusting the attenuator.
- 5) Set tape deck to recording mode.
- 6) Switch the oscillation frequency of the Audio Frequency Oscillator to and from 2,000 and 20,000 Hz and adjust Osc./Power Supply P.C. Board trimmer condensers C6 70P (left channel) and C7 70P (right channel) shown in Fig. 21 so that the difference in line output level between 2,000 and 20,000 Hz is 0.5 to 1.5 dB. (2,000 Hz/-20 dBm, 20,000 Hz/-19.5 to -18.5 dBm).

9. RECORDING BIAS FREQUENCY CHECK

Set deck to recording mode. Connect a Frequency Counter to the recording head terminals as shown in Fig. 22 and take a Frequency Counter reading.

10. RECORDING BIAS VOLTAGE AND ERASE VOLTAGE

Set deck to recording mode. Connect an A.C. Voltmeter to the erase head terminals as shown in Fig. 23 and take a Voltmeter reading. Then connect Voltmeter to Recording Head terminals and take a Voltmeter reading.

Caution: Use a High Frequency A.C. Voltmeter.

For Service Manuals Contact
MAURITRON TECHNICAL SERVICES
8 Cherry Tree Rd, Chinnor
Oxon OX9 4QY
Tel: 01844-351694 Fax: 01844-352554
Email: enquiries@mauritron.co.uk

VIII. DOLBY NR AMP. ADJUSTMENT

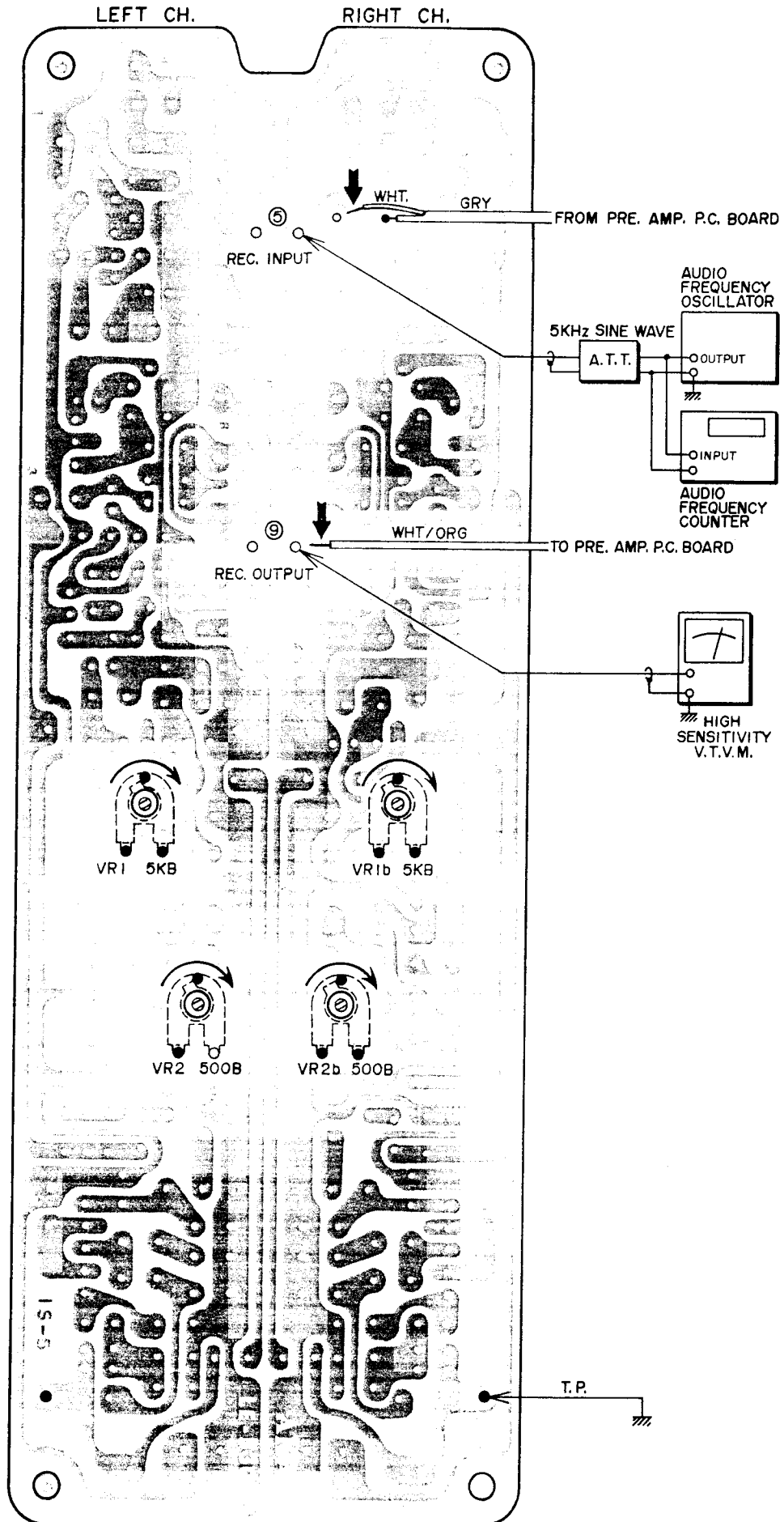

Fig. 24

For Service Manuals Contact
MAURITRON TECHNICAL SERVICES
 8 Cherry Tree Rd, Chinnor
 Oxon OX9 4QY
 Tel: 01844-351694 Fax: 01844-352554
 Email: enquiries@mauritron.co.uk

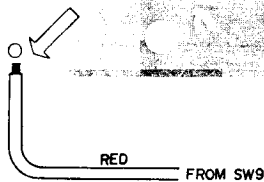

Fig. 25

1. RECORDING DOLBY NR CIRCUIT ADJUSTMENT (See Figs. 24 and 25)

Prior to adjustment, disconnect the wiring (indicated by arrow mark in Fig. 24) from Dolby Circuit recording input ⑤, and recording output ⑨. Then connect an Audio Frequency Oscillator to recording input ⑤ and connect a High Sensitivity V.T.V.M. to recording output ⑨.

* Because bias leak is influenced by this measurement, disconnect the wire indicated by the arrow mark in Fig. 25.

- Set deck to recording mode.
- Turn F.E.T. Gate Bias adjustment resistors VR1 5 kB and VR2 500B clockwise and set to maximum.
- Set Dolby Switch to OFF position, and ground test point.
- Supply a 5 kHz (-10 dBm) sine wave signal which has been correctly determined with a Frequency Counter, to the recording input 5 from the Audio Frequency Oscillator.
 At this time, confirm that the indication of the High Sensitivity V.T.V.M. connected to recording output ⑨ is 0 dBm.
- Next reduce the output of the Audio Frequency Oscillator by 30.5 dB by means of the Attenuator and set the input level to -40.5 dBm. At this time confirm that the indication of the High Sensitivity V.T.V.M. connected to recording output ⑨ is -30.5 dBm.

- Set the Dolby Switch to ON position and adjust semi-fixed resistor VR2 500B to obtain an output level of -20.5 dBm at output terminal ⑨.
- Next, disconnect ground from test point and adjust semi-fixed resistor VR1 5 kB to obtain an output level of -22.5 dBm at output terminal ⑨.

2. PLAYBACK DOLBY NR CIRCUIT CONFIRMATION

Connect all wires disconnected in Dolby Amp. Adjustment.

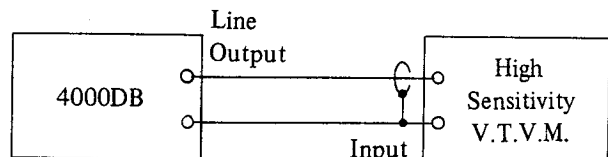

Fig. 26

- Connect a High Sensitivity V.T.V.M. as shown in Fig. 26.
- Set Dolby Switch to OFF position.
- Set Tape Monitor Switch to TAPE position.
- Playback a 5 kHz -25 dB 7-1/2 ips. pre-recorded test tape at 7-1/2 ips. (At this time the High Sensitivity V.T.V.M. indicates -25 dB±0.5 dB)
- Set Dolby Switch to ON position. At this time, the High Sensitivity V.T.V.M. indication should decrease by 10 dB (to -35 dB±0.5 dB).

NOTE: As precision adjustment is necessary, when making Dolby Amp. P.C. Board adjustments, try to use only precision instruments and set the various volumes accurately.

IX. DOLBY NOISE REDUCTION CIRCUIT OPERATION

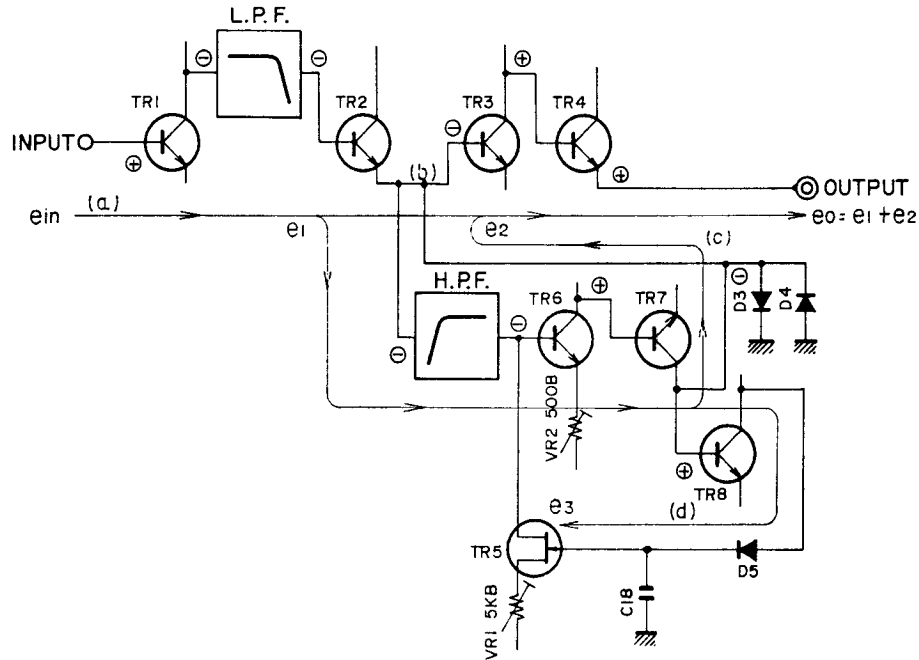

Fig. 27

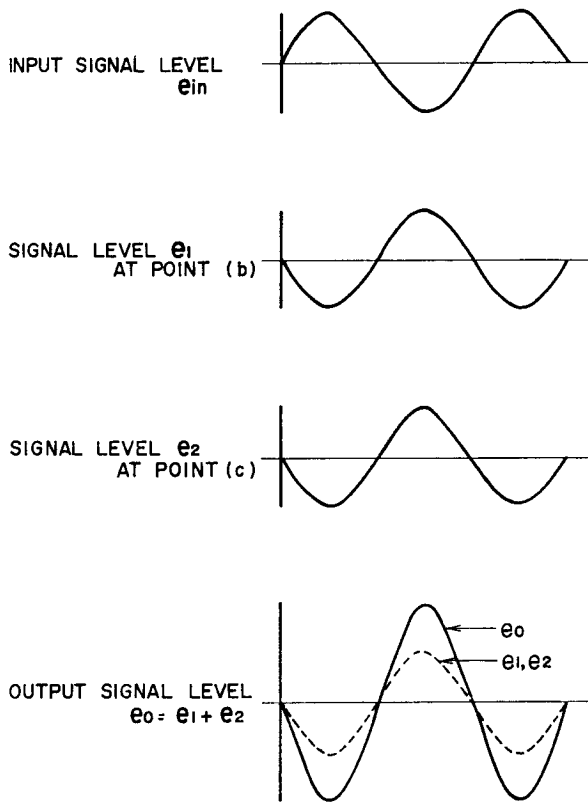

Fig. 28

1. RECORDING DOLBY NR CIRCUIT OPERATION (See Figs. 27 and 28)

- 1) As shown in Fig. 27, at recording time, the input signal passes TR1 and the low pass filter and is supplied to the base of TR2.
- 2) This signal is amplified at TR2 and the over 400 Hz frequency part of the signal emitted passes the high pass filter and is amplified at TR6 and TR7.
- 3) At this time, the signal which passes TR8 is rectified at D5 and supplied to TR5 F.E.T. Gate. This D.C. bias causes the F.E.T. to act as a variable resistor and change the impedance between the drain and source.
- 4) When this input signal is small, because TR5 (F.E.T.) has a certain impedance value which becomes like an electronic attenuator, the input signal supplied to the base of TR6 is controlled by F.E.T. and becomes e_1/k (k represents attenuator constant).

This signal is amplified at TR6 and TR7. If we let A represent the degree of amplification at this time, the output voltage at TR7 collector becomes:

$$e_2 = e_1/k \cdot A \dots \dots \text{(formula 1)}$$

- 5) Here, if we let m represent A/k , formula 1 becomes:

$$e_2 = m e_1 \dots \dots \text{(formula 2)}$$

For Service Manuals Contact
 MAURITRON TECHNICAL SERVICES
 8 Cherry Tree Rd, Chinnor
 Oxon OX9 4QY
 Tel: 01844-351694 Fax: 01844-352554
 Email: enquiries@mauritron.co.uk

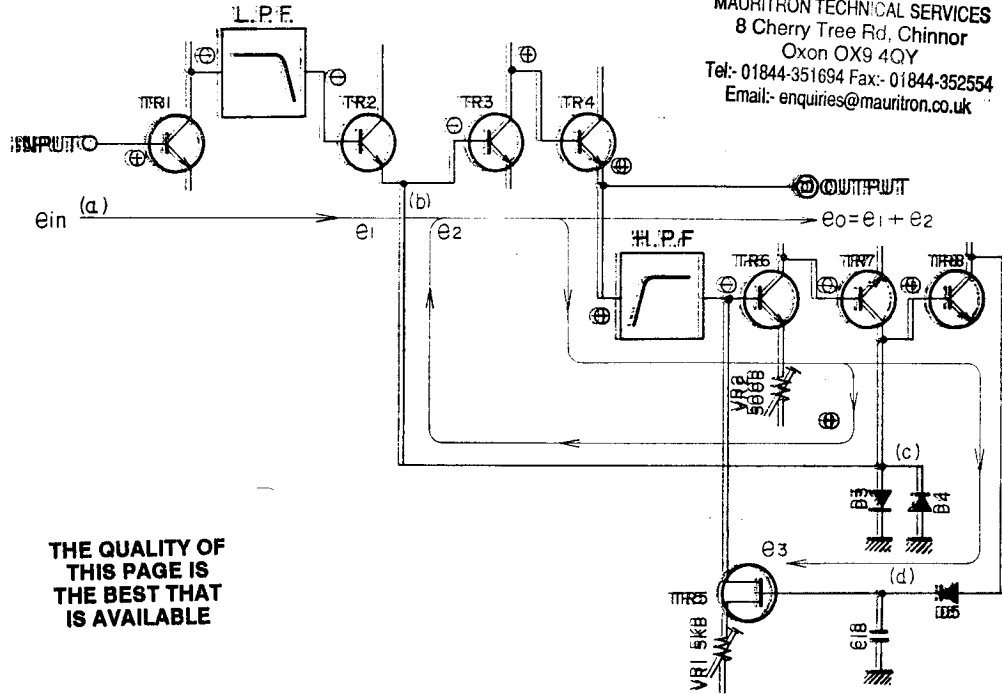

THE QUALITY OF
 THIS PAGE IS
 THE BEST THAT
 IS AVAILABLE

Fig. 29

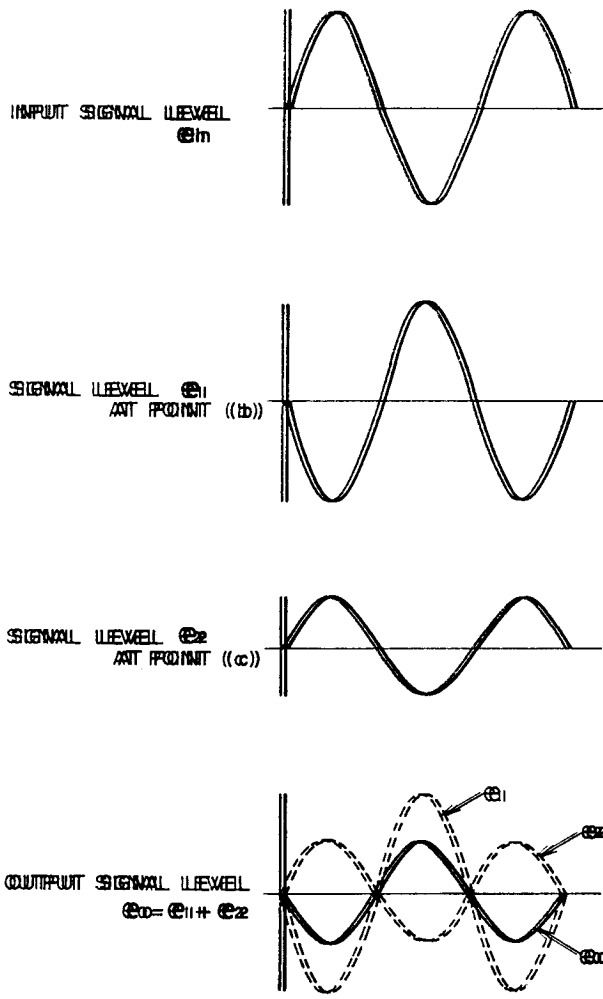

Fig. 30

Because e_o appearing at the output terminal is the composite signal of e_1 (TR2 output signal) and e_2 (the signal controlled by F.I.E.T. and which passed point c), e_o becomes:

$$e_o = e_1 + e_2 \dots \dots \dots \text{(formula 3)}$$

If we substitute formula 2 for formula 3

$$e_o = e_1 + m e_1 \dots \dots \dots \text{(formula 4)}$$

Further, at this time e_1 and $m e_1$ are in-phase at point (b). (See Fig. 28)

- 6) At the Dolby recording circuit, output signal e_o is recorded at a 10 dB higher level in relation to a 30 dB lower input level than the Dolby level (See Fig. 31) (Output signal e_o , at over 400 Hz signal, becomes 10 dB higher than the input signal).
- 7) When the input signal gradually becomes large, the D.C. Voltage which was amplified at TR8 and rectified at D5 also becomes larger. That is to say, the D.C. Bias of TR5 (F.I.E.T.) increases. When this happens TR5 (F.I.E.T.) impedance is attenuated. For this reason, e_1 signal level is greatly decreased by F.I.E.T. function before it is supplied to TR6 base. In other words, because the part of the signal which exceeds the 400 Hz dolby level is attenuated, the situation of $e_1 \gg m e_1$ develops. Therefore, $e_2 = m e_1$ can be disregarded.
- 8) Because the output signal becomes $e_o = e_1$, the relative ratio of the input and output signals become 1:1 (Fig. 31).

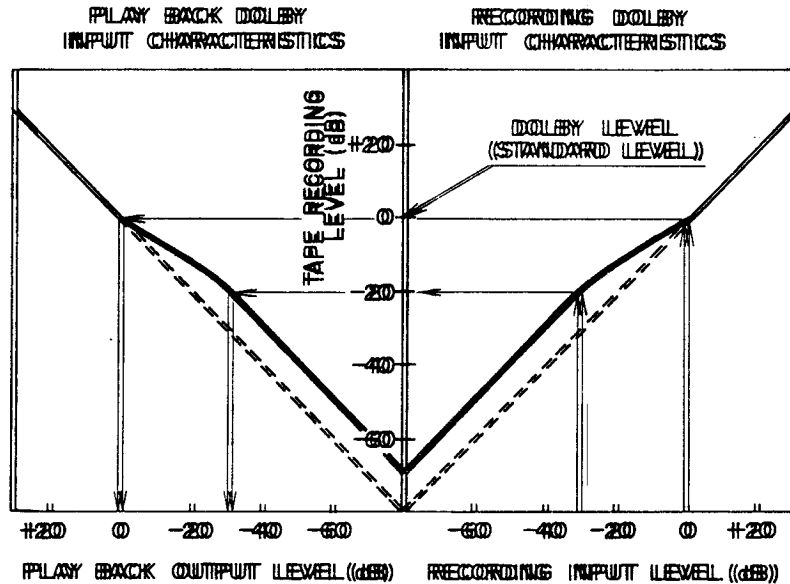

Fig. 31

2. PLAYBACK DOLBY NR CIRCUIT OPERATION (Figs. 29 and 30)

- 1) When the Dolbyized signal is played back, the input signal passes TR1 and the low pass filter and is amplified at TR2, TR3, TR4. TR4 output signal passes the high pass filter and is amplified at TR6 and TR7.
- 2) At this time the signal which passes TR3 is rectified at D5 and supplied to TR5 (F.E.T.) gate. D.C. Voltage e_3 which was rectified at D5 functions as TR5 (F.E.T.) D.C. Bias, the impedance between F.E.T. drain and source is changed, and the signal to TR6 base is controlled.
- 3) Signal e_2 appearing at point (c) is supplied as the reverse phase of TR2 output signal e_1 (See Fig. 30). At this time, the Dolbyized signal reverts to the original signal and the output signal becomes e_0 .
- 4) Expressed by a formula, this becomes:

$$e_0 = e_1 + (-e_2) \dots \dots \dots \text{(minus indicates reverse phase)}$$

$$= e_1 + (-ms_1) \dots \dots \text{(formula 5)}$$

- 5) As shown in Fig. 31, with the Playback Dolby NR Circuit signals recorded above the Dolby level are played back at a 1:1 ratio, and signals recorded at a level of under -20 dB on the tape (Dolbyized recorded signals) are reduced by 10 dB and played back.

At this time, because the noise level is also reduced by 10 dB, the S/N ratio is improved. Therefore the difference in function of Recording Dolby Circuit and Playback Dolby Circuit is in the phase relation of the signal supplied to point (b).

THE QUALITY OF THIS PAGE IS THE BEST THAT IS AVAILABLE

X. COMPOSITE VIEWS OF COMPONENTS

1. PRE AMP. P.C. BOARD LE-5306

For Service Manuals Contact
MAURITRON TECHNICAL SERVICES
 8 Cherry Tree Rd, Chinnor
 Oxon OX9 4QY
 Tel:- 01844-351694 Fax:- 01844-352554
 Email:- enquiries@mauritron.co.uk

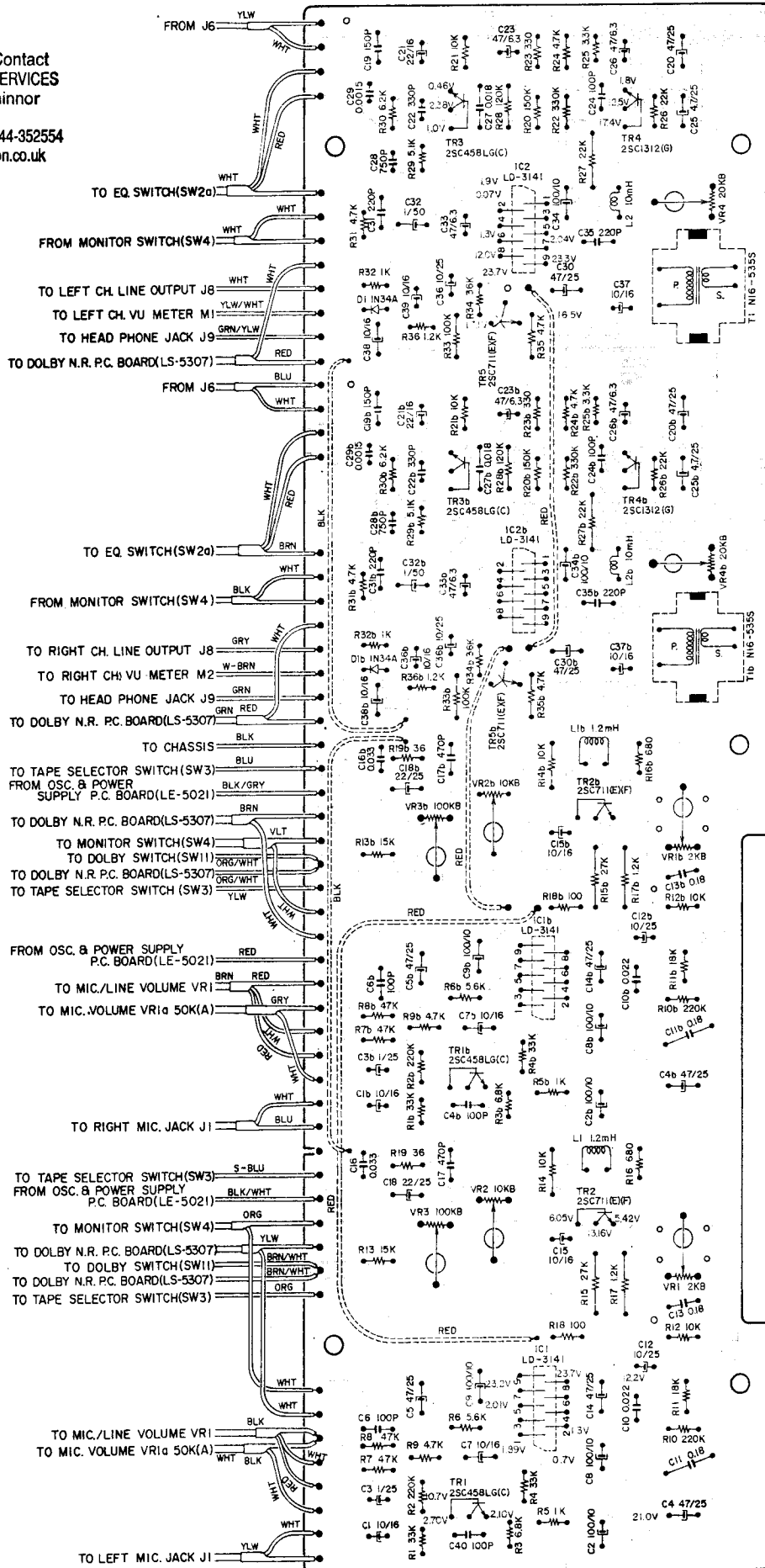

2. DOLBY NR. P.C. BOARD LE-5307

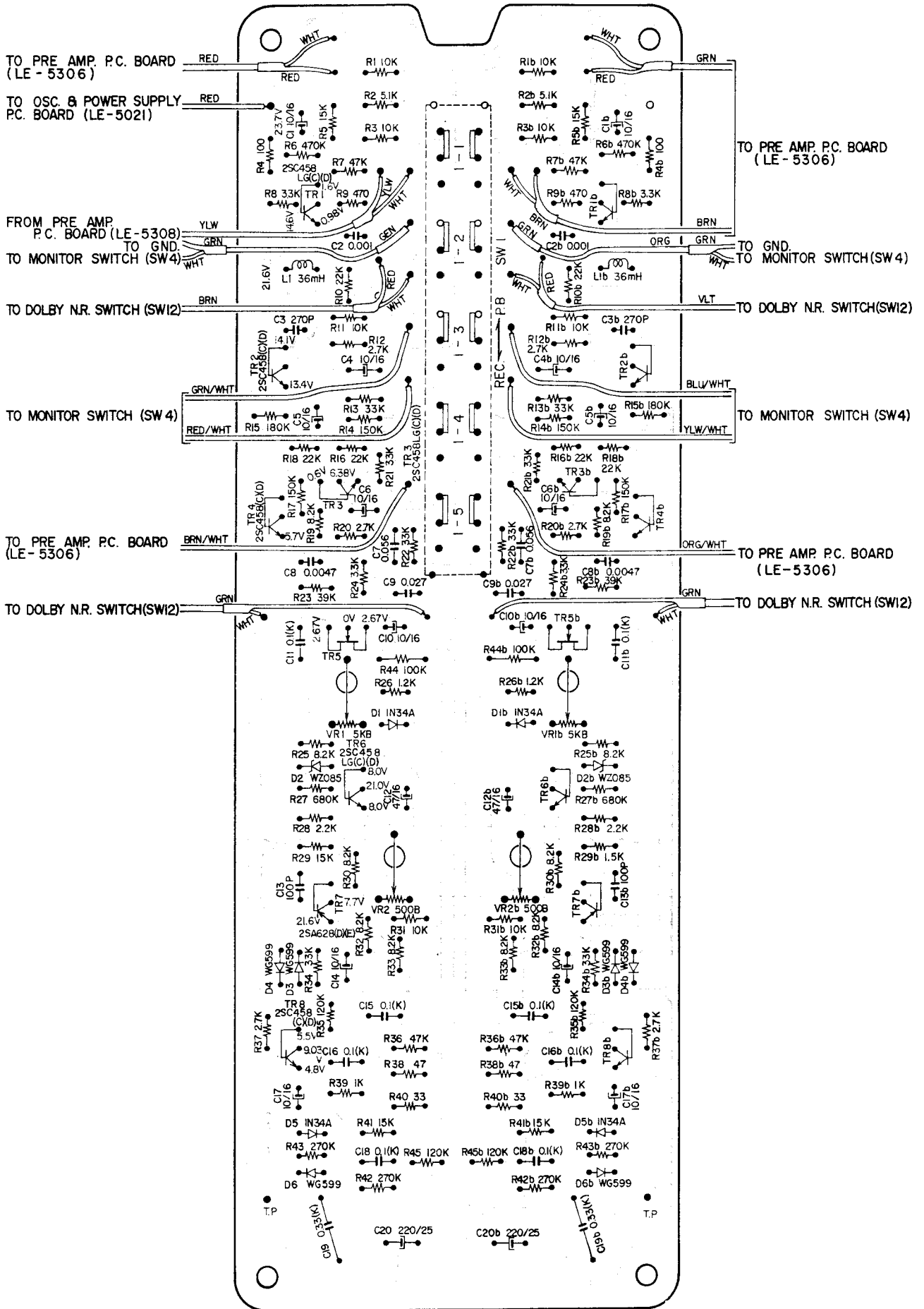

3. OSC. & POWER SUPPLY P.C. BOARD LE-5021

THE QUALITY OF
THIS PAGE IS
THE BEST THAT
IS AVAILABLE

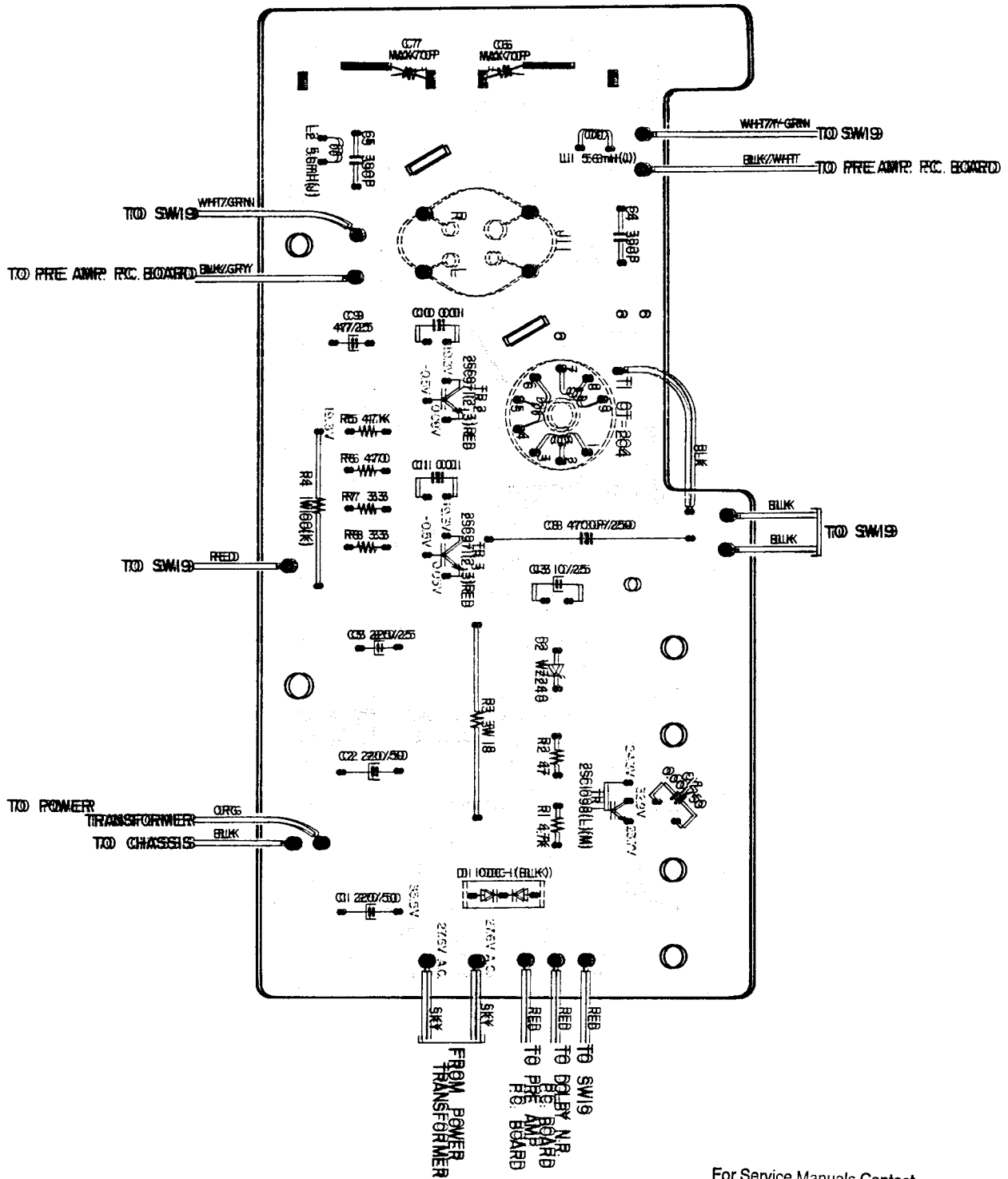

For Service Manuals Contact
MAURITRON TECHNICAL SERVICES
8 Cherry Tree Rd, Chinnor
Oxon OX9 4QY
Tel: 01844-351694 Fax: 01844-352554
Email: enquiries@mauritron.co.uk

THE QUALITY OF
THIS PAGE IS
THE BEST THAT
IS AVAILABLE

SECTION 2

PARTS LIST

TABLE OF CONTENTS

FIG. 1	HEAD BLOCK	31
FIG. 2	REEL TABLE BLOCK	31
FIG. 3	MOTOR BLOCK	33
FIG. 4	FLYWHEEL/BELT CHANGE LEVER BLOCK	34
FIG. 5	SWITCH BLOCK	35
FIG. 6	MECH. ASSEMBLY BLOCK	37
FIG. 7	PRE-AMP. P.C. BOARD (LE-5306) BLOCK	38
FIG. 8	OSC. POWER SUPPLY P.C. BOARD (LE-5021) BLOCK	39
FIG. 9	DOLBY P.C. BOARD (LE-5307) BLOCK	41
FIG. 10	AMP. ASSEMBLY BLOCK	42
FIG. 11	FINAL ASSEMBLY BLOCK	45

HOW TO USE THIS PARTS LIST

1. This parts list is compiled by various individual blocks based on assembly process.
2. When ordering parts, please describe parts number, serial number, and model number in detail.
3. How to read List

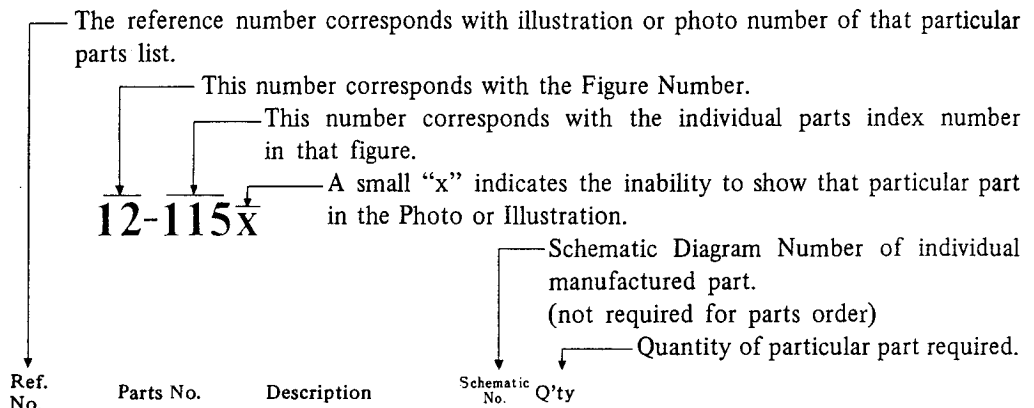

Ref. No.	Parts No.	Description	Schematic No.	Q'ty
FLYWHEEL BLOCK #13				
12-115x	800425	Flywheel Block Assy. Comp.	RDG #13	1
12-116	244506	Flywheel Only	RD-233	1
12-117x	244754	Felt, Flywheel	RD-275	1
12-118	251324	Main Metal Case	RD-236	1
12-119	253080	Main Metal	RD-237	1

4. The symbol numbers shown on the P.C. Board list can be matched with the Composite Views of Components of the Schematic Diagram or Service Manual.
5. The indications of Resistors and Capacitors in the photos of P.C. Board are being eliminated.
6. The shape of the parts and parts name, etc. can be confirmed by comparing them with the parts shown on the Electrical Parts Table of P.C. Board.
7. Both the kind of part and installation position can be determined by the Parts Number. To determine where a parts number is listed, utilize Parts Index at end of Parts List.
It is necessary first of all to find the Parts Number. This can be accomplished by using the Reference Number listed at right of parts number in the Parts Index. (meaning of ref. no. outlined in Item 3 above).
8. Utilize separate "Price List for Parts" to determine unit price. The most simple method of finding parts Price is to utilize the reference number.

For Service Manuals Contact
MAURITRON TECHNICAL SERVICES
 8 Cherry Tree Rd, Chinnor
 Oxon OX9 4QY
 Tel:- 01844-351694 Fax:- 01844-352554
 Email:- enquiries@mauritron.co.uk

ELECTRICAL PARTS TABLE



<p>Because the indication of resistors and capacitors in the P.C. Board photos are being eliminated, please confirm parts name and shape by comparing them with the parts shown in this table.</p>	<p style="text-align: center;">1</p>  <p style="text-align: center;">Solid Resistor</p>	<p style="text-align: center;">2</p> <p style="text-align: right;">Stopper Type</p>  <p style="text-align: center;">Insulator Type</p> <p style="text-align: center;">Carbon Resistor</p>	<p style="text-align: center;">3</p>  <p style="text-align: center;">Metal Oxide Film Resistor</p>
<p style="text-align: center;">4</p>  <p style="text-align: center;">Cement Resistor</p>	<p style="text-align: center;">5</p>  <p style="text-align: center;">Wire-Wound Resistor</p>	<p style="text-align: center;">6</p>  <p style="text-align: center;">Thermister</p>	<p style="text-align: center;">7</p>  <p style="text-align: center;">Enamel Resistor</p>
<p style="text-align: center;">1</p>  <p style="text-align: center;">MP Capacitor (Tubular Type)</p>	<p style="text-align: center;">2</p>  <p style="text-align: center;">Plastic Capacitor</p>	<p style="text-align: center;">3</p>  <p style="text-align: center;">Mylar Capacitor</p>	<p style="text-align: center;">4</p>  <p style="text-align: center;">VFM (Hi-Q) Capacitor</p>
<p style="text-align: center;">5</p>  <p style="text-align: center;">Mylar Capacitor</p>	<p style="text-align: center;">6</p>  <p style="text-align: center;">Tantalum Capacitor</p>	<p style="text-align: center;">7</p>  <p style="text-align: center;">Oil Capacitor (Tubular Type)</p>	<p style="text-align: center;">8</p> <p style="text-align: right;">Vertical Type</p>  <p style="text-align: center;">Tubular Type</p> <p style="text-align: center;">Styrol Capacitor</p>
<p style="text-align: center;">9</p>  <p style="text-align: center;">Electrolytic Capacitor (Tubular Type)</p>	<p style="text-align: center;">10</p> <p style="text-align: right;">Vertical Type</p>  <p style="text-align: center;">Tubular Type</p> <p style="text-align: center;">Electrolytic Capacitor</p>	<p style="text-align: center;">11</p>  <p style="text-align: center;">Ceramic Capacitor</p>	<p style="text-align: center;">12</p>  <p style="text-align: center;">Metalized Mylar (Paper) Capacitor</p>
<p style="text-align: center;">13</p>  <p style="text-align: center;">Trimmer Condenser</p>		<p style="text-align: center;">VR</p>  <p style="text-align: center;">Semi-Fixed Volume</p>	
<p style="text-align: center;">L</p>  <p style="text-align: center;">Ferri Inductor</p>	<p style="text-align: center;">TR</p>  <p style="text-align: center;">Transistor</p>		
<p style="text-align: center;">CR</p>  <p style="text-align: center;">Spark Quencher</p>	<p style="text-align: center;">D</p>  <p style="text-align: center;">Diode (Silicon, Zener, Germanium)</p>		

FIG. 1 ILLUSTRATION OF HEAD BLOCK



For Service Manuals Contact
MAURITRON TECHNICAL SERVICES
 8 Cherry Tree Rd, Chinnor
 Oxon OX9 4QY
 Tel: 01844-351694 Fax: 01844-352554
 Email: enquiries@mauritron.co.uk

HEAD BLOCK

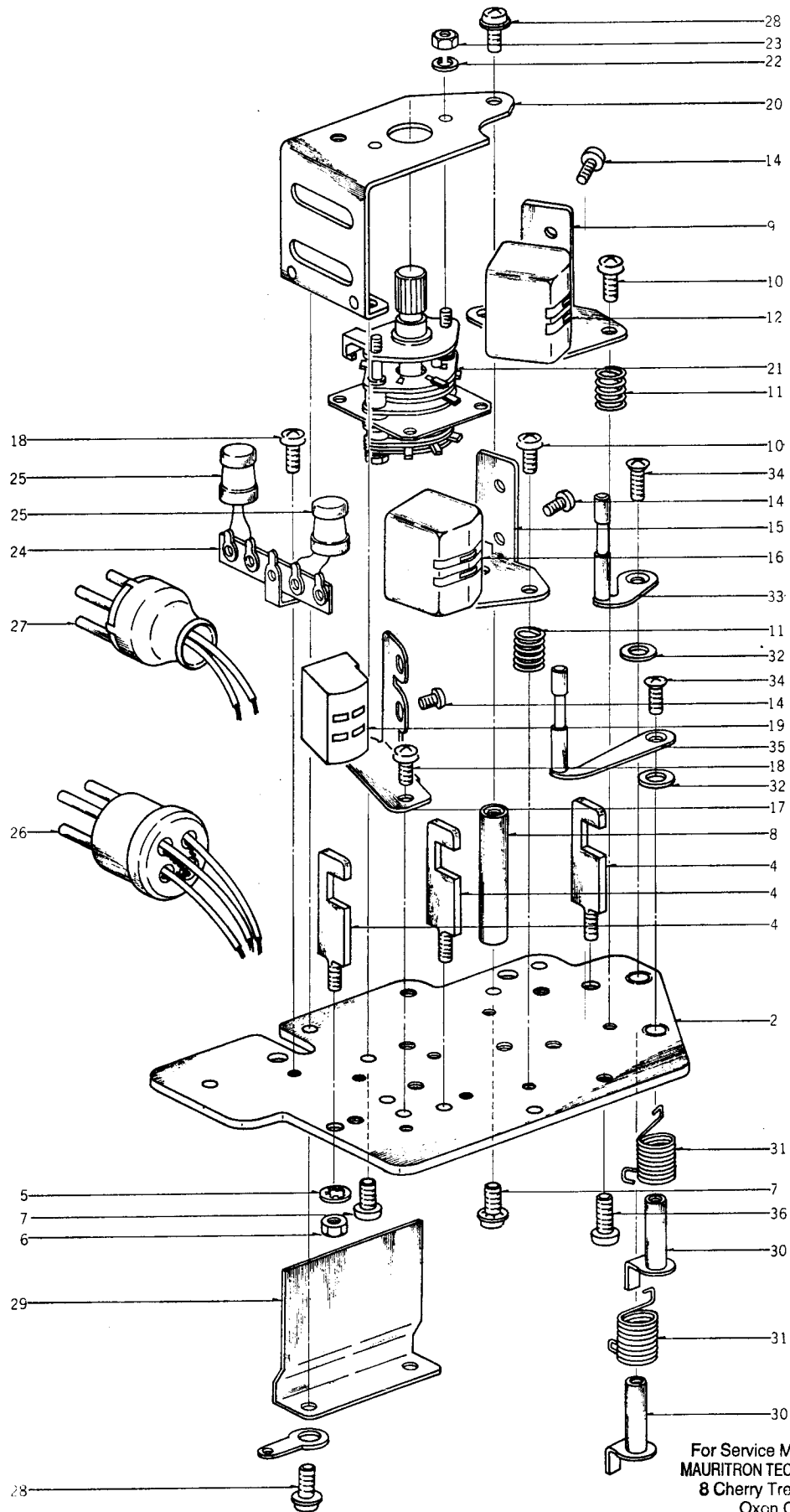
Ref. No.	Parts No.	Description	Schematic No.	Q'ty
1-1x	BH480363	Head Block Comp.	LE-3	1
1-2	HZ490296	Head Base, B, (New LD), w/metal	LD-11	1
1-3x	MH605856	Head Cover Prop B	LE-0007	2
1-4	HZ274162	Tape Guide #1	4TR-5	3
1-5	ZW273802	Toothed Lock Washer M3		3
1-6	ZW516611	Nut M3		3
1-7	ZS322626	ISO Screw, binding head 3x8, w/washer		2
1-8	MH312827	SW. Prop (New LD)	LD-13	1
1-9	HZ480420	PB. Angle Base	LE-0001	1
1-10	ZS464714	Screw, round head 3x12		3
1-11	ZG206144	Angle Adjust Spring	RD-16	6
1-12	HP375131	REC./PB. HEAD P4-150		1
1-13x	HZ393974	I-MK Head Terminal Plate	RC-89	2
1-14	ZS201475	Screw, pan head 2x3		6
1-15	HZ480431	Rec. Angle Table	LE-0002	1
1-16	HP475446	REC. HEAD P4-154		1
1-17	HZ480442	Erase Head Base	LE-0003	1
1-18	ZS323728	Screw, binding head 3x5		3
1-19	HE384693	ERASE HEAD E4-200		1
1-20	HZ312895	SW. Table (New LD)	LD-12	1
1-21	ES257668	Rotary SW. ESR-E263L14AS	25-6-3	1
1-22	ZW273723	Spring Washer M2		2
1-23	ZW273734	Nut M2		2
1-24	EJ255115	Lug Plate VB2L2	33-4-3	1
1-25	EO390622	Ferri Inductor PL9H 220μH (K)	23-1-4	2
1-26	EJ297843	Plug 4P, w/cap	42-1-3	1
1-27	EJ276963	Plug 4P (T Type)	42-1-16	1
1-28	ZS349288	ISO Screw, binding head 3x5, w/washer		1
1-29	HZ480475	Head Shield	LE-0004	1
1-30	HL223503	Shift Lever B, w/shaft A	M9-3	2
1-31	ZG312928	Shifter Spring	LD-19	2
1-32	ZW336846	Washer (SPC) D4.1x7x1.2t		2
1-33	HL312941	Shift Lever, w/pin	LD-15	1
1-34	ZS480622	Screw, oval countersunk head 2.3x6		2
1-35	HL223536	Shift Lever C, w/pin	M9-5	1
1-36	ZS379405	ISO Screw, binding head 3x6		1

REEL TABLE BLOCK

Ref. No.	Parts No.	Description	Schematic No.	Q'ty
2-1x	BR589206	Supply Reel Table Block		
		Comp.	LE-3	1
2-2	BR589217	Take-up Reel Table Block		
		Comp.	LE-3	1
2-3	MT368684	Reel Table Disk A, w/shaft A	XR-101	2
2-4x	MT252112	Friction Cloth B	900-225	2
2-5	MT317463	Reel Table Rubber, MR	MR-250	2
2-6	MS255600	Reel Shaft B	XR-103	2
2-7	MT516565	'O' Ring	3R-139	2
2-8	MT255420	Reel Retainer	3R-102	2
2-9	ZG255633	Reel Spring	3R-109	2
2-10	MT255565	Reel Shaft Ring	XR-177	2
2-11	ZW270088	'E' Ring 1.9M	6-1-9	2
2-12	MR251460	Rewind Pulley	900-222	1
2-13	MT222366	Rubber Ring	900-234	1
2-14	ZG227553	Spring G-2(L)	900-230	1
2-15	ZW260021	Washer (SUP) D6.1x10x0.13t		6
2-16	ZW260054	Washer (SUP) D6.1x10x0.25t		5
2-17x	ZW260065	Washer (SUP) D6.1x10x0.35t		6
2-18x	ZW260098	Washer (SUP) D6.1x10x0.5t		5
2-19	MT255870	Reel Table Thrust Retainer Pin	900-237	4
2-20x	MT252101	Friction Cloth A	900-224	2
2-21	MR252066	Take-up Roller C	900-220	1
2-22	MT255971	Reel Table Spring Plate A	900-227	1
2-23	MT438647	Reel Torque Adjust Thrust 7 D6.2x13x0.5t	101022	2
2-24	MT438636	Reel Torque Adjust Thrust 6 D6.2x13x1t	101021	3
2-25	MT438592	Reel Torque Adjust Thrust 2 D6.1x10x0.3t	101017	2
2-26	MT438603	Reel Torque Adjust Thrust 3 D6.1x10x0.5t	101018	2
2-27x	MT438625	Reel Torque Adjust Thrust 5 D6.1x10x1t	101020	3
2-28	ZW231693	Thrust Washer, w/claw	900-235	2
2-29	MT292386	Reel Metal Mt. Parts, XR, w/metal B	XR-191	2
2-30	ZW437804	Flywheel Thrust A D7.9x13x1t	101024	1
2-31	MT255993	Reel Table Spring Plate C	M8-207	1
2-32	ZW588306	Washer D6.1x10x0.35t		1
2-33	MH270000	Retaining Pin D4	900-257	1
2-34	MR256094	Reel Table Pulley (Counter)	900-239	1
2-35	ZS434171	Set Screw, hexagon socket 4x7 (cup/p)		1
2-36	MR252044	Take-up Roller A	900-218	1
2-37x	ZG227542	Spring G-2 (R)	900-230	1
2-38	MR252055	Take-up Roller B	900-219	1
2-39x	MT255982	Reel Table Spring Plate B	900-228	1
2-40x	MT438581	Reel Torque Adjust Thrust 1 D5.8x10.3x1t	101016	1
2-41	MT438614	Reel Torque Adjust Thrust 4 D6.1x10x0.8t	101019	1
2-42	ZW312693	'E' Ring 4M	6-1-4	1
2-43	ZG414077	Spring F-4	CD-67	1
2-44	MT440313	Nylon Tube 19M		1
2-45	MT228598	Set Sleeve B	CD-66	1
2-46	ZS434160	Set Screw, hexagon socket 3x3 (cup/p.)		1

When ordering parts, please describe Parts Number, Serial Number, and Model Number in detail.

FIG. 2 ILLUSTRATION OF REEL TABLE BLOCK

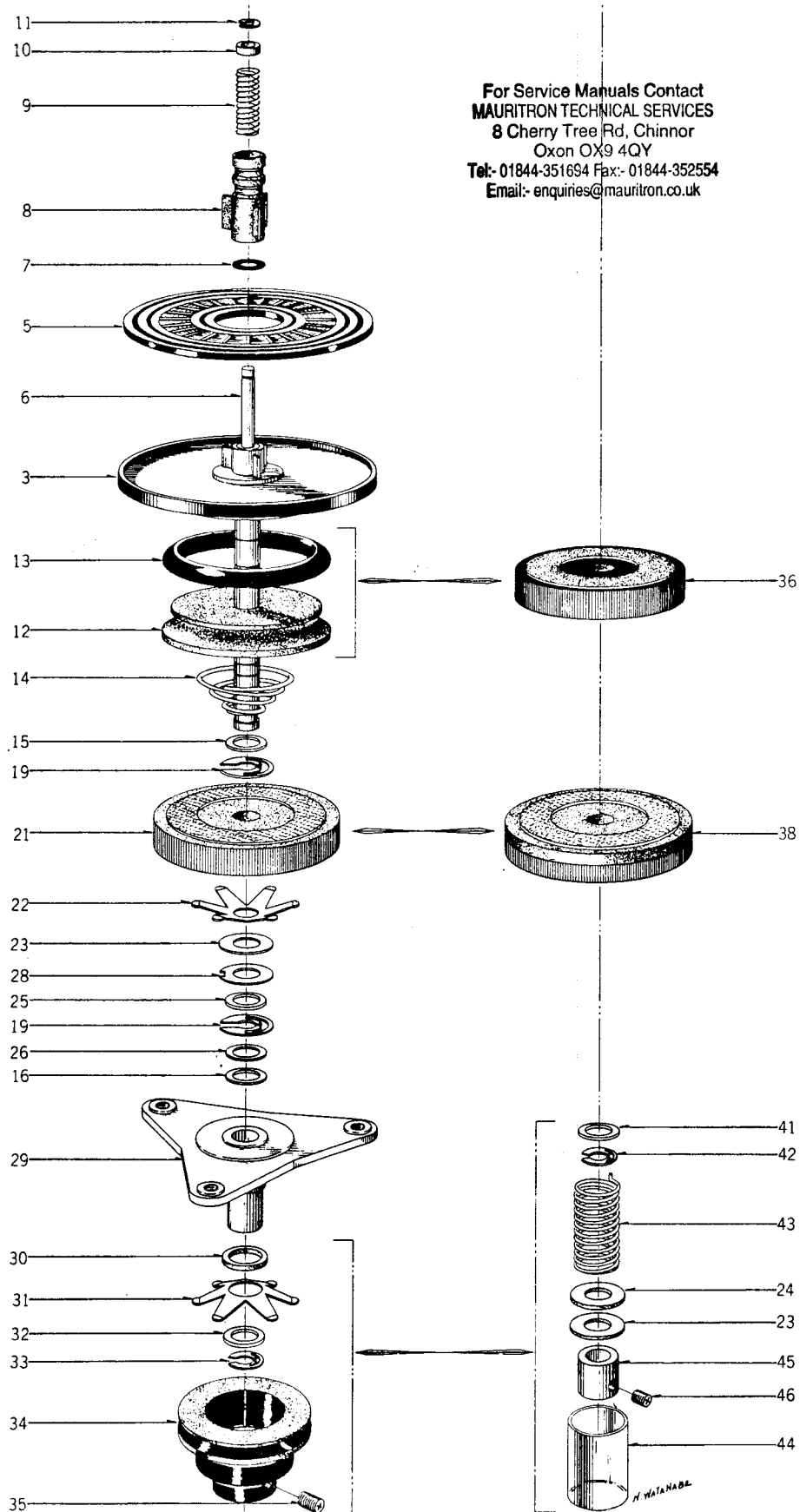

For Service Manuals Contact
MAURITRON TECHNICAL SERVICES
 8 Cherry Tree Rd, Chinnor
 Oxon OX9 4QY
 Tel:- 01844-351694 Fax:- 01844-352554
 Email:- enquiries@mauritron.co.uk

FIG. 3 ILLUSTRATION OF MOTOR BLOCK

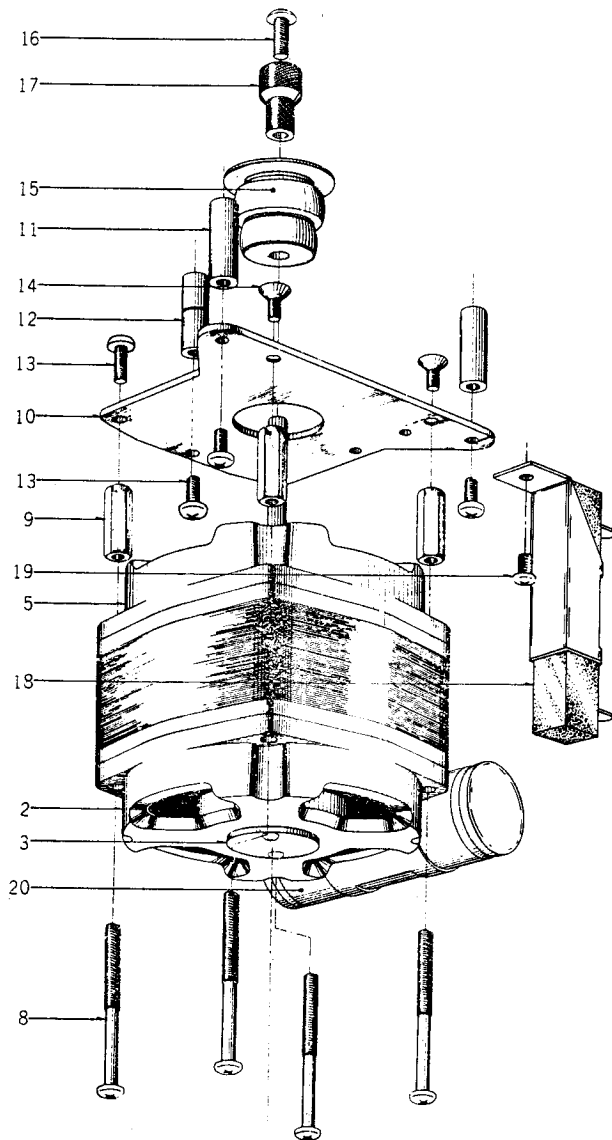

MOTOR BLOCK

Ref. No.	Parts No.	Description	Schematic No.	Q'ty
3-1x	BM601020	Motor Block Comp.	LE-3	1
3-2	MZ395144	Motor Cover B (900), w/metal	900-709	1
3-3	UC254250	Motor Bottom Plate	900-721	1
3-4x	ZS384131	Screw, round head 3x5		2
3-5	MZ395166	Motor Cover A(900), w/metal	900-707	1
3-6x	MZ253956	Motor Oil Cap D	900-725	1
3-7x	EZ335204	Felt C D14x19x4t	900-744	1
3-8	ZS427037	Screw, pan head 4x50, w/washer		4
3-9	ZW254621	Motor Hexagon Nut	900-737	4
3-10	MZ254351	Motor Mt. Plate A	900-738	1
3-11	MH254160	Motor Prop A	24X-730	2
3-12	MH254182	Motor Prop B	24X-731	1
3-13	ZS424056	Screw, pan head 4x10		7
3-14	ZS427026	Screw, countersunk head 4x10		2
3-15	MR254496	Motor Pulley	SRA-5	1
3-16	ZS600816	Screw, truss head 4x8		1
3-17	MR300644	Knurling Pulley (900 Type)	900-735	1
3-18	ER339805	Cement/R. H20B 450Ω(K)	35-16-16	1
3-19	ZS349288	ISO Screw, binding head 3x5, w/washer		3
3-20	EC410016	MP/C. 2+0.5μF 300V AC (Lug Type Uni/D.) (CEE)	24-9-13	1
3-21x	EC493525	MP/C. 2μF 250V AC (Lug Type Op/D.) (CSA)	24-9-65	1

When ordering parts, please describe Parts Number, Serial Number, and Model Number in detail.

FIG. 4 ILLUSTRATION OF FLYWHEEL/BELT CHANGE LEVER BLOCK

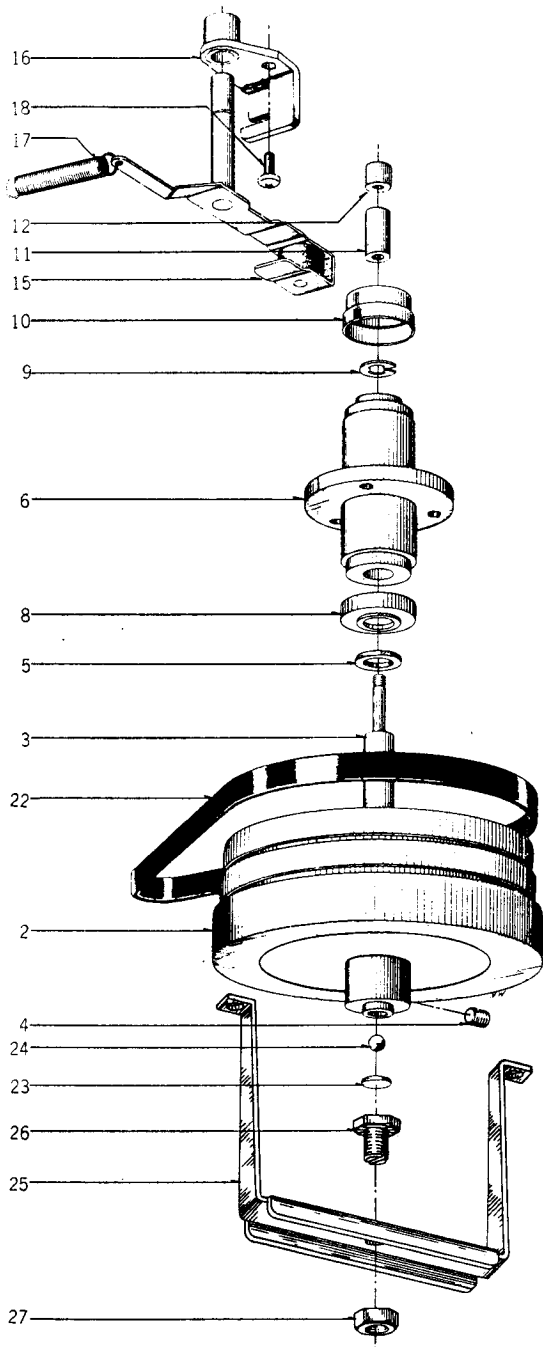

For Service Manuals Contact
MAURITRON TECHNICAL SERVICES
 8 Cherry Tree Rd, Chinnor
 Oxon OX9 4QY
 Tel:- 01844-351694 Fax:- 01844-352554
 Email:- enquiries@mauritron.co.uk

FLYWHEEL/BELT CHANGE LEVER BLOCK

Ref. No.	Parts No.	Description	Schematic No.	Q'ty
FLYWHEEL BLOCK				
4-1x	BF205075	Flywheel Block Comp.	LE-3	1
4-2	MI244473	Flywheel	707-S-10	1
4-3	MS244708	Flywheel Shaft	SRA-21	1
4-4	ZS373577	Set Screw, hexagon socket 5x6 (Flat/p.)		2
4-5	ZW447208	Flywheel Thrust B D7 9x13x0.5t	101025	1
4-6	MZ296267	Main Case B 24 Comp.	1630-205	1
4-7x	MZ586798	Main Case Felt	A0415	1
4-8	MZ446635	Thrust Cap, Main Metal B2	LE-2006	1
4-9	MH244710	Flywheel Fixing Pin	900-250	1
4-10	MZ253113	Main Metal Cap B	MH-208	1
4-11	MY270055	Capstan D8	SRA-7	1
4-12	ZS293027	Capstan Screw, 1100	SRA-6B	1
4-13x	ZW252977	Main Shaft Collar	SRA-32	1
BELT CHANGE LEVER BLOCK				
4-14x	BL564107	Belt Change Lever Block Comp.	LE-3	1
4-15	ML217462	Belt Change Lever B (Small), w/roller B	AT-25	1
4-16	MZ248354	Belt Guide Stop, w/metal	4TR-221	1
4-17	ZG465478	Brake Lever Spring	KD-1092	1
4-18	ZS417150	Screw, pan head 4x6		1
4-19x	ZG217394	Belt Change Spring B	MH-125	1
4-20x	ZW260054	Washer (SUP) D6.1x10x0.25t		1
4-21x	ZW290283	'U' Ring 2.85M	6-1-1	1
4-22	MH256601	Double Face Flat Belt D=110	100912	1
4-23	ZW235585	Nylon Plate D8		1
4-24	MV269965	Steel Ball D4		1
4-25	MZ585911	Shaft Supporting Plate	LS-1204	1
4-26	MZ585900	Shaft Support	LS-1203	1
4-27	ZW463410	ISO Nut #3 M5		1
4-28x	ZS419736	Screw, binding head 4x6		1

When ordering parts, please describe Parts Number, Serial Number, and Model Number in detail.

FIG. 5 ILLUSTRATION OF SWITCH BLOCK

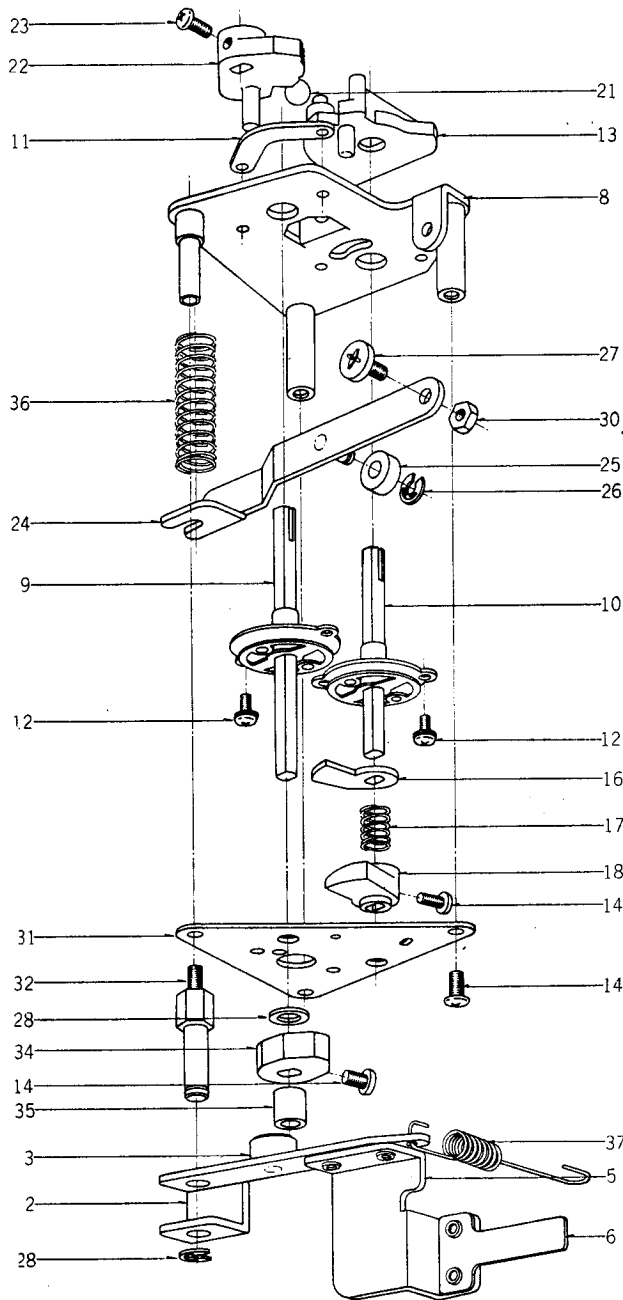

SWITCH BLOCK

Ref. No.	Parts No.	Description	Schematic No.	Q'ty
SW. LEVER BLOCK				
5-1x	BL588701	SW. Lever Block Comp.	LE-3	1
5-2	ML488744	Rec. Lever C, w/shaft B	LE-2002	1
5-3	MR269728	Cam Roller D12.5	RC-126	1
5-4x	ZW290283	'U' Ring 2.85M	6-1-1	1
5-5	ML582355	Switch Lever A, w/lever B	LE-1302	1
5-6	ML582366	Switch Lever B	LE-1303	1
SW. BLOCK				
5-7x	BS480352	SW. Block Comp.	LE-3	1
5-8	MZ316901	SW. Table A-2 (SX), w/props	MR-201	1
5-9	ES316934	Rewind Shaft (Y Type)	25-8-5	1
5-10	ES369865	Rewind Shaft (RCC-Y Type)	RCC-202	1
5-11	MZ316945	Nut Plate	MR-245	2
5-12	ZS413728	Screw, binding head 3x6, w/washer		4
5-13	MZ316956	Cam A-3	MR-242	1
5-14	ZS413201	Screw, pan head 4x8		5
5-15x	ZW260133	Washer (Fiber) D6.1x10x1t		2
5-16	MZ327341	Cam Trap Plate B	SX-201	1
5-17	ZG227586	Spring K	900-214	1
5-18	MZ327352	Cam C-2	SX202	1
5-19x	ZW434215	Washer (Nylon) D6.1x10.3x0.3t		1
5-20x	ZW434193	Washer (Nylon) D6.1x10.3x0.5t		1
5-21	MV270066	Steel Ball D8		1
5-22	MZ217293	Cam B-2 (Without Tap)	1630-201	1
5-23	ZS416687	Screw, binding head 4x8		1
5-24	ML257128	Lever I, w/shaft B	900-209	1
5-25	MR217203	Cam Roller A (Nylon) D12	900-153	1
5-26	ZW290283	'U' Ring 2.85M	6-1-1	2
5-27	ZS217877	Pause Lever Set Screw	900-136	1
5-28	ZW432347	Washer (Luminar) D6.2x13x0.125t		1
5-29x	ZW273892	Toothed Lock Washer M4		1
5-30	ZW273960	Nut M4		1
5-31	MZ225720	SW. Table B-2	M9-308	1
5-32	MH258581	Rec. Lever Prop	M9-303	1
5-33x	ZW260122	Washer (Nylon) D6.1x10x1t		1
5-34	MZ317068	Amp. SW. Cam B	MR-243	1
5-35	MZ610457	Pause Lever Cushion	LE-1005	1
5-36	ZG227485	Spring E	900-119	1
5-37	SZ493042	Rec. Wire B	LE-6028	1

When ordering parts, please describe Parts Number, Serial Number, and Model Number in detail.

FIG. 6 ILLUSTRATION OF MECH. ASSEMBLY BLOCK

For Service Manuals Contact
MAURITRON TECHNICAL SERVICES
 8 Cherry Tree Rd, Chinnor
 Oxon OX9 4QY
 Tel:- 01844-351694 Fax:- 01844-352554
 Email:- enquiries@mauritron.co.uk

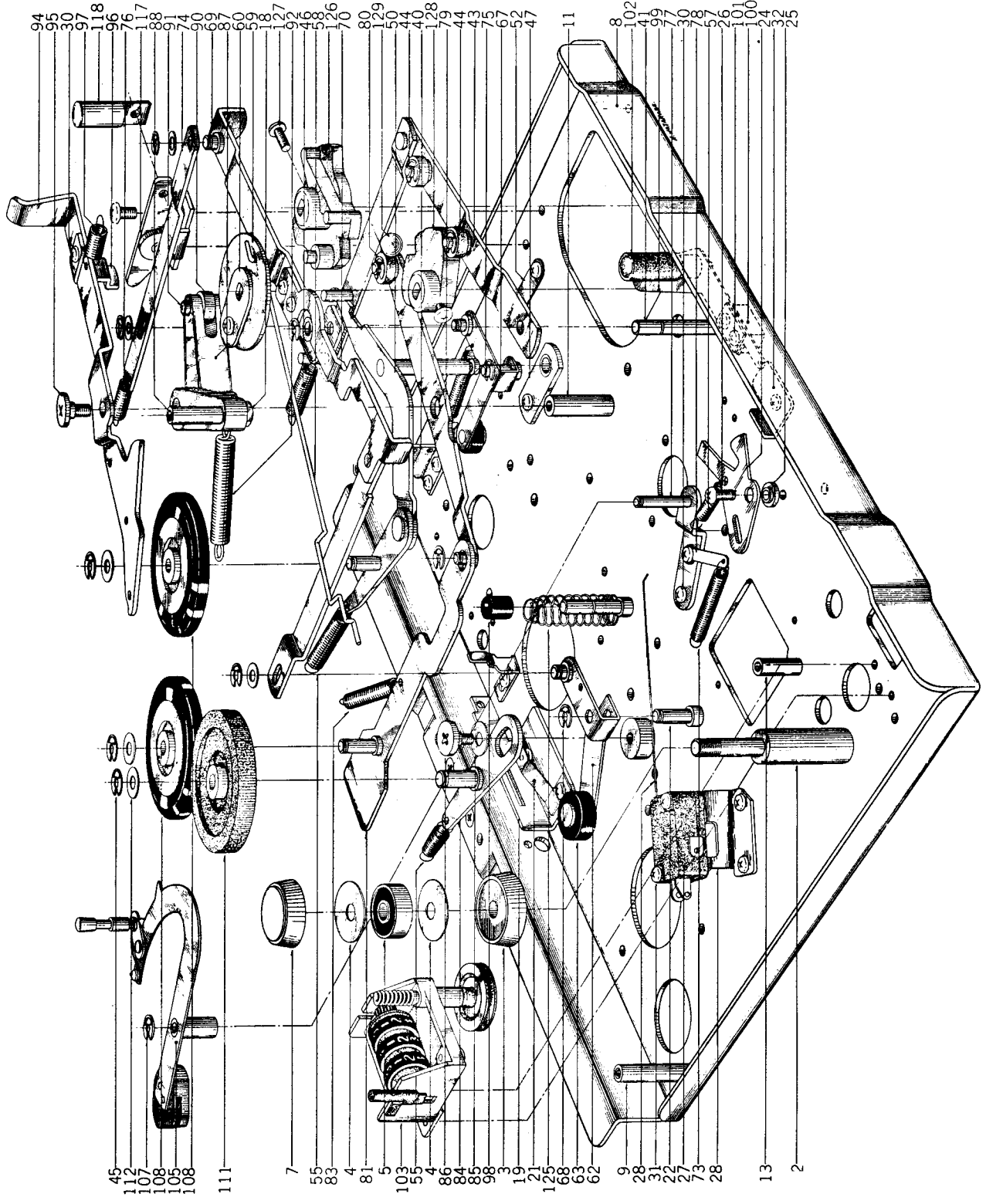

MECH. ASSEMBLY BLOCK

Ref. No.	Parts No.	Description	Schematic No.	Q'ty
TAPE GUIDE BLOCK				
6-1x	BZ400948	Tape Guide Block Comp.		1
6-2	MH204311	Tape Guide Prop #1700	AT-16	1
6-3	SZ465377	Tape Guide Table A	LC-618	1
6-4	ZW231805	Tape Guide Washer (Large)	3A-356	2
6-5	MV248117	Bearing SSR1950ZZSD52		1
6-6x	ZW274048	Nut M5		1
6-7	SZ465388	Tape Guide Table B	LC-619	1
MECH. ASSEMBLY BLOCK				
6-8	MZ271776	Mech. Frame (LD), w/bush	LD-101	1
6-9	MH273295	Mech. Panel Prop, M-9	M9-302	4
6-10x	ZS414033	Screw, countersunk head 3x8		4
6-11	MS257051	Lever FA Shaft	900-127	1
6-12x	ZW413267	Flange Nut M4		1
6-13	HZ247511	Head Prop C	900-142	3
6-14x	ZS413201	Screw, pan head 4x8		2
6-15x	ZS414044	Screw, countersunk head 4x8		1
6-16x	MH410938	Belt Guide Pin	LF-1009	1
6-17x	MH248343	Belt Guide Pin (CSA)	4TR-109	1
6-18	ZW413188	Nut M4		7
6-19	MZ257073	Lever FB Guide Base	M9-103	1
6-20x	ZS417150	Screw, pan head 4x6		2
6-21	ZG257095	Lever FB Vibration Proof Spring	M8-104	1
6-22	MS245463	Brake Lever Shaft	900-129	2
6-23x	MS245463	Brake Lever Shaft (CSA)	900-129	1
6-24	MZ312524	Shifter Cam	LD-106	1
6-25	MZ312535	Shifter Cam Collar	LD-107	1
6-26	ZS393726	Screw, truss head 3x10		1
6-27	ES250007	Micro SW. M-8-3 U/L	25-1-6	1
6-28	MZ585887	Actuator B, w/pin lever	LS-1202	1
6-29x	ZS349288	ISO Screw, binding head 3x5, w/washer		2
6-30	ZS323728	Screw, binding head 3x5		8
6-31	ZS422965	Screw, pan head 3x15		2
6-32	MZ606993	Stopper Angle	LE-1305	1
6-33x	ZS422076	Screw, pan head 3x5		1
6-34x	ER376424	Spark Quencher U/L 0.1μ+120Ω 500WV	41-1-36	1
6-35x	ZW273914	Spring Washer M4		2
6-36x	ZW462835	Washer (PBP) D4.3x11x0.2t		1
6-37x	ZW462846	Washer (PBP) D4.3x11x0.3t		1
6-38x	ZW462857	Washer D4.3x11x0.4t		1
6-39x	ZW462868	Washer D4.3x11x0.5t		1
6-40	ML475920	New Spring Hook	900-185	1
6-41	MS260515	A Lever Shaft	900-126	1
6-42x	ZW273960	Nut M4		1
6-43	ML309093	Lever B, w/lever D	900-103	1
6-44	MR217203	Cam Roller A (Nylon) D12	900-153	2
6-45	ZW290283	'U' Ring 2.85M	6-1-1	15
6-46	ZG469427	Spring B-1	LS-2004	1
6-47	MZ253653	Metal Mt. Parts, w/metal	900-174	1
6-48x	ZS413201	Screw, pan head 4x8		1
6-49x	ZW413267	Flange Nut M4		1
6-50	ML270685	G Lever, w/lever HB	900-109	1
6-51x	ZS413234	Screw, pan head 4x12		3
6-52	MZ217708	Pause Lever Retaining Parts B	900-170	1
6-53x	ZW260054	Washer (SUP) D6.1x10x0.25t		1
6-54x	ZG227485	Spring E	900-119	1
6-55	ZG227575	Spring I	900-121	2
6-56x	MZ256814	Rewind Shaft Spacer	M9-124	2
6-57	ZG208091	Impedance Arm Spring	RD-269	1
6-58	MZ312748	Shifter Spoke	LD-108	1
6-59	MZ293567	Head Lifter Cam A #1630	1630-104	1
6-60	MZ293578	Head Lifter Cam B #1630	1630-105	1
6-61x	ZS349288	ISO Screw, binding head 3x5, w/washer		1

Ref. No.	Parts No.	Description	Schematic No.	Q'ty
6-62	ML217934	Supply Brake, w/pin	900-113	1
6-63	MT245215	Brake Rubber (Large)	900-163	2
6-64x	ZS245801	Brake Roller Retaining Screw	900-134	2
6-65x	ZW259942	Washer (Fiber) D5.1x10.3x0.5t		3
6-66x	ZW260133	Washer (Fiber) D6.1x10x1t		3
6-67	ML251932	Take-up Brake, w/pin	900-114	1
6-68	ZW290283	'U' Ring 2.85M	6-1-1	2
6-69	ML607004	Lever A (New), w/pin	LE-1004	1
6-70	ML548280	Lever LF	LF-1013	1
6-71x	ZS201767	Screw, pan head 4x6, w/washer		2
6-72x	ZW259918	Washer (SUP) D5.1x10.3x0.25t		4
6-73	ZG290384	UN Spring D	1630-108	1
6-74	ML256983	Lever C2	900-104	1
6-75	ZG227452	Spring D	900-118	1
6-76	ZG227441	Spring C	900-117	1
6-77	MZ260662	AS Lever Prop Base, w/prop	4TR-236	1
6-78	ZW273767	Earth Lug D3x20L		1
6-79	ML257040	Lever FA, w/shaft B	900-107	1
6-80	MR217203	Cam Roller A (Nylon) D12	900-153	1
6-81	ML295727	2-Speed Motor Lever F, w/shaft	M8-107	1
6-82x	ZW260087	Washer (Fiber) D6.1x10x0.5t		2
6-83	ZG270358	F.B. Pull Spring	M8-108	1
6-84	ML257163	Lever K, w/shaft	900-111	1
6-85	ZW432347	Washer (Luminar) D6.2x13x0.125t		2
6-86	ZS223233	Fulcrum Screw A	900-135	1
6-87	ML243540	Pinch Roller Lever	900-161	1
6-88	MS243404	Pinch Roller Shaft C	4TR-102	1
6-89x	ZW259975	Washer (SUP) D5.1x10.3x0.8t		1
6-90	MR269763	Cam Roller D13	900-154	1
6-91	MS582906	Cam Roller Shaft A-1	7-3-6	1
6-92	ZG227417	Spring A	900-115	1
6-93x	ZW376391	Washer (polyslider) D6.1x10x0.13t		1
6-94	ML479957	Pause Lever, LE	LE-1001	1
6-95	ZS217877	Pause Lever Set Screw	900-136	1
6-96	MZ217855	Pause Stopper	900-169	1
6-97	ZG217866	Pause Lever Spring A	900-123	1
6-98	MZ610457	Pause Lever Cushion	LE-1005	1
6-99	MZ217113	Cam Stopper B	RC-129	1
6-100	ZW217102	Cam Stopper Insulator Washer	900-165	1
6-101	ZS413245	Screw, pan head 4x15		2
6-102	SB258478	Rec. Button (Red)	900-167	1
6-103	MC479968	Counter MP-491-28	9-1-23	1
6-104x	MB406168	Counter Belt D123x1.8	3-3-14	1
6-105	BL204658	AS Lever Block Comp. #2		1
6-106x	ZW322525	Washer (PBP) D4.1x7x0.2t		1
6-107	ZW290294	'U' Ring 2.85M	6-1-1B	1
6-108	ML204423	Idler Wheel Comp. #2		2
6-109x	ZW260076	Washer (Nylon) D6.1x10x0.5t		3
6-110x	ZW376391	Washer (Polyslider) D6.1x10x0.13t		3
6-111	MI231423	Middle Wheel, w/metal	900-155	1
6-112	ZW260144	Washer (Nylon) D6.1x10x0.3t		1
6-113x	MP204794	Pinch Roller #3 D=40	3A-348	1
6-114x	EJ317125	TV-Consent-Plug 5P	42-1-6	1
6-115x	MZ396393	Lock Wire Tie 11M/M		1
6-116x	RJ205986	Cramp Terminal 2-SD	32-1-8	2
6-117	ML226258	Start Lever A, w/lever B-2	4TR-122	1
6-118	SB485741	Start Button C	MS-1002	1
6-119x	ZS425788	Screw, round head 3x4		2
6-120x	MZ452496	Cycle Angle (CEE)	LS-1007	1
6-121x	MH245485	Brake Lever Pin (CSA)	MH-138	1
6-122x	ML308564	Belt Vibration Stopper (CSA)	MH-137	1
6-123x	EJ299823	Mate-N-Lock Cap Housing 6P 1-480276-0	52-1-2	1
6-124x	EJ243191	Pin Contact 60511-1	52-1-1	4
6-125	ZG217394	Belt Change Spring B	MH-125	1
6-126	MZ316956	Cam A-3	MR-242	1
6-127	ZS413201	Screw, pan head 4x8		1
6-128	MZ217293	Cam B-2 (without Tap)	1630-201	1
6-129	MV270066	Steel Ball D8		1

When ordering parts, please describe Parts Number, Serial Number, and Model Number in detail.

**FIG. 7 PHOTO OF PRE-AMP. P.C. BOARD
 (LE-5306) BLOCK**

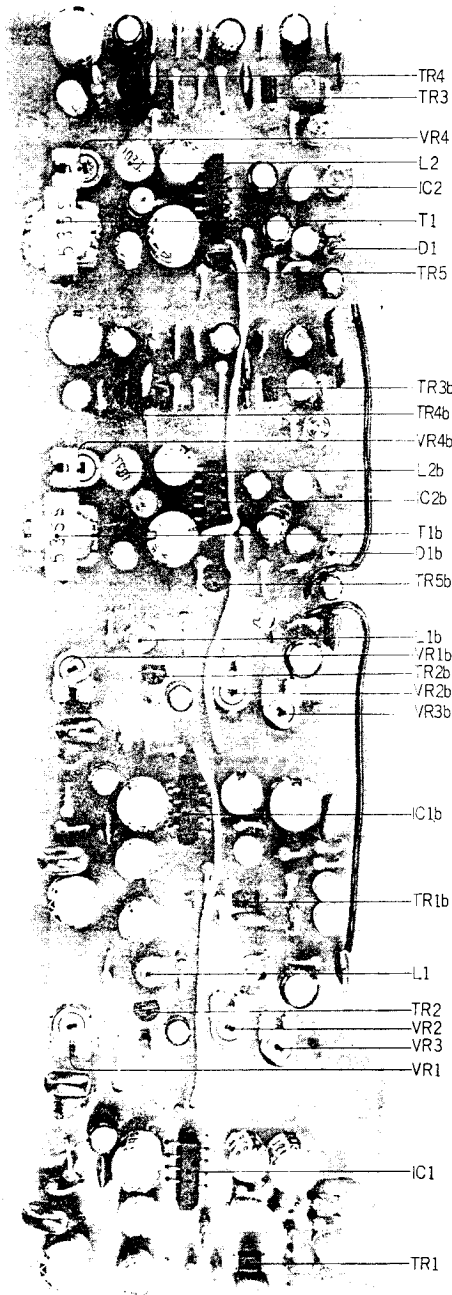

PRE-AMP. P.C. BOARD (LE-5306) BLOCK

Symbol No.	Parts No.	Description	Q'ty
7-1x	BA588947	Pre-Amp. P.C. Board Comp. (LE-5306)	1
7-TR1	ET234854	Transistor 2SC458LG(C)	2
7-TR2	ET453486	Transistor 2SC711(E) (F)	2
7-TR3	ET234854	Transistor 2SC458LG(C)	2
7-TR4	ET550754	Transistor 2SC1312(G)	2
7-TR5	ET453486	Transistor 2SC711(E) (F)	2
7-IC1, 2	EI412413	I.C. Line Amp. LD-3141	4
7-D1	ED219464	Germanium Diode 1N34A	2
7-L1	EO424866	Ferri Inductor FL7H 1.2MH(J)	2
7-L2	EO244001	Ferri Inductor FL9H 10MH(J)	2
7-T1	BT517274	Headphone Trans. N16-535S	2
7-VR1	EV464196	Semi-Fixed/Vol. V8K4-1 2 kB	2

Symbol No.	Parts No.	Description	Q'ty
7-VR2	EV520806	Semi-Fixed/Vol. V8K4-1 10 kB	2
7-VR3	EV464220	Semi-Fixed/Vol. V8K4-1 50 kB	2
7-VR4	EV522797	Semi-Fixed/Vol. V8K4-1 20 kB	2
Capacitor, Vertical Type			
7-C1	EC432810	Elect. 10µF 16WV NL	2
7-C2	EC336104	Elect. 100µF 6.3WV	2
7-C3	EC493323	Elect. 1µF 25WV NL	2
7-C4, 5	EC336126	Elect. 47µF 25WV	4
7-C6	EC290520	VFM 100PF(J) 50WV	2
7-C7	EC432810	Elect. 10µF 16WV NL	2
7-C8, 9	EC336104	Elect. 100µF 6.3WV	4
7-C10	EC368335	Mylar 0.022µF(J) 50WV	2
7-C11	EC446297	Mylar 0.18µF(J) 50WV	2
7-C12	EC220994	Elect. 10µF 25WV	2
7-C13	EC446297	Mylar 0.18µF(J) 50WV	2
7-C14	EC336126	Elect. 47µF 25WV	2
7-C15	EC320051	Elect. 10µF 16WV	2
7-C16	EC379157	Mylar 0.033µF(J) 50WV	2
7-C17	EC405898	Styrol 470PF(J) 50WV	2
7-C18	EC350684	Elect. 22µF 25WV	2
7-C19	EC451462	VFM 150PF(J) 50WV	2
7-C20	EC336126	Elect. 47µF 25WV	2
7-C21	EC480071	Elect. 22µF 16WV NL	2
7-C22	EC513990	Styrol 330PF(J) 50WV	2
7-C23	EC329771	Elect. 47µF 6.3WV	2
7-C24	EC290520	VFM 100PF(J) 50WV	2
7-C25	EC514708	Elect. 4.7µF 25WV NL	2
7-C26	EC329771	Elect. 47µF 6.3WV	2
7-C27	EC389485	Mylar 0.018µF(J) 50WV	2
7-C28	EC562678	Styrol 750PF(J) 50WV	2
7-C29	EC389474	Mylar 0.0015µF(J) 50WV	2
7-C30	EC336126	Elect. 47µF 25WV	2
7-C31	EC513955	Styrol 220PF(J) 50WV	2
7-C32	EC493323	Elect. 1µF 25WV NL	2
7-C33	EC329771	Elect. 47µF 6.3WV	2
7-C34	EC336104	Elect. 100µF 6.3WV	2
7-C35	EC513955	Styrol 220PF(J) 50WV	2
7-C36	EC220994	Elect. 10µF 25WV	2
7-C37 to 39	EC320051	Elect. 10µF 16WV	6
7-C40	EC290520	VFM 100PF(J) 50WV	2
Resistor, Stopper Type			
7-R1	ER480060	Carbon RD1/4 33k(J) NL	2
7-R2	ER380711	Carbon RD1/4 220k(J)	2
7-R3	ER306360	Carbon RD1/4 6.8k(J)	2
7-R4	ER349907	Carbon RD1/4 33k(J)	2
7-R5	ER211465	Carbon RD1/4 1k(J)	2
7-R6	ER213030	Carbon RD1/4 5.6k(J)	2
7-R7, 8	ER346601	Carbon RD1/4 47k(J)	4
7-R9	ER212883	Carbon RD1/4 4.7k(J)	2
7-R10	ER380711	Carbon RD1/4 220k(J)	2
7-R11	ER346994	Carbon RD1/4 18k(J)	2
7-R12	ER336442	Carbon RD1/4 10k(J)	2
7-R13	ER306887	Carbon RD1/4 15k(J)	2
7-R14	ER336442	Carbon RD1/4 10k(J)	2
7-R15	ER342933	Carbon RD1/4 27k(J)	2
7-R16	ER213300	Carbon RD1/4 680(J)	2
7-R17	ER306843	Carbon RD1/4 1.2k(J)	2
7-R18	ER211667	Carbon RD1/4 100(J)	2
7-R19	ER588148	Carbon RD1/4 36(J)	2
7-R20	ER357570	Carbon RD1/4 150k(J)	2
7-R21	ER336442	Carbon RD1/4 10k(J)	2
7-R22	ER362485	Carbon RD1/4 330k(J)	2
7-R23	ER212681	Carbon RD1/4 330(J)	2
7-R24	ER212883	Carbon RD1/4 4.7k(J)	2
7-R25	ER212477	Carbon RD1/4 3.3k(J)	2
7-R26, 27	ER212264	Carbon RD1/4 22k(J)	4
7-R28	ER450011	Carbon RD1/4 120k(J)	2
7-R29	ER324202	Carbon RD1/4 5.1k(J)	2
7-R30	ER380755	Carbon RD1/4 6.2k(J)	2
7-R31	ER212883	Carbon RD1/4 4.7k(J)	2
7-R32	ER211465	Carbon RD1/4 1k(J)	2
7-R33	ER211757	Carbon RD1/4 100k(J)	2
7-R34	ER420322	Carbon RD1/4 36k(J)	2
7-R35	ER212883	Carbon RD1/4 4.7k(J)	2
7-R36	ER306843	Carbon RD1/4 1.2k(J)	2

When ordering parts, please describe Parts Number, Serial Number, and Model Number in detail.

FIG. 8 PHOTO OF OSC. POWER SUPPLY P.C. BOARD (LE-5021) BLOCK

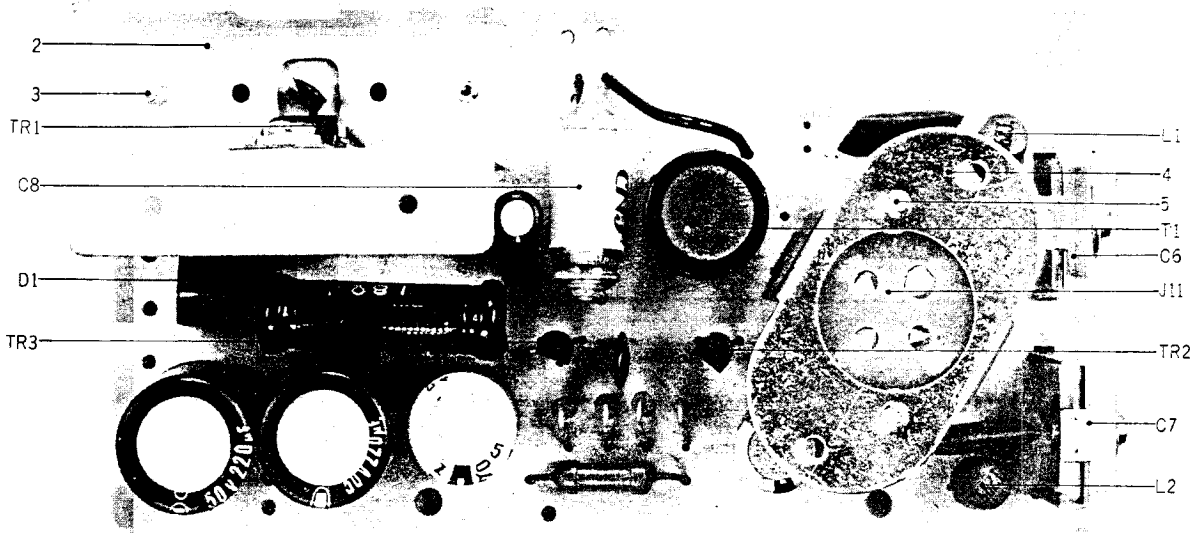

OSC. POWER SUPPLY P.C. BOARD
(LE-5021) BLOCK

Symbol No.	Parts No.	Description	Q'ty
8-1x	BA480306	Osc. Power Supply P.C. Board Comp. (LE-5021)	1
8-TR1	ET476886	Transistor 2SC1098(L) (M)	1
8-TR2	ET511920	Transistor 2SC1247A(B) (V)	2
8-D1	ED329130	Silicon Diode 10DC-1 (Black)	1
8-D2	ED511918	Zener Diode WZ-240	1
8-T1	EO383365	Osc. Coil OT-204	1
8-L1, 2	EO321254	Ferri Inductor FL7H 5.6MH(J)	2
8-J11	EJ374027	Socket 4P (T Type)	1
8-2	EZ480396	Heat-sink Plate	1
8-3	ZS379405	ISO Screw, binding head 3x6	3
8-4	EZ480418	Socket Table	1
8-5	ZS325495	Tapping Screw #2 3x6	2
Capacitor, Vertical Type			
8-C1, 2	EC337533	Elect. 220 μ F 50WV	2
8-C3	EC336115	Elect. 220 μ F 25WV	1
8-C4, 5	EC350717	VFM 390PF(J) 50WV	2
8-C6, 7	EC425250	Trimmer A-1P3-3 70PF	2
8-C8	EC520492	Styrol 5600PF(J) 500WV (Tub. Type)	1
8-C9	EC336126	Elect. 47 μ F 25WV	1
8-C10, 11	EC250841	Mylar 0.01 μ F(J) 50WV	2
8-C12	EC350875	Mylar 0.001 μ F(J) 50WV	1
8-C13	EC220994	Elect. 10 μ F 25WV	1
Resistor, Stopper Type			
8-R1	ER212883	Carbon RD1/4 4.7k(J)	1
8-R2	ER361642	Carbon RD1/4 47(J)	1
8-R3	ER413717	Wire-wound 3W 18(J) (L Type)	1
8-R4	ER398856	Metal Oxide Film 1W 100(K)	1
8-R5	ER212883	Carbon RD1/4 4.7k(J)	1
8-R6	ER304402	Carbon RD1/4 470(J)	1
8-R7, 8	ER315944	Carbon RD1/4 3.3(J)	2

FIG. 9 PHOTO OF DOLBY P.C. BOARD (LE-5307) BLOCK

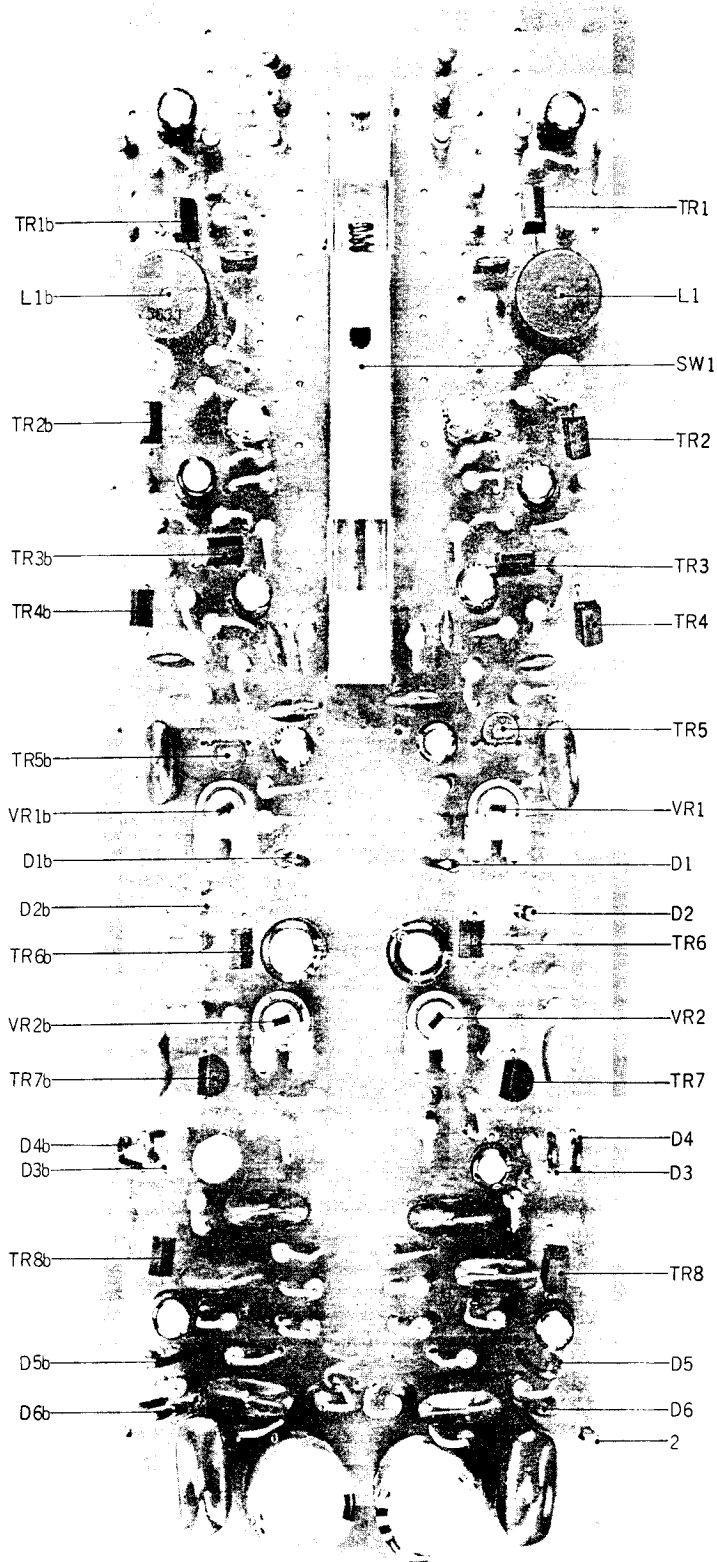

For Service Manuals Contact
MAURITRON TECHNICAL SERVICES
 8 Cherry Tree Rd, Chinnor
 Oxon OX9 4QY
 Tel: 01844-351694 Fax: 01844-352554
 Email: enquiries@mauriton.co.uk

DOLBY P.C. BOARD (LE-5307) BLOCK

Symbol No.	Parts No.	Description	Q'ty	Symbol No.	Parts No.	Description	Q'ty
9-1x	BA589127	Dolby P.C. Board Comp. (LE-5307)	1	9-R38	ER361642	Carbon RD1/4 47(J)	2
9-TR1	ET391768	Transistor 2SC458LG(C) (D)	2	9-R39	ER211465	Carbon RD1/4 1k(J)	2
9-TR2	ET571781	Transistor 2SC458(C) (D)	2	9-R40	ER380913	Carbon RD1/4 33(J)	2
9-TR3	ET391768	Transistor 2SC458LG(C) (D)	2	9-R41	ER306887	Carbon RD1/4 15k(J)	2
9-TR4	ET571781	Transistor 2SC458(C) (D)	2	9-R42, 43	ER426857	Carbon RD1/4 270k(J)	4
9-TR5	ET491051	FET 2SK30A (GR)	2	9-R44	ER450011	Carbon RD1/4 120k(J)	2
9-TR6	ET391768	Transistor 2SC458LG(C) (D)	2	9-R45	ER211757	Carbon RD1/4 100k(J)	2
9-TR7	ET538110	Transistor 2SA628(D) (E)	2				
9-TR8	ET571781	Transistor 2SC458(C) (D)	2				
9-D1	ED219464	Germanium Diode 1N34A	2				
9-D2	ED491130	Zener Diode WZ-085	2				
9-D3, 4	ED514721	Silicon Diode WG-599	4				
9-D5	ED219464	Germanium Diode 1N34A	2				
9-D6	ED514721	Silicon Diode WG-599	2				
9-SW1	ES588284	Slide SW. CL-210E	1				
9-L1	EO496350	Inductor 146LY 36MH(J)	2				
9-VR1	EV464207	Semi-Fixed/Vol. V8K4-1 5 kB	2				
9-VR2	EV523620	Semi-Fixed/Vol. V8K4-1 500B	2				
9-2	EJ350447	Test Terminal	2				
		Capacitor, Vertical Type					
9-C1	EC320051	Elect. 10 μ F 16WV	2				
9-C2	EC350875	Mylar 0.001 μ F(J) 50WV	2				
9-C3	EC513988	Styrol 270PF(J) 50WV	2				
9-C4 to 6	EC320051	Elect. 10 μ F 16WV	6				
9-C7	EC329883	Mylar 0.0056 μ F(J) 50WV	2				
9-C8	EC337500	Mylar 0.0047 μ F(J) 50WV	2				
9-C9	EC329861	Mylar 0.027 μ F(J) 50WV	2				
9-C10	EC320051	Elect. 10 μ F 16WV	2				
9-C11	EC251291	Mylar 0.1 μ F(K) 50WV	2				
9-C12	EC320040	Elect. 47 μ F 16WV	2				
9-C13	EC290520	VFM 100PF(J) 50WV	2				
9-C14	EC320051	Elect. 10 μ F 16WV	2				
9-C15, 16	EC251291	Mylar 0.1 μ F(K) 50WV	4				
9-C17	EC320051	Elect. 10 μ F 16WV	2				
9-C18	EC251291	Mylar 0.1 μ F(K) 50WV	2				
9-C19	EC395504	Mylar 0.33 μ F(K) 50WV	2				
9-C20	EC336115	Elect. 220 μ F 25WV	2				
		Resistor, Stopper Type					
9-R1	ER336442	Carbon RD1/4 10k(J)	2				
9-R2	ER324202	Carbon RD1/4 5.1k(J)	2				
9-R3	ER336442	Carbon RD1/4 10k(J)	2				
9-R4	ER211667	Carbon RD1/4 100(J)	2				
9-R5	ER306887	Carbon RD1/4 15k(J)	2				
9-R6	ER429996	Carbon RD1/4 470k(J)	2				
9-R7	ER346601	Carbon RD1/4 47k(J)	2				
9-R8	ER212477	Carbon RD1/4 3.3k(J)	2				
9-R9	ER304402	Carbon RD1/4 470(J)	2				
9-R10	ER212264	Carbon RD1/4 22k(J)	2				
9-R11	ER336442	Carbon RD1/4 10k(J)	2				
9-R12	ER343078	Carbon RD1/4 2.7k(J)	2				
9-R13	ER349907	Carbon RD1/4 33k(J)	2				
9-R14	ER357570	Carbon RD1/4 150k(J)	2				
9-R15	ER212174	Carbon RD1/4 180k(J)	2				
9-R16	ER212264	Carbon RD1/4 22k(J)	2				
9-R17	ER357570	Carbon RD1/4 150k(J)	2				
9-R18	ER212264	Carbon RD1/4 22k(J)	2				
9-R19	ER349942	Carbon RD1/4 8.2k(J)	2				
9-R20	ER343078	Carbon RD1/4 2.7k(J)	2				
9-R21, 22	ER349907	Carbon RD1/4 33k(J)	4				
9-R23	ER357535	Carbon RD1/4 39k(J)	2				
9-R24	ER212477	Carbon RD1/4 3.3k(J)	2				
9-R25	ER349942	Carbon RD1/4 8.2k(J)	2				
9-R26	ER306843	Carbon RD1/4 1.2k(J)	2				
9-R27	ER430097	Carbon RD1/4 680k(J)	2				
9-R28	ER357456	Carbon RD1/4 2.2k(J)	2				
9-R29	ER306887	Carbon RD1/4 15k(J)	2				
9-R30	ER349942	Carbon RD1/4 8.2k(J)	2				
9-R31	ER336442	Carbon RD1/4 10k(J)	2				
9-R32, 33	ER349942	Carbon RD1/4 8.2k(J)	4				
9-R34	ER349907	Carbon RD1/4 33k(J)	2				
9-R35	ER450011	Carbon RD1/4 120k(J)	2				
9-R36	ER346601	Carbon RD1/4 47k(J)	2				
9-R37	ER343078	Carbon RD1/4 2.7k(J)	2				

When ordering parts, please describe Parts Number, Serial Number, and Model Number in detail.

FIG. 10 PHOTO OF AMP. ASSEMBLY BLOCK

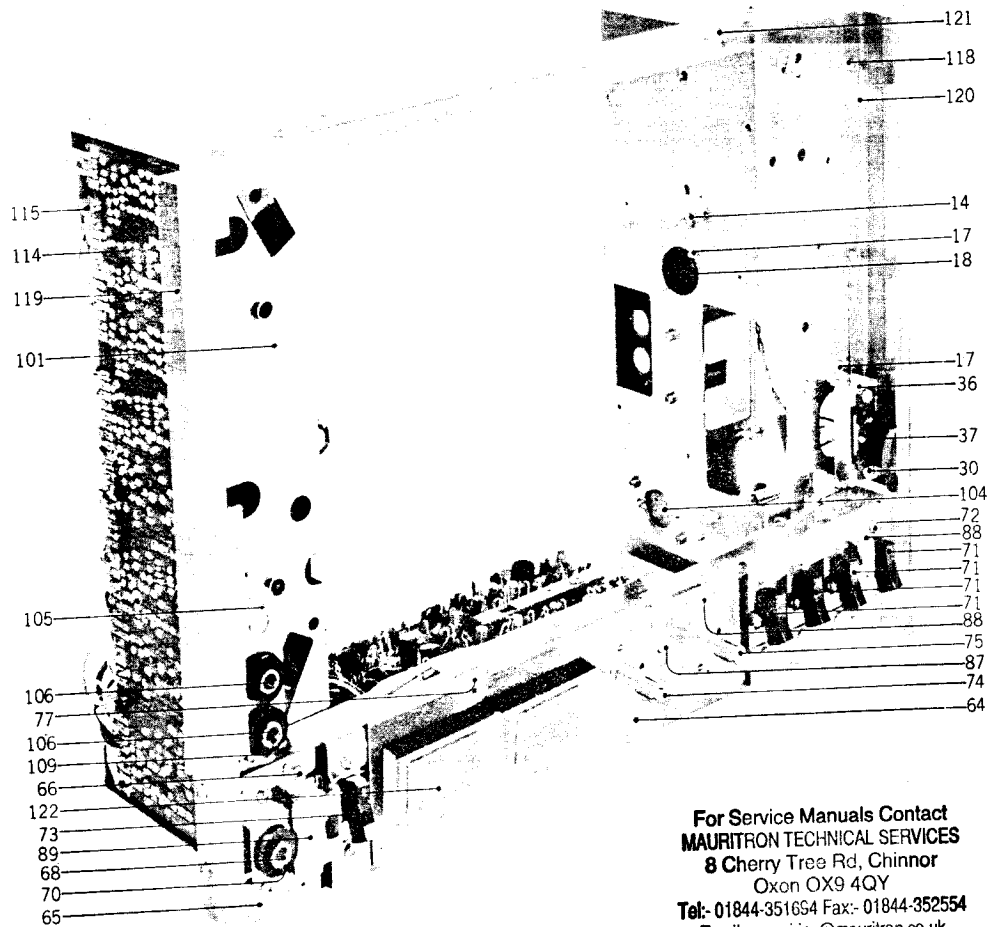

For Service Manuals Contact
MAURITRON TECHNICAL SERVICES
 8 Cherry Tree Rd, Chinnor
 Oxon OX9 4QY
 Tel: 01844-351654 Fax: 01844-352554
 Email: enquiries@mauritron.co.uk

AMP. ASSEMBLY BLOCK

Ref. No.	Parts No.	Description	Schematic No.	Q'ty	Ref. No.	Parts No.	Description	Schematic No.	Q'ty
	POWER SUPPLY FRAME BLOCK								
10-1x	BZ588971	Power Supply Frame Block Comp.	LE-3	1	10-20	EZ480824	Rec. SW. Holder	LE-5013	1
10-2x	BZ588982	Power Supply Frame Block Comp. (CSA)	LE-3	1	10-21	ES317744	Slide SW. SL-242B4V	25-3-28	1
10-3x	BZ588993	Power Supply Frame Block Comp. (CEE)	LE-3	1	10-22x	ZS461935	Screw, round head 2.6x4		2
10-4x	BZ589004	Power Supply Frame Block Comp. (JPN)	LE-3	1	10-23	ZG227428	Spring B	900-116	1
10-5x	BZ589015	Power Supply Frame Block Comp. (3 core)	LE-3	1	10-24x	ZW273756	Nut M3		2
10-6	EZ583468	Power Supply Frame D	LE-5009	1	10-25	ML493277	Rec. SW. Return Lever	LE-5036	1
10-7x	EZ494853	Power Supply Frame C (CSA, CEE)	LE-5009	1	10-26	ZS207314	Amp. Lever Set Screw	3A-737	2
10-8	BT480014	Power Trans. LET-1	38-4-162	1	10-27x	ZS325495	Tapping Screw #2 3x6		8
10-9x	BT480036	Power Trans. LET-3 (CSA)	38-4-160	1	10-28	ES479485	Slide SW. S-1	25-3-66	1
10-10x	BT480047	Power Trans. LET-4 (CEE)	38-4-161	1	10-29	SM223817	Name Plate, Frequency		1
10-11x	BT588407	Power Trans. LET-14 (JPN)	38-4-281	1			Change	3A-741	1
10-12x	ZS434250	Screw, pan head 4x8, w/washer		2	10-30	ZS323728	Screw, binding head 3x5		6
10-13x	ZW273914	Spring Washer M4		2	10-31x	EJ299834	Mate-N-Lock Plug Housing 6P 1-480273-0 (CSA)	52-1-2	1
10-14	ZW416698	Nut M4		2	10-32x	EJ229353	Socket Contact 60510-1 (CSA)	52-1-1	2
10-15	EZ481296	Trans. Shield, LE	LE-5034	1	10-33x	EZ583817	Mate-N-Lock Table (CSA)	LE-5314	1
10-16x	EZ235113	Trans. Cover Moltplane	LD-535	1	10-34x	ZW273881	Earth Lug M4		1
10-17	ZS325495	Tapping Screw #2 3x6		3	10-35x	ZW273802	Toothed Lock Washer M3		1
10-18	EJ277108	TV-Consent-Socket 5P	31-1-19	2	10-36	EZ480846	Power SW. Table	LE-5011	1
10-19	ER376413	Spark Quencher U/L 0.033μ+120Ω 500WV	41-1-37	3	10-37	ES480857	Seesaw SW. TV-3, JA-07, w/loose hole	25-2-29	1
					10-38x	ES480868	Seesaw SW. JS-07 (JA-04 250V 5A) (CEE)	25-2-31	1
					10-39x	EJ254970	Lug Plate KP1L1 (CSA)	33-3-3	1
					10-40	EJ233370	Socket (Volt. Selector) S-18010	40-2-3	1
					10-41	ZS379405	ISO Screw, binding head 3x6		2

When ordering parts, please describe Parts Number, Serial Number, and Model Number in detail.

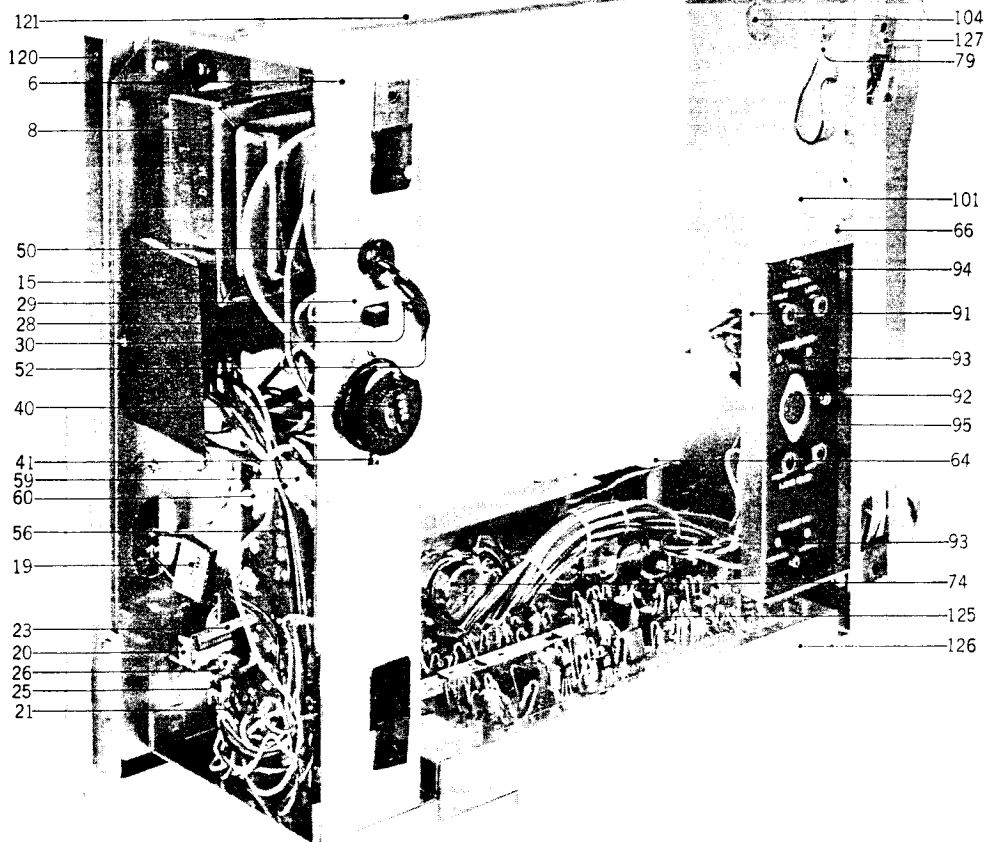

Ref. No.	Parts No.	Description	Schematic No.	Q'ty	Ref. No.	Parts No.	Description	Schematic No.	Q'ty
10-42x	EF575932	Fuse 0.8A 250V	39-1-50	1	10-67x	MZ599038	Reinforcement Angle	LE-5318	1
10-43x	EF277424	Fuse ST-4 0.8A (CSA)	39-1-28	1	10-68	EJ391083	Mic. Jack 3PMJ1P	31-2-28	1
10-44x	EF304626	Fuse ST-4 1A (CSA)	39-1-28	3	10-69x	ZW272722	Toothed Lock Washer M9		1
10-45x	EF238634	Fuse 400MAT (CEE) (T Type)		1	10-70	ZW270191	E Jack Nut		1
10-46x	EF375647	Fuse 500MAT (CEE) (T Type)		2	10-71	ES588262	Seesaw SW. 4C-2P	25-2-34	4
10-47x	EF563681	Fuse 1A 250V (JPN)	39-1-50	3	10-72	ZS323728	Screw, binding head 3x5		10
10-48x	EA583841	Fuse P.C. Board (CSA, JPN)	LE-5312	1	10-73	ES588273	Seesaw SW. 6C-2P	25-2-35	1
10-49x	EZ583852	Fuse Mt. Angle (CSA, JPN)	LE-5313	1	10-74	EV480565	Double/Vol. DJ10A		1
10-50	EZ382263	Strain Relief SR-4K-4	2-7-12	1	10-75	EV603134	Double/Vol. V24L5DS	36-3-41	1
10-51x	EZ246936	Strain Relief SR-6W-1 (WG, 3 core)	2-7-8	1	10-76x	EZ584021	Lamp Table	36-12-7	1
10-52	EW540112	AC Cord 2.5M (CUL)	26-3-19	1	10-77	EJ603145	Lamp Terminal Plate B	LE-5317	1
10-53x	EW516600	Power Cord VM-0065(CEE)	26-3-28	1	10-78x	ER591186	Lamp 6.3V 150MA	33-2-37	2
10-54x	EW524845	AC Cord 2.5M (JPN)	26-3-31	1	10-79	ZW562476	Earth Lug M3	28-2-35	2
10-55x	EW315448	Australia Cord (3 core)	26-3-11	1	10-80x	ZW273802	Toothed Lock Washer M3		4
10-56	BA480306	Osc. Power Supply P.C. Board Comp. LE	LE-5021	1	10-81x	ER345712	Carbon/R. RD1/4 22k(J) (Insu. Type)	35-9-5	1
10-57x	ZS349288	ISO Screw, binding head 3x5, w/washer	3A-745	4	10-82x	ER364948	Carbon/R. RD1/4 3.3k(J) (Insu. Type)	35-9-5	2
10-58x	MZ259233	Wire Band C	32-1-7	2	10-83x	EC329883	Mylar/C. 0.0056μF(J) 50WV (Vert. Type)	24-1-1	2
10-59	EJ205975	Cramp Terminal 1-SD	2-35-1	4	10-84x	EC379157	Mylar/C. 0.033μF(J) 50WV (Vert. Type)	24-1-1	2
10-60	MZ229138	Wire Bundle Holder N-108	32-1-8	1	10-85x	EC250841	Mylar/C. 0.01μF(J) 50WV (Vert. Type)	24-1-1	2
10-61x	EJ205986	Cramp Terminal 2-SD (JPN)	LE-5042	4	10-86x	EA579082	Rec. P.C. Board	LF-5314	1
10-62x	EZ527095	Insulator Cloth		1	10-87	EL338196	Lamp (No. 2) 8V 0.2A	28-2-9	1
		CONTROL CHASSIS BLOCK			10-88	EZ582423	Panel Support A	LE-5302	2
10-63x	BZ589094	Control Chassis Block Comp.	LE-3	1	10-89	EZ582434	Panel Support B	LE-5303	1
10-64	EZ582636	Control Frame	LE-5301	1					
10-65	EZ489363	Phone Jack Base	LE-5205	1					
10-66	ZS325495	Tapping Screw #2 3x6		15					

When ordering parts, please describe Parts Number, Serial Number, and Model Number in detail.

Ref. No.	Parts No.	Description	Schematic No.	Q'ty
JACK PLATE BLOCK				
10-90x	BJ588925	Jack Plate Block Comp.	LE-3	1
10-91	EZ489677	Jack Plate Holder	LE-5208	1
10-92	EJ602188	Jack Plate C, w/jack	31-5-114	1
10-93	ES484154	Slide SW. U/L 6P (Small)		
		SJ-0282	25-3-36	1
10-94	ZS447840	Tapping Screw #2 3x8 (BR)		4
10-95	SM578250	Jack Name Plate C	LE-6222	1
10-96x	ER450101	Carbon/R. RD1/4 330k(J)		
		(Insu. Type)	35-9-5	2
10-97x	ER345712	Carbon/R. RD1/4 22k(J)		
		(Insu. Type)	35-9-5	4
10-98x	ER214290	Carbon/R. RD1/4 4.7k(J)		
		(Insu. Type)	35-9-5	2
10-99x	ER315213	Carbon/R. RD1/4 8.2k(J)		
		(Insu. Type)	35-9-5	2
AMP. CHASSIS BLOCK				
10-100x	BZ538892	Amp. Chassis Block Comp.	LE-3	1
10-101	EZ430598	Amp. Chassis	LE-5001	1
10-102x	EZ430600	P.C. Board Angle	LE-5006	1
10-103x	ZS325495	Tapping Screw #2 3x6		11
10-104	EJ298607	Jack, 4P	31-1-10	1
10-105	EZ488957	Mic. Jack Table	LE-5206	1
10-106	EJ448075	Mic. Jack 2PMJ1	31-2-23	2
10-107x	EZ225180	Nylon Collar, Jack	LD-520	2
10-108x	ZW455275	Washer (Fiber)		
		D9.1x18x0.5t		2
10-109	ZW554624	E Jack Nut	7-1-56	2
10-110x	BJ588925	Jack Plate Block Comp.	LE-3	1
10-111x	MZ259233	Wire Band C	3A-745	1
10-112x	ZW273881	Earth Lug M4		1
10-113x	ZW273802	Toothed Lock Washer M3		1
AMP. ASSEMBLY BLOCK				
10-114	BA588947	Pre-Amp. P.C. Board Block		
		Comp.	LE-5306	1
10-115	MH314504	Shield Plate Prop	MR-525	2
10-116x	EZ480756	Shield Plate	LE-5008	1
10-117x	ZW273756	Nut M3		2
10-118	ZS325495	Tapping Screw #2 3x6		17
10-119	SZ480982	Sash Angle A (Left)	LE-6008	1
10-120	SZ480993	Sash Angle B (Right)	LE-6008	1
10-121	EZ225303	Upper Angle	LD-508	1
10-122	EM480778	VU Meter B-1914R	46-1-57	2
10-123x	EZ480780	Lamp Mask	LE-5023	1
10-124x	EZ486865	Lamp Mask B	LE-5035	2
10-125	BA589127	Dolby P.C. Board Block		
		Comp.	LE-5307	1
10-126	EZ582546	Dolby P.C. Board Table	LE-5305	1
10-127	ZW290248	U Type Speed Nut M4 #1		
		(Small)	6-3-1	1

For Service Manuals Contact
MAURITRON TECHNICAL SERVICES
 8 Cherry Tree Rd, Chinnor
 Oxon OX9 4QY
 Tel:- 01844-351654 Fax:- 01844-352554
 Email:- enquiries@mauritron.co.uk

FIG. 11 PHOTO OF FINAL ASSEMBLY BLOCK

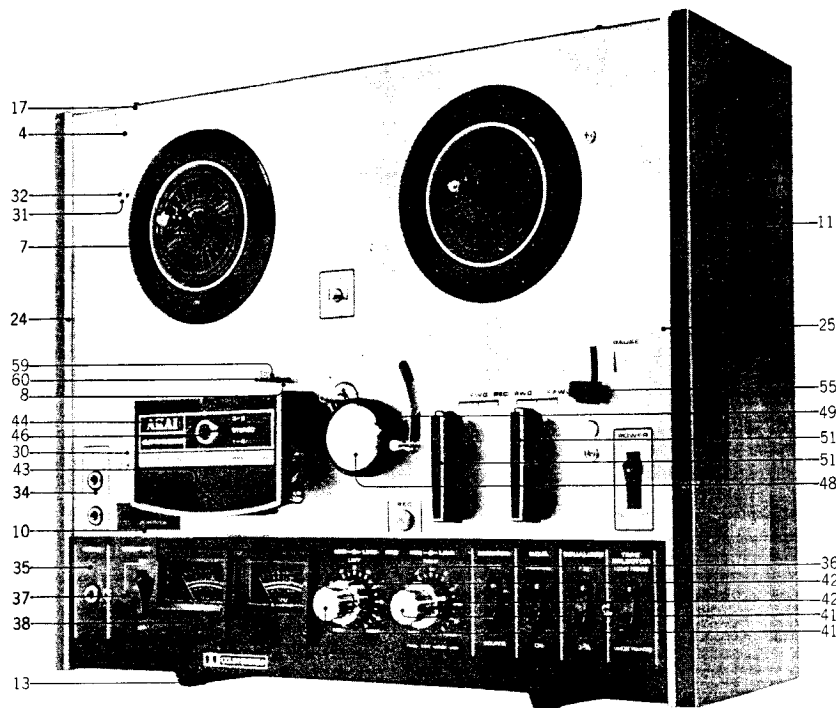

FINAL ASSEMBLY BLOCK

Ref. No.	Parts No.	Description	Schematic No.	Q'ty	Ref. No.	Parts No.	Description	Schematic No.	Q'ty
MECH. PANEL BLOCK									
11-1x	BZ588745	Mech. Panel Block Comp.	LE-3	1	11-28x	ZW419646	Washer (SPC) D4.5x9.8x0.5t		4
11-2x	BZ588756	Mech. Panel Block Comp.	LE-3	1	11-29x	ZS434283	Tapping Screw #1 4x30		4
		(CSA)	LE-3	1			(Truss)	LC-619	1
11-3x	BZ589432	Mech. Panel Block Comp.	(CEE) LE-3	1	11-30	SZ465388	Tape Guide Table B	KD-6029	4
11-4	SP578204	Mech. Panel A-1	LE-6001	1	11-31	ZW408418	Panel Washer		4
11-5x	SP578215	Mech. Panel B-1 (CSA)	LE-6001	1	11-32	ZS411660	Screw, oval countersunk head 3x6		4
11-6x	SP578226	Mech. Panel C-1 (CEE)	LE-6001	1	11-33x	ZS323728	Screw, binding head 3x5		1
11-7	SM489611	Reel Table Ring B	LE-6203	2	11-34	ZW526577	Collar B, Jack	MC-5006	3
11-8	SZ276816	Capstan Rest ST-1	100180	1	11-35	SP582614	Amp. Panel	LE-6301	1
11-9x	ZS327835	Screw, countersunk head 3x5		1	11-36	SE578125	Pilot Lamp Escutcheon (Red)	TN-6017	1
11-10	SE330895	Counter Escutcheon, MR	MR-646	1	11-37	SE583255	Pilot Lamp Escutcheon (Green)	TW-6017	1
CASE BLOCK									
11-11	BC588712	Case Block Comp.	LE-3	1	11-38	SE582480	Meter Escutcheon	LE-6406	2
11-12x	ZW413267	Flange Nut M4		4	11-39x	ZS483456	Screw, countersunk head 2.3x4		4
11-13	SZ609952	Tran Leg D	2-6-11	4	11-40x	ZS414336	Screw, truss head 3x6, w/washer (Black)		2
11-14x	ZW476155	Screw, pan head 4x18		4	11-41	SK576628	Knob A BL	LE-6012	2
11-15x	SE382217	Fan Grill	RD-A402	1	11-42	SK583266	Knob B-BL	LE-6015	2
11-16x	ZS324448	Tapping Screw #1 3x10 (Truss) (Black)		3	11-43	SC607015	Head Cover D	LE-6030	1
11-17	SZ480712	Dust Cover Pin	LE-6024	2	11-44	SM605845	Name Plate B, Head Cover	LE-6308	1
FINAL ASSEMBLY BLOCK									
11-18x	ZW290248	U Type Speed Nut M4 #1 (Small)	6-3-1	3	11-45x	ZW527670	Head Cover Retainer	ND-6018	2
11-19x	ZW290250	U Type Speed Nut M4 #1 (Large)	6-3-2	6	11-46	SK485651	Head Change Knob C	LE-6027	1
11-20x	ZS200610	Tapping Screw #1 4x12 (Truss)		4	11-47x	ZS434160	Set Screw, hexagon Socket 3x3 (cup/p.)		1
11-21x	ZW290283	'U' Ring 2.85M	6-1-1	1	11-48	SK583132	Pinch Roller Cap B	MS-6020	1
11-22x	SZ493042	Rec. Wire B	LE-6028	1	11-49	MP204794	Pinch Roller #3 D=40	3A-348	1
11-23x	ZS575976	Tapping Screw #1 4x30 Tru, w/washer		2	11-50x	ZW481072	Washer (SUP) D4x10x0.25t		1
11-24	SE582568	Sash (L)	LE-6302	1	11-51	SK476684	Mech. Knob	LE-6018	2
11-25	SE582557	Sash (R)	LE-6302	1	11-52x	ZS253405	Mech. Knob Screw	7-1-46	2
11-26x	ZS327835	ISO Screw, countersunk head 3x5		6	11-53x	ZW432347	Washer (Luminar) D6.2x13x0.125t		2
11-27x	SA377190	Rubber Foot, LM	LM-404	4	11-54x	ZW260201	Washer (Nylon) D6.2x13x1t		2
					11-55	SK314100	Pause Knob B	MR-612	1
					11-56x	ZS433001	Set Screw, hexagon Socket 3x5 (cup/p.)		1
					11-57x	SM578013	P.C. Board Plate	A0402	1
					11-58x	EF563670	Fuse 0.5A 250V	39-1-50	1
					11-59	MY270055	Capstan D=8	SRA-7	1
					11-60	ZS293027	Capstan Screw, 1100	SRA-6B	1

When ordering parts, please describe Parts Number, Serial Number, and Model Number in detail.

INDEX

Parts No.	Ref. No. & Symbol No.	Parts No.	Ref. No. & Symbol No.	Parts No.	Ref. No. & Symbol No.	Parts No.	Ref. No. & Symbol No.	Parts No.	Ref. No. & Symbol No.
BA480306	8-1x	EC379157	10-84x	ER212264	9-R18	ER480060	7-R1	HZ393974	1-13x
BA480306	10-56	EC389474	7-C29	ER212477	7-R25	ER588148	7-R19	HZ480420	1-9
BA588947	7-1x	EC389485	7-C27	ER212477	9-R8	ER591186	10-78x	HZ480431	1-15
BA588947	10-114	EC395504	9-C19	ER212477	9-R24	ES250007	6-27	HZ480442	1-17
BA589127	9-1x	EC405898	7-C17	ER212681	7-R23	ES257668	1-21	HZ480475	1-29
BA589127	10-125	EC410016	3-20	ER212883	7-R9	ES316934	5-9	HZ490296	1-2
BC588712	11-11	EC425250	8-C6	ER212883	7-R24	ES317744	10-21	MB256601	4-22
BF205075	4-1x	EC425250	8-C7	ER212883	7-R31	ES369865	5-10	MB406168	6-104x
BH480363	1-1x	EC432810	7-C1	ER212883	7-R35	ES479485	10-28	MC479968	6-103
BJ588925	10-90x	EC432810	7-C7	ER212883	8-R1	ES480857	10-37	MH204311	6-2
BJ588925	10-110x	EC446297	7-C11	ER212883	8-R5	ES480868	10-38x	MH244710	4-9
BL564107	4-14x	EC446297	7-C13	ER213030	7-R6	ES484154	10-93	MH245485	6-121x
BL204658	6-105	EC451462	7-C19	ER213300	7-R16	ES588262	10-71	MH248343	6-17x
BL588701	5-1x	EC480071	7-C21	ER214290	10-98x	ES588273	10-73	MH254160	3-11
BM601020	3-1x	EC493323	7-C3	ER304402	8-R6	ES588284	9-SW1	MH254182	3-12
BR589206	2-1x	EC493323	7-C32	ER304402	9-R9	ET234854	7-TR1	MH258581	5-32
BR589217	2-2	EC493525	3-21x	ER306360	7-R3	ET234854	7-TR3	MH270000	2-33
BS480352	5-7x	EC513955	7-C31	ER306843	7-R17	ET391768	9-TR1	MH273295	6-9
BT480014	10-8	EC513955	7-C35	ER306843	7-R36	ET391768	9-TR3	MH312827	1-8
BT480036	10-9x	EC513988	9-C3	ER306843	9-R26	ET391768	9-TR6	MH314504	10-115
BT480047	10-10x	EC513990	7-C22	ER306887	7-R13	ET453486	7-TR2	MH410938	6-16x
BT517274	7-T1	EC514708	7-C25	ER306887	9-R5	ET453486	7-TR5	MH605856	1-3x
BT588407	10-11x	EC520492	8-C8	ER306887	9-R29	ET476886	8-TR1	MI204423	6-108
BZ400948	6-1x	EC562678	7-C28	ER306887	9-R41	ET491051	9-TR5	MI231423	6-111
BZ588745	11-1x	ED219464	7-D1	ER315213	10-99x	ET511920	8-TR2	MI244473	4-2
BZ588756	11-2x	ED219464	9-D1	ER315944	8-R7	ET538110	9-TR7	ML217462	4-15
BZ588892	10-100x	ED219464	9-D5	ER315944	8-R8	ET550754	7-TR4	ML217934	6-62
BZ588971	10-1x	ED329130	8-D1	ER324202	7-R29	ET571781	9-TR2	ML226258	6-117
BZ588982	10-2x	ED491130	9-D2	ER324202	9-R2	ET571781	9-TR4	ML243540	6-87
BZ588993	10-3x	ED511918	8-D2	ER336442	7-R12	ET571781	9-TR8	ML251932	6-67
BZ589004	10-4x	ED514721	9-D3, 4	ER336442	7-R14	EV464196	7-VR1	ML256983	6-74
BZ589015	10-5x	ED514721	9-D6	ER336442	7-R21	EV464207	9-VR1	ML257040	6-79
BZ589094	10-63x	EF238634	10-45x	ER336442	9-R1	EV464220	7-VR3	ML257128	5-24
BZ589432	11-3x	EF277424	10-43x	ER336442	9-R3	EV480565	10-74	ML257163	6-84
EA579082	10-86x	EF304626	10-44x	ER336442	9-R11	EV520806	7-VR2	ML270685	6-50
EA583841	10-48x	EF375647	10-46x	ER336442	9-R31	EV522797	7-VR4	ML295727	6-81
EC220994	7-C12	EF563670	11-58x	ER339805	3-18	EV523620	9-VR2	ML308564	6-122x
EC220994	7-C36	EF563681	10-47x	ER342933	7-R15	EV603134	10-75	ML309093	6-43
EC220994	8-C13	EF575932	10-42x	ER343078	9-R12	EW315448	10-55x	ML475920	6-40
EC250841	8-C10, 11	EI412413	7-IC1, 2	ER343078	9-R20	EW516600	10-53x	ML479957	6-94
EC250841	10-85x	EJ205975	10-59	ER343078	9-R37	EW524845	10-54x	ML488744	5-2
EC251291	9-C11	EJ205986	6-116x	ER345712	10-81x	EW540112	10-52	ML493277	10-25
EC251291	9-C15, 16	EJ205986	10-61x	ER345712	10-97x	EZ225180	10-107x	ML548280	6-70
EC251291	9-C18	EJ229353	10-32x	ER346601	7-R7, 8	EZ225303	10-121	ML582355	5-5
EC290520	7-C6	EJ233370	10-40	ER346601	9-R7	EZ235113	10-16x	ML582366	5-6
EC290520	7-C24	EJ243191	6-124x	ER346601	9-R36	EZ246936	10-51x	ML607004	6-69
EC290520	7-C40	EJ254970	10-39x	ER346994	7-R11	EZ335204	3-7x	MP204794	6-113x
EC290520	9-C13	EJ255115	1-24	ER349907	7-R4	EZ382263	10-50	MP204794	11-49
EC320040	9-C12	EJ276963	1-27	ER349907	9-R13	EZ480396	8-2	MR217203	5-25
EC320051	7-C15	EJ277108	10-18	ER349907	9-R21, 22	EZ480418	8-4	MR217203	6-44
EC320051	7-C37 to 39	EJ297843	1-26	ER349907	9-R34	EZ480598	10-101	MR217203	6-80
EC320051	9-C1	EJ298607	10-104	ER349942	9-R19	EZ480600	10-102x	MR251460	2-12
EC320051	9-C4 to 6	EJ299823	6-123x	ER349942	9-R25	EZ480756	10-116x	MR252044	2-36
EC320051	9-C10	EJ299834	10-31x	ER349942	9-R30	EZ480780	10-123x	MR252055	2-38
EC320051	9-C14	EJ317125	6-114x	ER349942	9-R32, 33	EZ480824	10-20	MR252066	2-21
EC320051	9-C17	EJ350447	9-2	ER357456	9-R28	EZ480846	10-36	MR254496	3-15
EC329771	7-C23	EJ374027	8-J11	ER357535	9-R23	EZ481296	10-15	MR256094	2-34
EC329771	7-C26	EJ391083	10-68	ER357570	7-R20	EZ486865	10-124x	MR269728	5-3
EC329771	7-C33	EJ448075	10-106	ER357570	9-R14	EZ488957	10-105	MR269763	6-90
EC329861	9-C9	EJ602188	10-92	ER357570	9-R17	EZ489363	10-65	MR300644	3-17
EC329883	9-C7	EJ603145	10-77	ER361642	8-R2	EZ489677	10-91	MS243404	6-88
EC329883	10-83x	EL338196	10-87	ER361642	9-R38	EZ494853	10-7x	MS244708	4-3
EC336104	7-C2	EM480778	10-122	ER362485	7-R22	EZ527095	10-62x	MS245463	6-22
EC336104	7-C8, 9	EO244001	7-L2	ER364948	10-82x	EZ582423	10-88	MS245463	6-23x
EC336104	7-C34	EO321254	8-L1, 2	ER376413	10-19	EZ582434	10-89	MS255600	2-6
EC336115	8-C3	EO383365	8-T1	ER376424	6-34x	EZ582546	10-126	MS257051	6-11
EC336115	9-C20	EO390622	1-25	ER380711	7-R2	EZ582636	10-64	MS260515	6-41
EC336126	7-C4, 5	EO424866	7-L1	ER380711	7-R10	EZ583468	10-6	MS582906	6-91
EC336126	7-C14	EO496350	9-L1	ER380755	7-R30	EZ583817	10-33x	MT222366	2-13
EC336126	7-C20	ER211465	7-R5	ER380913	9-R40	EZ583852	10-49x	MT228598	2-45
EC336126	7-C30	ER211465	7-R32	ER398856	8-R4	EZ584021	10-76x	MT245215	6-63
EC336126	8-C9	ER211465	9-R39	ER413717	8-R3	HE384693	1-19	MT252101	2-20x
EC337500	9-C8	ER211667	7-R18	ER420322	7-R34	HL223503	1-30	MT252112	2-4x
EC337533	8-C1, 2	ER211667	9-R4	ER426857	9-R42, 43	HL223536	1-35	MT255420	2-8
EC350684	7-C18	ER211757	7-R33	ER429996	9-R6	HL312941	1-33	MT255565	2-10
EC350717	8-C4, 5	ER211757	9-R45	ER430097	9-R27	HP375131	1-12	MT255870	2-19
EC350875	8-C12	ER212174	9-R15	ER450011	7-R28	HP475446	1-16	MT255971	2-22
EC350875	9-C2	ER212264	7-R26, 27	ER450011	9-R35	HZ247511	6-13	MT255982	2-39x
EC368335	7-C10	ER212264	9-R10	ER450011	9-R44	HZ274162	1-4	MT255993	2-31
EC379157	7-C16	ER212264	9-R16	ER450101	10-96x	HZ312895	1-20	MT292386	2-29

INDEX

Parts No.	Ref. No. & Symbol No.	Parts No.	Ref. No. & Symbol No.	Parts No.	Ref. No. & Symbol No.	Parts No.	Ref. No. & Symbol No.	Parts No.	Ref. No. & Symbol No.
MT317463	2-5	SM578013	11-57x	ZS413201	6-14x	ZW290283	6-45		
MT368684	2-3	SM578250	10-95	ZS413201	6-48x	ZW290283	6-68		
MT438581	2-40x	SM605845	11-44	ZS413201	6-127	ZW290283	11-21x		
MT438592	2-25	SP578204	11-4	ZS413234	6-51x	ZW290294	6-107		
MT438603	2-26	SP578215	11-5x	ZS413245	6-101	ZW312693	2-42		
MT438614	2-41	SP578226	11-6x	ZS413728	5-12	ZW322525	6-106x		
MT438625	2-27x	SP582614	11-35	ZS414033	6-10x	ZW336846	1-32		
MT438636	2-24	SZ276816	11-8	ZS414044	6-15x	ZW376391	6-93x		
MT438647	2-23	SZ465377	6-3	ZS414336	11-40x	ZW376391	6-110x		
MT440313	2-44	SZ465388	6-7	ZS416687	5-23	ZW408418	11-31		
MT516565	2-7	SZ465388	11-30	ZS417150	4-18	ZW413188	6-18		
MV248117	6-5	SZ480712	11-17	ZS417150	6-20x	ZW413267	6-12x		
MV269965	4-24	SZ480982	10-119	ZS419736	4-28x	ZW413267	6-49x		
MV270066	5-21	SZ480993	10-120	ZS422076	6-33x	ZW413267	11-12x		
MV270066	6-129	SZ493042	5-37	ZS422965	6-31	ZW416698	10-14		
MY270055	4-11	SZ493042	11-22x	ZS424056	3-13	ZW419646	11-28x		
MY270055	11-59	SZ609952	11-13	ZS425788	6-119x	ZW432347	5-28		
MZ217113	6-99	UC254250	3-3	ZS427026	3-14	ZW432347	6-85		
MZ217293	5-22	ZG206144	1-11	ZS427037	3-8	ZW432347	11-53x		
MZ217293	6-128	ZG208091	6-57	ZS433001	11-56x	ZW434193	5-20x		
MZ217708	6-52	ZG217394	4-19x	ZS434160	2-46	ZW434215	5-19x		
MZ217855	6-96	ZG217394	6-125	ZS434160	11-47x	ZW437804	2-30		
MZ225720	5-31	ZG217866	6-97	ZS434171	2-35	ZW447208	4-5		
MZ229138	10-60	ZG227417	6-92	ZS434250	10-12x	ZW455275	10-108x		
MZ248354	4-16	ZG227428	10-23	ZS434283	11-29x	ZW462835	6-36x		
MZ253113	4-10	ZG227441	6-76	ZS447840	10-94	ZW462846	6-37x		
MZ253653	6-47	ZG227452	6-75	ZS461935	10-22x	ZW462857	6-38x		
MZ253956	3-6x	ZG227485	5-36	ZS464714	1-10	ZW462868	6-39x		
MZ254351	3-10	ZG227485	6-54x	ZS480622	1-34	ZW463410	4-27		
MZ256814	6-56x	ZG227542	2-37x	ZS483456	11-39x	ZW476155	11-14x		
MZ257073	6-19	ZG227553	2-14	ZS575976	11-23x	ZW481072	11-50x		
MZ259233	10-58x	ZG227575	6-55	ZS600816	3-16	ZW516611	1-6		
MZ259233	10-111x	ZG227586	5-17	ZW217102	6-100	ZW526577	11-34		
MZ260662	6-77	ZG255633	2-9	ZW231693	2-28	ZW527670	11-45x		
MZ271776	6-8	ZG257095	6-21	ZW231805	6-4	ZW554624	10-109		
MZ293567	6-59	ZG270358	6-83	ZW235585	4-23	ZW562476	10-79		
MZ293578	6-60	ZG290384	6-73	ZW252977	4-13x	ZW588306	2-32		
MZ296267	4-6	ZG312928	1-31	ZW254621	3-9				
MZ312524	6-24	ZG414077	2-43	ZW259918	6-72x				
MZ312535	6-25	ZG465478	4-17	ZW259942	6-65x				
MZ312748	6-58	ZG469427	6-46	ZW259975	6-89x				
MZ316901	5-8	ZS200610	11-20x	ZW260021	2-15				
MZ316945	5-11	ZS201475	1-14	ZW260054	2-16				
MZ316956	5-13	ZS201767	6-71x	ZW260054	4-20x				
MZ316956	6-126	ZS207314	10-26	ZW260054	6-53x				
MZ317068	5-34	ZS217877	5-27	ZW260065	2-17x				
MZ327341	5-16	ZS217877	6-95	ZW260076	6-109x				
MZ327352	5-18	ZS223233	6-86	ZW260087	6-82x				
MZ395144	3-2	ZS245801	6-64x	ZW260098	2-18x				
MZ395166	3-5	ZS253405	11-52x	ZW260122	5-33x				
MZ396393	6-115x	ZS293027	4-12	ZW260133	5-15x				
MZ446635	4-8	ZS293027	11-60	ZW260133	6-66x				
MZ452496	6-120x	ZS322626	1-7	ZW260144	6-112				
MZ585887	6-28	ZS323728	1-18	ZW260201	11-54x				
MZ585900	4-26	ZS323728	6-30	ZW270088	2-11				
MZ585911	4-25	ZS323728	10-30	ZW270191	10-70				
MZ586798	4-7x	ZS323728	10-72	ZW272722	10-69x				
MZ599038	10-67x	ZS323728	11-33x	ZW273723	1-22				
MZ606993	6-32	ZS324448	11-16x	ZW273734	1-23				
MZ610457	5-35	ZS325495	8-5	ZW273756	10-24x				
MZ610457	6-98	ZS325495	10-17	ZW273756	10-117x				
SA377190	11-27x	ZS325495	10-27x	ZW273767	6-78				
SB258478	6-102	ZS325495	10-66	ZW273802	1-5				
SB485741	6-118	ZS325495	10-103x	ZW273802	10-35x				
SC607015	11-43	ZS325495	10-118	ZW273802	10-80x				
SE330895	11-10	ZS327835	11-9x	ZW273802	10-113x				
SE382217	11-15x	ZS327835	11-26x	ZW273881	10-34x				
SE578125	11-36	ZS349288	1-28	ZW273881	10-112x				
SE582480	11-38	ZS349288	3-19	ZW273892	5-29x				
SE582557	11-25	ZS349288	6-29x	ZW273914	6-35x				
SE582568	11-24	ZS349288	6-61x	ZW273914	10-13x				
SE583255	11-37	ZS349288	10-57x	ZW273960	5-30				
SK314100	11-55	ZS373577	4-4	ZW273960	6-42x				
SK476684	11-51	ZS379405	1-36	ZW274048	6-6x				
SK485651	11-46	ZS379405	8-3	ZW290248	10-127				
SK576628	11-41	ZS379405	10-41	ZW290248	11-18x				
SK583132	11-48	ZS384131	3-4x	ZW290250	11-19x				
SK583266	11-42	ZS393726	6-26	ZW290283	4-21x				
SM223817	10-29	ZS411660	11-32	ZW290283	5-4x				
SM489611	11-7	ZS413201	5-14	ZW290283	5-26				

For Service Manuals Contact
MAURITRON TECHNICAL SERVICES
 8 Cherry Tree Rd, Chinnor
 Oxon OX9 4QY
 Tel:- 01844-351684 Fax:- 01844-352554
 Email:- enquiries@mauritron.co.uk

For Service Manuals Contact
MAURITRON TECHNICAL SERVICES
8 Cherry Tree Rd, Chinnor
Oxon OX9 4QY
Tel:- 01844-351694 Fax:- 01844-352554
Email:- enquiries@mauritron.co.uk

SECTION 3

SCHEMATIC DIAGRAM

4000DB SCHEMATIC DIAGRAM

4000DB

For Service Manuals Contact
MAURITRON SERVICES
8 Cherry Tree Rd, Crinnor
Oxon OX9 4QY
Tel: 01844-351854 Fax: 01844-352554
Email: enquiries@mauritron.co.uk

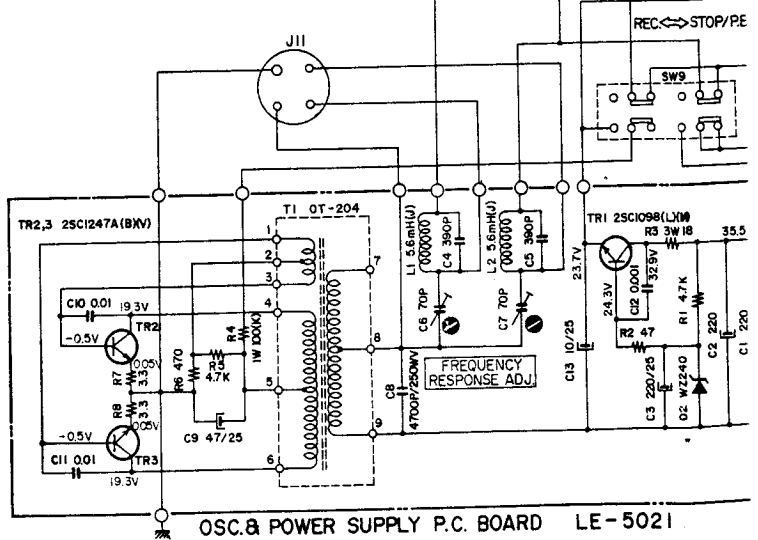
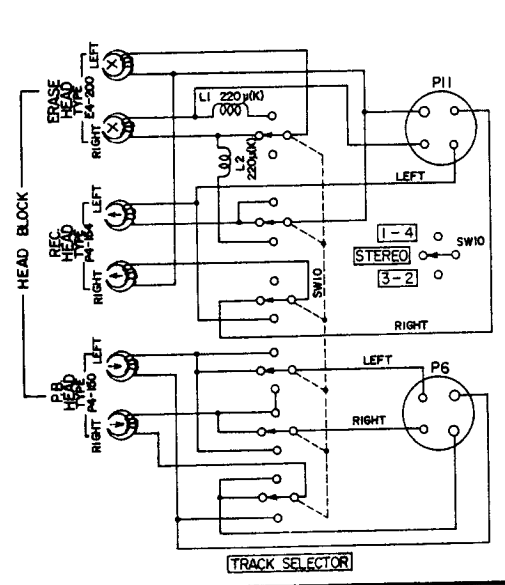
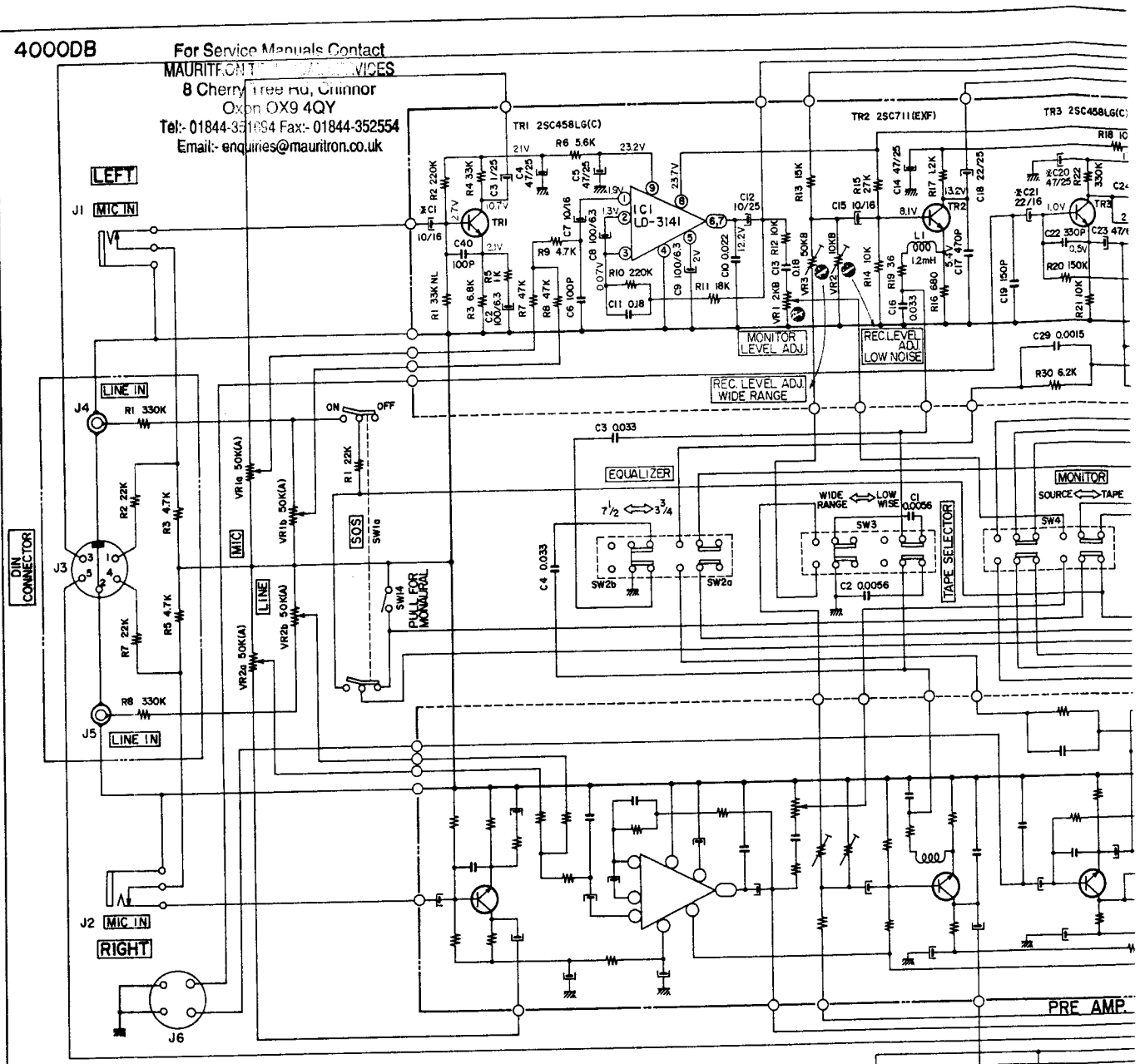

OSC. & POWER SUPPLY P.C. BOARD LE-5021

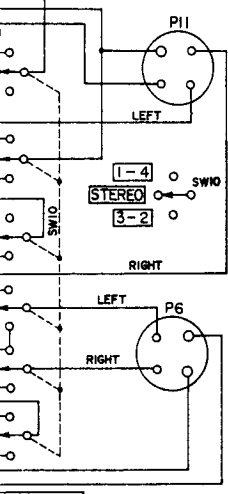
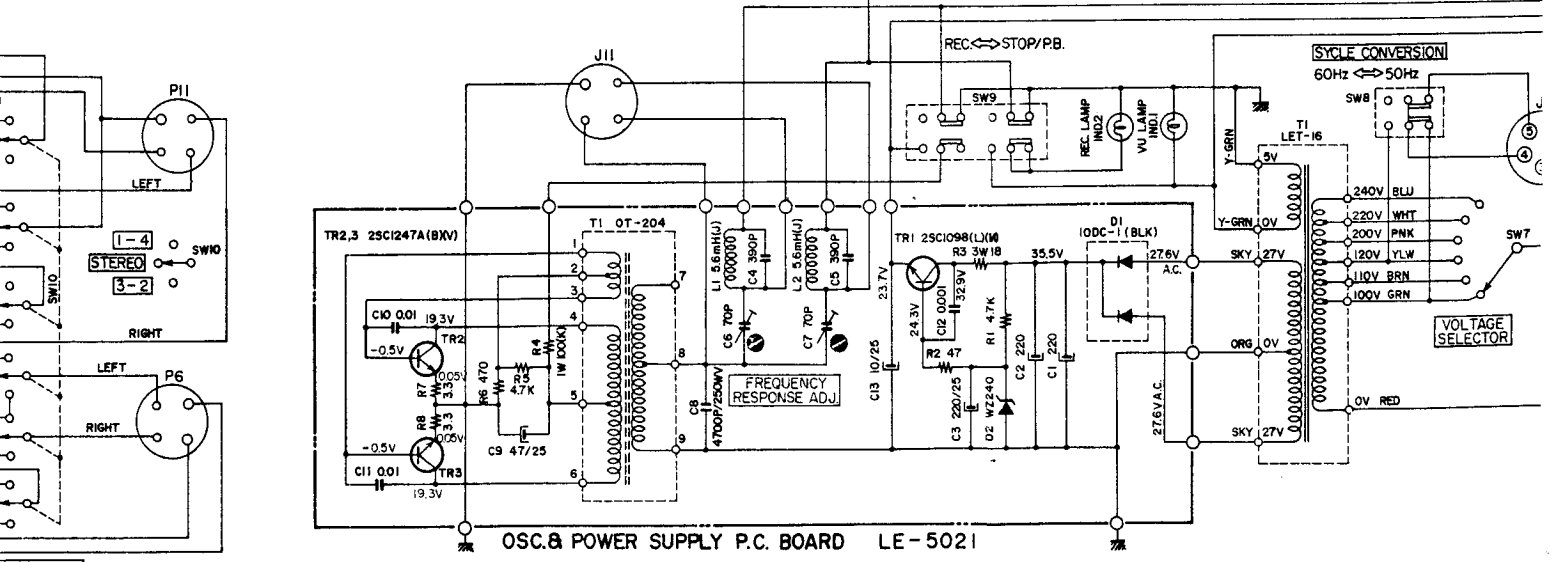
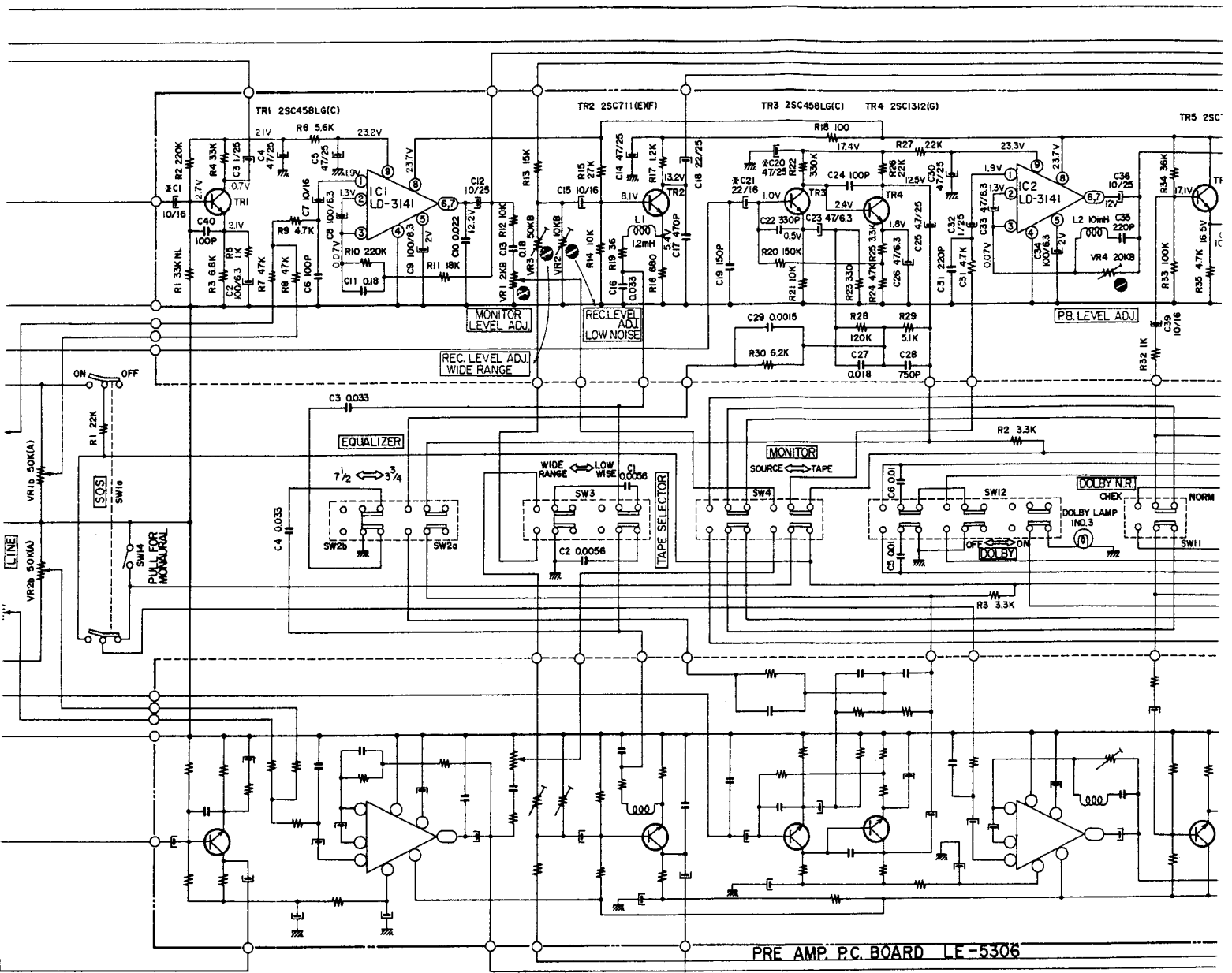

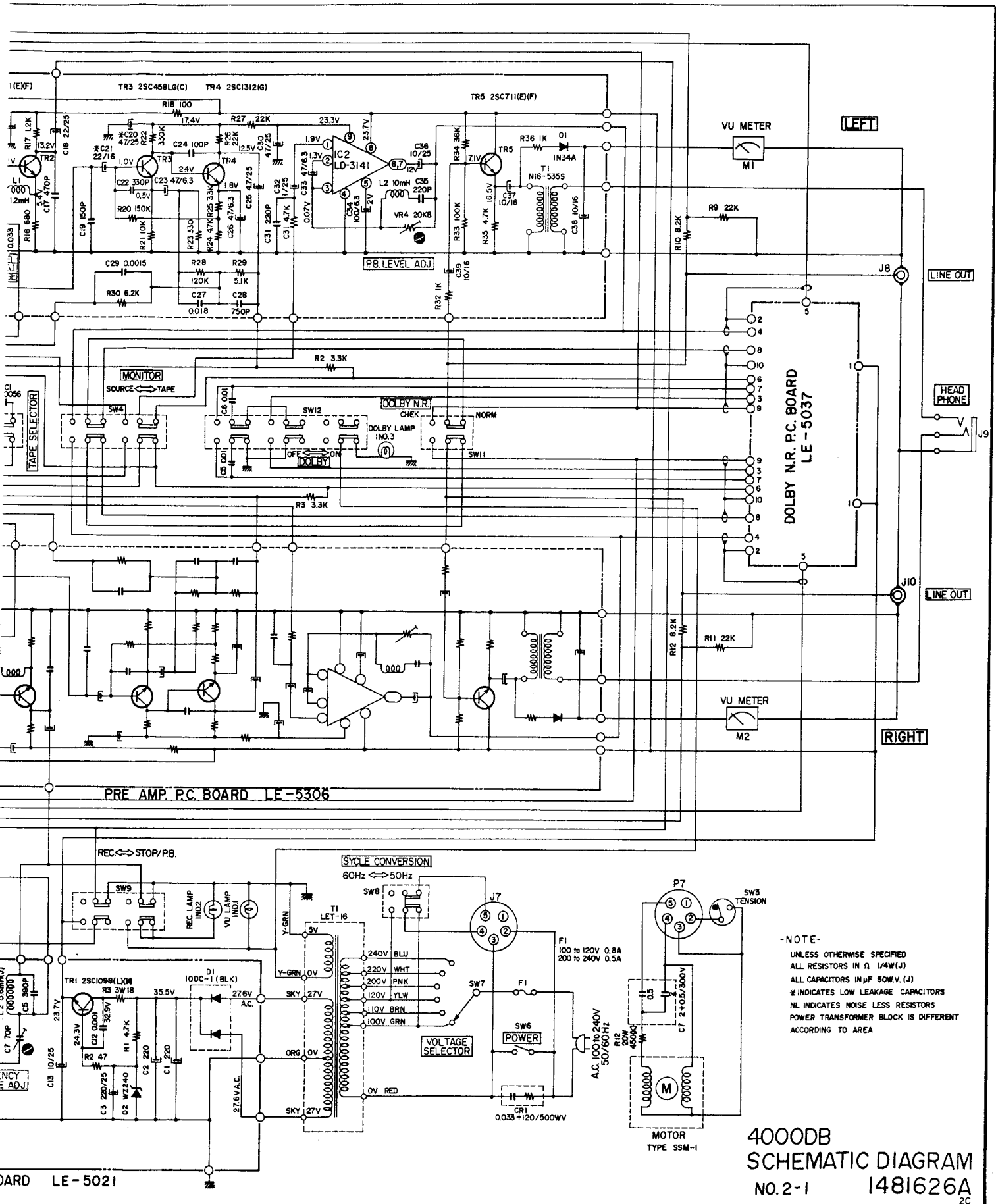

-NOTE-
 UNLESS OTHERWISE SPECIFIED
 ALL RESISTORS IN Ω 1/4W(J)
 ALL CAPACITORS IN μ F 50WV.(J)
 * INDICATES LOW LEAKAGE CAPACITORS
 NL INDICATES NOISE LESS RESISTORS
 POWER TRANSFORMER BLOCK IS DIFFERENT
 ACCORDING TO AREA

For Service Manuals Contact
MAURITRON TECHNICAL SERVICES
 8 Cherry Tree Rd, Chinnor
 Oxon OX9 4QY
 Tel: 01844-351694 Fax: 01844-352554
 Email: enquiries@mauritron.co.uk

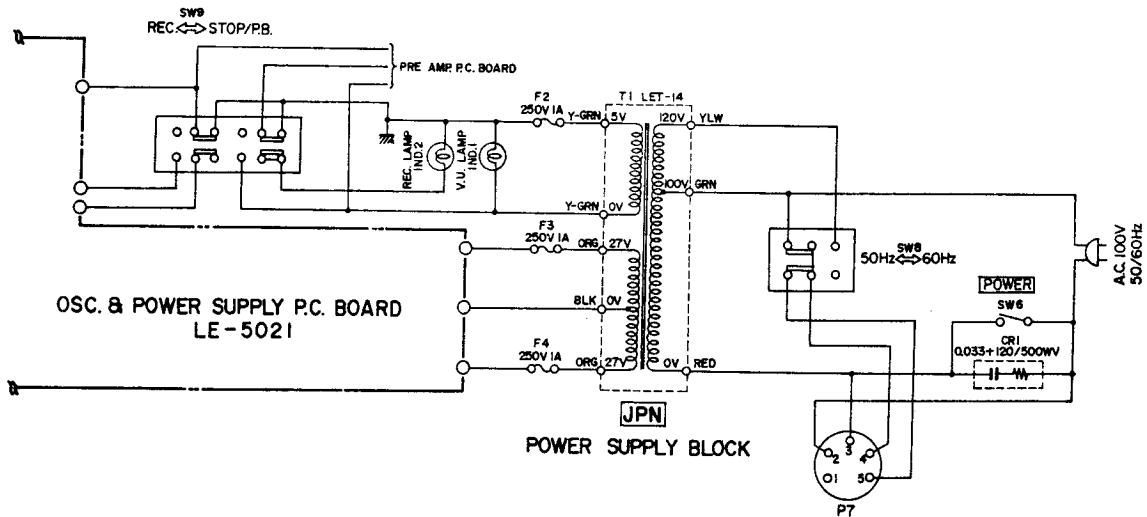
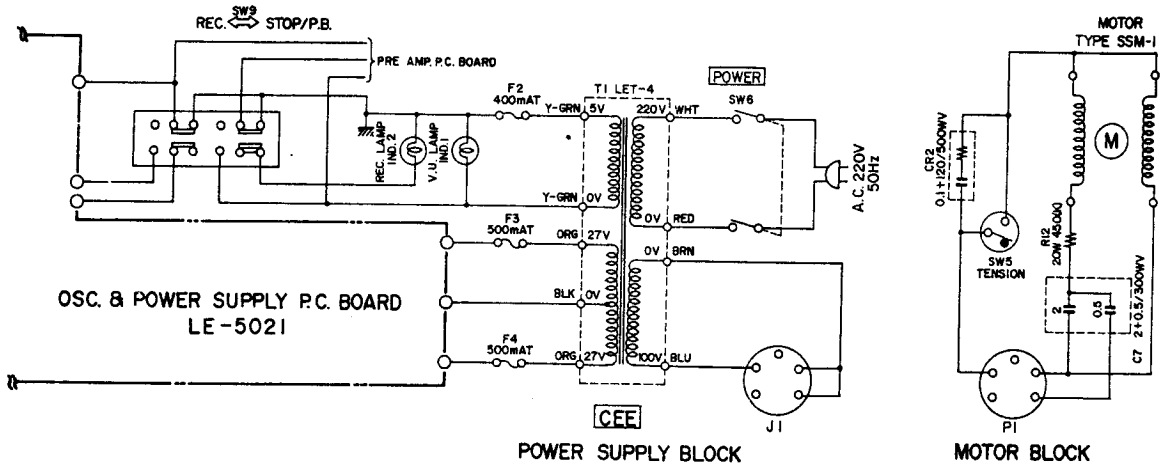
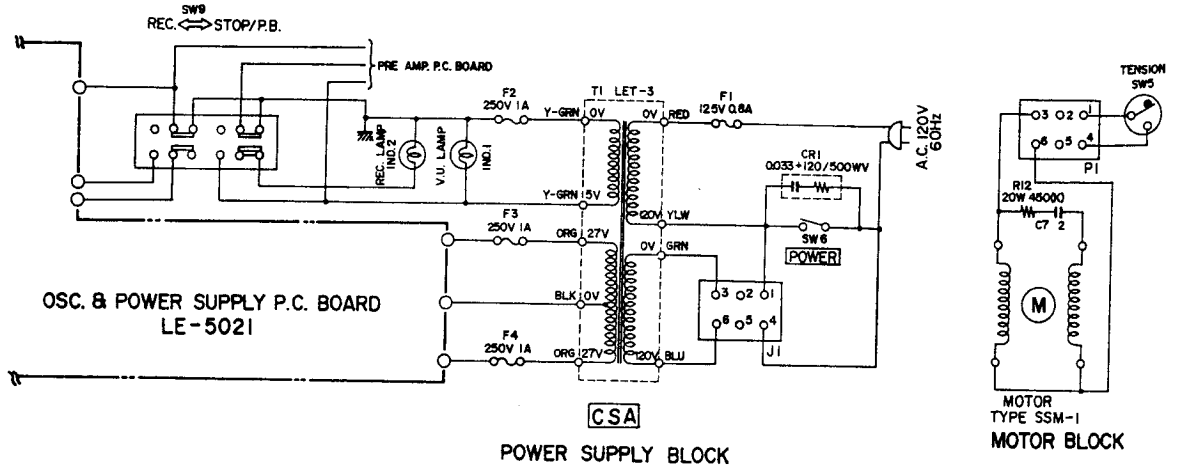

For Service Manuals Contact
MAURITRON TECHNICAL SERVICES
 8 Cherry Trees Rd, Chinnor
 Oxon OX9 3DF

Tel: 01844 319554
 Email: enquiries@mauritron.co.uk

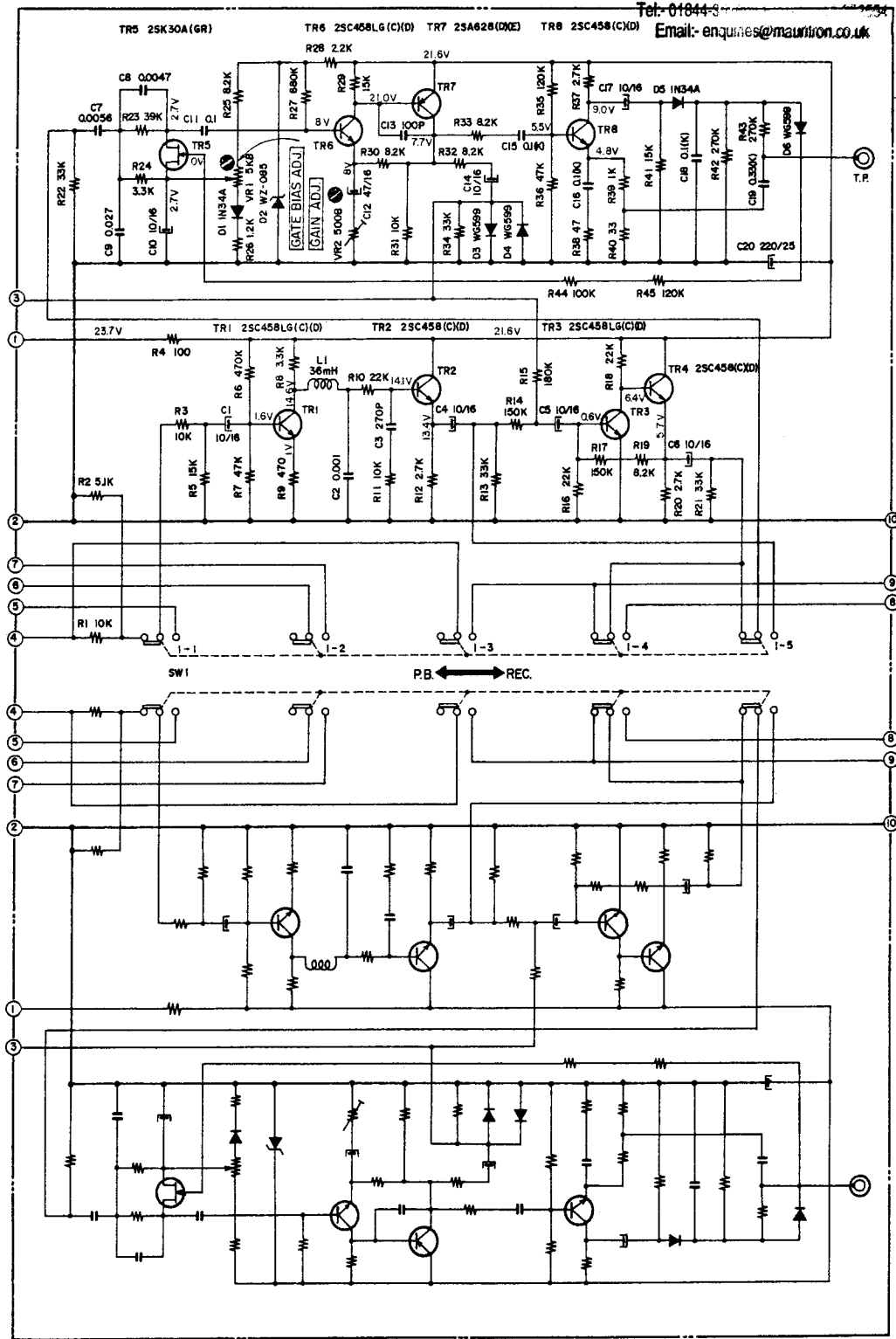

DOLBY N.R. P.C. BOARD LE-5037

NOTE
 UNLESS OTHERWISE SPECIFIED
 ALL RESISTORS IN Ω 1/4W(J)
 ALL CAPACITORS IN μ F 50WV(J)

4000DB
SCHEMATIC DIAGRAM
 NO.2-2 1481627A
 2C