

# SERVICE MANUAL

## PARTS LIST

### *RTV servis Horvat*

Kešinci, 31402 Semeljei

Tel : 031-856-637

Tel / fax : 031-856-139

Mob : 098-788-319

[rtv-servis-horvat@os.tel.hr](mailto:rtv-servis-horvat@os.tel.hr)

**MODEL AA-1010L**

**AKAT**



**AKAI STEREO RECEIVER**

**MODEL AA-1010L**

<b>SECTION 1</b>	<b>SERVICE MANUAL</b>	<b>1</b>
<b>SECTION 2</b>	<b>PARTS LIST</b>	<b>27</b>
<b>SECTION 3</b>	<b>SCHEMATIC DIAGRAM</b>	<b>36</b>

---

SECTION 1

**SERVICE MANUAL**

TABLE OF CONTENTS

I.	TECHNICAL DATA .....	2
II.	DISMANTLING OF UNIT .....	4
III.	CONTROLS .....	5
IV.	PRINCIPAL PARTS LOCATIONS .....	5
V.	VARACTOR TUNER AND PRESET TUNING SYSTEM .....	6
	1. VARACTOR TUNER .....	6
	2. PRESET TUNING SYSTEM .....	9
VI.	TUNER ADJUSTMENT .....	10
	1. FM SECTION ADJUSTMENT .....	10
	2. LW SECTION ADJUSTMENT .....	12
	3. MW SECTION ADJUSTMENT .....	13
VII.	MAIN AMP ADJUSTMENT .....	14
VIII.	TUNING CORD THREADING .....	15
IX.	CLASSIFICATION OF VARIOUS P.C BOARD .....	16
	1. RELATION OF P.C BOARD TITLE AND IDENTIFICATION NUMBER .....	16
	2. COMPOSITION OF VARIOUS P.C BOARD .....	17

For basic adjustments, measuring methods, and operating principles, refer to GENERAL OPERATING PRINCIPLES AND ADJUSTMENTS.

# I. TECHNICAL DATA

## POWER AMPLIFIER SECTION

CONTINUOUS POWER OUTPUT 2-CHANNELS DRIVEN		14 Watts per channel, minimum RMS, at 8 ohms from 40 to 20,000 Hz with no more than 0.8% total harmonic distortion.
POWER BANDWIDTH (IHF)		15 Hz to 40 kHz/8 ohms, distortion within 0.8%
SIGNAL TO NOISE RATIO (IHF)	PHONO AUX	Better than 75 dB Better than 90 dB
RESIDUAL NOISE		Less than 0.8 mV at 8 ohms
CHANNEL SEPARATION (IHF)	PHONO	Better than 50 dB at 1,000 Hz
DAMPING FACTOR		More than 30 (1 kHz, 8 ohms)
OUTPUT	SPEAKERS HEADPHONE	A, B (4 to 16 ohms)/A+B (8 to 16 ohms) 4 to 16 ohms

## PRE AMPLIFIER SECTION

INPUT SENSITIVITY/IMPEDANCE	PHONO AUX TAPE MONITOR	3 mV/47 k ohms 150 mV/100 k ohms PIN: 150 mV/100 k ohms DIN: 30 mV/180 k ohms
OUTPUT LEVEL/IMPEDANCE	TAPE REC	PIN: 150 mV/100 k ohms DIN: 150 mV/100 k ohms
FREQUENCY RESPONSE	PHONO (RIAA) TUNER/AUX/TAPE MONITOR	30 Hz to 15 kHz $\pm 1$ dB 10 Hz to 70 kHz +0 dB, -2 dB
TONE CONTROL	BASS TREBLE	$\pm 10$ dB at 100 Hz $\pm 10$ dB at 10 kHz
LOUDNESS CONTROL		+10 dB at 100 Hz, +5 dB at 10 kHz (Volume control set at -30 dB position)

## FM TUNER SECTION

FREQUENCY RANGE		88 MHz to 108 MHz
SENSITIVITY (IHF)		2.0 $\mu$ V
CAPTURE RATIO		1.5 dB
SELECTIVITY (IHF)		More than 60 dB
IMAGE REJECTION		More than 55 dB (98 MHz)
IF REJECTION		More than 70 dB (98 MHz)
SPURIOUS REJECTION		More than 70 dB (98 MHz)
AM SUPPRESSION		50 dB
SIGNAL TO NOISE RATIO		60 dB
HARMONIC DISTORTION	MONO STEREO	Less than 0.3% (100% modulation) Less than 0.6% (100% modulation)
TUNING INDICATOR		Center Tuning meter and Frequency Indicator meter
STEREO SEPARATION		More than 40 dB (1 kHz)
SUBCARRIER SUPPRESSION		More than 50 dB
ANTENNA INPUT IMPEDANCE		300 ohms balanced, 75 ohms unbalanced

---

**AM TUNER SECTION**

FREQUENCY RANGE	MW: 520 kHz to 1,605 kHz LW: 150 kHz to 350 kHz
SENSITIVITY (IHF)	MW: 200 $\mu$ V/m (bar antenna) 20 $\mu$ V (ext. antenna) LW: 300 $\mu$ V/m (bar antenna) 30 $\mu$ V (ext. antenna)
SELECTIVITY (IHF)	MW: More than 30 dB LW: More than 30 dB
IMAGE REJECTION	MW: More than 55 dB (1 MHz) LW: More than 35 dB (240 kHz)
IF REJECTION	MW: More than 45 dB LW: More than 40 dB
SIGNAL TO NOISE RATIO	MW: More than 45 dB, LW: More than 50 dB

**MISCELLANEOUS**

SEMI-CONDUCTORS	Transistors: 27, Diodes: 25, FETs: 2, ICs: 6
POWER REQUIREMENTS	CSA, UL and LA models: 120V, 60 Hz CEE models: 220V, 50 Hz Other models: 110/220/240V, 50/60 Hz switchable
DIMENSIONS	440(W) x 125(H) x 265(D)mm (17.3 x 4.9 x 10.4")
WEIGHT	6.2 kg (13.7 lbs)

\* For improvement purposes, specifications and design are subject to change without notice.

## II. DISMANTLING OF UNIT

In case of trouble, etc. necessitating disassembly, please disassemble in the order shown in photographs. Reassemble in reverse order.

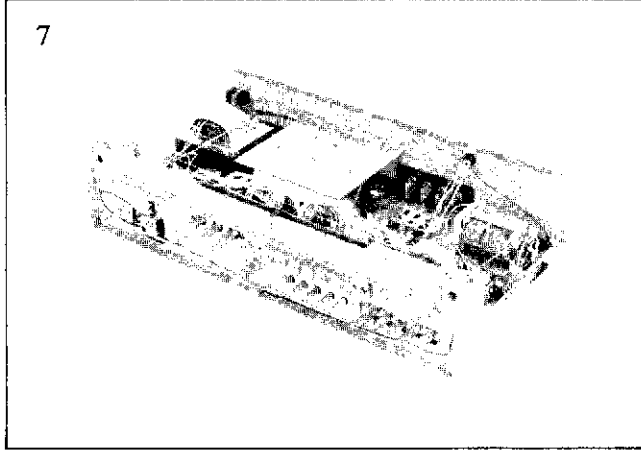
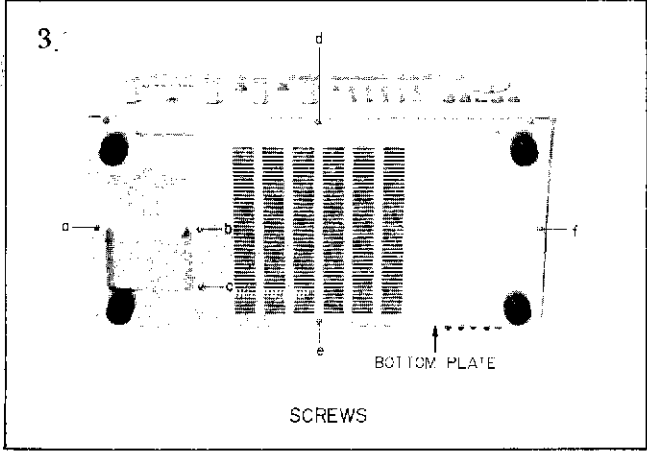
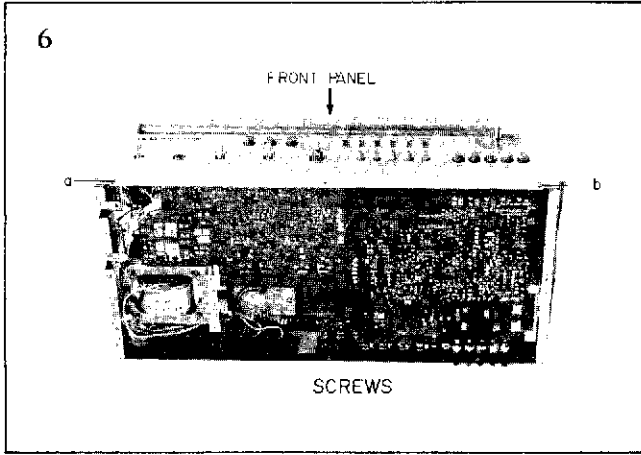
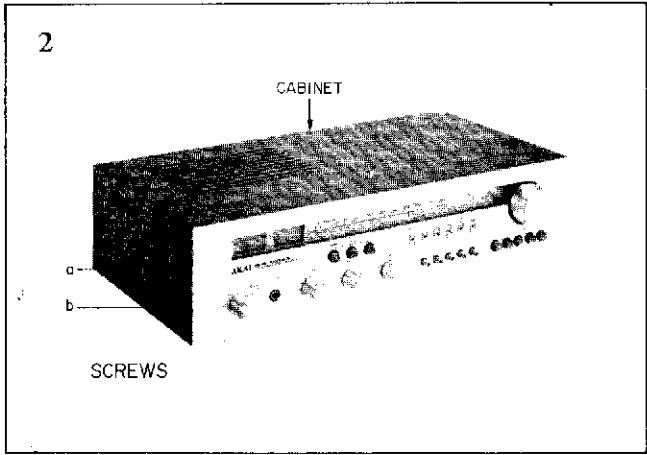
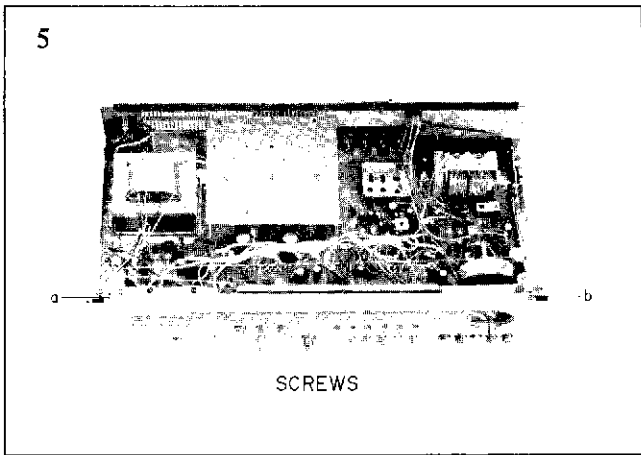
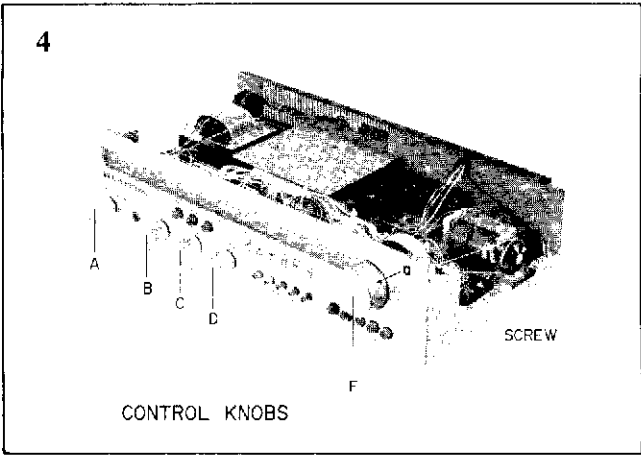

### III. CONTROLS

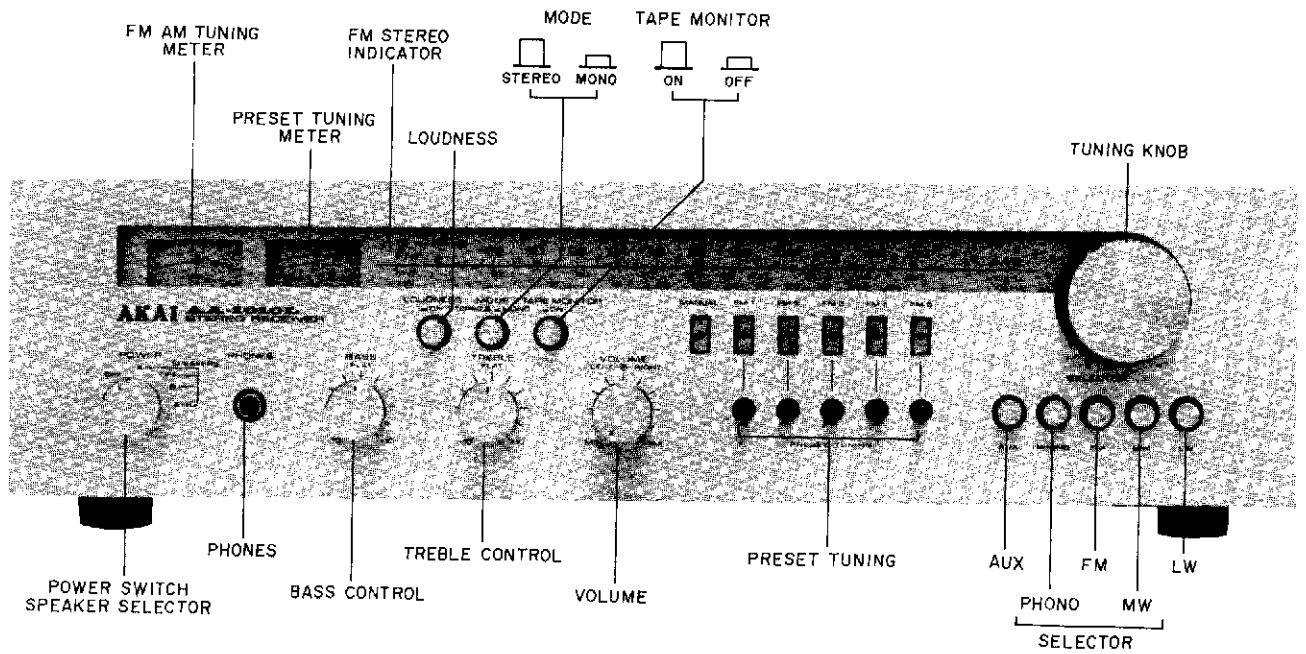

Fig. 1 Controls

### IV. PRINCIPAL PARTS LOCATION

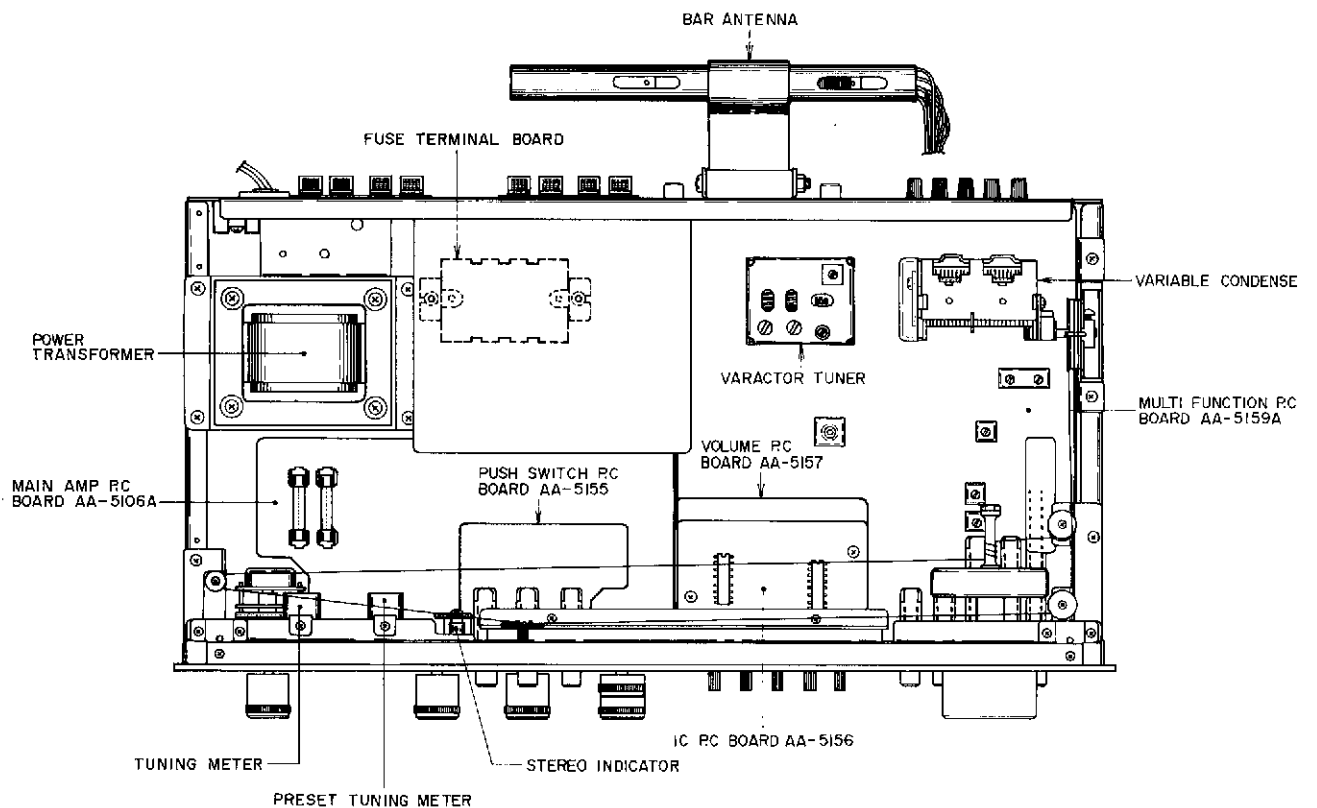

Fig. 2 Top View

# V. VARACTOR TUNER AND PRESET TUNING SYSTEM

## 1. VARACTOR TUNER

A varactor tuner is the tuner system in which varactor diode junction capacitance is varied by means of the inverse bias value applied to the diode for station selection. By employing a varactor diode, tuning which is same as ordinary variable condenser system can be made without using a variable condenser by changing control voltage only.

### 1) Features

- a) When used in an FM tuner, the front end can be made smaller than when compared with a variable condenser.
- b) Station selector button positioning is not limited.

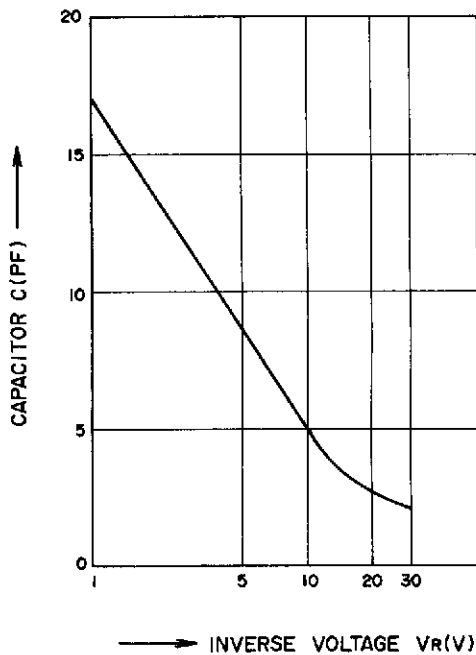

Fig. 3

- c) Station selection by remote control is possible.
- d) Ideal voltage can be set for a certain reception frequency beforehand, and preset tuning can be effected by successively switching the control voltage.
- e) If control voltage sweep is at ideal speed, automatic tuning (search tuning) is possible.
- f) Power consumption is about the same as a variable condenser system.

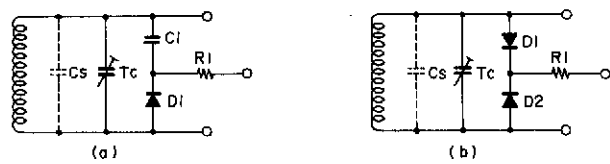

Fig. 4 Tuning circuit employing a varactor diode

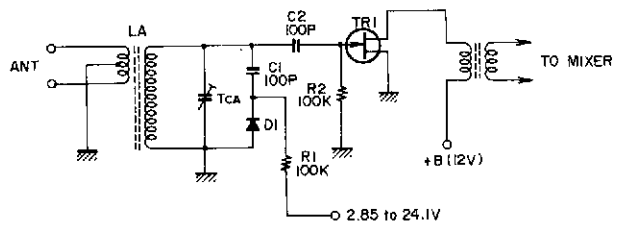

Fig. 5 Example of High Frequency Amplifier Stage Circuit

### 2) Varactor Diode Characteristics

As for varactor diode characteristics, as shown in Fig. 3, capacitance C is changed by change in inverse voltage Vr. Further, if this varactor diode is used in a tuning circuit, the following conditions are necessary.

$$\frac{C_{\max} + C_D}{C_{\min} + C_D} = \left( \frac{f_{\max}}{f_{\min}} \right)^2 = K$$

C<sub>max</sub>, C<sub>min</sub> are the maximum and minimum values of varactor diode capacitance change. C<sub>D</sub> is the sum of stray capacitance and trimmer capacitance. K is over 1.5 because FM broadcast frequency range is 88 to 108 MHz. Figs 4(a) and 4(b) show the actual usage method.



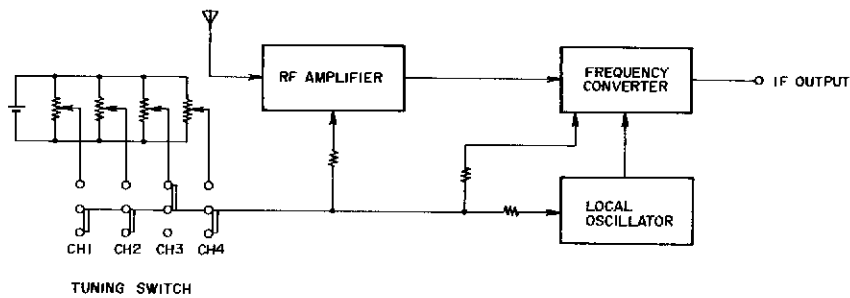

Fig. 6 Block Diagram

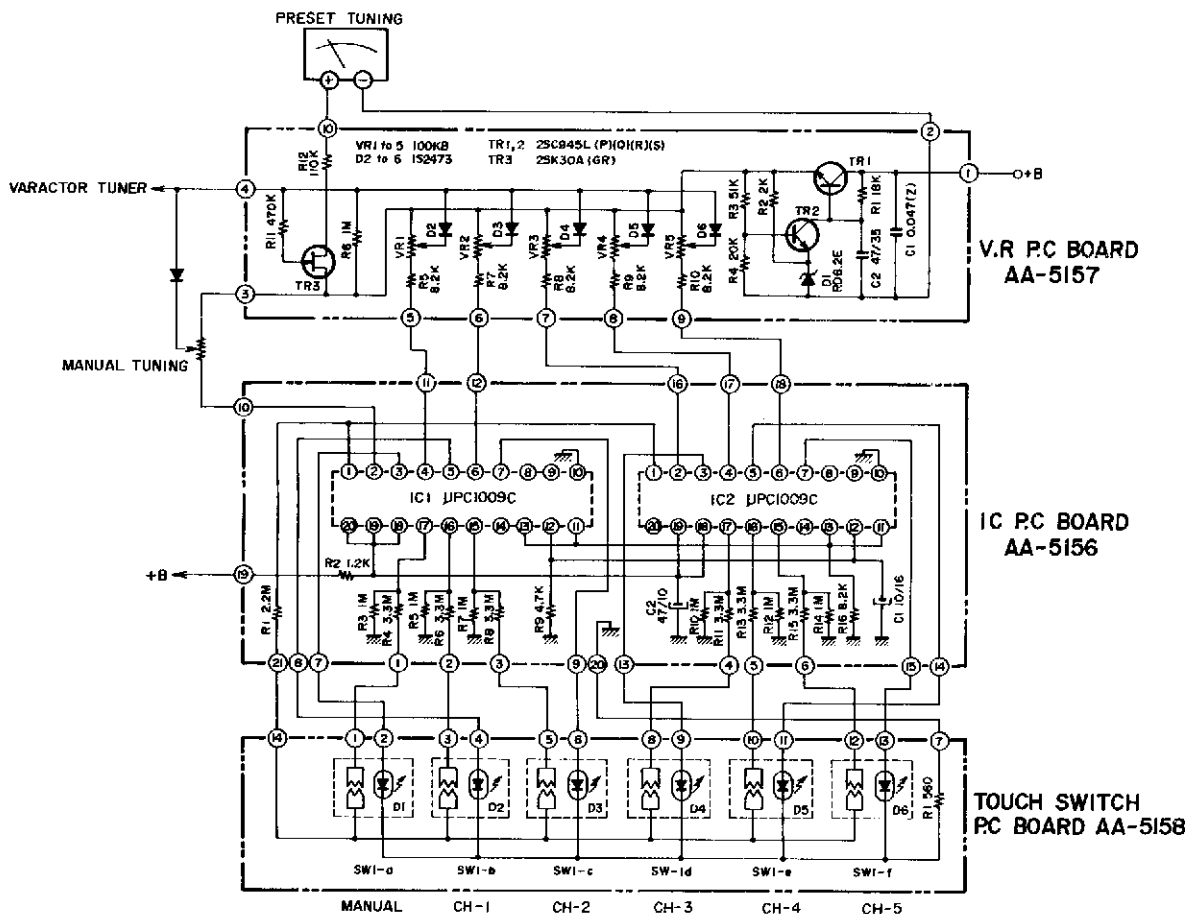

Fig. 7

### 3) Actual Operation

Fig. 5 is a circuit diagram of the high frequency amplifier stage only of a circuit which is actually used. Condenser C1 and varactor diode D1 in the diagram are equivalent to the variable condenser of an ordinary FM front end. As can be understood from Fig. 3, D1 varies the capacitance in a 4 to 16 PF range by means of inverse bias voltage. This capacitance and condenser C1 combined capacitance forms the resonance circuit with coil LA. Consequently, it is satisfactory if at low resonance frequency, the voltage supplied to the varactor diode declines, and at high resonance frequency, the voltage supplied to the varactor diode increases. This voltage variation method with variable resistor, etc., operates in the same way as a regular variable condenser.

This method uses a local oscillator circuit and frequency mixer circuit, and bias voltage is applied to the varactor diode for station selection and is called a varactor tuner. Please refer to the schematic diagram for actual circuit drawing.

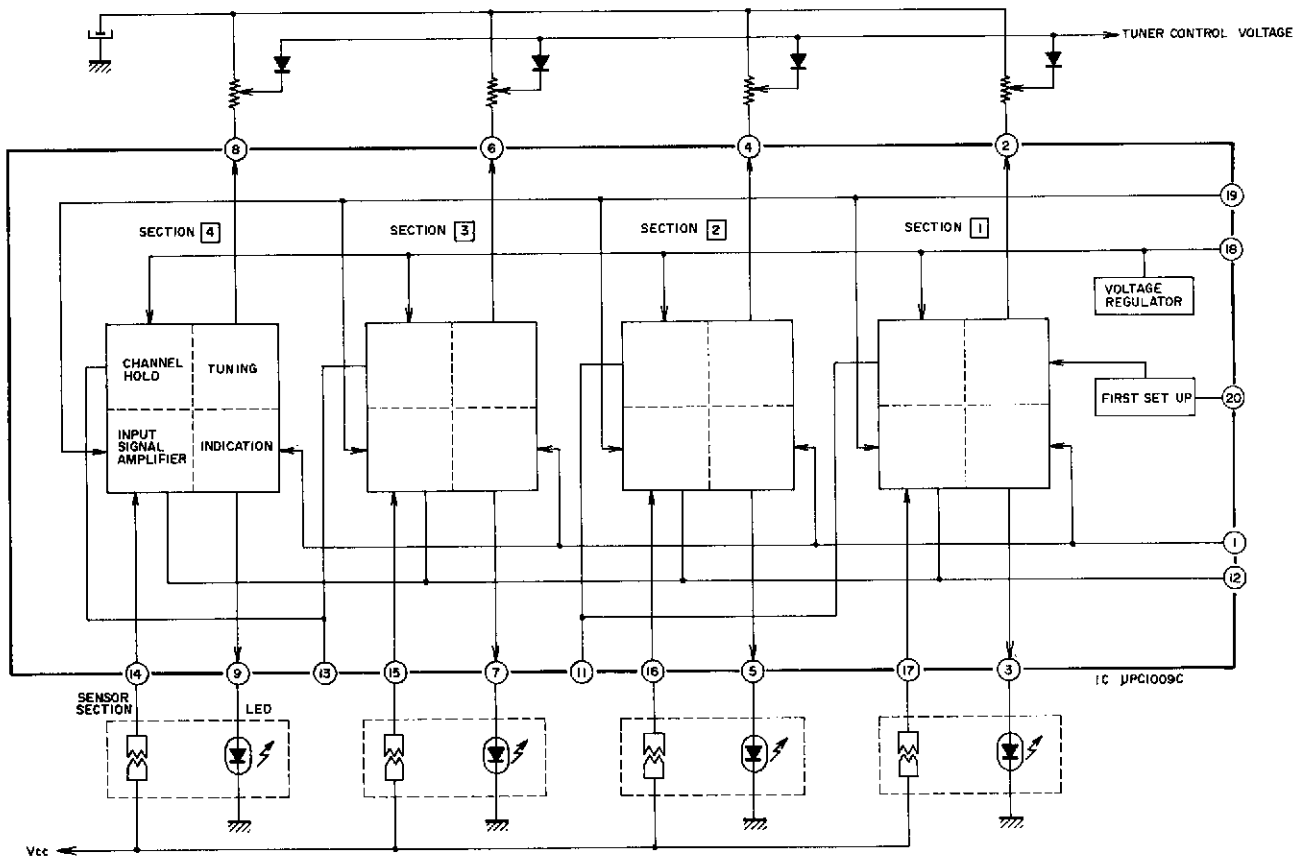

Fig. 8

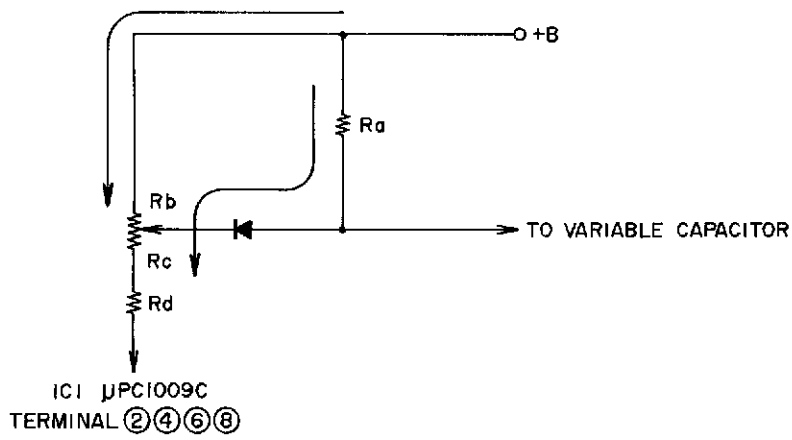

Fig. 9

---

## 2. PRESET TUNING SYSTEM

### 1) Preset Station Selection

For preset station selection, there is a mechanical and an electrical method. These are memory equipment and selection equipment enabling desired station selection beforehand and selecting these pre-set stations by simply depressing the respective switches.

An ordinary car radio, etc. utilizes a mechanical station selection system wherein mechanical variation is by means of a variable condenser or positioning of a dust core inside a coil.

Model AA-1010L utilizes an electrical station selection system and employs the varactor tuner explained in a previous item.

- 2) An example of a station selection system employing a varactor tuner is shown in Fig. 6. For station selection, push switches are used for selection of voltage supply to the varactor tuner. However, in the AA-1010L, these station selection push switches are pure electronic system sensi-touch switches.

### 3) Sensi-touch Employed Preset Station Selection System Operation

The circuit shown in Fig. 7 is the control voltage generating preset volume and sensi-touch circuit. Fig. 8 shows the inside of circuit sensi-touch IC  $\mu$ PC1009C which include the 4 channel circuitry. Terminals 14 through 17 are the input terminals; terminals ②, ④, ⑥, and ⑧ are the station selection output terminals; and terminals ③, ⑤, ⑦, and ⑨ are the pilot output terminals. When channel 1 sensor electrode is touched, voltage is supplied to the IC as the input signal through finger (body) resistance at terminal ⑰. Then, the impedance is lowered at IC station selector output terminal ② and current flows as shown by the arrow marks in Fig. 9. Consequently, because the supply voltage to the varactor tuner diode is changed by the dividing ratio of  $R_b$  and  $R_c$ , station selection is possible by means of setting the preset volumes beforehand according to the desired broadcast frequencies.

---

# VI. TUNER ADJUSTMENT

MULTI FUNCTION P.C BOARD AA-5159A

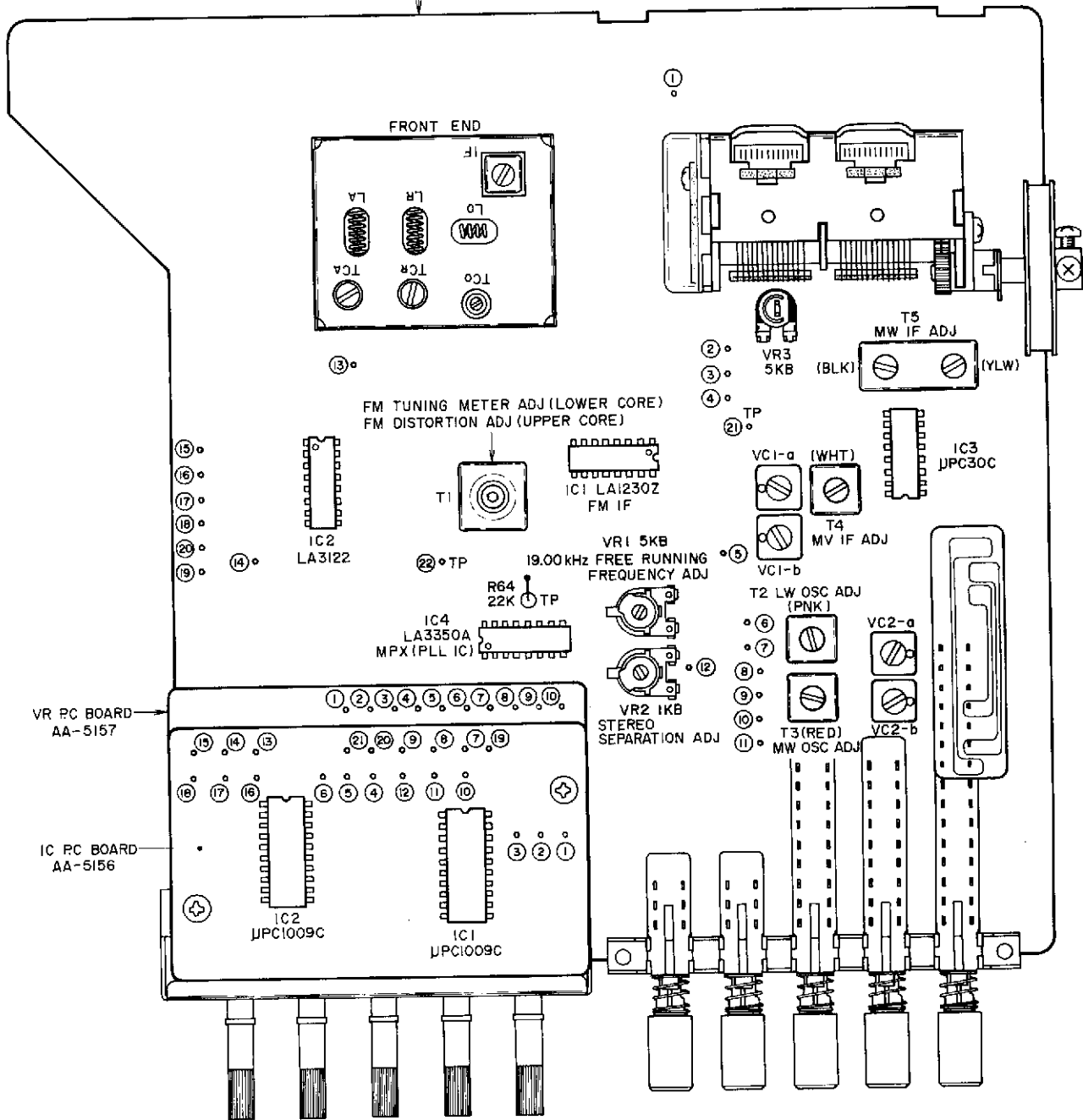

Fig. 10 Multi Function P.C Board AA-5159A

## 1. FM SECTION ADJUSTMENT (Refer to Fig. 10)

Step	Adjustment Item	Adjustment Point	Result	Remarks
1	Front End IF Coil Adjustment	IF Coil (Front End)	Maximum noise level	Depress FM Selector. Tune only noise without interference of broadcasts.
2	Tuning Meter Centering Adjustment	T1 lower side core (Multi-Function P.C Board AA-5159A)	Center indication of tuning meter	Same as above
3	Distortion Factor Adjustment	T1 upper side core (Multi-Function P.C Board AA-5159A)	Less than 0.3% distortion factor	108 MHz, 60 dB (mono) input. Less than 0.3% distortion factor, both channels.

Step	Adjustment Item	Adjustment Point	Result	Remarks
4	Confirmation of Tuning Meter Indication			If Tuning Meter indication is not at center position, repeat steps 2 and 3 above.
5	High Range Frequency Coverage Adjustment	TCO trimmer condenser (Front End)		108 MHz, 60 dB(mono) input. Error: Within $\pm 250$ kHz.
6	High Range Sensitivity Adjustment	TCR, TCA trimmer condensers (Front End)	Less than 3.0% distortion factor	108 MHz, Less than 12 dB (mono) input.
7	Low Range Frequency Coverage Adjustment	VR3, 5 k $\Omega$ (Multi-Function P.C Board AA-5159A)		88 MHz, 60 dB (mono) input. Error: Within $\pm 250$ kHz.
8	Low Range Sensitivity Confirmation		Less than 3.0% distortion factor	88 MHz, Less than 12 dB (mono) input. Refer to Note 1.
9	Mid-Range Sensitivity Confirmation		Less than 3.0% distortion factor	98 MHz, Less than 12 dB (mono) input. Error: Within $\pm 250$ kHz. Refer to Note 1.
10	PLL IC Free Running Frequency Adjustment	VR1, 1 k $\Omega$ (Multi-Function P.C Board AA-5159A)	19.00 kHz	Connect Frequency Counter to R64 22 k ohms. Refer to Note 2.
11	Stereo Indicator Lighting Confirmation			98 MHz, 60 dB (stereo) input. When the stereo indicator fails to light, this means that broadcast is not being received in stereo.
12	Stereo Separation Adjustment	VR2, 1 k $\Omega$ (Multi-Function P.C Board AA-5159A)	Better than 40 dB	98 MHz, 60 dB (stereo) left channel input. Distortion Factor must be less than 0.6%.
13	Stereo Separation Adjustment		Better than 40 dB	98 MHz, 60 dB (stereo) right channel input. Distortion factor must be less than 0.6%. Refer to Note 3.

Chart 1

NOTE 1. In the event that the distortion factors in Steps 8 and 9 are not less than 3%, re-adjust Front End Trimmer Condensers TCR and TCA to obtain a minimum average distortion factor at 88, 98, and 108 MHz (same distortion factor at all three points).

NOTE 2. PLL IC Free Running Frequency must be an exact 19.00 kHz.

NOTE 3. If the distortion factor is not less than 0.6%, turn IF Coil in Step 1 within 1/2 turn and adjust.

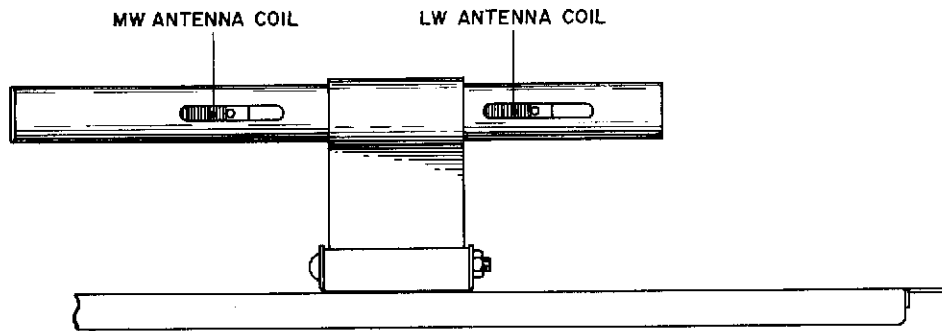

Fig. 11 Bar Antenna

2. LW SECTION ADJUSTMENT (Refer to Figs. 10 and 11)

Step	Adjustment Item	Adjustment Point	Result	Remarks
1	Low Range Frequency Coverage Adjustment	T2 (PNK) (Multi-Function P.C Board AA-5159A)	Error; Within 2%	Depress LW Selector. 160 kHz, optional input.
2	Low Range Sensitivity Adjustment	Bar Antenna LW coil T4 (YLW. BLK) T5 (WHT) (Multi-Function P.C Board AA-5159A)	Maximum Sensitivity	160 kHz, optional input.
3	High Range Frequency Coverage Adjustment	VC 2a (Multi-Function P.C Board AA-5159A)	Error; Within 2%	340 kHz, optional input.
4	High Range Sensitivity Adjustment	VC 1a (Multi-Function P.C Board AA-5159A)	Maximum Sensitivity	340 kHz, optional input.
5	Frequency Coverage and Sensitivity Adjustment			Repeat Steps 1 through 4 several times.

Chart 2

### 3. MW SECTION ADJUSTMENT (Refer to Figs. 10 and 11)

Step	Adjustment Item	Adjustment Point	Result	Remarks
1	Low Range Frequency Coverage Adjustment	T3 (RED) (Multi-Function P.C Board AA-5159A)	Error: With 2%	Depress MW Selector. 520 kHz, optional input.
2	Low Range Sensitivity Adjustment	Bar Antenna MW coil	Maximum Sensitivity	520 kHz, optional input.
3	High Range Frequency Coverage Adjustment	VC 2b (Multi-Function P.C Board AA-5159A)	Error: Within 2%	1,400 kHz, optional input.
4	High Range Sensitivity Adjustment	VC 1b (Multi-Function P.C Board AA-5159A)	Maximum Sensitivity	1,400 kHz, optional input.
5	Frequency Coverage and Sensitivity Adjustment			Repeat Steps 1 through 4 several times.

Chart 3

## VII. MAIN AMP ADJUSTMENT

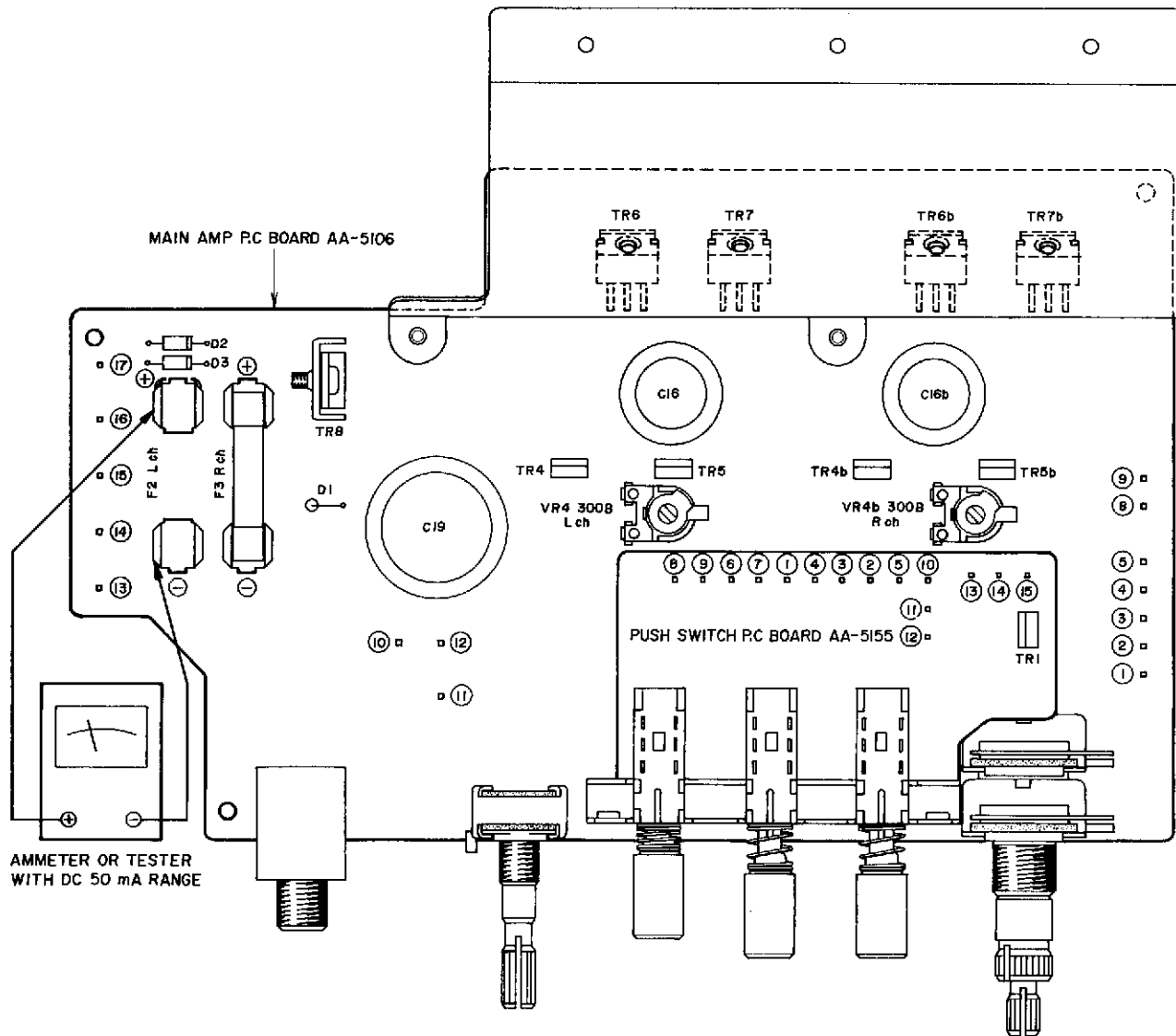

Fig. 12 Main Amp P.C Board AA-5106

### Idling Current Adjustment (Refer to Fig. 12)

1. Remove Power Fuses F2 2A (left channel) and F3 2A (right channel) and connect an ammeter to these terminals.
2. At non-signal input, adjust Semi-fixed Resistors VR4 300B (left channel) and VR4b 300B (right channel) to obtain a 20 mA idling current.



**RTV servis Horvat**

Kešinci, 31402 Semeljci

Tel : 031-856-637

Tel / fax : 031-856-139

Mob : 098-788-319

rtv-servis-horvat@os.tel.hr

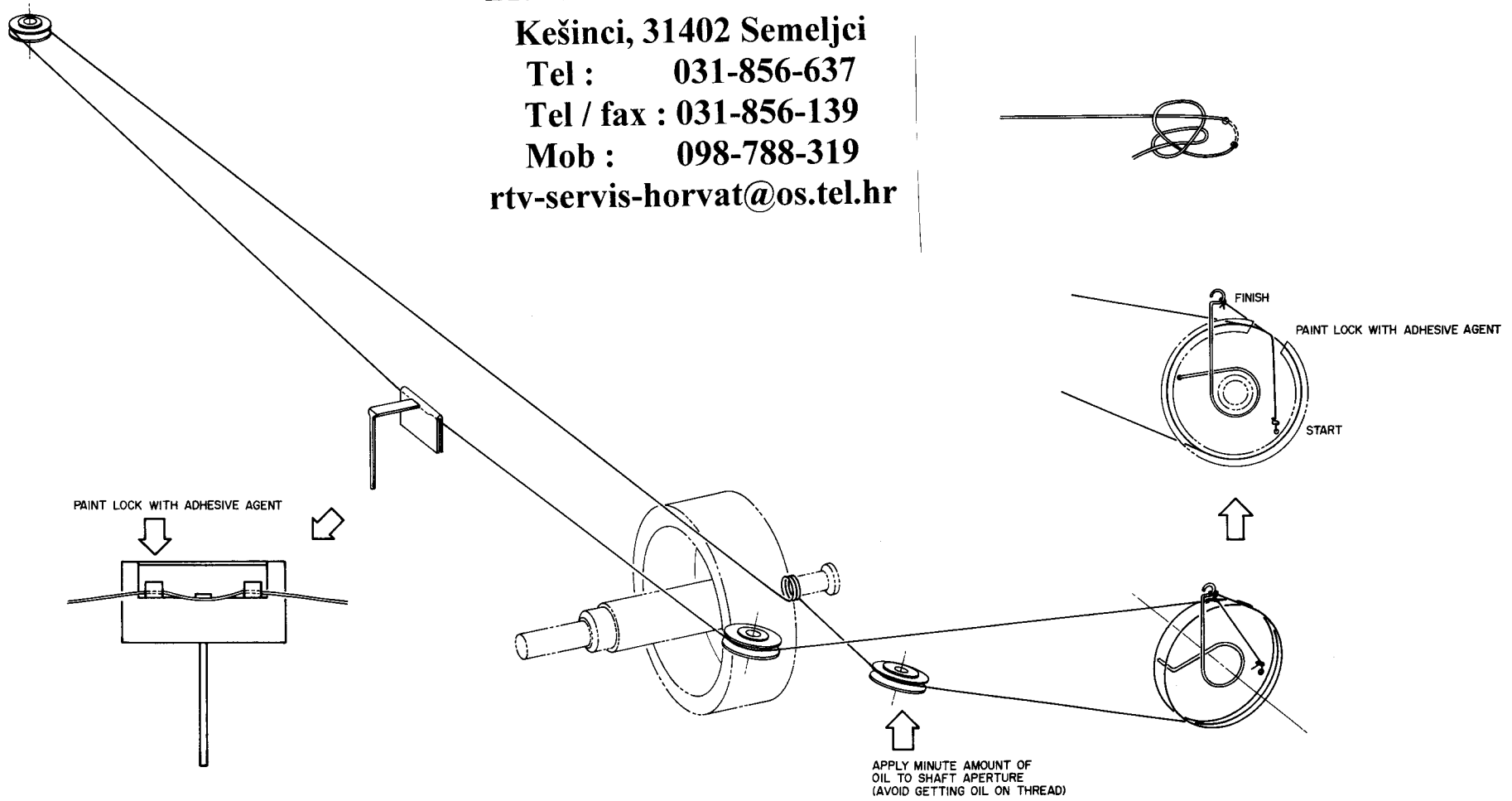

Fig. 13 Tuning Cord Threading

# IX. CLASSIFICATION OF VARIOUS P.C BOARD

---

## 1. RELATION OF P.C BOARD TITLE AND IDENTIFICATION NUMBER

P.C Board	Number of P.C Board
MFC P.C Board	AA-5159A
Main Amp P.C Board	AA-5106
Touch Switch P.C Board	AA-5158
Volume P.C Board	AA-5157
IC P.C Board	AA-5156
Push Switch P.C Board	AA-5155
LED P.C Board	AA-5159C

Chart 4

## 2. COMPOSITION OF VARIOUS P.C BOARD

### 1) MFC P.C BOARD AA-5159A & JUMPER P.C BOARD AA-5159B

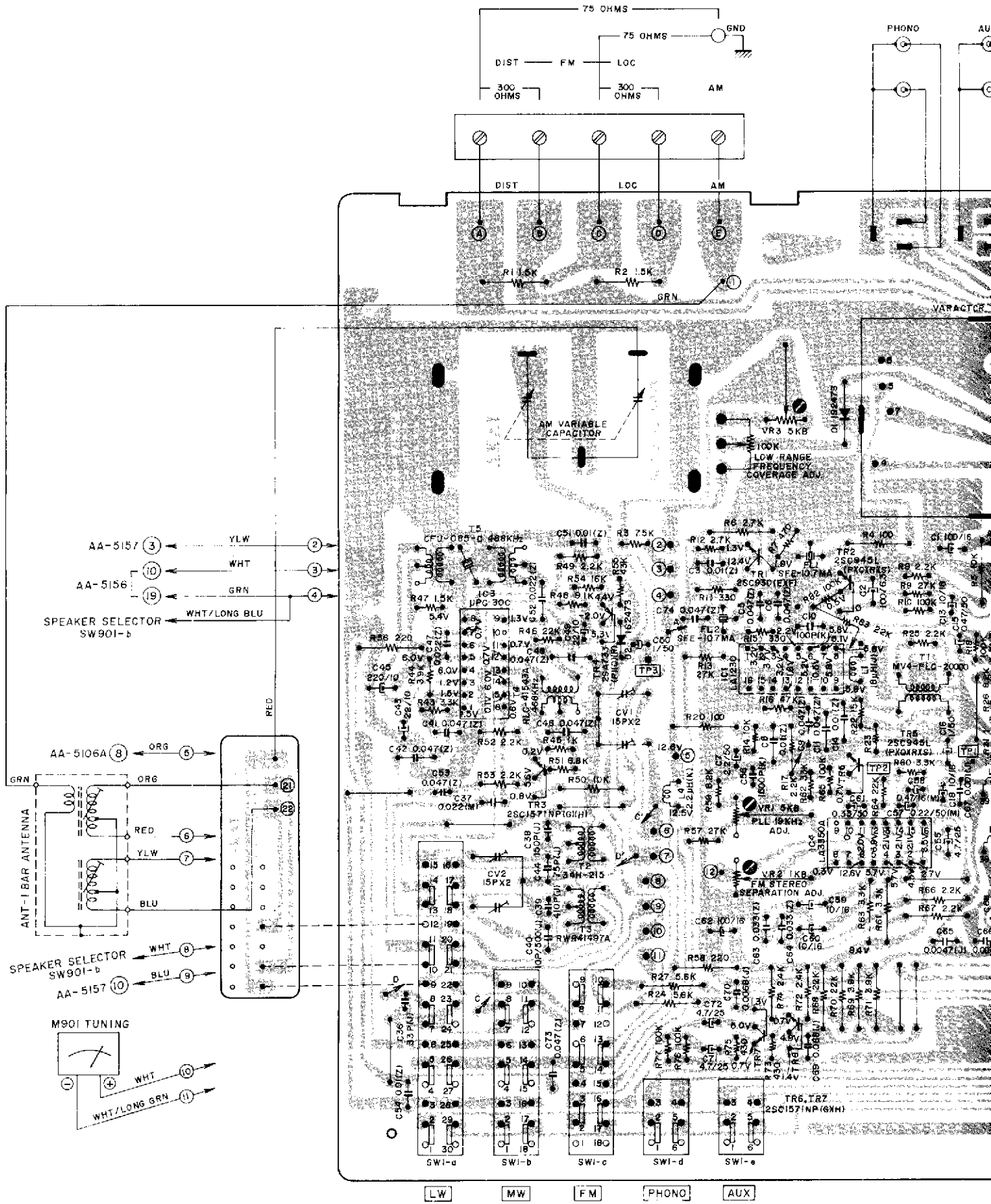

BOARD  
BOARD AA-5159B

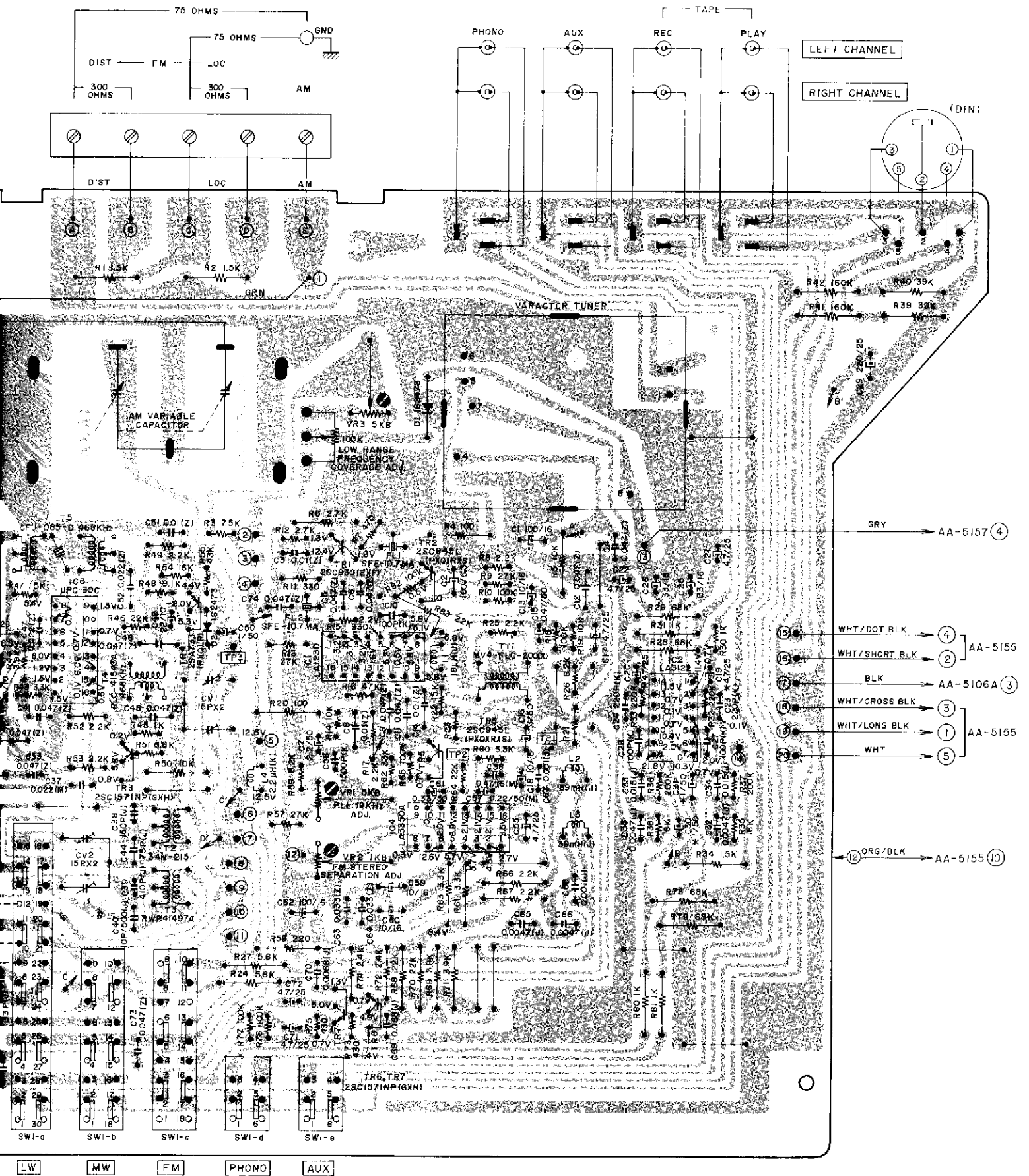

## 2) MAIN AMP P.C BOARD AA-5106

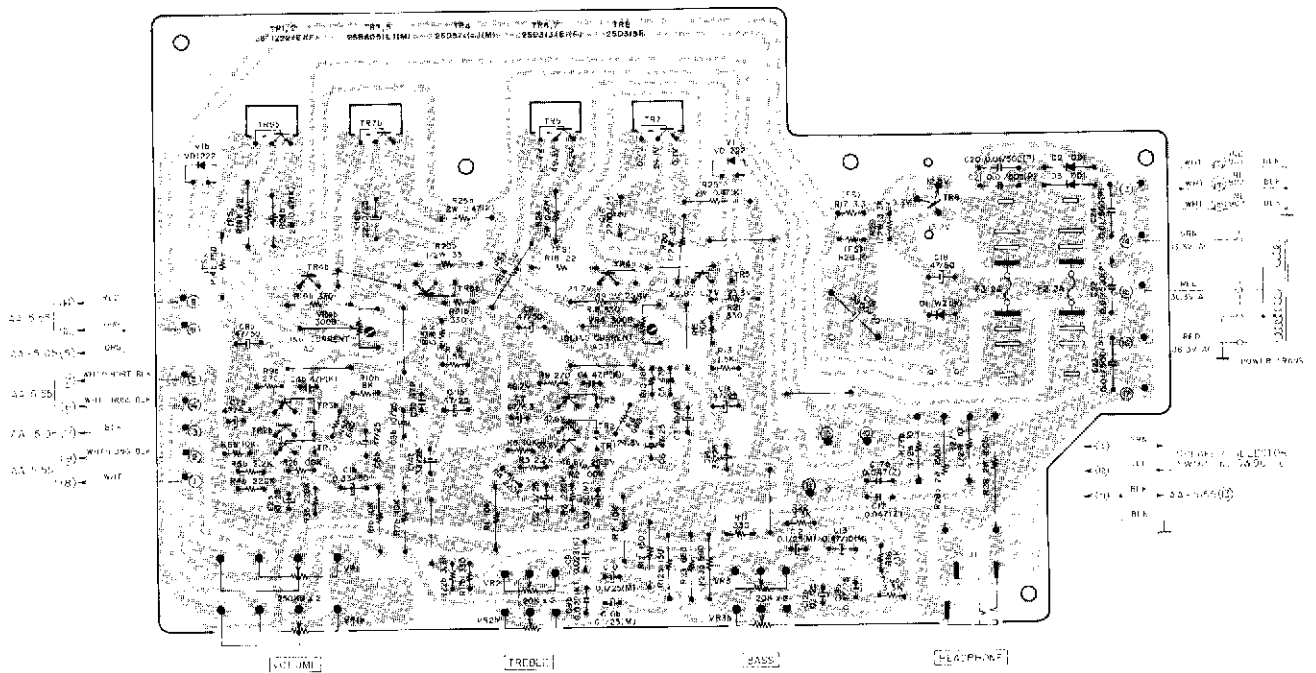

## 3) TOUCH SWITCH P.C BOARD AA-5158

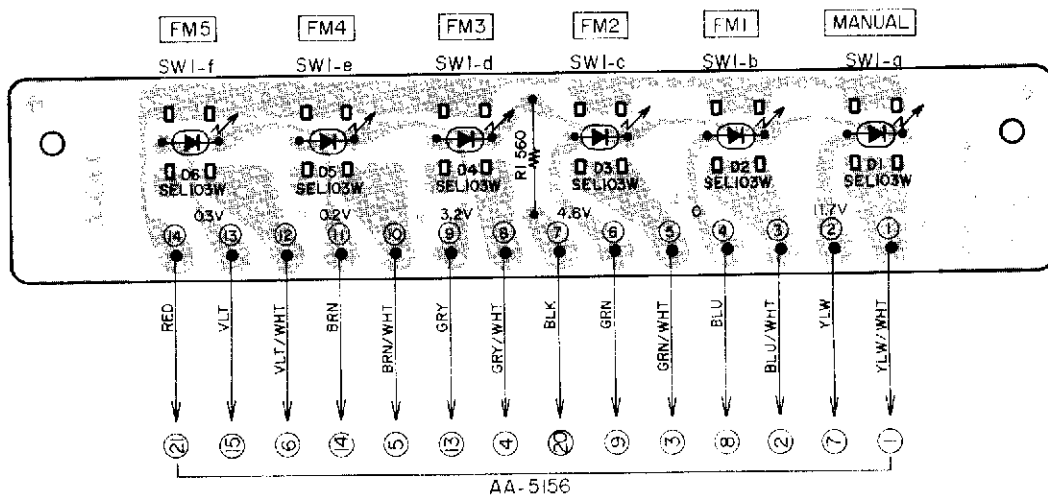

4) VOLUME P.C BOARD AA-5157

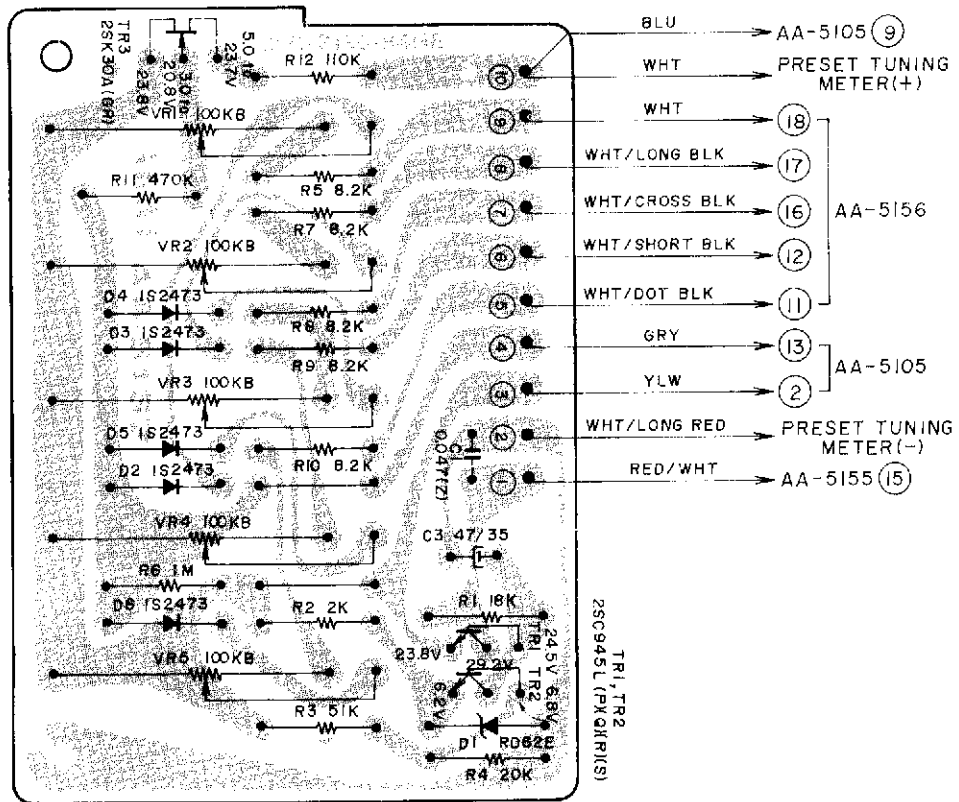

5) IC P.C BOARD AA-5156

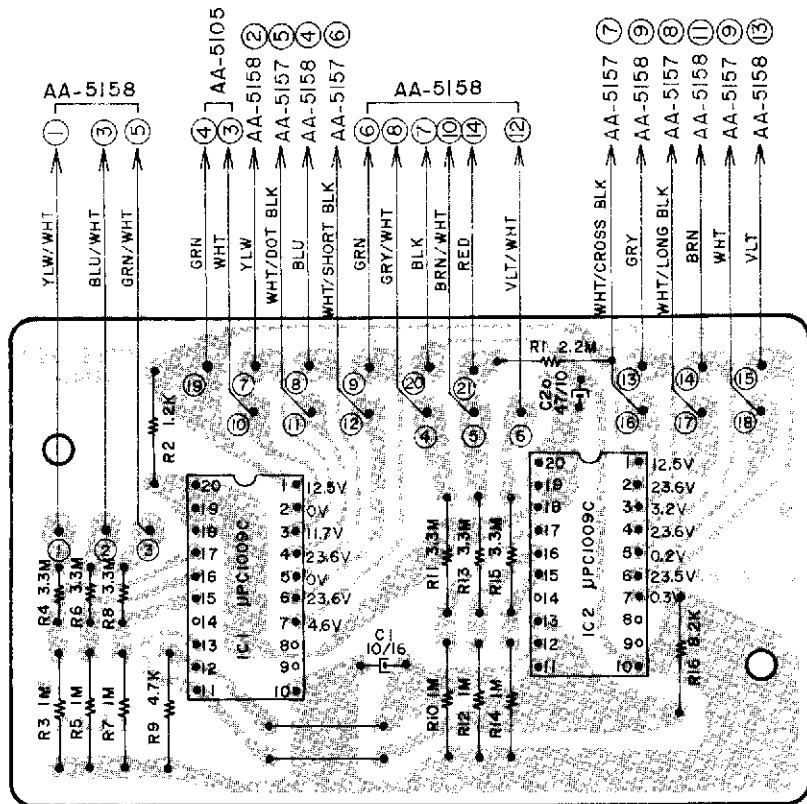

6) PUSH SWITCH P.C BOARD AA-5155 & LED P.C BOARD AA-5159C

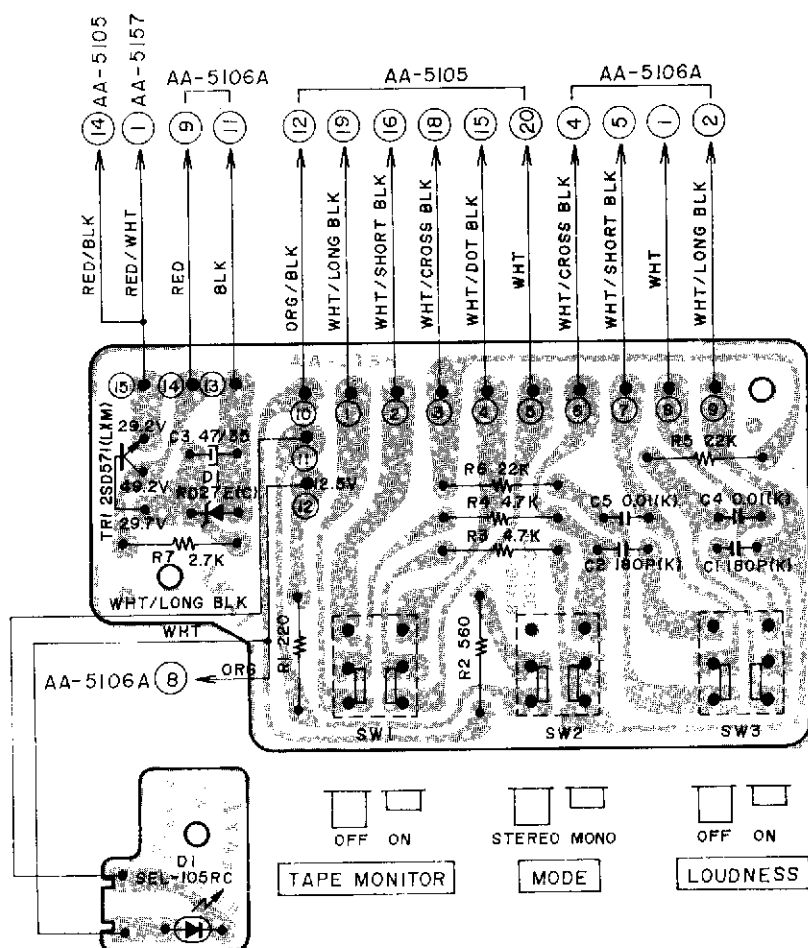

***RTV servis Horvat***

Kešinci, 31402 Semeljci

Tel : 031-856-637

Tel / fax : 031-856-139

Mob : 098-788-319

rtv-servis-horvat@os.tel.hr

## HOW TO USE THIS PARTS LIST

1. This parts list is compiled by various individual blocks based on assembly process.
2. When ordering parts, please describe parts number, serial number, and model number in detail.
3. How to read list.

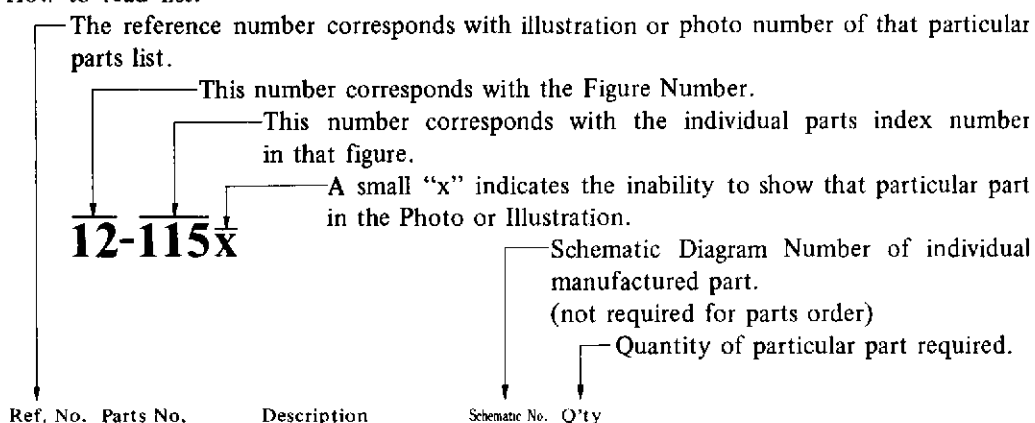

Ref. No.	Parts No.	Description	Schematic No.	Q'ty
<b>FLYWHEEL BLOCK #13</b>				
12-115x	800425	Flywheel Block Assy. Comp.	RDG #13	1
12-116	244506	Flywheel Only	RD-233	1
12-117x	244754	Felt, Flywheel	RD-275	1
12-118	251324	Main Metal Case	RD-236	1
12-119	253080	Main Metal	RD-237	1

4. The symbol numbers shown on the P.C. Board list can be matched with the Composite Views of components of the Schematic Diagram or Service Manual.
5. Please utilize separate "Common List for Service Parts" for Resistor parts orders.
6. The shape of the parts and parts name, etc. can be confirmed by comparing them with the parts shown on the Electrical Parts Table of P.C. Board.
7. Both the kind of part and installation position can be determined by the Parts Number. To determine where a parts number is listed, utilize Parts Index at end of Parts List.  
It is necessary first of all to find the Parts Number. This can be accomplished by using the Reference Number listed at right of parts number in the Parts Index. (meaning of ref. no. outlined in Item 3 above).
8. Utilize separate "Price List for Parts" to determine unit price. The most simple method of finding parts Price is to utilize the reference number.

- CAUTION:**
1. When placing an order for parts, be sure to list the parts no. model no., and description. There are instances in which if any of this information is omitted, parts cannot be shipped or the wrong parts will be delivered.
  2. Please be careful not to make a mistake in the parts no. If the parts no. is in error, a part different from the one ordered may be delivered.



## 1. RECOMMENDED SPARE PARTS LIST

Because, if the parts listed below are on hand, almost any repair can be accomplished, we suggest that you stock these Recommended Spare Parts Items.

Parts No.	Parts Nomenclature	Note
BA235225	Main Amp P.C Board Comp. AA-5106A	
BA235236	Main Amp P.C Board Comp. AA-5106A	CEE
BA235258	Multi Function P.C Board Comp. AA-5159A	
BA235247	LED P.C Board Comp. AA-5106B	
BA235146	Push SW. P.C Board Comp. AA-5155	
BA235157	Vol. P.C Board Comp. AA-5157	
BA235203	IC P.C Board Comp. AA-5156	
BA235170	Touch SW. P.C Board Comp. AA-5158	
BC699783	Cabinet AA-5123	Same as AA-1010
BD235078	Front Panel Block Comp.	
BT699805	Power Trans. AA-1010T-5	Same as AA-1010
BT215133	Power Trans. AA-1010T-7	Same as AA-1010 CEE
BT633025	LW OSC. Trans. 34H-215	
EC240298	Vari. Con C626W	
EC675742	Trimmer Condenser CTY-21D 15PF	
ED240366	Zener Diode RD27E(C)	
ED229803	Zener Diode RD6.2E	
ED653624	Luminous Diode SEL-103W	
EE240041	Bar Antenna (MW/LW)	
EI229443	IC $\mu$ PC1009C	
EI669047	IC LA1230Z	Same as AA-1010
EI697871	IC LA3122	"
EI650362	IC $\mu$ PC30C	"
EI650597	IC LA3350A	"
EJ655683	4P Speaker Jack	"
EL650193	Lamp (Cord Type) 14V 100 mA (650m/mx2)	"
EM655727	Tuning Meter KL-218D-94	
EM240311	Pre-set Tuning Meter	
EO650608	Discriminator Coil MV4-FLC-20000	Same as AA-1010

Parts No.	Parts Nomenclature	Note
EO645838	OSC Coil RWR41497A	
EO650373	AM-IF Trans. RLC-41543A 468 kHz	Same as AA-1010
EO650384	AM-IF Trans. CFU-085-D 468 kHz	
ES240355	Rotary SW. SR26N 1-3-5 30 KC	
ES240287	Rotary SW. SR26N 30 KC	
ES240096	Push SW. 3FT-0001FF2120	
ES240276	Push SW. 5FT-0001DF3620	
EV240434	Double axial 2 throw Vol (FR) DJ80D 250 kBx2	
EV240445	Single axial 2 throw Vol. GM70R 20 kCx2	
EV229915	Pre-set Vol. (w/knob) LFQDR504 100 kB	
EV499364	Semi-fixed Vol. V10K8-4-2 5 kB	Same as AA-1010
EV484863	Semi-fixed Vol. V10K8-4-2 1 kB	"
EZ655187	5P Antenna Terminal Plate	"
SB607138	Push Knob C A5-5022	
SK646817	Single Knob AA-5250	
SK644670	Double Knob (Upper) AA-5355	Same as AA-1010
SK645208	Double Knob (Lower) AA-5353	"
SK646828	Tuning Knob (Small) AA-5252	"
SZ645243	Circular Foot A CA-6014	"
TA240300	Varactor Tuner VFT-22MH-21	

**2. MULTI FUNCTION P.C BOARD  
(AA-5159A) BLOCK  
(JUMPER P.C BOARD (AA-5159B) BLOCK)**

Symbol No.	Parts No.	Description	Schematic No.	Q'ty
2-1	BA235258	Multi Function P.C Board Comp. (AA-5159A)		1
2-IC1	EI669047	IC LA-2130Z	45-8-176	1
2-IC2	EI697871	IC LA-3122	45-8-185	1
2-IC3	EI650362	IC $\mu$ PC30C	45-8-151	1
2-IC4	EI650597	IC LA-3350S	45-8-153	1
2-TR1	ET618873	Transistor 2SC930(E)(F)	45-1-185	1
2-TR2	ET515733	Transistor 2SC945(P)(Q)(R)(S)	45-1-85	1
2-TR3	ET223446	Transistor 2SC1571NP (G)(H)	45-1-238	1
2-TR4	ET539122	Transistor 2SA733(P)(Q)(R)	45-1-124	1
2-TR5	ET515733	Transistor 2SC945(P)(Q)(R)(S)	45-1-85	1
2-TR6,7	ET223446	Transistor 2SC1571NP(G)(H)	45-1-238	2
2-D1,2	ED624903	Silicon Diode 1S2473	45-3-28	2
2-FL1,2	ER650430	Ceramic Filter SFE-10.7 MA-8-Z	53-1-102	2
2-T1	EO650608	Discri Coil MV4-FLC-20000	23-1-243	1
2-T2	BT633025	LW OSC. Trans. 34H-215	23-1-235	1
2-T3	EO645838	OSC. Coil RWR41497A	23-4-35	1
2-T4	EO650373	AM-1F Trans. RLC-41543A 468 kHz	23-1-242	1
2-T5	EO650384	AM-1F Trans. CFU-085-D 468 kHz	23-1-241	1
2-L1	EO650610	Inductor 144LZ 18 $\mu$ H(J)	23-1-240	1
2-L2,3	EO650428	Inductor 146LY 39MH(J)	23-1-214	2
2-L4	EO539820	Peaking Coil 2.2 $\mu$ H(K)	23-1-187	1
2-VR1	EV499364	Semi-fixed/Vol. V10K8-4-2 5 kB	36-10-250	1
2-VR2	EV484863	Semi-fixed/Vol. V10K8-4-2 1 kB (Metalized Film)	36-10-250	1
2-VR3	EV499364	Semi-fixed/Vol. V10K8-4-2 5 kB	36-10-250	1
2-J1	EJ655334	8P Pin Jack	31-1-149	1
2-J2	EJ698051	Din Jack	31-1-158	1
2-VC1,2	EC675742	Trimmer/C. CTY-21D 15PF	24-2-35	2
2-SW1	ES240276	Push SW 5FT-0001DF3620	25-5-235	1
2-C39	EC658001	Styrol/C. 410PF(J) 50WV (Vert. Type)	24-11-3	1
2-C56	EC666483	Styrol/C. 1500PF(K) 50WV (Vert. Type)	24-11-11	1
2-C58	EC215065	Solid Aluminum/C. 0.47 $\mu$ F(M) 16WV	24-19-2	1
2-2	MZ656807	Jumper Wire, P.C Board 12.5mm	35-18-1	16
2-3	BA235271	Jumper P.C Board Comp. (AA-5159B)		1

**3. MAIN AMP P.C BOARD (AA-5106A) BLOCK**

Symbol No.	Parts No.	Description	Schematic No.	Q'ty
3-1	BA235225	Main Amp P.C Board Comp. (AA-5106A)		1
3-2	BA235236	Main Amp P.C Board Comp. (AA-5106A) (CEE)		1
3-TR1,2	ET459810	Transistor 2SC1222(E)(F)	45-1-110	4
3-TR3	ET655345	Transistor 2SB605(L)(M)	45-1-225	2
3-TR4	ET655356	Transistor 2SD571(L)(M)	45-1-218	2
3-TR5	ET655345	Transistor 2SB605(L)(M)	45-1-225	2
3-TR8	ET452531	Transistor 2SD313(E)(F)	45-1-105	1
3-D1	ED539976	Zener Diode WZ-130	45-6-67	1
3-D2,3	ED224548	Silicon Diode 10D2	45-2-14	2
3-V1	ED490511	Varistor VD1222	45-10-7	2
3-VR1	EV240434	Double/Vol. (FR.) DJ80D 250k $\times$ 2	36-3-75	1

Symbol No.	Parts No.	Description	Schematic No.	Q'ty
3-VR2,3	EV240445	Single axial 2 throw Vol. GM70R 20 k $\times$ 2	36-22-22	2
3-VR4	EV604484	Semi-fixed/Vol. V10K8-4-2 300 ohms(B)	36-10-250	2
3-J1	EJ698286	3P Jack	31-2-72	1
3-FR1	ER565828	Fuse/R. FRN70 1/4W 10 ohms (K) 700 mA	35-14-11	2
3-R24,25	ER552712	Metal Plate/R. MPC70F 2W 0.47 ohms (K)	35-16-38	4
3-R28	ER439132	Metal Oxide Film/R. 2W 150 ohms (K)	35-15-8	2
3-C10	EC654153	Tantalum/C. 0.1 $\mu$ F(M) 25WV (DTS Type)	24-15-8	2
3-C12	EC523282	Solid Aluminum/C. 0.1 $\mu$ F(M) 25WV (Vert. Type)	24-19-2	2
3-C13	EC538244	Solid Aluminum/C. 0.47 $\mu$ F(M) 10WV (Vert. Type)	24-19-2	2
3-3	MZ656807	Jumper Wire, P.C Board 12.5mm	35-18-1	10
3-4	EJ514822	Fuse Holder, P.C Board S-N5051	40-1-28	4
3-5	EJ592503	Fuse Clip, P.C Board H0426 (CEE)	40-1-37	4

**4. TOUCH SW. P.C BOARD (AA-5158) BLOCK**

Symbol No.	Parts No.	Description	Schematic No.	Q'ty
4-1	BABA235170	Touch SW. P.C Board Comp. (AA-5158)		1

**5. VOL. P.C BOARD (AA-5157) BLOCK**

Symbol No.	Parts No.	Description	Schematic No.	Q'ty
5-1	BA235157	Vol. P.C Board Comp. (AA-5157)		1
5-TR1,2	ET515733	Transistor 2SC945(P)(Q)(R)(S)	45-1-85	2
5-TR3	ET491051	FET 2SK30A(GR)	45-12-4	1
5-D1	ED229803	Zener Diode RD6.2E	45-6-74	1
5-D2to6	ED624903	Silicon Diode 1S2473	45-3-28	5
5-VR1to5	EV229915	Pre-set Vol. 1FQDR504 100 kB (w/knob)	36-37-1	5

**6. IC P.C BOARD (AA-5156) BLOCK**

Symbol No.	Parts No.	Description	Schematic No.	Q'ty
6-1	BA235203	IC P.C Board Comp. (AA-5156)		1
6-IC1,2	EI229443	IC $\mu$ PC1009C	45-8-202	2

**7. PUSH SW. P.C BOARD (AA-5155) BLOCK  
(LED P.C BOARD (AA-5159C) BLOCK)**

Symbol No.	Parts No.	Description	Schematic No.	Q'ty
7-1	BA235146	Push SW. P.C Board Comp (AA-5155)		1
7-TR1	ET655356	Transistor 2SD571(L)(M)	45-1-218	1
7-D1	ED240366	Zener Diode RD27E(C)	45-6-72	1
7-SW1	ES240096	Push SW. 3FT-0001FF2120	25-5-234	1
7-2	EA241154	LED P.C Board	AA-5159C	1
7-D1	ED694091	LED SEL-10SRC	45-15-12	1
7-3	TA241064	Lamp Base A	AA-5145	1
7-4	ZS422076	Screw, pan head 3 $\times$ 5		1

8. ILLUSTRATION OF ASSEMBLY BLOCK

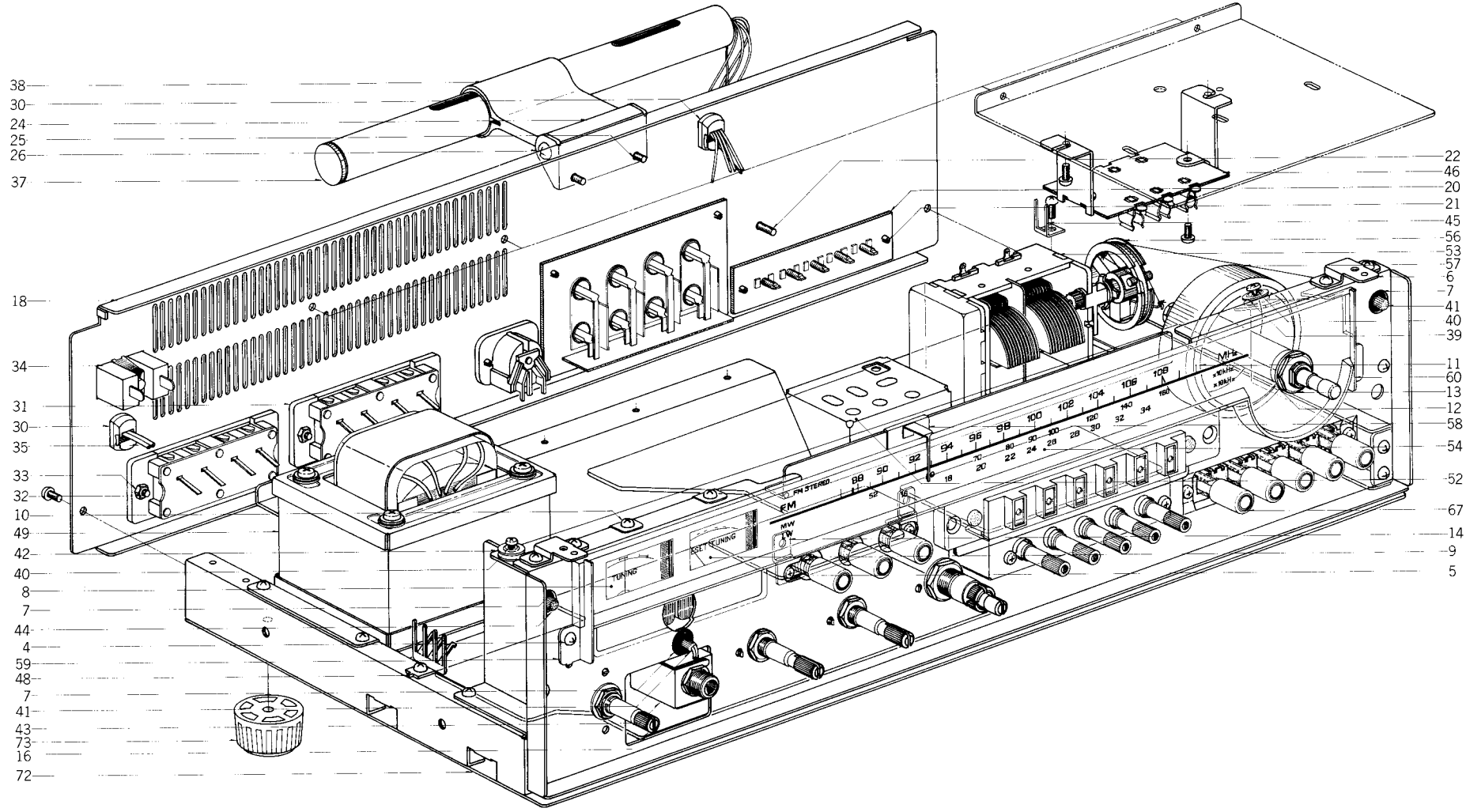

## 8. ASSEMBLY BLOCK

Ref. No.	Parts No.	Description	Schematic No.	Q'ty	Ref. No.	Parts No.	Description	Schematic No.	Q'ty
<b>HEAT-SINK BLOCK</b>									
8-1x	ZW632226	Insulator Washer Bush M	45-16-27	4	8-51x	EJ254957	Lug Plate KP1L	33-3-2	1
8-2x	ZS379350	Screw, pan head 3x6		6	8-52	EC240298	Variable/C. C626W	24-2-40	1
8-3x	ET452531	Transistor 2SD313(E)(F)	45-1-105	4	8-53	TA240300	Varactor Tuner VFT-22MH-21	57-2-41	1
8-4	ZS325495	Tapping Screw #2 3x6 (BR)		45	8-54	TA241007	Scale Plate A	AA-5125	1
8-5	ZS422076	Screw, pan head 3x5		17	8-55x	ZG241086	Dial Spring	AA-5147	1
<b>FRONT CHASSIS BLOCK</b>									
8-6	TA646571	Panel Support	AA-5218	2	8-56	MT240388	Dial Wheel	2-15-14	1
8-7	MB650147	Rubber Bushing No. No. 6552	3-13-44	3	8-57	TA207347	Thread D0.5 1.6m		1
8-8	EM655727	Tuning Meter KL-218D-94	46-1-110	1	8-58	TA646795	Pointer	AA-5242	1
8-9	EM240311	Pre-set Tuning Meter	46-1-143	1	8-59	TA697004	Scale Plate Retainer A	AA-5118	1
8-10	ZS455207	Tapping Screw #2 3x5 (BR)		5	8-60	TA697015	Scale Plate Retainer B	AA-5118	1
8-11	MI698310	Tuning Wheel	13-2-4	1	8-61x	ZW330412	Adjust. Washer (U) D4x13x0.13t		2
8-12	ZW610503	Washer D11	36-13-2	2	8-62x	ZW330423	Adjust. Washer (U) D4x13x0.25t		2
8-13	ZW610492	Nut M11	36-13-3	2	8-63x	ZW330434	Adjust. Washer (U) D4x13x0.5t		2
8-14	TA241121	Push SW. Mt. Plate	AA-5154	1	8-64x	ZW330445	Adjust. Washer (U) D4x13x0.8t		2
8-15x	ZS421806	Screw, pan head 3x8		2	8-65x	ZW330456	Adjust. Washer (U) D4x13x1t		2
8-16	ES240355	Rotary SW. SR26N 1-3-5 30kC	25-6-102	1	8-66x	ZW439547	Adjust. Washer (U) D4x13x1.5t		2
8-17x	ES240287	Rotary SW. SR26N 30 kC (CEE)	25-6-103	1	8-67	SK634410	Push Button Knob J	91-5051	8
<b>REAR PANEL BLOCK</b>									
8-18	SP240985	Rear Panel 6	AA-5112	1	8-68x	EF563703	Fuse 2A 250V	39-1-50	4
8-19x	SP240996	Rear Panel 7 (CFE)	AA-5112	1	8-69x	EF258344	Fuse (SEMKO T Type) 800 mA T (CEE)	39-1-53	1
8-20	EZ655187	5P Antenna Terminal Plate	32-1-69	1	8-70x	EF601301	Fuse (SEMKO T Type) 2AT (CEE)	39-1-53	1
8-21	ZW698308	Nylon Rivet (FNPR) 3x5.5 Black	27-54	5	8-71x	EF623103	Fuse (SEMKO T Type) 1AT (CEE)	39-1-53	2
8-22	SK652397	Knob 0512-2	34-1-4	1	8-72	SP697116	Bottom Plate	AA-5122	1
8-23x	ZW652408	Washer (SPC) D3.2x10x0.5t		1	8-73	SZ645243	Circular Foot A	CA-6014	4
8-24	TA530910	Antenna Channel	91-5029	1	8-74x	EA642701	Repeater P.C Board (CEE)	33-2-52	1
8-25	ZS447761	Tapping Screw #2 3x6 (BR) (Black)		8	8-75x	TA697026	Repeater Terminal Plate Parts (CEE)	AA-5111	1
8-26	ZS552600	Screw, pan head 4x50		1					
8-27x	ZW273914	Spring Washer M4		6					
8-28x	ZW420682	Washer (Nylon) D4.2x9x0.5t		2					
8-29x	ZW413188	Nut M4, #1		5					
8-30	EZ631945	Strain Relief SR-4N-4	2-7-49	2					
8-31	EJ655683	4P Speaker Jack	32-1-68	2					
8-32	ZS421740	Screw, pan head 3x8		4					
8-33	ZW273756	Nut M3, #1		4					
8-34	EJ650261	AC Socket U/L S-16432	31-1-147	1					
8-35	FW540123	AC Cord (CUL) 2.5M	26-3-20	1					
8-36x	EW516600	AC Cord (CEE) VM-0065	26-3-28	1					
8-37	EE240041	Bar Antenna 2 Band	55-1-36	1					
8-38	TA625847	Antenna Holder	2-7-46	1					
<b>ASSEMBLY BLOCK</b>									
8-39	MR530651	Roller A	91-5008	2					
8-40	ZS530673	Roller Screw A	91-5010	3					
8-41	EL650193	Lamp (Cord Type) 14V 100 mA (650m/mx2)	28-2-47	3					
8-42	MR530662	Roller B	91-5009	1					
8-43	TA697050	Headphone Jack Parts	AA-5109	1					
8-44	ZW270191	E Jack Nut		1					
8-45	EJ539447	Earth Terminal 2P T4460	32-1-32	1					
8-46	EZ652410	Fuse Holder 3P Table	40-1-68	1					
8-47x	EJ215122	2P Fuse Hodler (Small) (CEE)	40-1-99	1					
8-48	EJ551035	Wrapping Terminal, 4P T-5251	32-1-36	1					
8-49	BT699805	Power Trans. AA-1010T-5	38-4-418	1					
8-50x	BT215133	Power Trans. AA-1010T-7 (CEE)	38-4-420	1					

When ordering parts, Please describe Parts Number, Description, and Model Number in detail.

## 9. PHOTO OF FINAL ASSEMBLY BLOCK

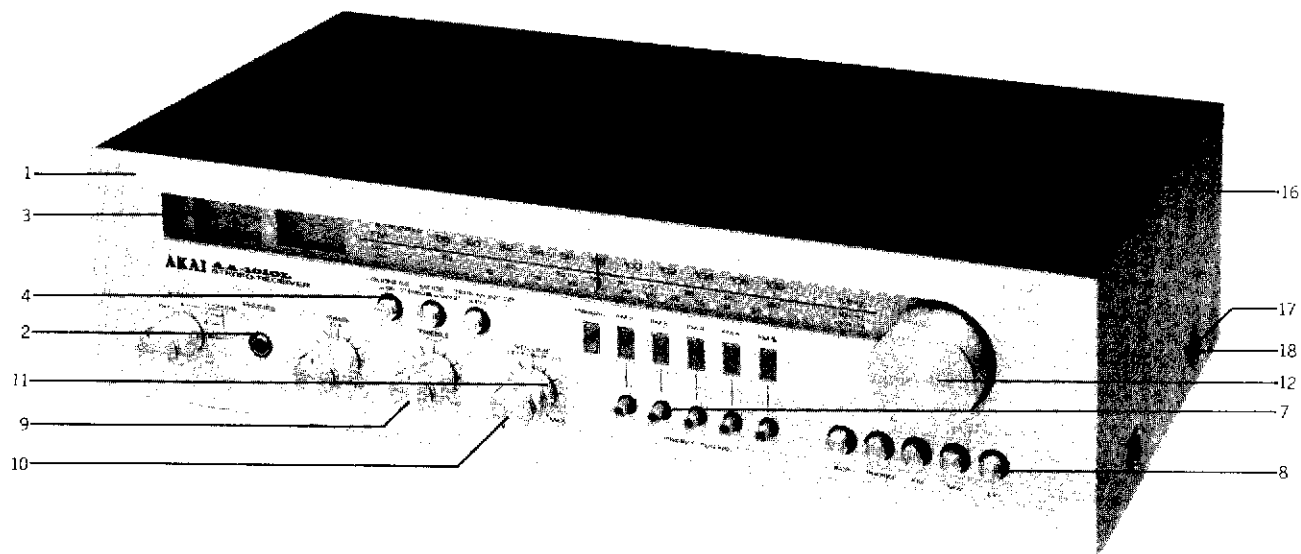

### 9. FINAL ASSEMBLY BLOCK

Ref. No.	Parts No.	Description	Schematic No.	Q'ty
<b>FRONT PANEL BLOCK</b>				
9-1	BD235078	Front Panel Block Comp.		1
9-2	ZW526577	Collar B, Jack	MC-5006	1
9-3	SP645715	Front Plate	AA-5245	1
9-4	SE613888	Button Escutcheon A	CW-6021	3
9-5	SE699761	Light Mask	AA-5119	2
9-6x	SE675606	Button Escutcheon	CB-6004	1
9-7	SE631585	Button Escutcheon D	CG-6814	5
<b>ASSEMBLY BLOCK</b>				
9-8	SK634410	Push Button Knob J	91-5051	8
9-9	SK646817	Single Knob	AA-5250	3
9-10	SK644670	Double Knob (Upper)	AA5355	1
9-11	SK645208	Double Knob (Lower)	AA-5353	1
9-12	SK646828	Tuning Knob (Small)	AA-5252	1
9-13x	ZS203343	Set Screw, hexagon socket 3x18 WP		1
9-14x	ZS447840	Tapping Screw #2 3x8 (BR)		1
9-15x	ZS565942	Tapping Screw #2 4x8 (PAN)		4
9-16	BC699783	Cabinet	AA-5123	1
9-17	ZW548010	Spot Facing Washer	MU-6028	4
9-18	ZS510344	Screw, binding head 4x12		4

When ordering parts, Please describe Parts Number, Description, and Model Number in detail.

## 10. LIST OF INTERCHANGEABLE SEMICONDUCTORS

As far as service is concerned, in case the original parts cannot be obtained, the interchangeable parts listed below can be substituted.

Original Parts			Interchangeable Parts	
Description	Parts No.	Utilizing P.C Board	Description	Parts No.
2SA733(P)(Q)(R)	ET539122	AA-5159A	2SA628(D)(E)(F) 2SA564(Q)(R)	ET515700 ET538154
2SB605(L)(M)	ET655345	AA-5106A	2SA720(Q)(R)	ET554736
2SC930(E)(F)	ET618873	AA-5159A	2SC454(B)(C)	ET591366
2SC945L (P)(Q)(R)(S)	ET515733	AA-5159A AA-5157	2SC536(E)(F)(G)(H) 2SC711(E)	ET246846 ET380834
2SC1222(E)(F)	ET459810	AA-5106A	2SC1313(G)(H)	ET604124
2SC1571NP(G)(H)	ET223446	AA-5159A	2SC1222(E)(F)	ET459810
2SD313(E)(F)	ET452531	AA-5106A	2SD234(Y)(O) 2SC1061(B)(C)	ET393568 ET357603
2SD571(L)(M)	ET655356	AA-5106A AA-5155	2SD313(E)(F)	ET452531
2SK30A(GR)	ET491051	AA-5157	2SK30A(D)	ET645917
1S2473	ED624903	AA-5195A AA-5157	1S1588 1S2473VE	ED557447 ED560913
IOD2	ED224548	AA-5106A	GP15D 1N4003	ED219903 ED570295

## INDEX

Parts No.	Ref. No. & Symbol No.	Parts No.	Ref. No. & Symbol No.	Parts No.	Ref. No. & Symbol No.	Parts No.	Ref. No. & Symbol No.	Parts No.	Ref. No. & Symbol No.
BA235146	7-1	EI697871	2-IC2	ET618873	2-TR1	TA207347	8-57	ZW548010	9-17
BA235157	5-1	FJ215122	8-47x	ET655345	3-TR3	TA240300	8-53	ZW610492	8-13
BA235170	4-1	EJ254957	8-51x	ET655345	3-TR5	TA241007	8-54	ZW610503	8-12
BA235203	6-1	EJ514822	3-4	ET655356	3-TR4	TA241064	7-3	ZW632226	8-1x
BA235225	3-1	EJ539447	8-45	ET655356	7-TR1	TA241121	8-14	ZW652408	8-23x
BA235236	3-2	EJ551035	8-48	EV229915	5-VR1to5	TA530910	8-24	ZW698308	8-21
BA235258	2-1	EJ592503	3-5	EV240434	3-VR1	TA625847	8-38		
BA235271	2-3	EJ650261	8-34	EV240445	2-VR2,3	TA646571	8-6		
BC699783	9-16	EJ655334	2-J1	FV484863	2-VR2	TA646795	8-58		
BD235078	9-1	EJ655683	8-31	EV499364	2-VR1	TA697004	8-59		
BT215133	8-50x	EJ698051	2-J2	EV499364	2-VR3	TA697015	8-60		
BT633025	2-T2	EJ698286	3-J1	EV604484	3-VR4	TA697026	8-75x		
BT699805	8-49	EL650193	8-41	EW516600	8-36x	TA697050	8-43		
EA241154	7-2	EM240311	8-9	EW540123	8-35	TG241086	8-55x		
EA642701	8-74x	EM655727	8-8	EZ631945	8-30	ZS203343	9-13x		
EC215065	2-C58	EO539820	2-L4	EZ652410	8-46	ZS325495	8-4		
EC240298	8-52	EO645838	2-T3	FZ655187	8-20	ZS379350	8-2x		
EC523282	3-C12	EO650373	2-T4	MB650147	8-7	ZS421740	8-32		
EC538244	3-C13	EO650384	2-T5	M1698310	8-11	ZS421806	8-15x		
EC654153	3-C10	EO650428	2-L2,3	MR530651	8-39	ZS422076	7-4		
EC658001	2-C39	EO650608	2-T1	MR530662	8-42	ZS422076	8-5		
EC666483	2-C56	EO650610	2-L1	MT240388	8-56	ZS447761	8-25		
EC675742	2-VC1,2	ER439132	3-R28	MZ656807	2-2	ZS447840	9-14x		
ED224548	3-D2,3	FR552712	3-R24,25	MZ656807	3-3	ZS455207	8-10		
ED229803	5-D1	ER565828	3-PR1	SE613888	9-4	ZS510344	9-18		
ED240366	7-D1	ER650430	2-FL1,2	SE631585	9-7	ZSS30673	8-40		
ED490511	3-V1	ES240096	7-SW1	SE675606	9-6x	ZSS52600	8-26		
ED539976	3-D1	ES240276	2-SW1	SR699761	9-5	ZSS65942	9-15x		
ED624903	2-D1,2	ES240287	8-17x	SK634410	8-67	ZW270191	8-44		
ED624903	5-12to6	ES240355	8-16	SK634410	9-8	ZW273756	8-33		
ED694091	7-D1	ET223446	2-TR3	SK644670	9-10	ZW273914	8-27x		
EF240041	8-37	ET223446	2-TR6,7	SK645208	9-11	ZW330412	8-61x		
EF258344	8-69x	ET452531	3-TR8	SK646817	9-9	ZW330423	8-62x		
EF563703	8-68x	ET452531	8-3x	SK646828	9-12	ZW330434	8-63x		
EF601301	8-70x	ET459810	3-TR1,2	SK652397	8-22	ZW330445	8-64x		
EF623103	8-71x	ET491051	5-TR3	SP240985	8-18	ZW330456	8-65x		
EI229443	6-IC1,2	ET515733	2-TR2	SP240996	8-19x	ZW413188	8-29x		
EI650362	2-IC3	ET515733	2-TR5	SP645715	9-3	ZW420682	8-28x		
EI650597	2-IC4	ET515733	5-TR1,2	SP697116	8-72	ZW439547	8-66x		
EI669047	2-IC1	ETS39122	2-TR4	SZ645243	8-73	ZW526577	9-2		

### SECTION 3

## SCHEMATIC DIAGRAM

1. AA-1010L CONNECTION DIAGRAM
2. AA-1010L MFC SCHEMATIC DIAGRAM
3. AA-1010L MAIN AMP.  
SCHEMATIC DIAGRAM
4. AA-1010L VARACTOR TUNER  
SCHEMATIC DIAGRAM



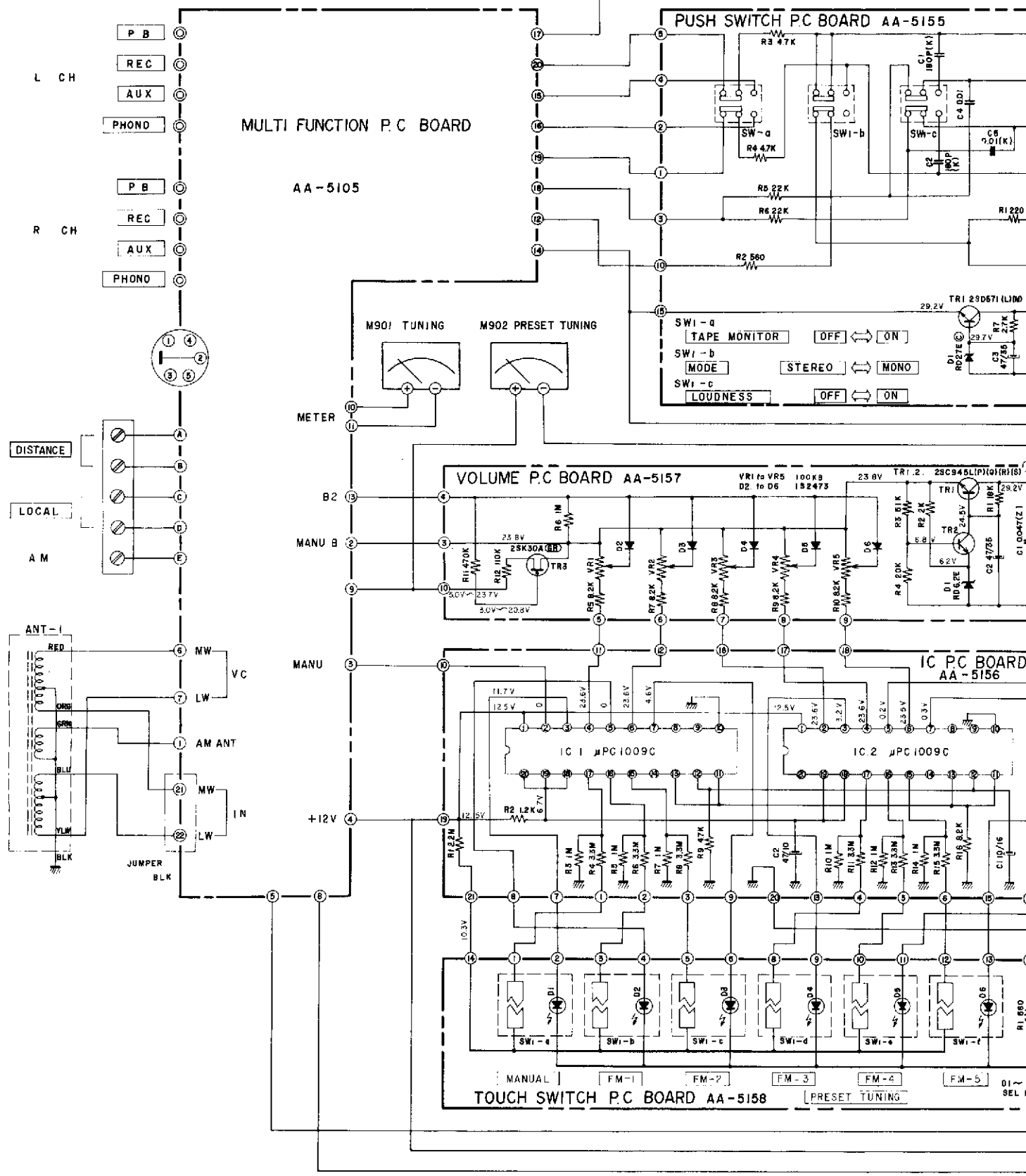

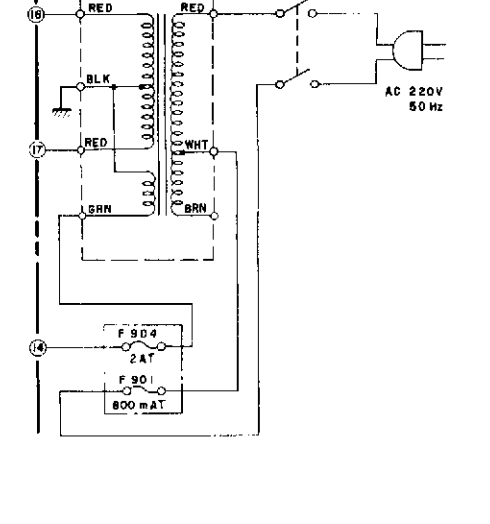
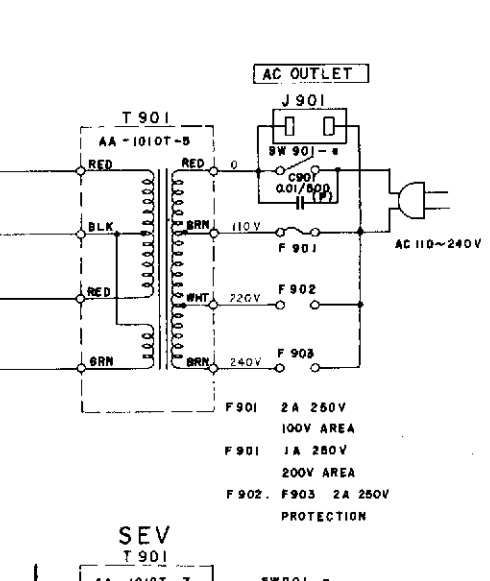
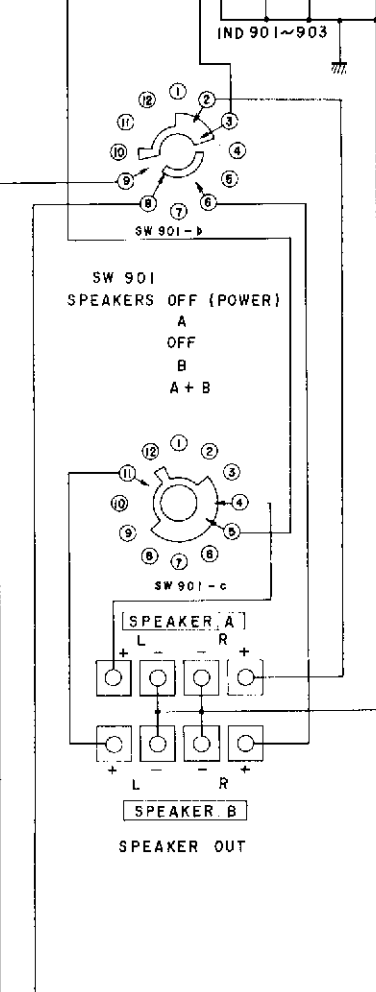
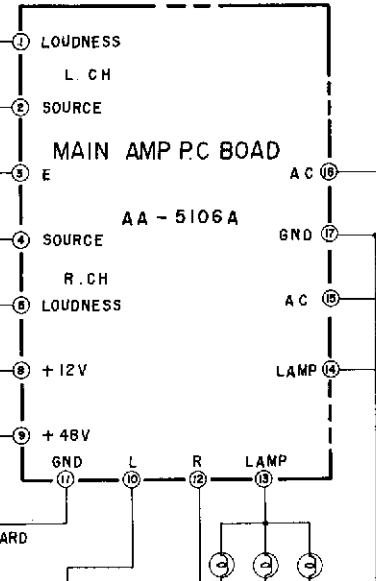
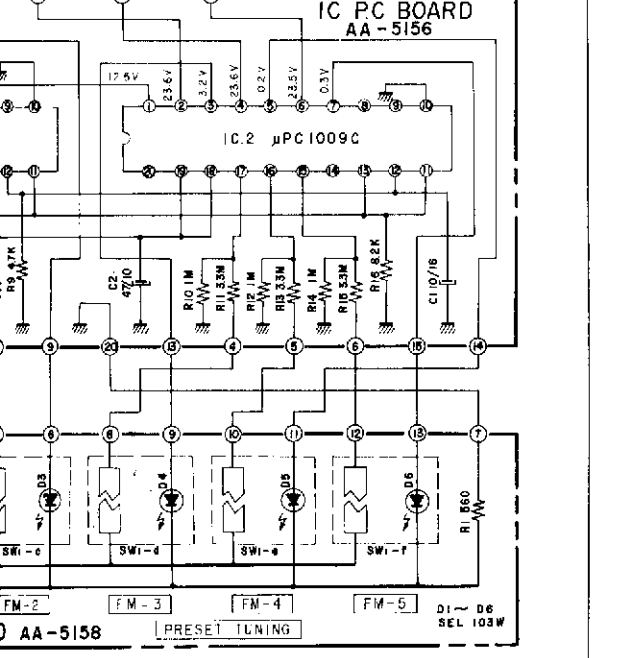
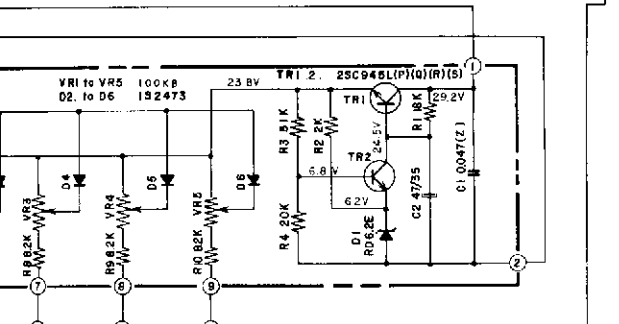
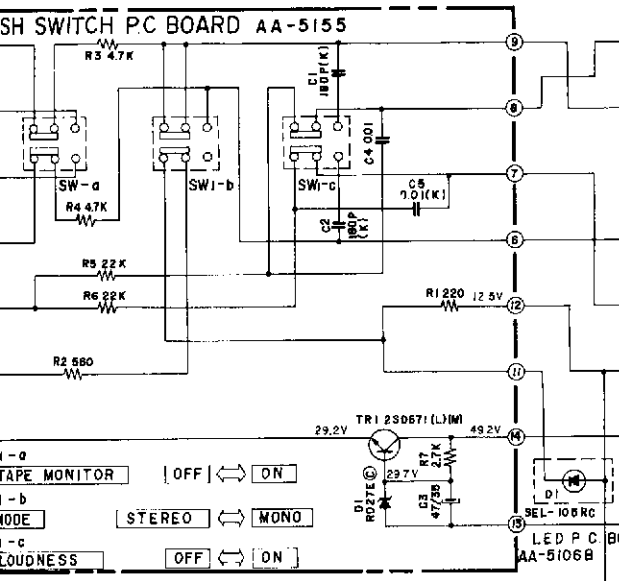

**NOTE**

1 UNLESS OTHERWISE SPECIFIED  
ALL RESISTORS IN OHMS (1/4W(J))  
ALL CAPACITORS IN µF 50WV(J)

2 POWER TRANSFORMER IS DIFFERENT  
ACCORDING TO AREA

**AA-1010L  
CONNECTION DIAGRAM  
NO. 4-1 1540214A**

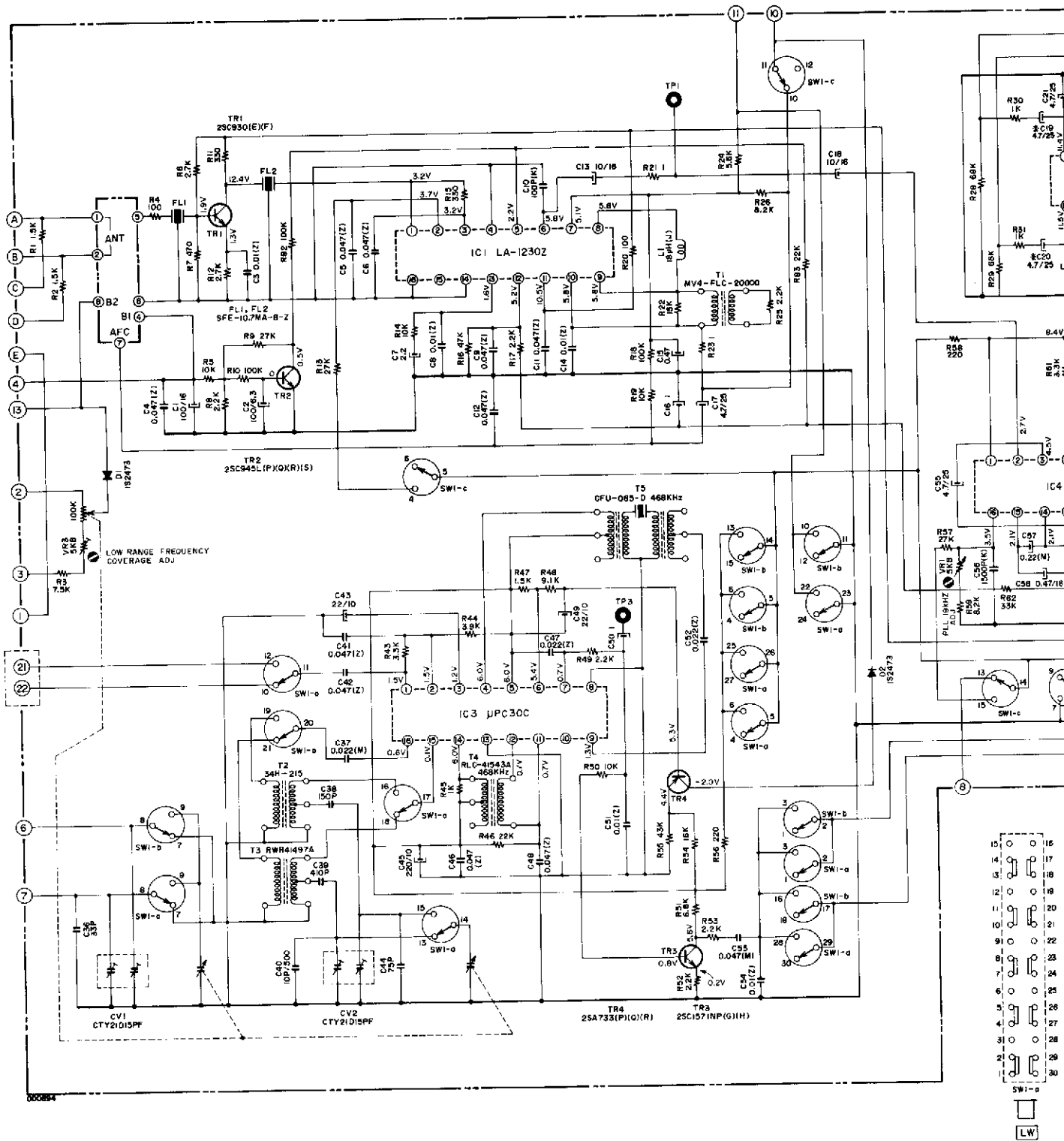

# RTV servis Horvat

Kešinci, 31402 Semeljci

Tel : 031-856-637

Tel / fax : 031-856-139

Mob : 098-788-319

[ctv-servis-horvat@os.tel.hr](mailto:ctv-servis-horvat@os.tel.hr)

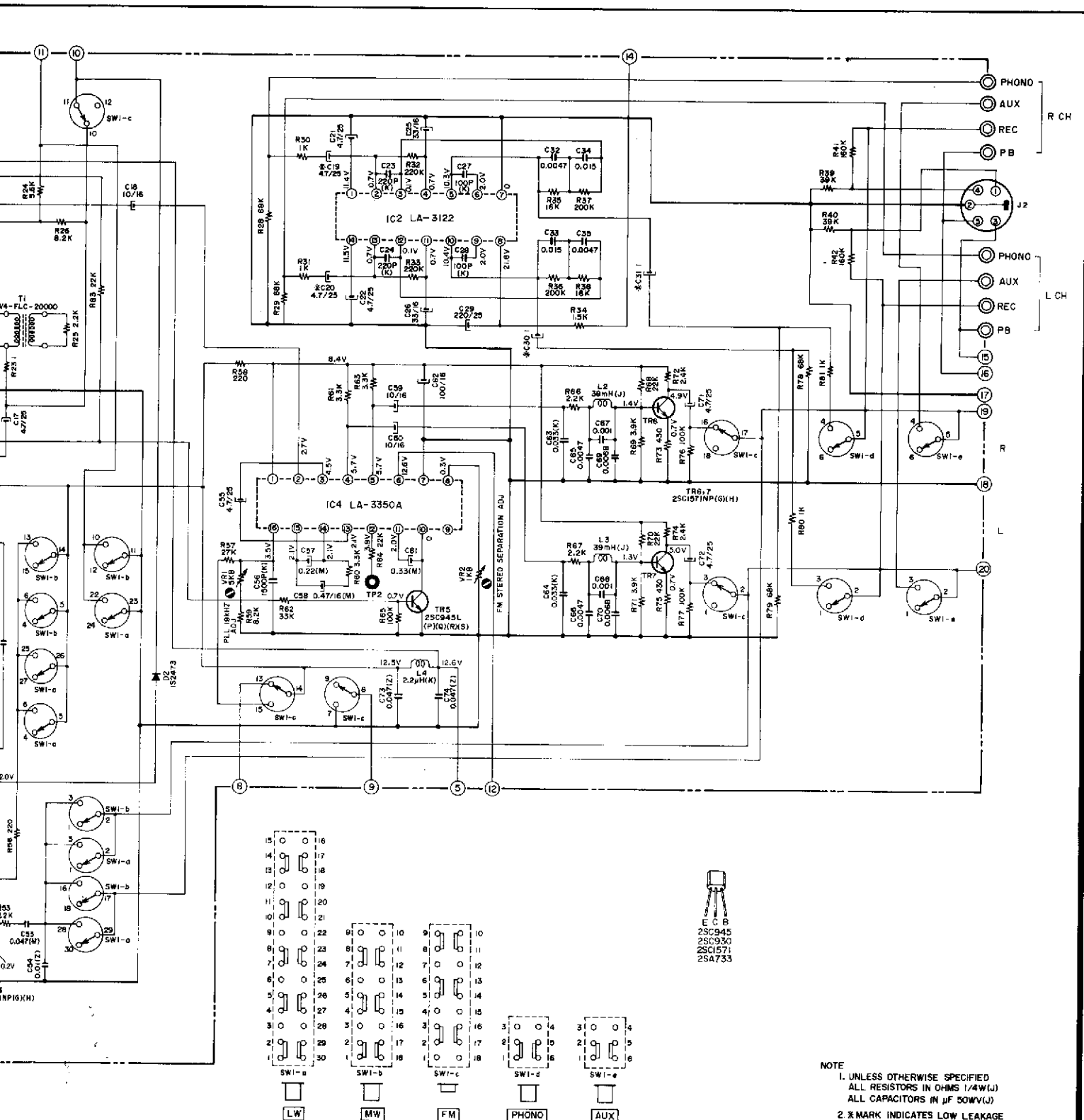

NOTE  
 1. UNLESS OTHERWISE SPECIFIED  
 ALL RESISTORS IN OHMS (1/4W(J))  
 ALL CAPACITORS IN µF 50WV(J)  
 2. X MARK INDICATES LOW LEAKAGE  
 CAPACITORS

AA-1010L MFC  
 SCHEMATIC DIAGRAM  
 No.4-2 1540215A

AA-1010L

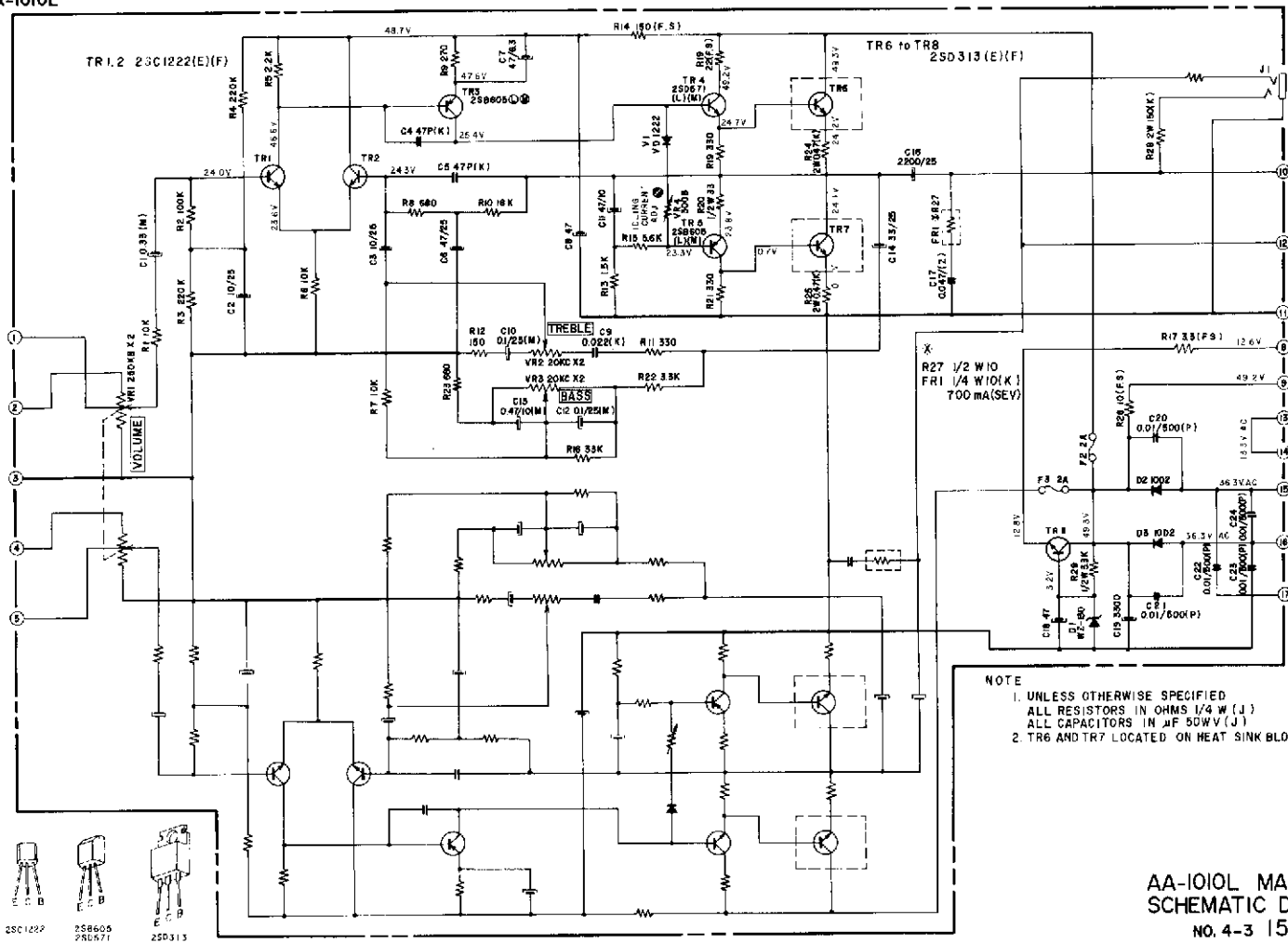

NOTE  
 1. UNLESS OTHERWISE SPECIFIED  
 ALL RESISTORS IN OHMS 1/4 W (J)  
 ALL CAPACITORS IN  $\mu$ F 50WV (J)  
 2. TR6 AND TR7 LOCATED ON HEAT SINK BLOCK

AA-1010L MAIN AMP  
 SCHEMATIC DIAGRAM  
 NO. 4-3 1540216A

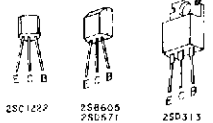

000896

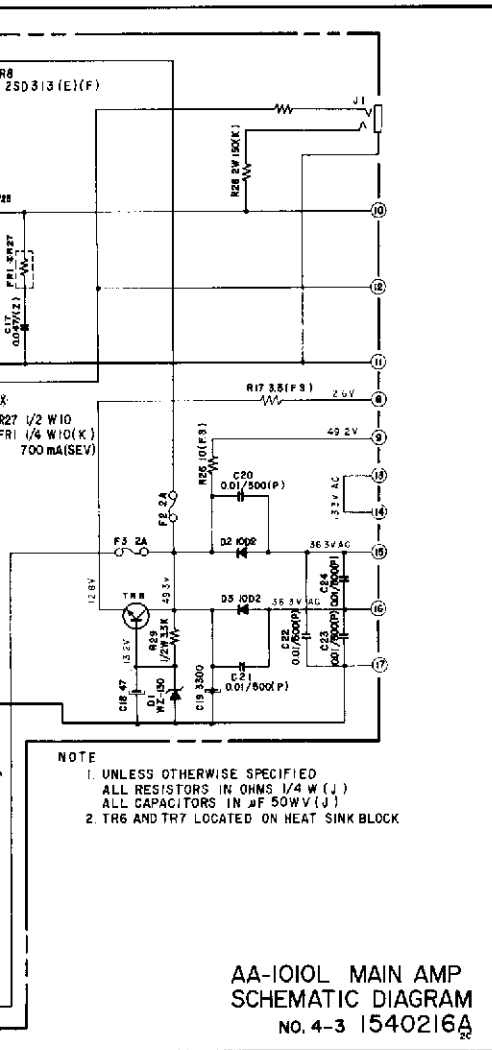

## RTV servis Horvat

Kešinci, 31402 Semeljci

Tel : 031-856-637

Tel / fax : 031-856-139

Mob : 098-788-319

rtv-servis-horvat@os.tel.hr

