

HiFi ENGINE®

For more Hi-Fi manuals and set-up information
please visit www.hifiengine.com

AKAI SERVICE MANUAL

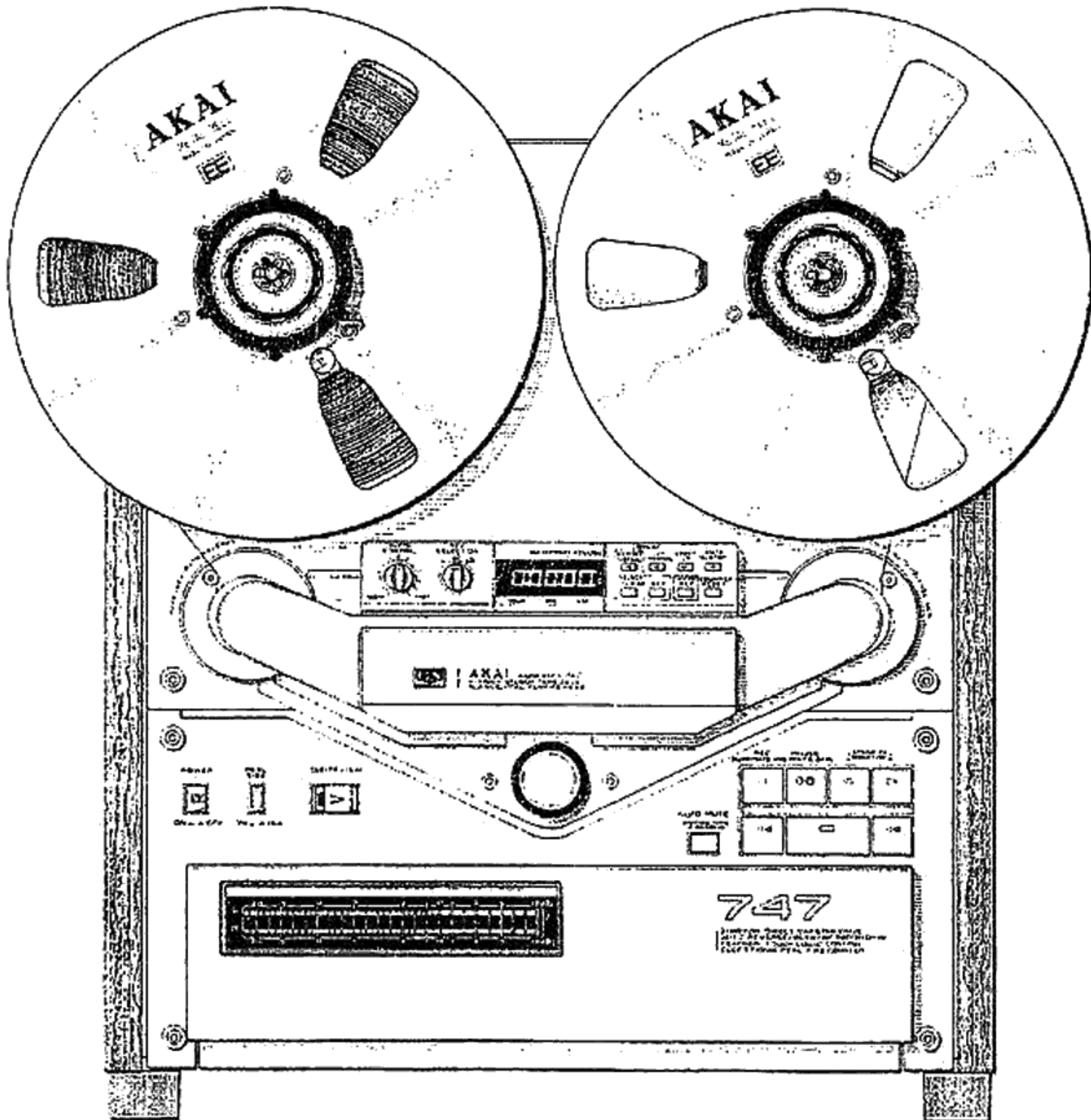

STEREO TAPE DECK

MODEL **GX-747**

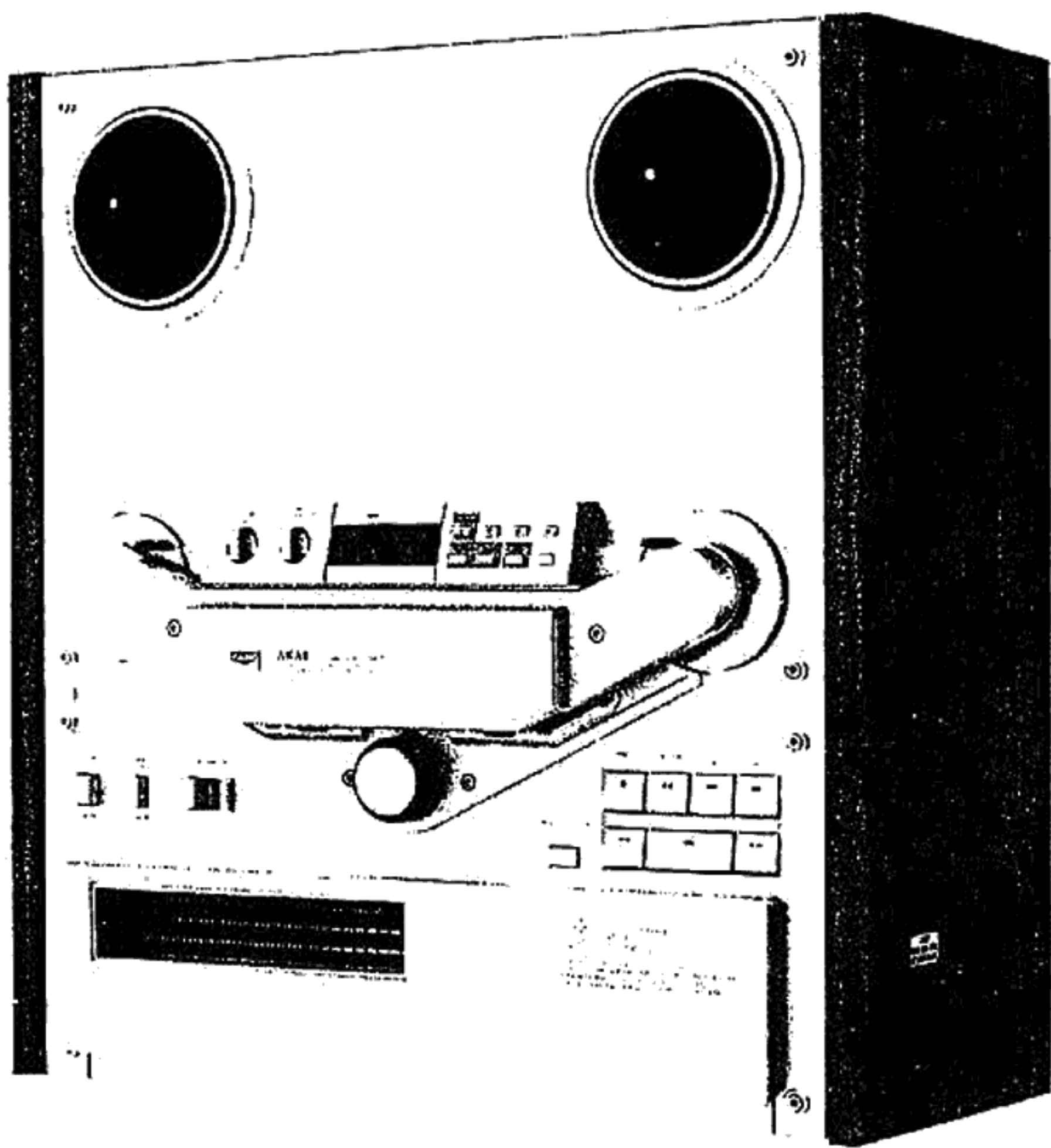

STEREO TAPE DECK

MODEL GX-747

THIS MANUAL IS APPLICABLE TO BOTH SILVER AND BLACK PANEL MODELS

SECTION 1	SERVICE MANUAL	3
SECTION 2	PARTS LIST	49
SECTION 3	SCHEMATIC DIAGRAM	64

SECTION 1

SERVICE MANUAL

TABLE OF CONTENTS

I.	SPECIFICATIONS	4
II.	DISMANTLING OF UNIT	5
III.	CONTROLS	6
IV.	PRINCIPAL PARTS LOCATION	7
V.	VOLTAGE AND CYCLE CONVERSION	8
	1. VOLTAGE CONVERSION	8
	2. CYCLE CONVERSION	8
VI.	DESCRIPTION OF CIRCUIT OPERATION	9
	1. OUTLINE	9
	2. DETAILS AND FEATURES OF EE TAPE	9
	3. EXPLANATION OF EACH OPERATING PRINCIPLES	11
VII.	MECHANISM ADJUSTMENT	22
	1. GUIDE ROLLER LOOSE PLAY ADJUSTMENT	22
	2. MICRO SWITCH POSITION ADJUSTMENT	22
	3. REEL TABLE HEIGHT ADJUSTMENT	23
	4. CAPSTAN SHAFT LOOSE PLAY ADJUSTMENT	23
	5. BRAKE BAND POSITION ADJUSTMENT AND BRAKE TENSION ADJUSTMENT	23
	6. PINCH ROLLER POSITION ADJUSTMENT	24
	7. PAUSE PLUNGER POSITION ADJUSTMENT	24
	8. PINCH ROLLER PRESSURE ADJUSTMENT	24
	9. TAPE SPEED ADJUSTMENT	25
VIII.	HEAD ADJUSTMENT	26
IX.	ELECTRICAL ADJUSTMENT	28
	1. CLOCK FREQUENCY ADJUSTMENT	28
	2. PHOTO TRANSISTOR SENSITIVITY	28
X.	DC RESISTANCE OF VARIOUS COILS	32
XI.	CLASSIFICATION OF VARIOUS P.C BOARDS	33
	1. P.C BOARD TITLES AND IDENTIFICATION NUMBERS	33
	2. COMPOSITION OF VARIOUS P.C BOARDS	34

For basic adjustments, measuring methods, and operating principles, refer to GENERAL TECHNICAL MANUAL.

I . SPECIFICATIONS

TRACK SYSTEM	4 Track 2 Channel Stereo System
REEL CAPACITY	Up to 10" reel
HEADS	GX head for Recording x 2 GX head for Playback x 2 Erase head x 2
MOTORS	AC Servo motor for capstan drive x 1 AC Eddy current motor for reel drive x 2
TAPE SPEED	19 cm/s \pm 0.8% (7-1/2 ips.) 9.5 cm/s \pm 1.0% (3-3/4 ips.)
WOW & FLUTTER	Less than 0.03% WRMS, 0.07% DIN 45500 at 19 cm/s Less than 0.04% WRMS, 0.09% DIN 45500 at 9.5 cm/s
TAPE WINDING TIME	75 sec. using 360 m (1,200 ft.) Tape
FREQUENCY RESPONSE	25 to 33,000 Hz \pm 3 dB at 19 cm/s 25 to 26,000 Hz \pm 3 dB (0 VU) 25 to 25,000 Hz \pm 3 dB at 9.5 cm/s 25 to 15,000 Hz \pm 3 dB (0 VU)
SIGNAL TO NOISE RATIO	Better than 65 dB at 19 cm/s DIN 45500
HARMONIC DISTORTION	Less than 0.4% at 19 cm/s
INPUT	MIC: 0.25 mV (input impedance 5.0 kohms) Required microphone impedance: 600 ohms Line: 70 mV (input impedance 100 kohms)
OUTPUT	Line: 0.775 V at 0 VU Required load impedance: more than 20 kohms Phone: 100 mV/8 ohms at 0 VU
DIN	Input: 2 mV (input impedance 10 kohms) Output: 0.3 V Required load impedance: more than 20 khoms
POWER REQUIREMENTS	100 V, 50/60 Hz for Japan 120 V, 60 Hz for USA & Canada 220 V, 50 Hz for Europe except UK 240 V, 50 Hz for UK & Australia 110 V/120 V/220 V/240 V, 50/60 Hz switchable for the other countries.
POWER CONSUMPTION	JPN 80W CSA, AAL 140W U/T 140W
DIMENSIONS	440 (W) x 483 (H) x 256 (D) mm (17.3 x 19.0 x 10.1 inches)
WEIGHT	21 kg (46.4 lbs)

* For improvement purposes, specifications and design are subject to change without notice.

II. DISMANTLING OF UNIT

In case of trouble, etc. necessitating dismantling, please dismantle in the order shown in the photographs. Reassemble in reverse order.

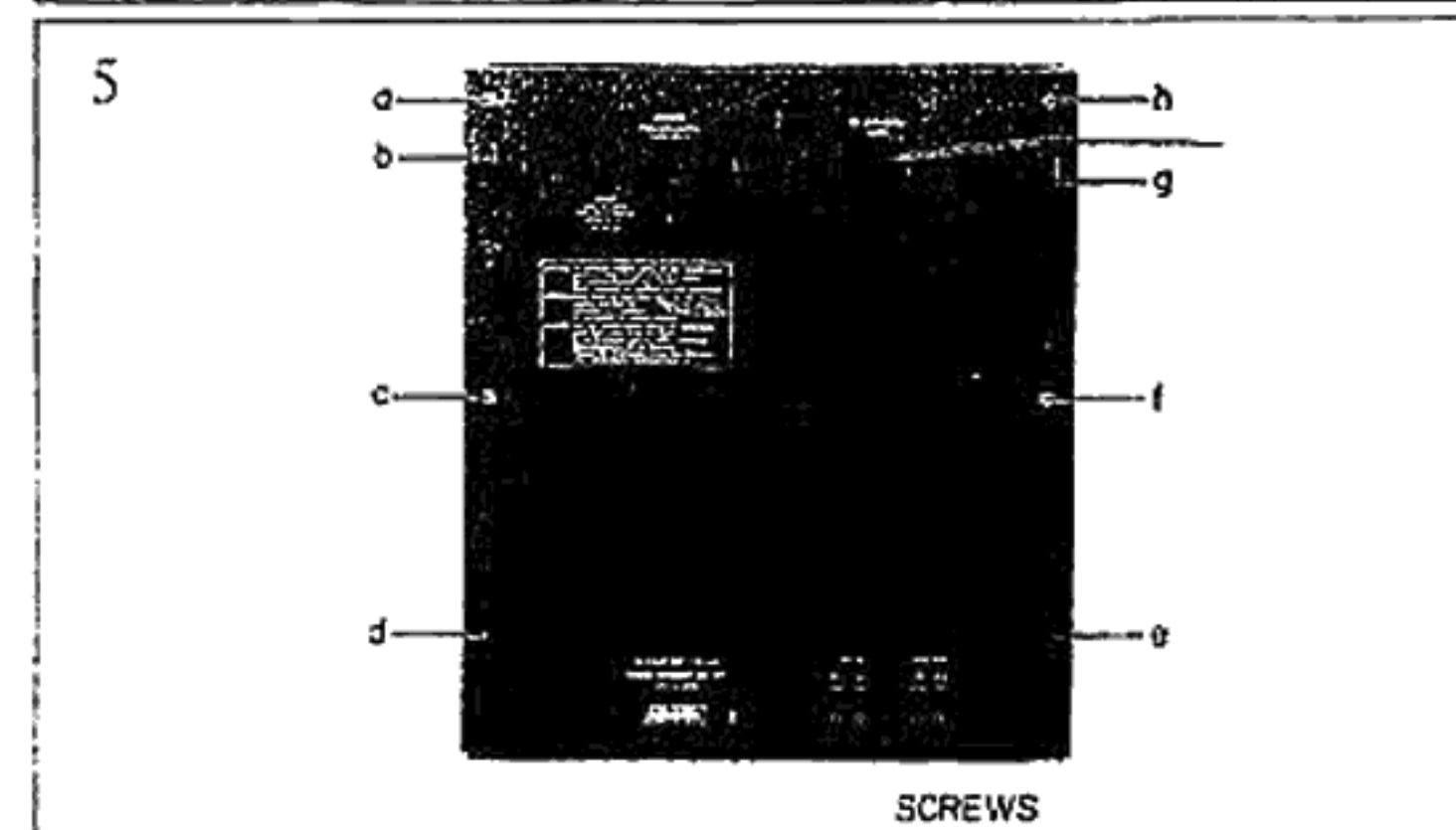
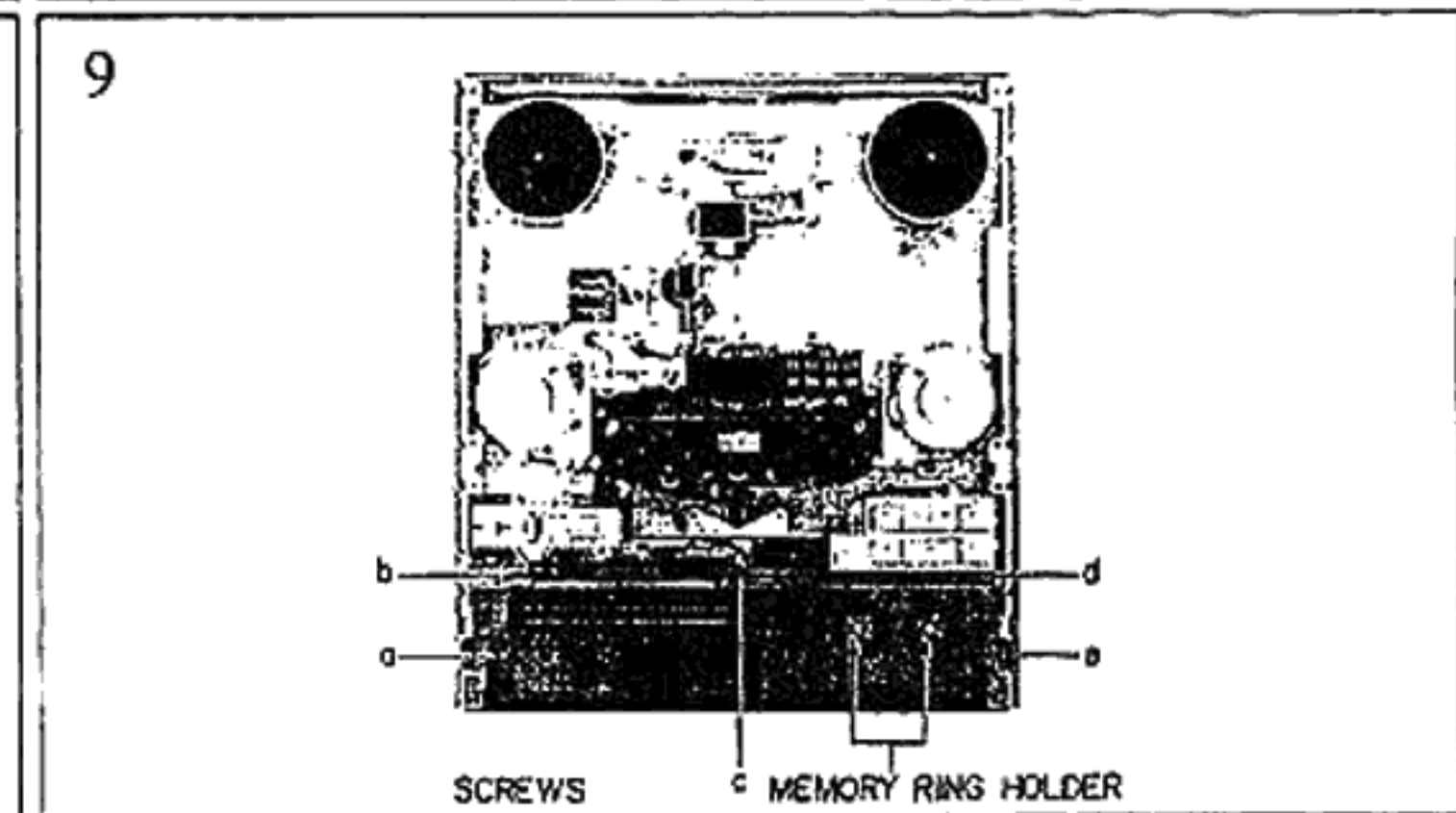
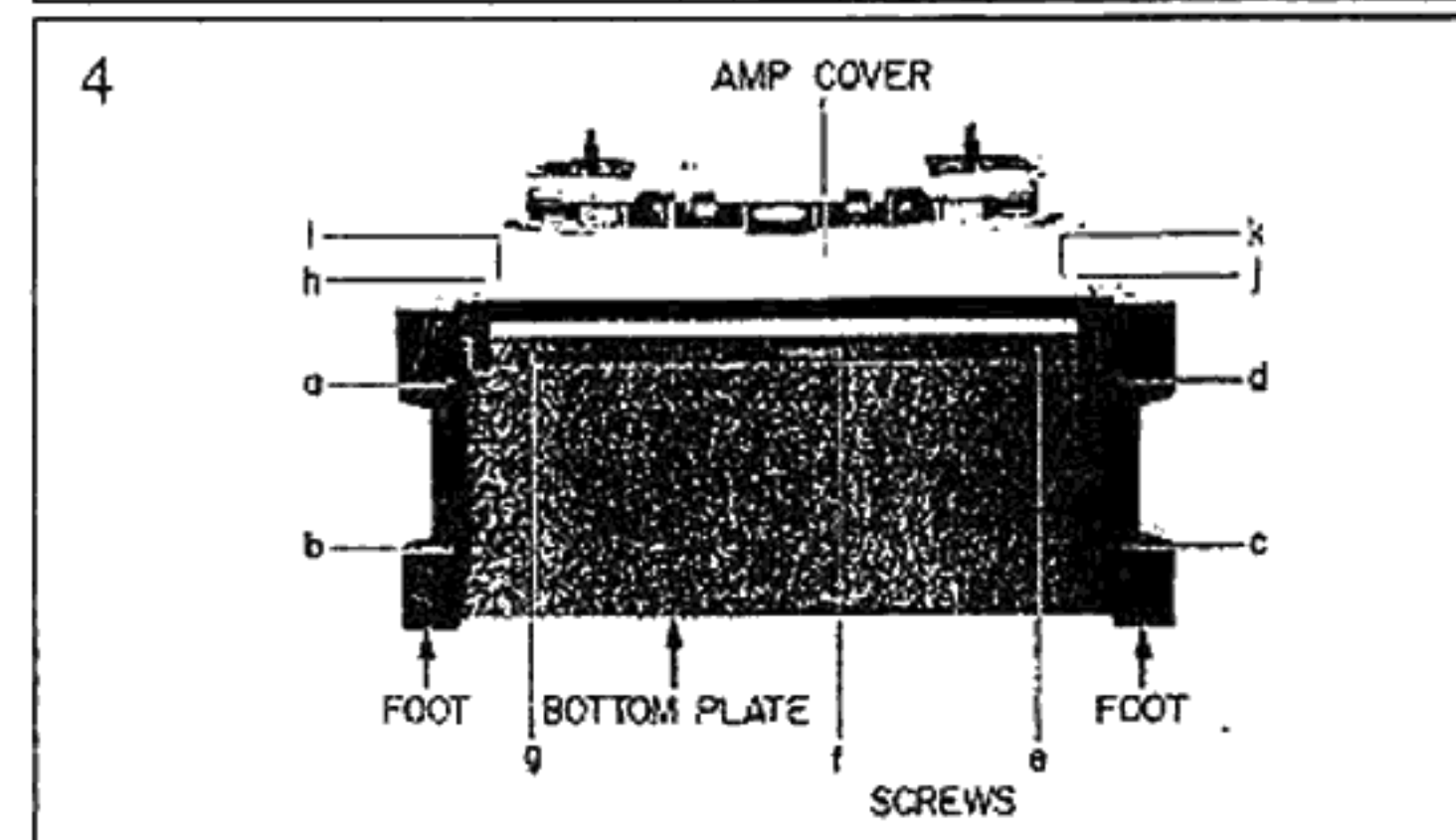
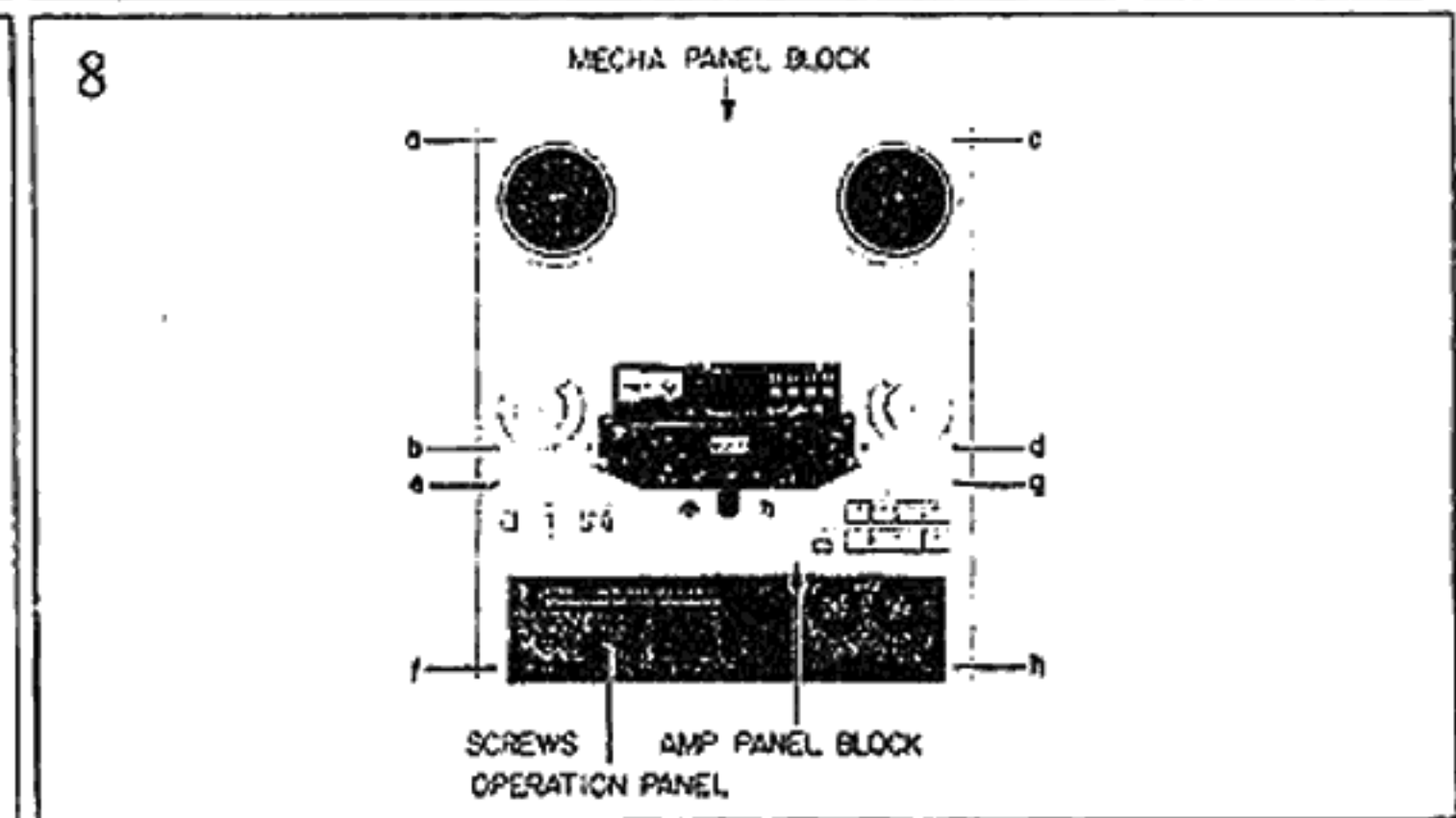
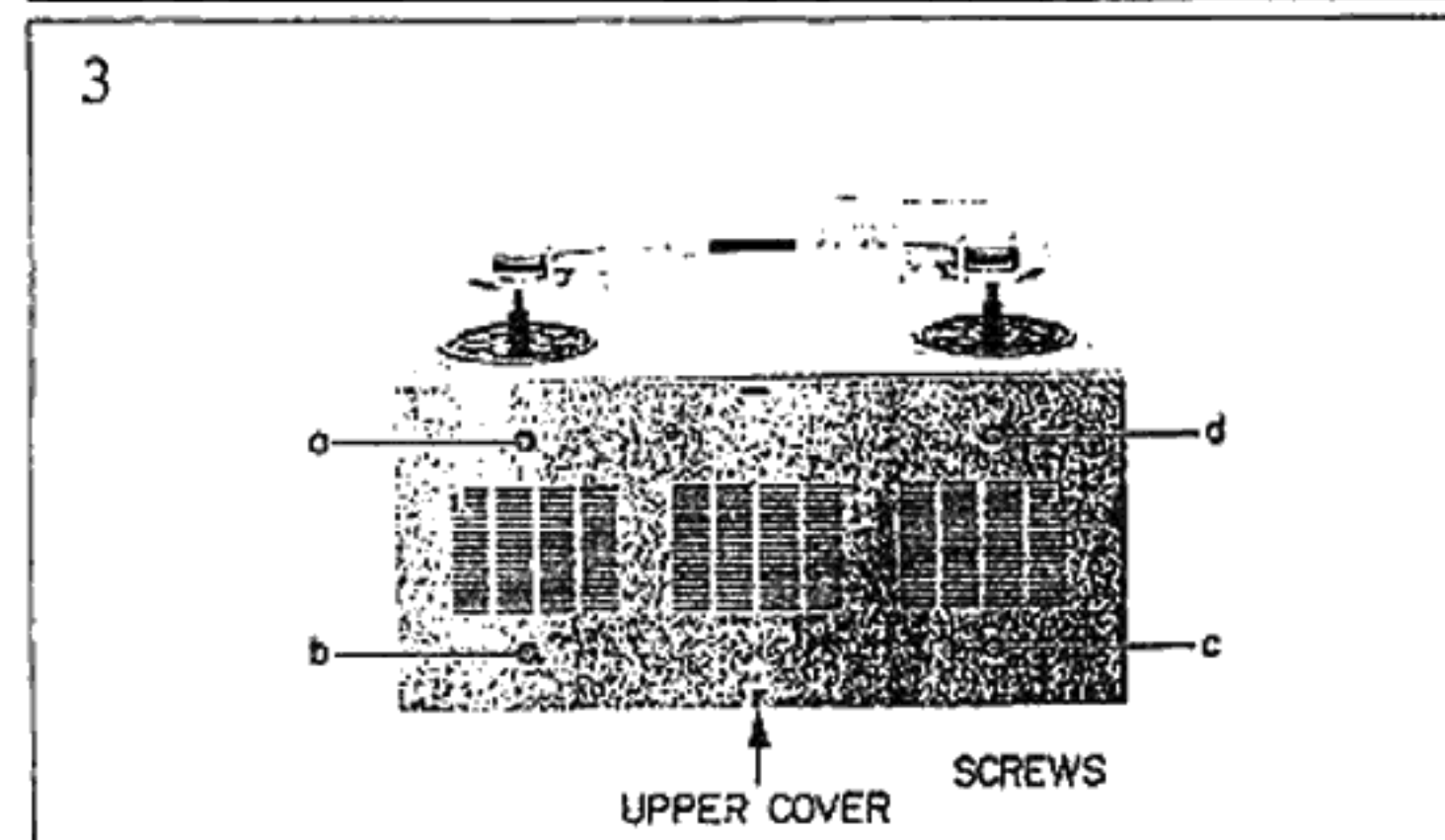
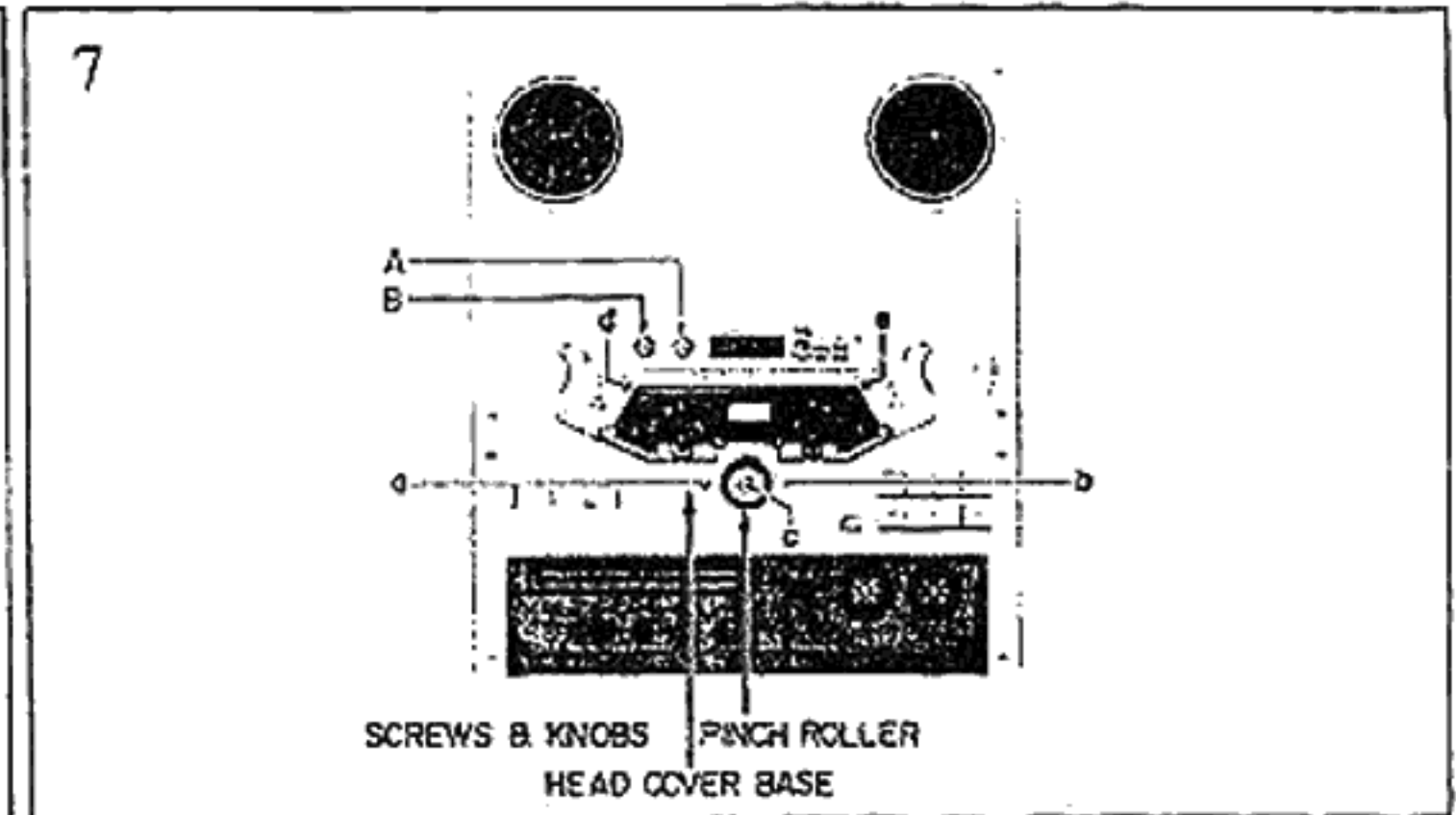
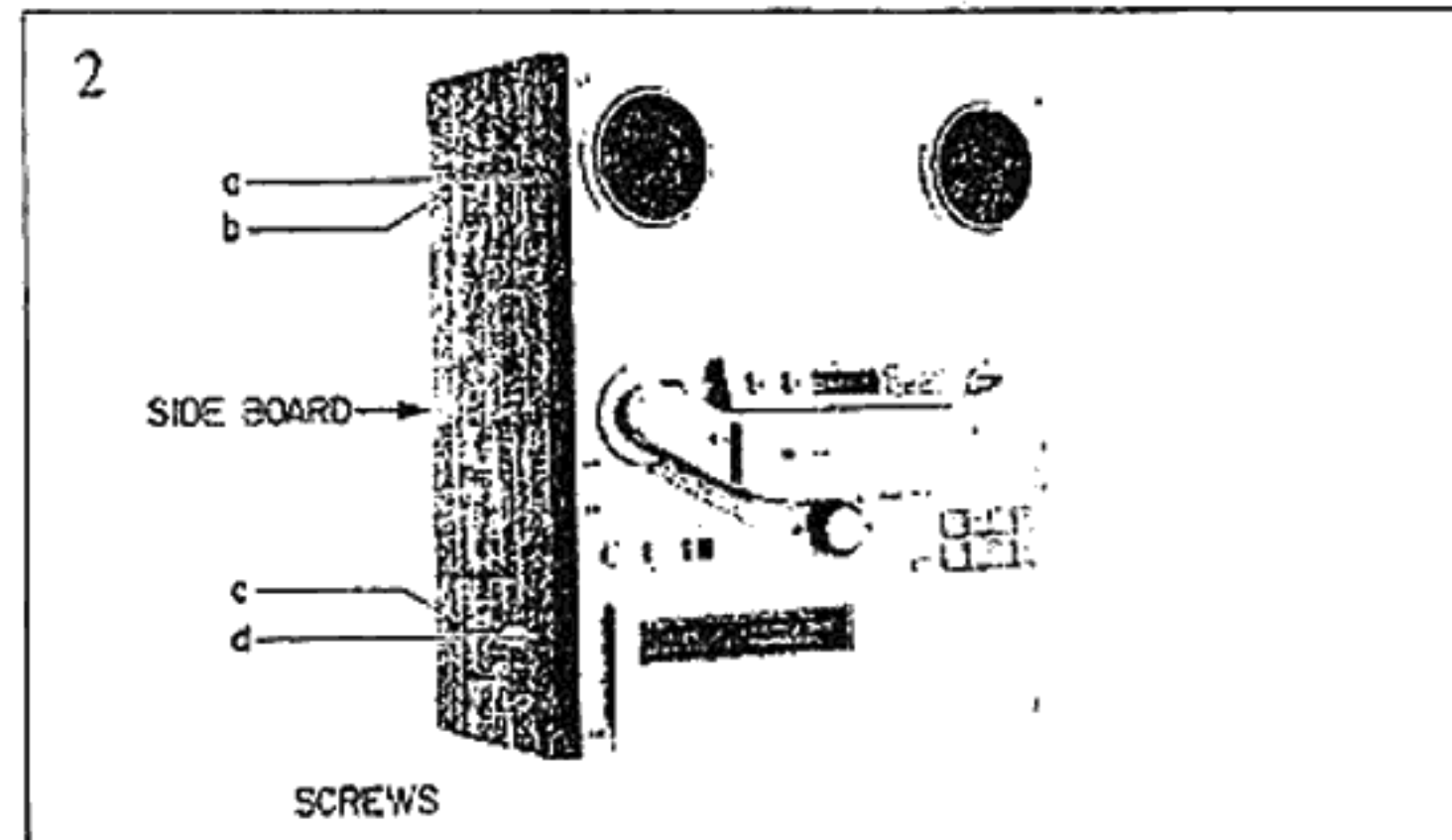
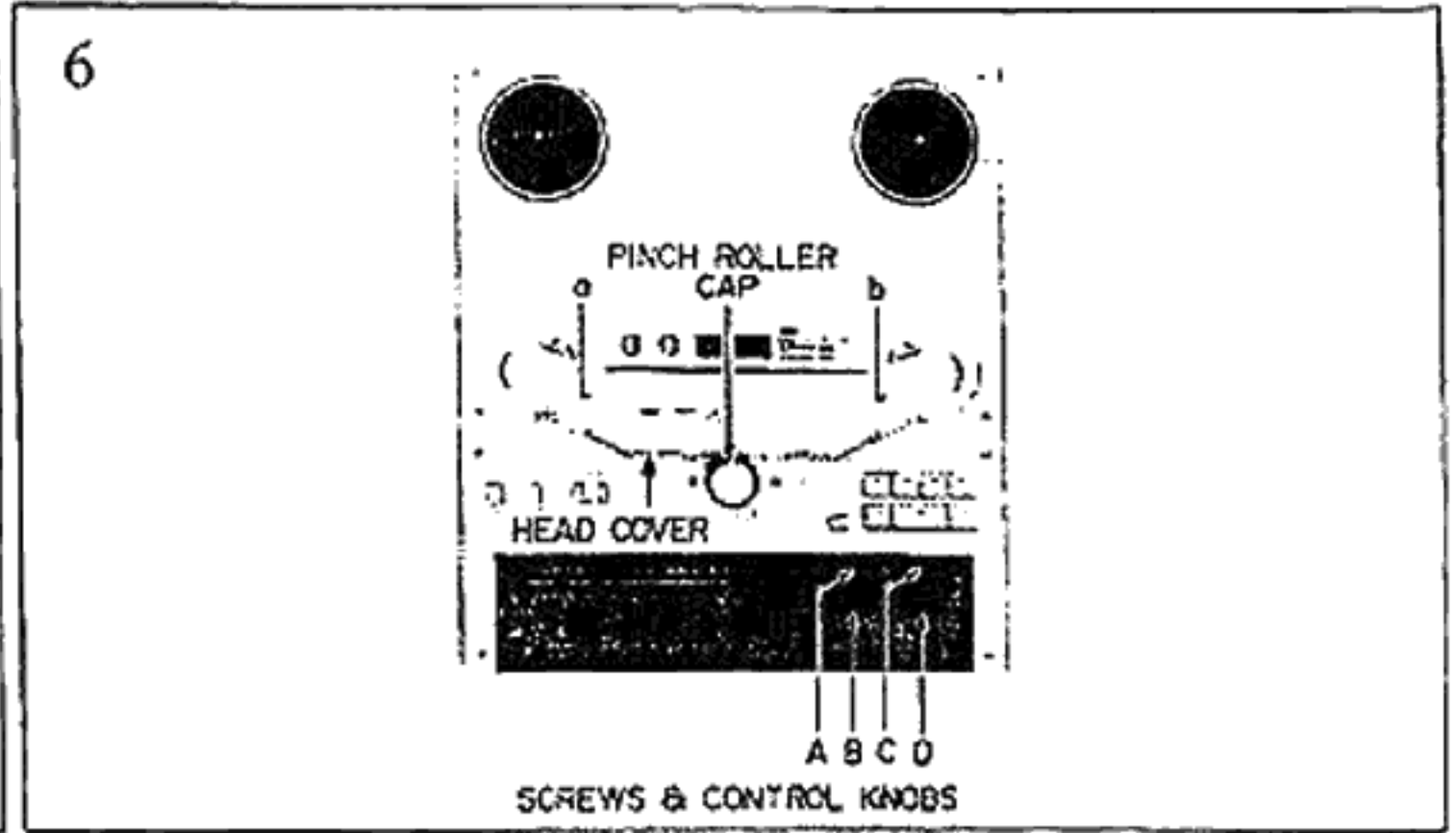
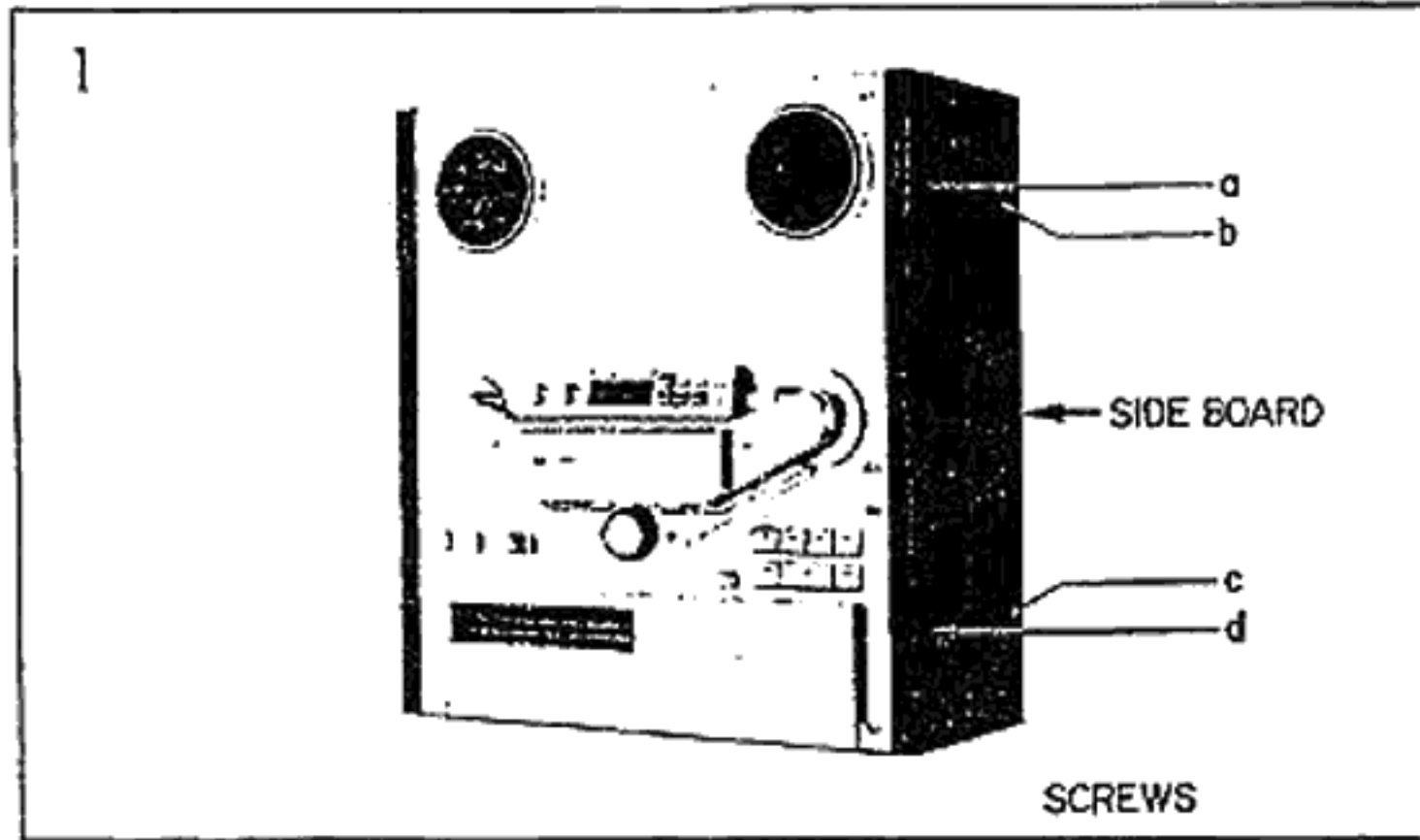

III. CONTROLS

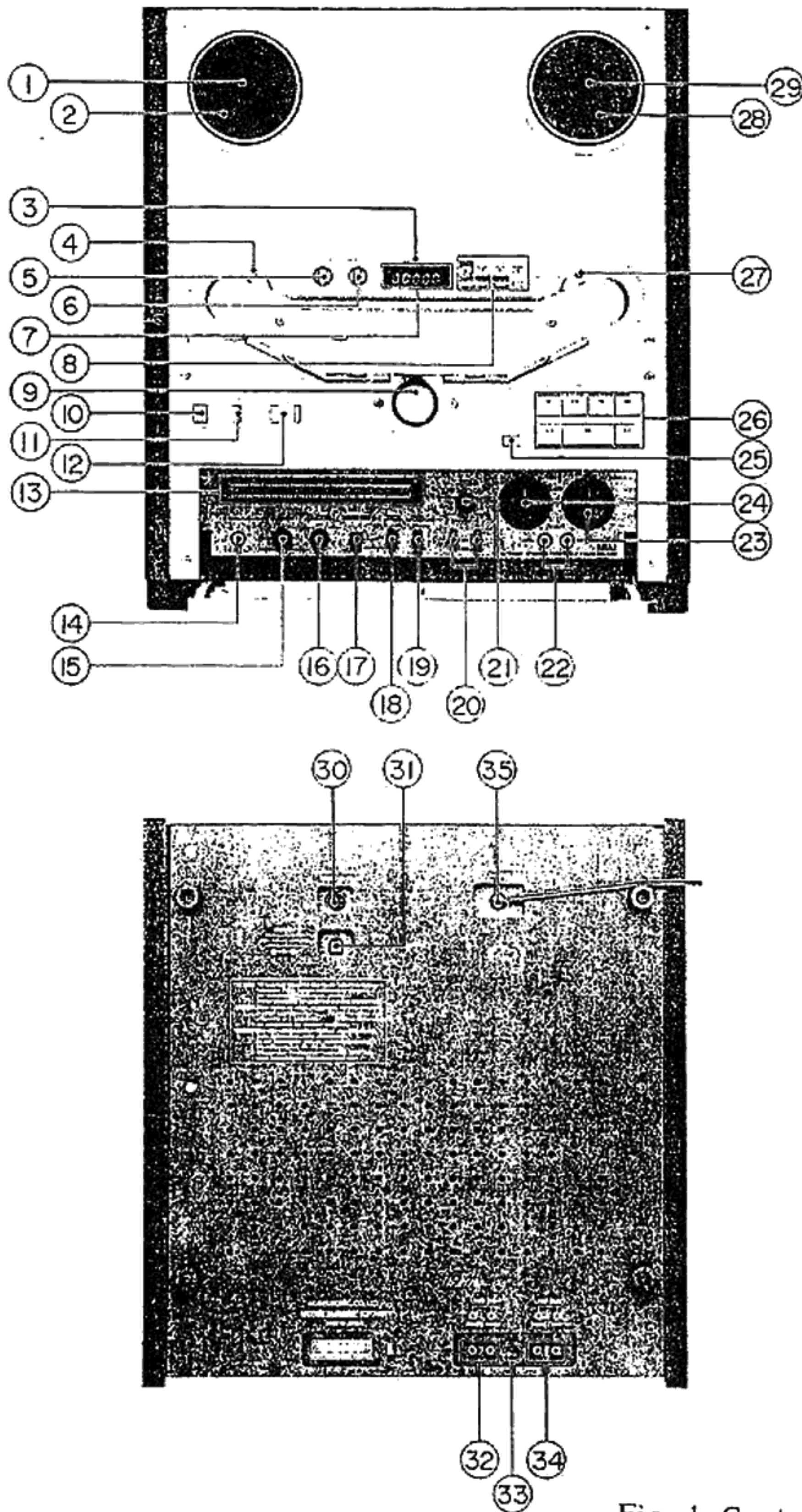

Fig. 1 Controls

- | | |
|--|--|
| 1. BUILT-IN REEL RETAINER | 18. TAPE SPEED SELECTOR |
| 2. SUPPLY REEL TABLE | 19. TAPE SELECTOR SWITCH |
| 3. MEMORY REVERSE INDICATOR | 20. TRACK SELECTOR SWITCHES |
| 4. LEFT TENSION ARM (SENSING PIN) | 21. BIAS ADJUSTMENT VOLUME |
| 5. PITCH CONTROL | 22. MICROPHONE JACKS |
| 6. REVERSE SELECTOR SWITCH | 23. LINE INPUT CONTROLS |
| 7. ELECTRONIC DIGITAL REAL TIME COUNTER | 24. MICROPHONE INPUT CONTROLS |
| 8. AUTO TIME COUNTER SYSTEM | 25. AUTO MUTE BUTTON |
| 9. PINCH ROLLER | 26. OPERATING BUTTONS |
| 10. POWER SWITCH | 27. RIGHT TENSION ARM (SENSING PIN) |
| 11. REEL SIZE SELECTOR | 28. TAKE-UP REEL TABLE |
| 12. CUE/REVIEW LEVER | 29. BUILT-IN REEL TABLE |
| 13. LED BAR METERS (JPN MODEL VU METERS) | 30. REMOTE CONTROL JACK |
| 14. HEADPHONE JACK | 31. AC ADAPTER JACK |
| 15. OUTPUT LEVEL CONTROL | 32. LINE IN JACKS |
| 16. TIMER START SWITCH | 33. DIN JACK (Some Models do not have this facility) |
| 17. MONITOR SELECTOR | 34. LINE OUT JACKS |
| | 35. POWER CORD |

IV. PRINCIPAL PARTS LOCATION

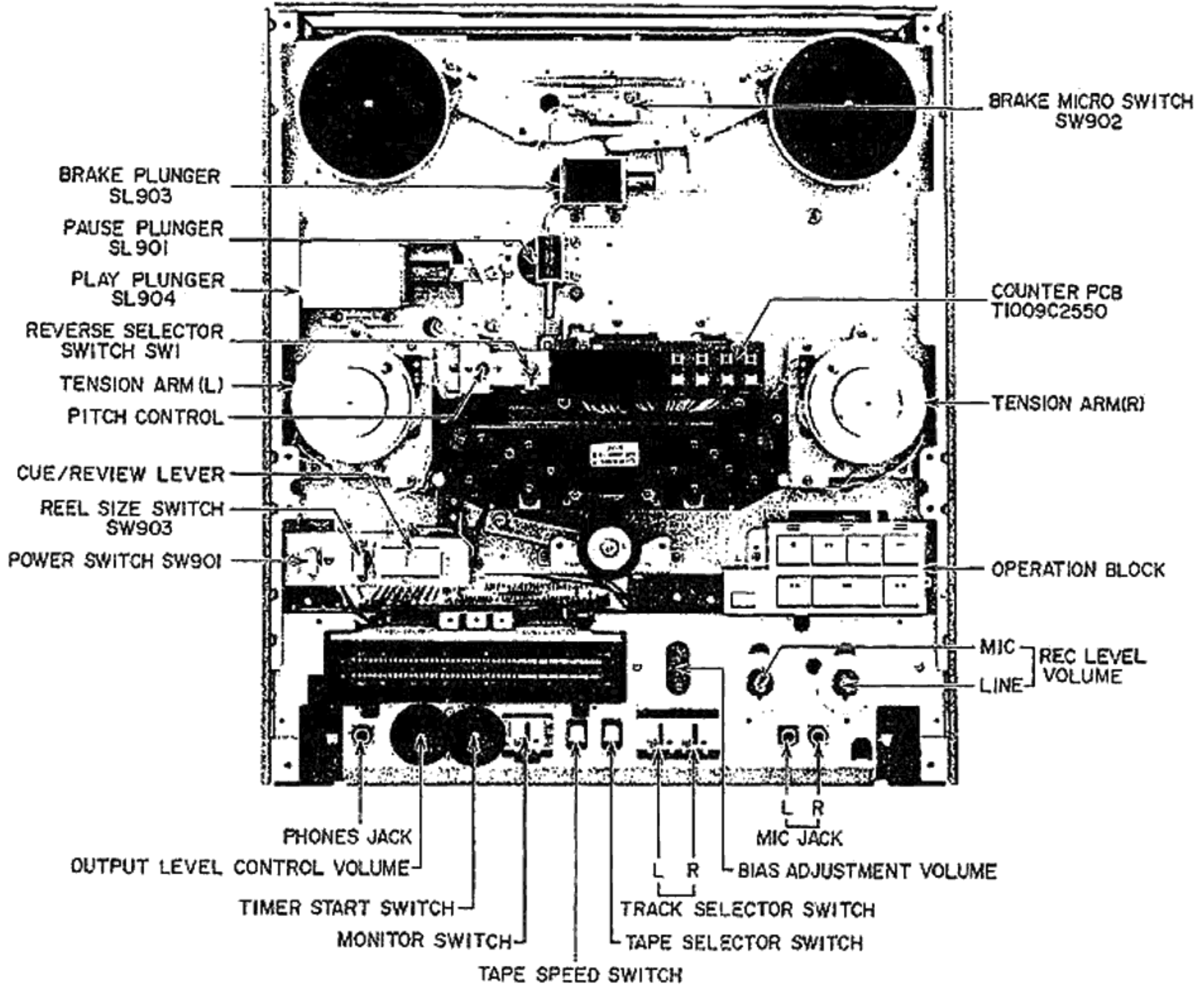

Fig. 2 Front View

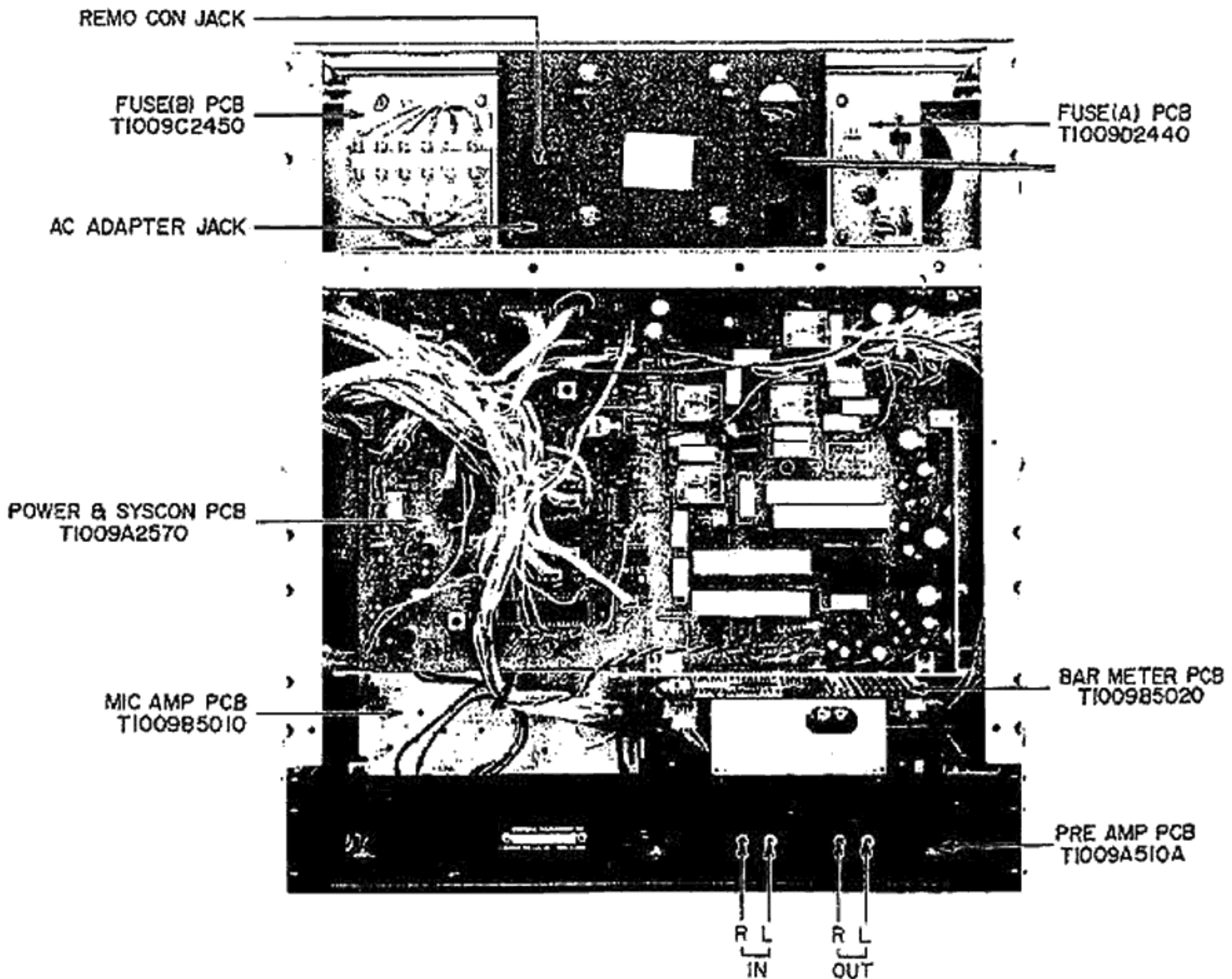

Fig. 3 Rear View

V. VOLTAGE AND CYCLE CONVERSION

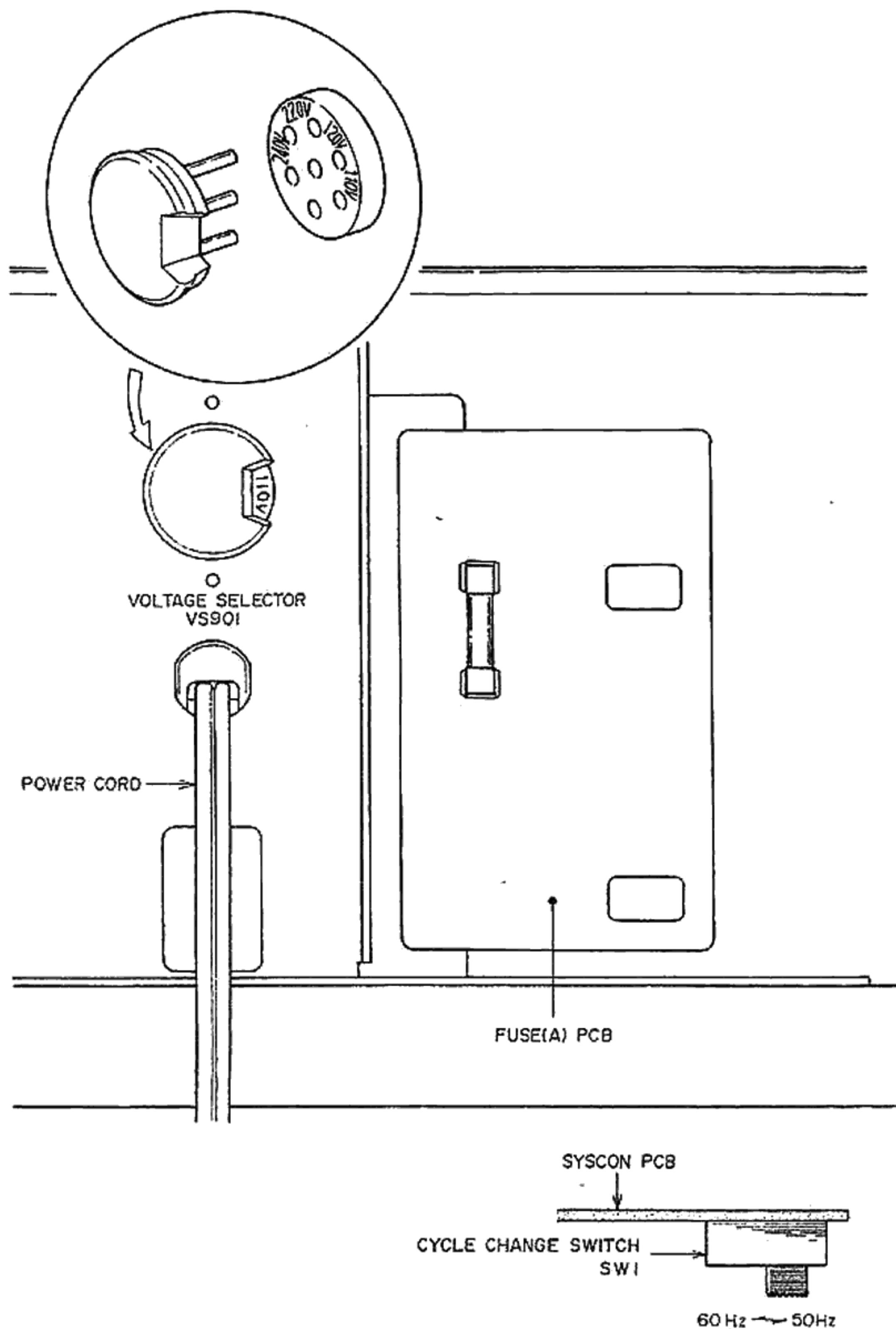

Fig. 4 Voltage Conversion (U/T Model) and Cycle Conversion (U/T, JPN Model)

1. VOLTAGE CONVERSION (Refer to Fig. 4)

- 1) JPN Model (100V, 50/60 Hz)
CSA, AAL Model (120V, 60 Hz)
CEE Model (220V, 50 Hz)
UK, SAA Model (240V, 50 Hz)
Voltage can not be switched.
- 2) U/T Model (110V/120V/220V/240V, 50/60 Hz)
Remove the back board and look for the voltage selector on the upper right portion of the machine. Change the position of voltage selector plugs so that the voltage to be used coincides with the voltage shown through the opening of voltage selector plug. Fuse change is not necessary.

2. CYCLE CONVERSION (Refer to Fig. 4)

Cycle can be converted only in U/T, JPN Model. Remove the back board and select the position of switch located in the recess at right portion of Syscon P.C Board to correspond to the frequency of power to be used. Move the switch to the right for 50 Hz and to the left for the 60 Hz.

VI. DESCRIPTION OF CIRCUIT OPERATION

The mechanism of GX-747 is based on GX-635D and the counter system and reel motor brake system on GX-625. Therefore, each block will be described in comparison with GX-635D and GX-625.

1. OUTLINE

The open deck has made a progress by increasing the performance of deck itself from 4 track 19 cm/sec. to 2 track 38 cm/sec. On the other hand, the cassette has tried to catch up with the performance of the open deck by rapidly improving the software, i. e., the recording tape.

But now for the open deck, too, a software, EE tape (extra efficiency tape) has been developed adding an advantage to the special features of the open deck such as long time recording and wide dynamic range. By using the EE tape, GX-747 9.5 cm/sec. will have the same performance as that of the conventional 19 cm/sec., and the largest shortcoming of the open deck, i. e., troublesome tape loading has been eliminated by using the power lock system (tension arm is automatically locked by motor).

2. DETAILS AND FEATURES OF EE TAPE

- 1) "High range MOL" can be improved and "high linearity" can be obtained by using the cobalt addition type magnetic substance having high coercive force.
- 2) Playback equalizer of EE tape position

Tape Speed	Conventional Type	EE Position
38 cm/sec.	NAB 3,180 μ S + 50 μ S	NAB 3,180 μ S + 35 μ S
19 cm/sec.	NAB 3,180 μ S + 50 μ S	NAB 3,180 μ S + 35 μ S
9.5 cm/sec.	NAB 3,180 μ S + 90 μ S	NAB 3,180 μ S + 50 μ S
4.75 cm/sec.	NAB 3,180 μ S + 90 μ S	NAB 3,180 μ S + 70 μ S

- 3) The REC bias is set 30% or more larger than the conventional position.
- 4) Since the REC equalizer has high peaking frequency and less equalizing amount, the transient characteristic is improved.

Improvement in Record/Playback S/N ratio

Tape Speed (cm/s)	Tape Type	1 kHz Noise Level (dB)	10 kHz Noise Level (dB)
19	EE Tape	-74	-66
	Conventional Hi Fi Tape	-71	-63
9.5	EE Tape	-71	-66
	Conventional Hi Fi Tape	-71	-62

Fig. 5

Improvement in MOL (3% distortion level)

Tape Speed (cm/s)	Tape Type	1 kHz (VU)	10 kHz (VU)	15 kHz (VU)	20 kHz (VU)
19	EE Tape	+15	+10	+8	+5
	Conventional Hi Fi Tape	+15	+7	+3	+0.5
9.5	EE Tape	+14	+4	0	
	Conventional Hi Fi Tape	+13	+1	-6	

Fig. 6

10 kHz D Range Comparison

Tape Speed (cm/s)	Tape Type	10 kHz MOL Noise Level (dB)	10 kHz D Range (dB)
19	EE Tape	+10 ~ -66	76
	Conventional Hi Fi Tape	+ 6 ~ -63	70
9.5	EE Tape	+ 4 ~ -66	70
	Conventional Hi Fi Tape	+ 1 ~ -62	63

Fig. 7

F characteristics comparison of newly developed EE tape and conventional Hi Fi Tape

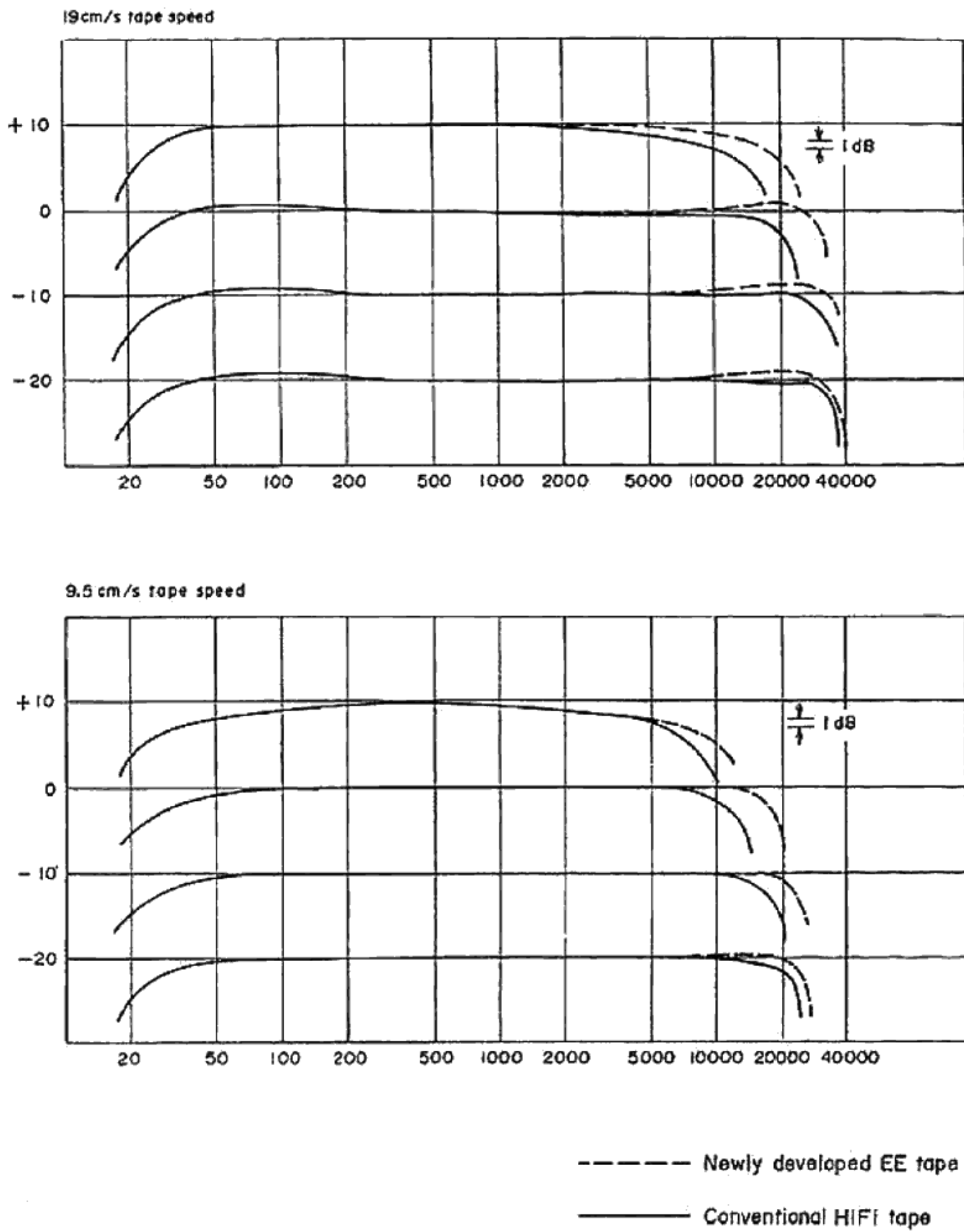

Fig. 8

S/N Ratio for Record/Playback

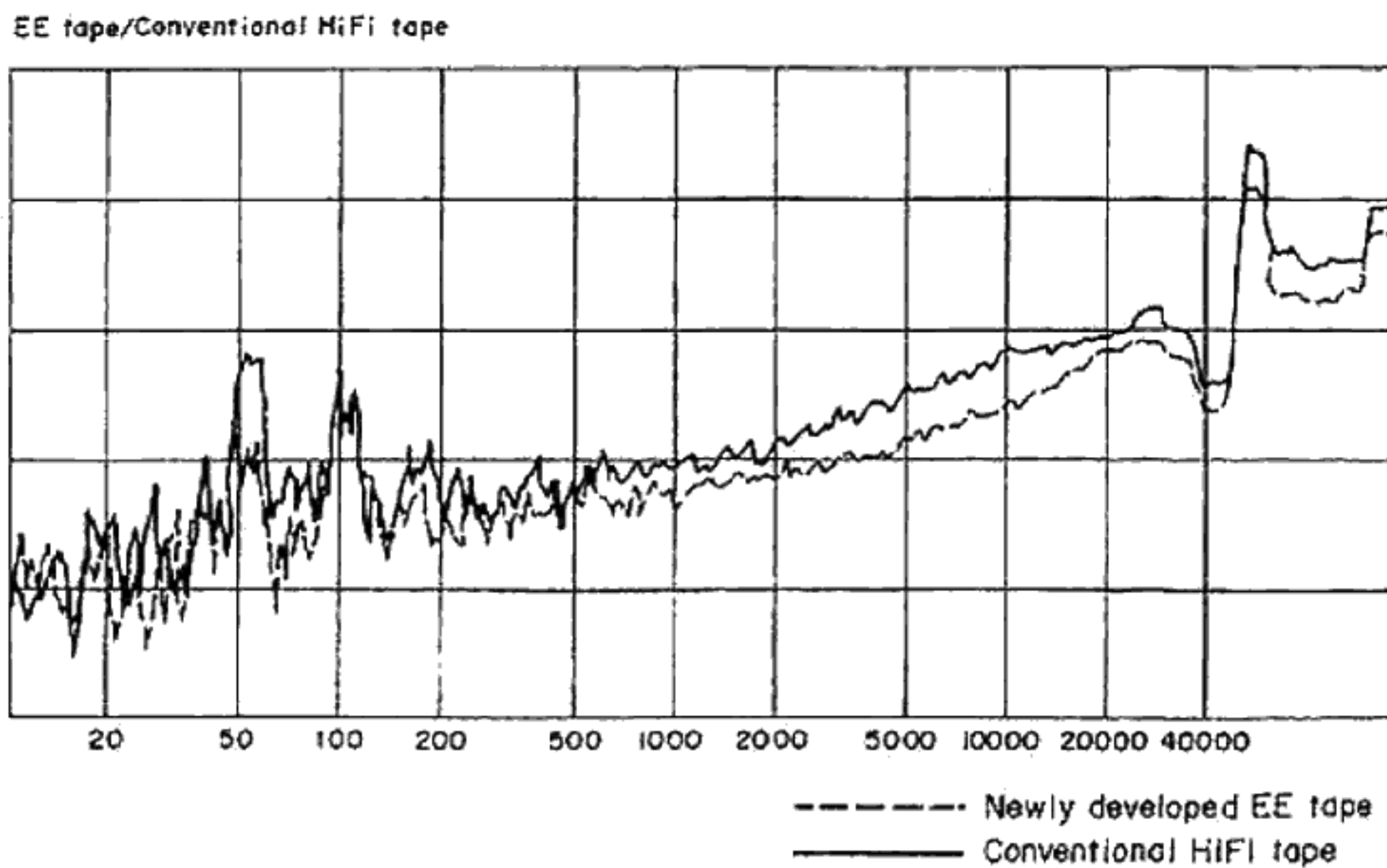

Fig. 9

3. EXPLANATION OF EACH OPERATING PRINCIPLES

Amplifier Block Diagrams

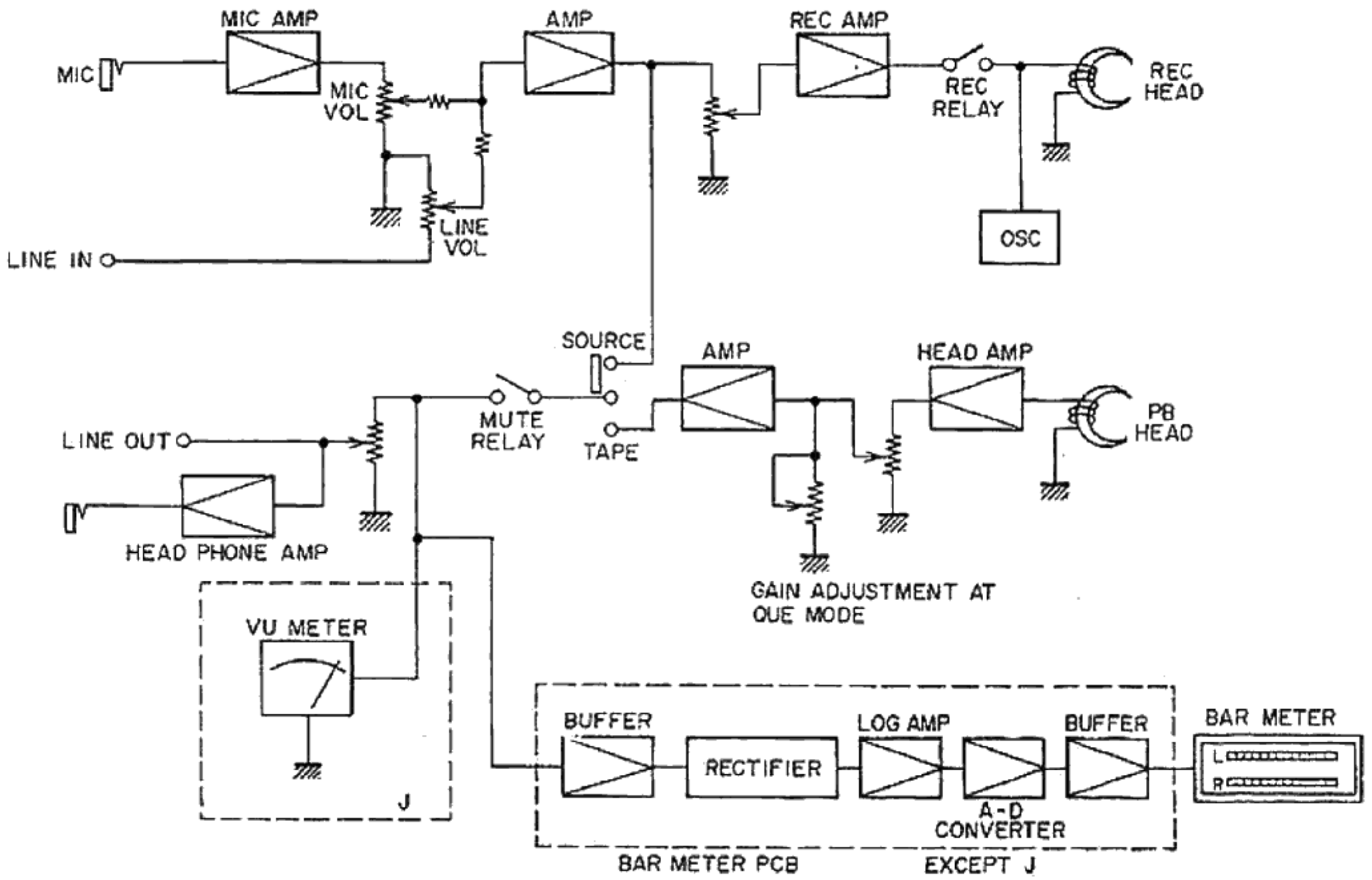

Fig. 10

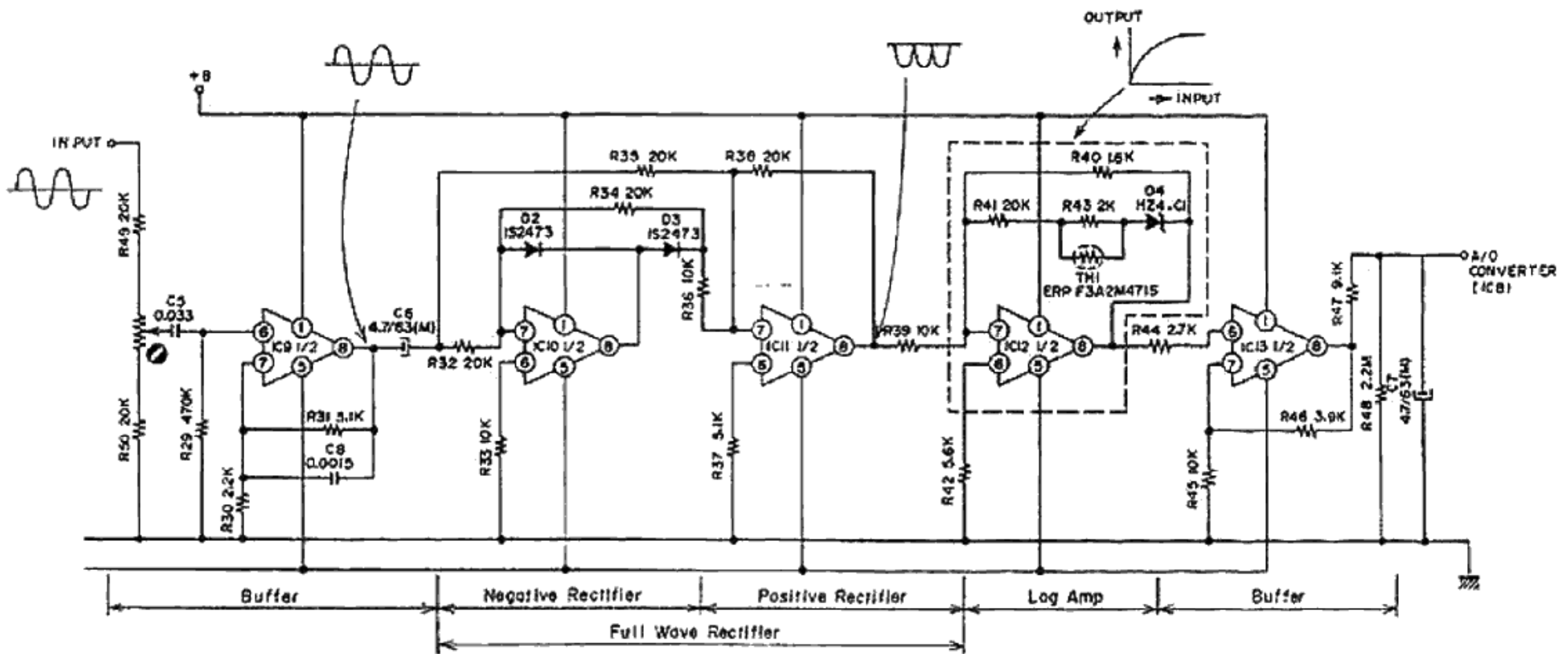

Fig. 11

1) Bar Meter Circuit (Refer to Fig. 11)

The input from the pre amplifier passes IC9, C6 and R32, and the positive signal passes D2, D3 and R36 and enters IC11. The negative signal enters the noninversion input of IC10, being inverted by the output of IC10 and inputted into IC11 and then outputted from IC11 as a

waveform both rectified. It passes the log amplifier consisting of IC12, R40, R43 and D4, and after passing IC13, it is rectified by R47 and C7 and inputted into the A/D converter of IC8. The IC8 with a peak holding function determines the maximum holding time by the time composed by C1 and R25 (left) and C2 and R26 (right).

2) System Control

The system control circuit using a microcomputer will carry out the following controls.

- ① Operational Control of tension arm lock
- ② Indication of real time counter
- ③ Operation control of function SW
- ④ Control of reel motor brake system
- ⑤ Flashing control of indication lamps

Since the LED indicator and the electronic counter indicator are operated by the timing of pulse, no tester can find the failure.

The failure can only be found by checking the waveform on the oscilloscope.

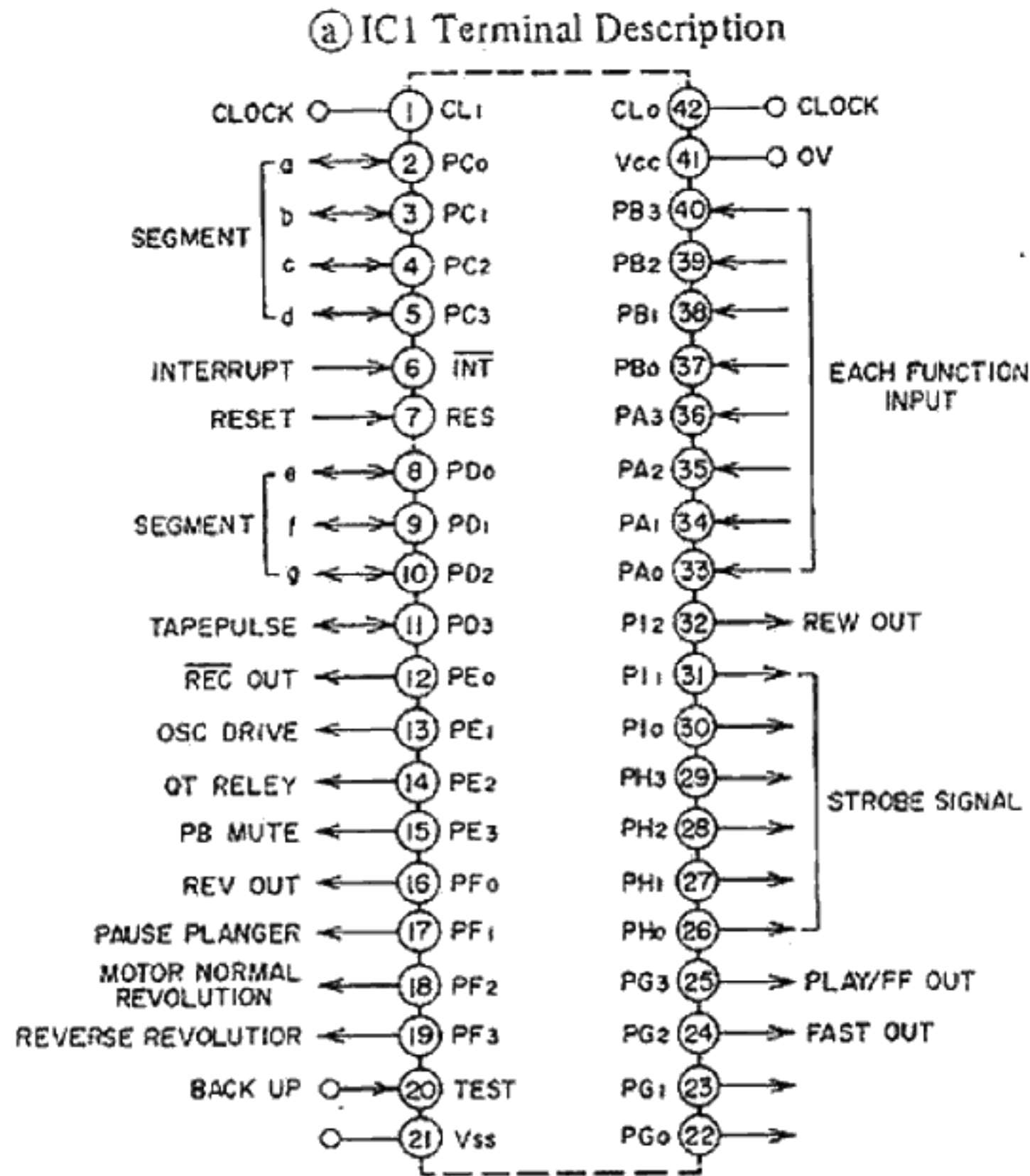

Fig. 12

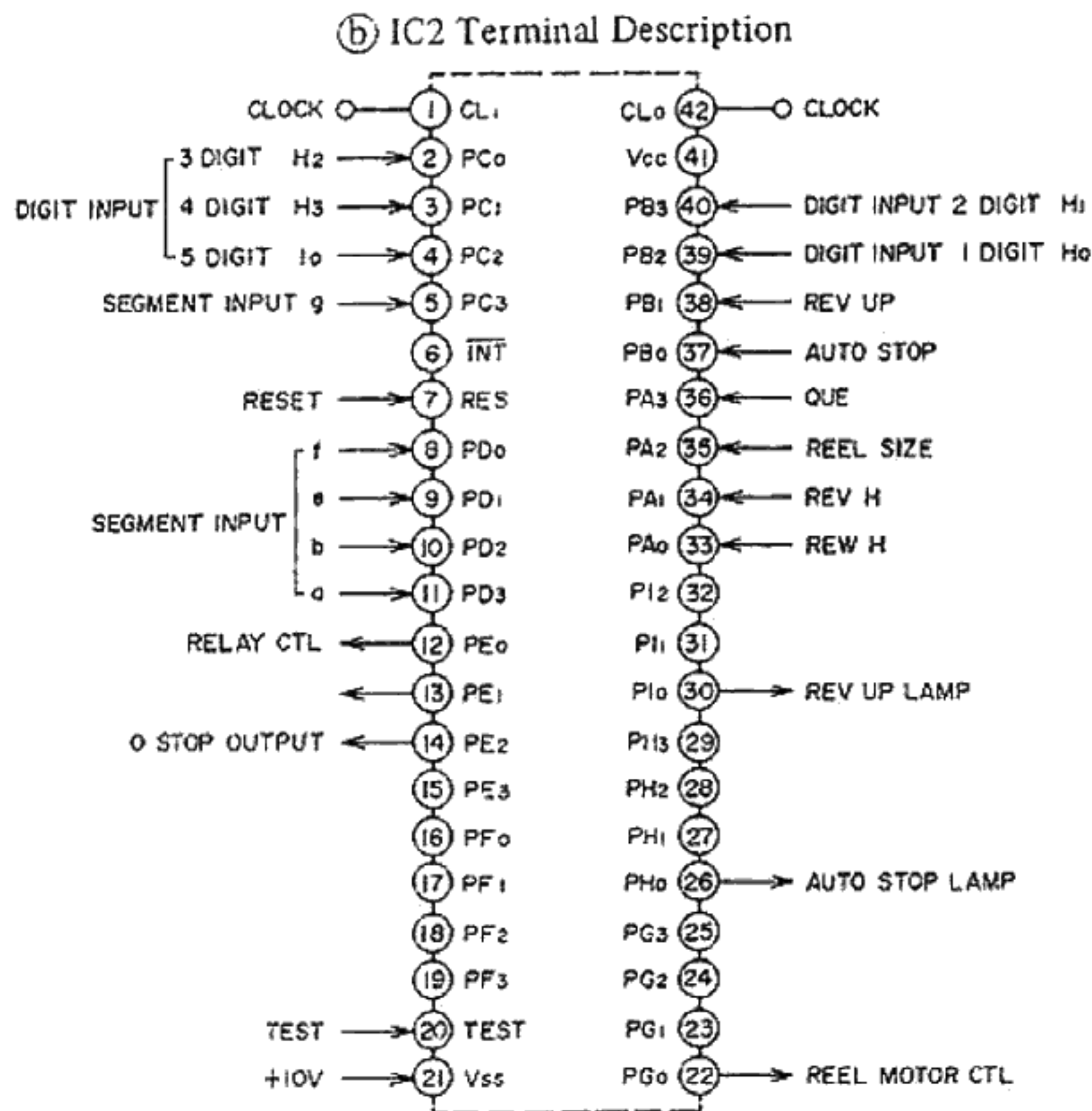

Fig. 13

© Function Mode Selector Circuit

Selection of the function mode is controlled by the pulse timing using a microcomputer. For easier understanding, one input terminal (35) will be explained as an example. The terminal (35) receives four signals, i. e., the strobe signals from (26), (27), (28) and (29). Each pulse signal from (26), (27), (28) and (29) has a different timing. Assuming that the signals from these terminals are 1000, 0100, 0010 and 0001, signal 1000 of Terminal (26) will pass D84, and through the collector of TR85, it will enter the emitter of TR60. If FWD (SW3) button is pressed, the base of TR60 is earthed through R202, TR60 is energized, and Signal 1000 will be outputted into Terminal (35) of IC1 through D60.

If any input is made into (35), it is processed within the microcomputer depending on the signal and the signal is outputted from the respective terminal. If 1000 is inputted into (35), it is judged as FWD and the related signal is inputted to the output terminal. (See Fig. 14). Similarly, Signal 0100 from (27) passes the emitter and collector of TR86 and enters the Counter P.C Board. When the program SW (SW6) is pressed, Signal 0100 is inputted into IC1 (35). Signal 0010 from (28) passes the collector/emitter of TR87, and through D66 and the reverse selector SW (), it is inputted into IC1 (35). Signal 0001 from (29) passes SR1 and SW906 and is inputted into (35).

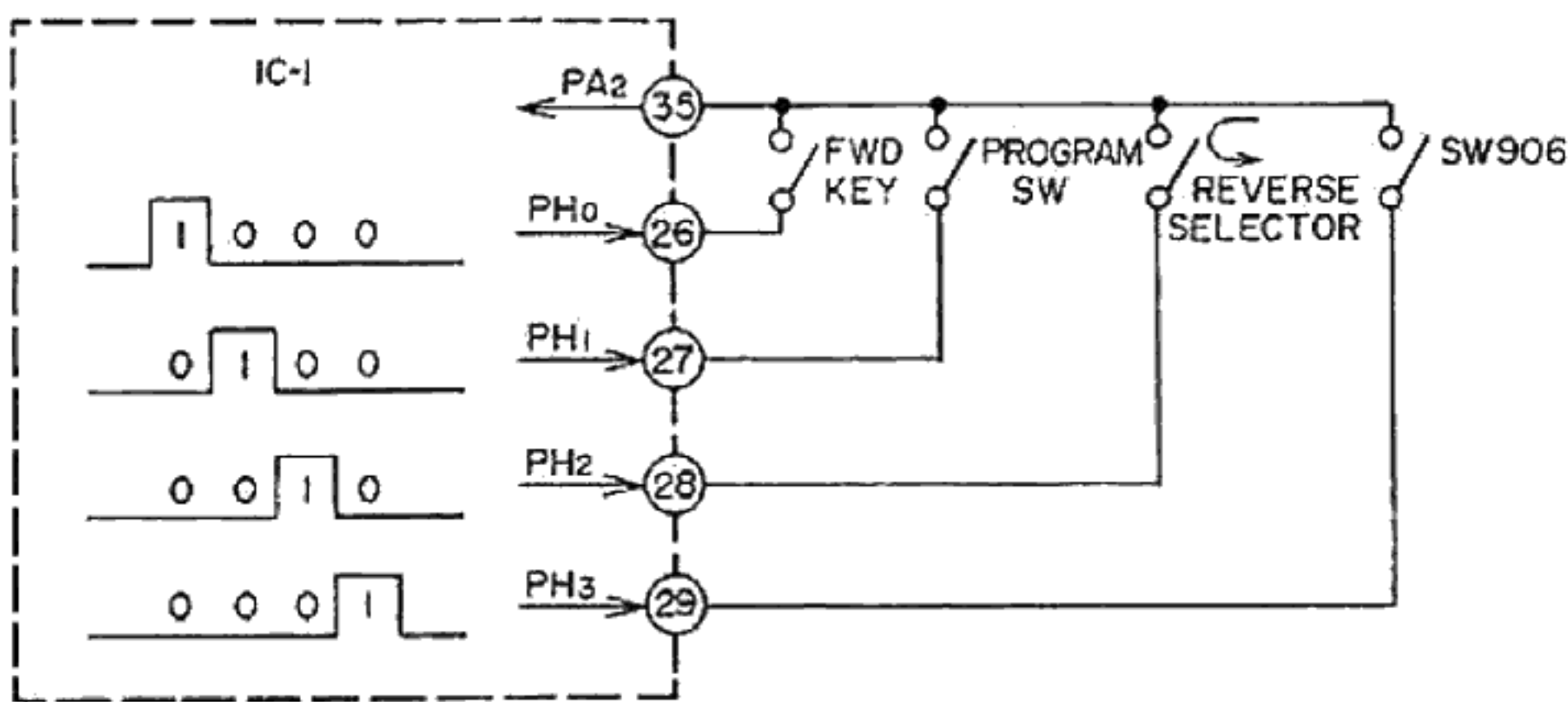

Fig. 14

Input to (35)	Judgement and Output by Microcomputer
1000	Output H to Terminals (12), (14), (24) and (25) of IC1 (FWD output order).
0100	Act as clear/program SW only when MEMORY AUTO REV SW is ON.
0010	Act once as a reverse equipment.
0001	(SW 906 is ON and tension arm is locked) When FWD, REV, FF or RWD key is pressed, process the other signals after making Terminal (18) H.

Fig. 15

Fig. 16 shows the truth table when the function switches are pressed.

Function SW Terminal	FF	FWD	STOP	REV	REW	PAUSE	REC	REC MUTE	REC PAUSE
12	H	H	H	H	H	H	L	H	H
13	L	L	L	L	L	L	H	H	H
14	H	H	L	H	H	L	H	L	L
15	H	L	H	L	H	L	L	L	L
16	L	L	L	H	L	L	L	L	L
17	L	H	L	H	L	H	H	H	H
24	H	L	L	L	H	L	L	L	L
25	H	H	L	H	L	L	H	H	L

Note: H of Terminal (14):
H of other Terminals:

Fig. 16

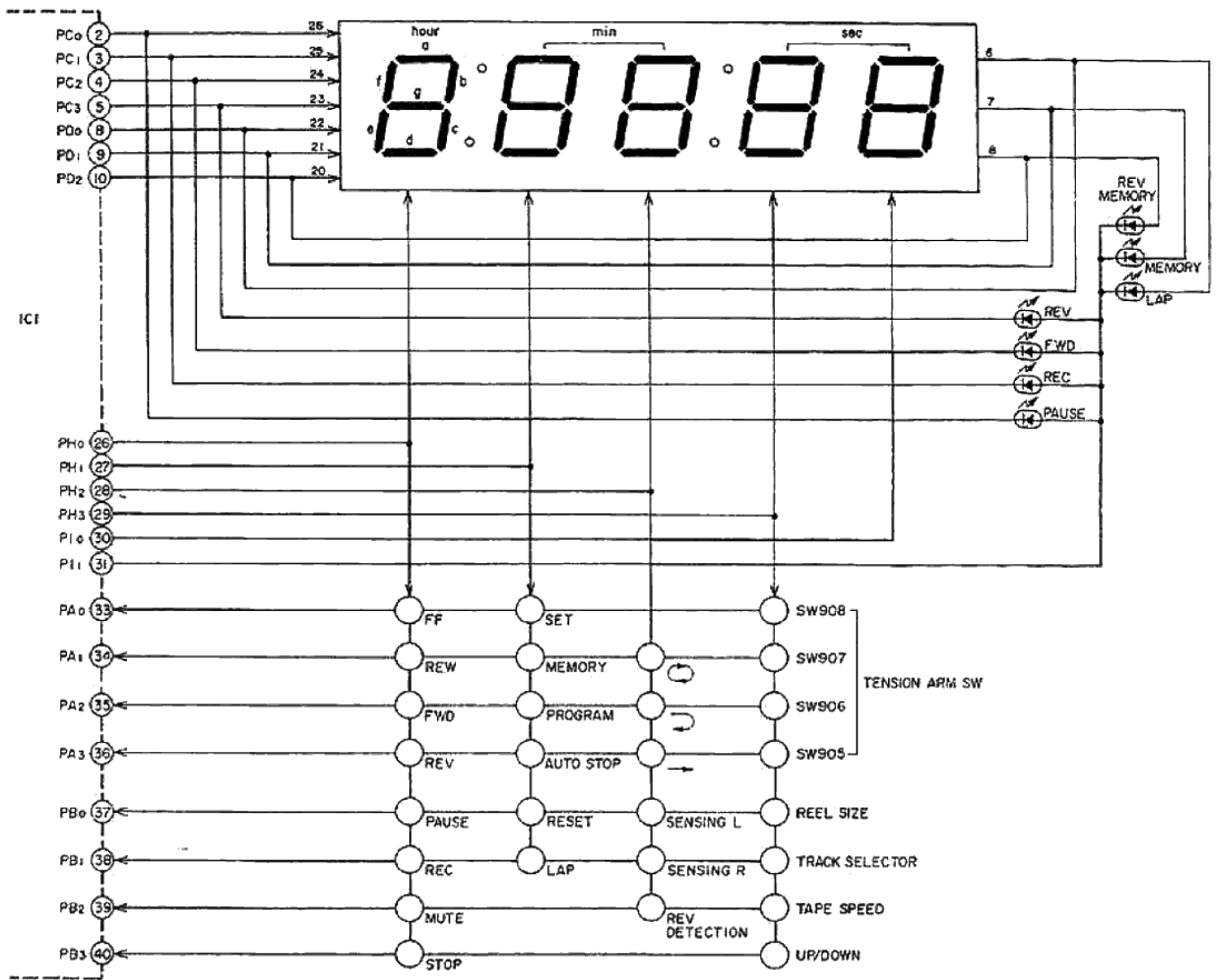



Fig. 17

Description of mode switches in Fig. 17

Mode	Description of switches
FF	Operation P.C Board SW1 Remocon TR58
RWD	Operation P.C Board SW2 Remocon TR59
FWD	Operation P.C Board SW3 Remocon TR60
REV	Operation P.C Board SW4 Remocon TR61
Pause	Operation P.C Board SW5 Remocon TR62
REC	Operation P.C Board SW6 Remocon TR63
Mute	Operation P.C Board SW7 Remocon TR64
Stop	Operation P.C Board SW8 Remocon TR65
Set	Counter P.C Board SW5
Memory	Counter P.C Board SW1
Program	Counter P.C Board SW6
Automatic Stop	Counter P.C Board SW7
Reset	Counter P.C Board SW8
Lap	Counter P.C Board SW2
Permanent REV	SW P.C Board SW1 
One Time REV	SW P.C Board SW1 

MON REV	SW P.C Board SW1
Sensing L	Sensing Pole L
Sensing R	Sensing Pole R
REV detection	RL6
SW908	Take up side tension arm, detection of shut-off position
SW907	Take up side tension arm, detection of arm lock position
SW906	Supply side tension arm, shut-off position
SW905	Supply side tension arm, arm lock position
Reel size	SW903
Track selector	Pre Amp SW3
Tape Speed	Tape Speed SW
UP/DOWN	Counter P.C Board SW3

④ Tension Arm Locking System

(Refer to Figs. 18 to 21)

The tension arm position is detected by means of the microswitch. At the time of shut-off, the tension arm is placed in locked position by the release motor. If any function key (FWD, REV,

FF or RWD) is pressed when the tension arm is in the lock position, the release motor starts and after the arm comes to its middle position (i. e., the tape is loaded), such outputs as listed in Fig. 16 will be issued from the terminals of IC1.

Truth table of BA6109 (IC 5, 6)

IN (5) Pin	IN (6) Pin	V Out 1 (2) Pin	V Out 2 (10) Pin
H	H	L	L
L	H	L	H
H	L	H	L
L	L	Open	Open

Fig. 18

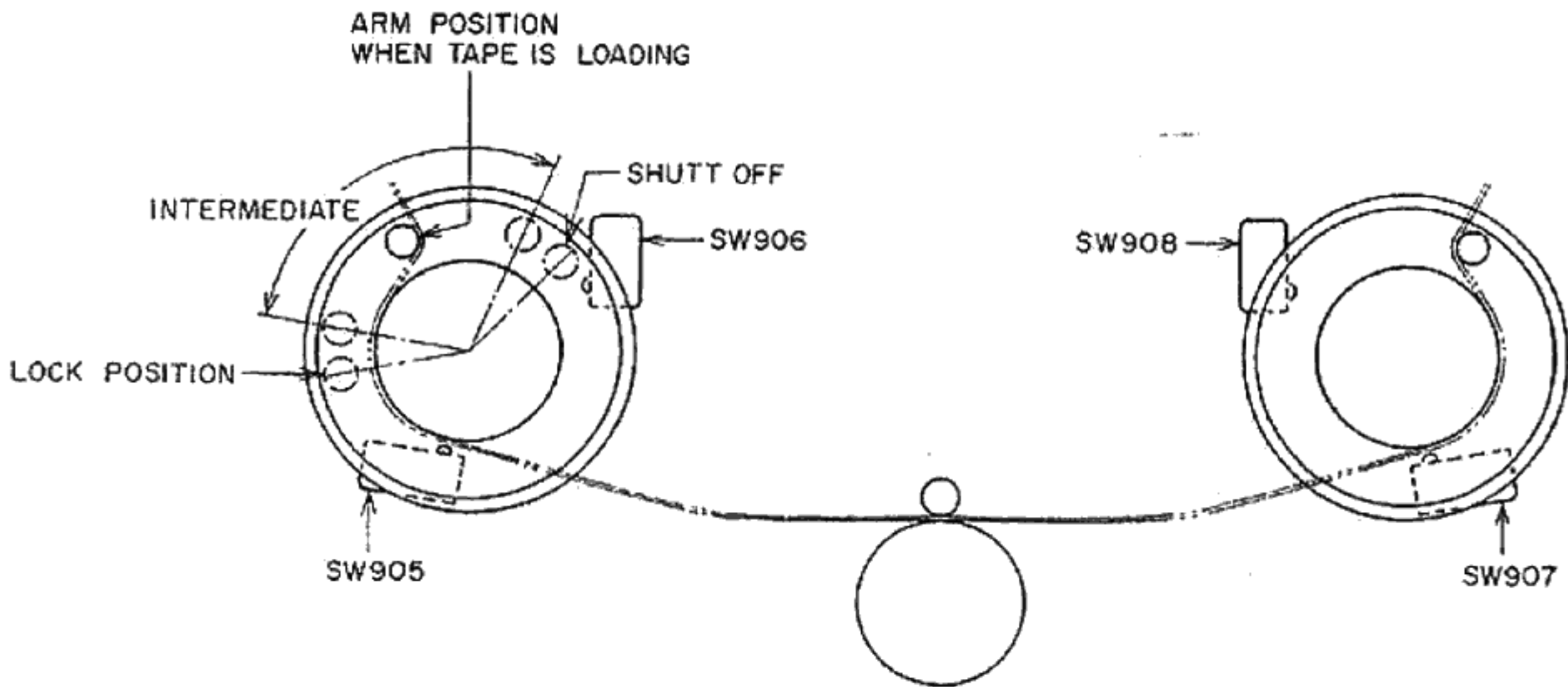

Fig. 19

SW positions in accordance with the tension arm positions

Position of tension arm	SW905	SW906	SW907	SW908
Lock	off	ON	off	ON
Middle	ON	off	ON	off
Shut-off	off	off	off	off

Fig. 20

Truth table of IC1 Pins (18) and (19) in accordance with tension arm positions

(18) Pin	(19) Pin	
L	L	Lock
H	L	↓ Play key is pressed
L	L	Middle
L	H	↓ Shut-off
L	L	Lock

Fig. 21

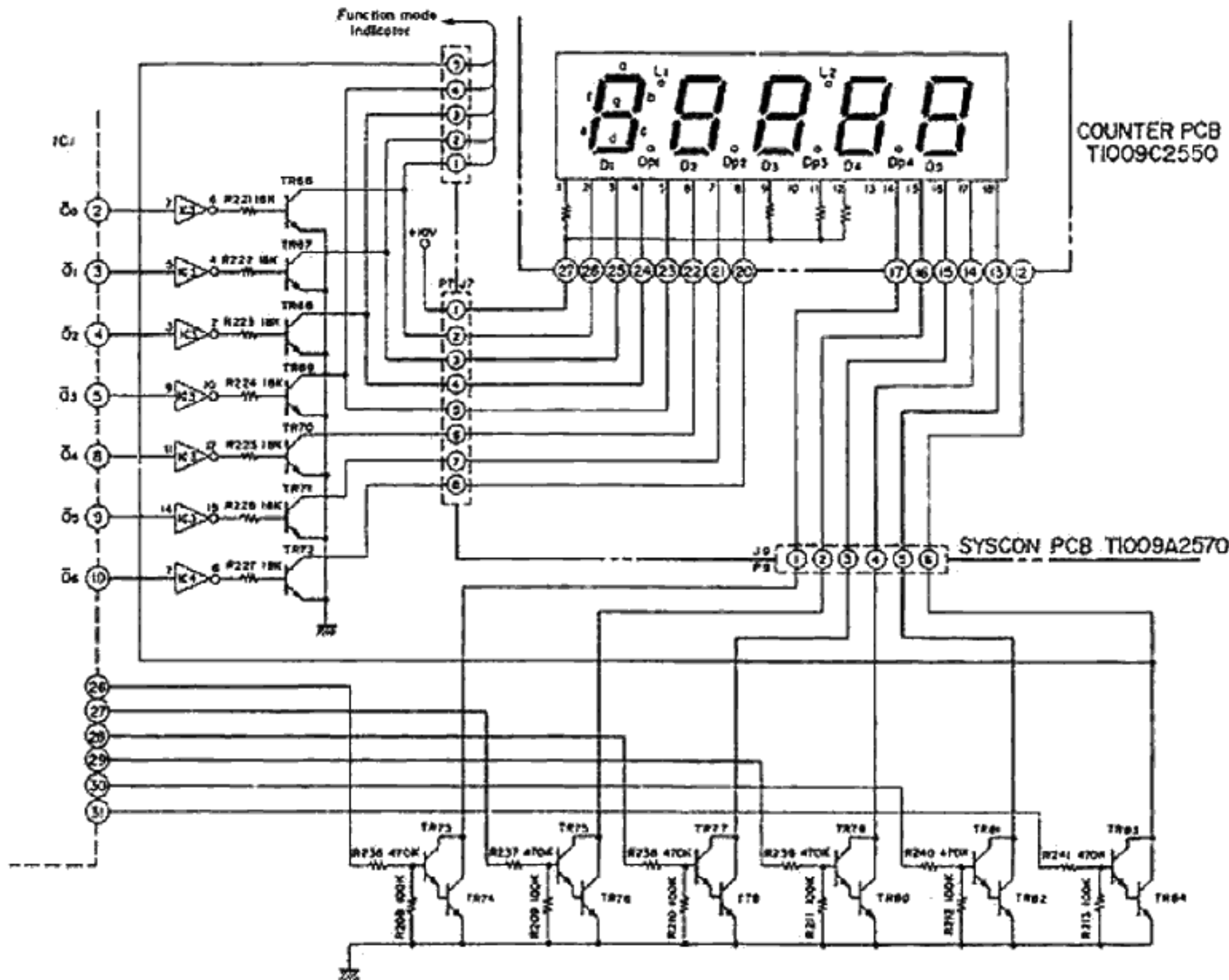

Fig. 22

④ Function Mode Indicator Circuit and Counter Circuit

● Function Mode Indicator Circuit

The function mode indicator lighting is also controlled by the operation timing of the control signal from the microcomputer.

Here we will explain about the situation in Fig. 23 (FWD PLAY/PAUSE) as one example. Hereinafter FWD PLAY is just written as PLAY. Under PLAY/PAUSE, PAUSE of the function mode indicator is always lit and PLAY is flashing. Firstly, refer to the vertical row of the function mode indicators of O0 - O3 in Fig. 23. You will note that PAUSE IND has "H" level, PLAY IND has "L/H" flashing and others have "L" level.

The signals of (O0 - O3) and IC (31) enter IC3 and IC4 and TR83 in Fig. 22. In this way the digits of the function mode ind. and PLAY/PAUSE IND. are inputted. When these two digits are synchronized, the indicator is lit.

● Counter Indicator Circuit

The counter indicators are also lit by the pulse from the microcomputer, and it is not that all the indicators are always lit.

Because of the afterimage, it appears to our eyes that all the digits are lit despite the fact that they are lit in sequence as shown in Fig. 24. This system is called dynamic lighting system.

Fig. 23 shows the timing chart. By means of the waveforms of IC (26) - (30) coming from the microcomputer, the lighting position of LED of each digit is moved in sequence. Take the example of the first digit.

The first digit can only be lit when the waveform of IC (30) is "H" level. Depending on the condition of O0 - O6 at the time of "H" level, each segment is lit and the figure is indicated. Since the segments of the LED indicators are cathode common, each segment is lit when O0 - O6 are at "H" level. If we see the condi-

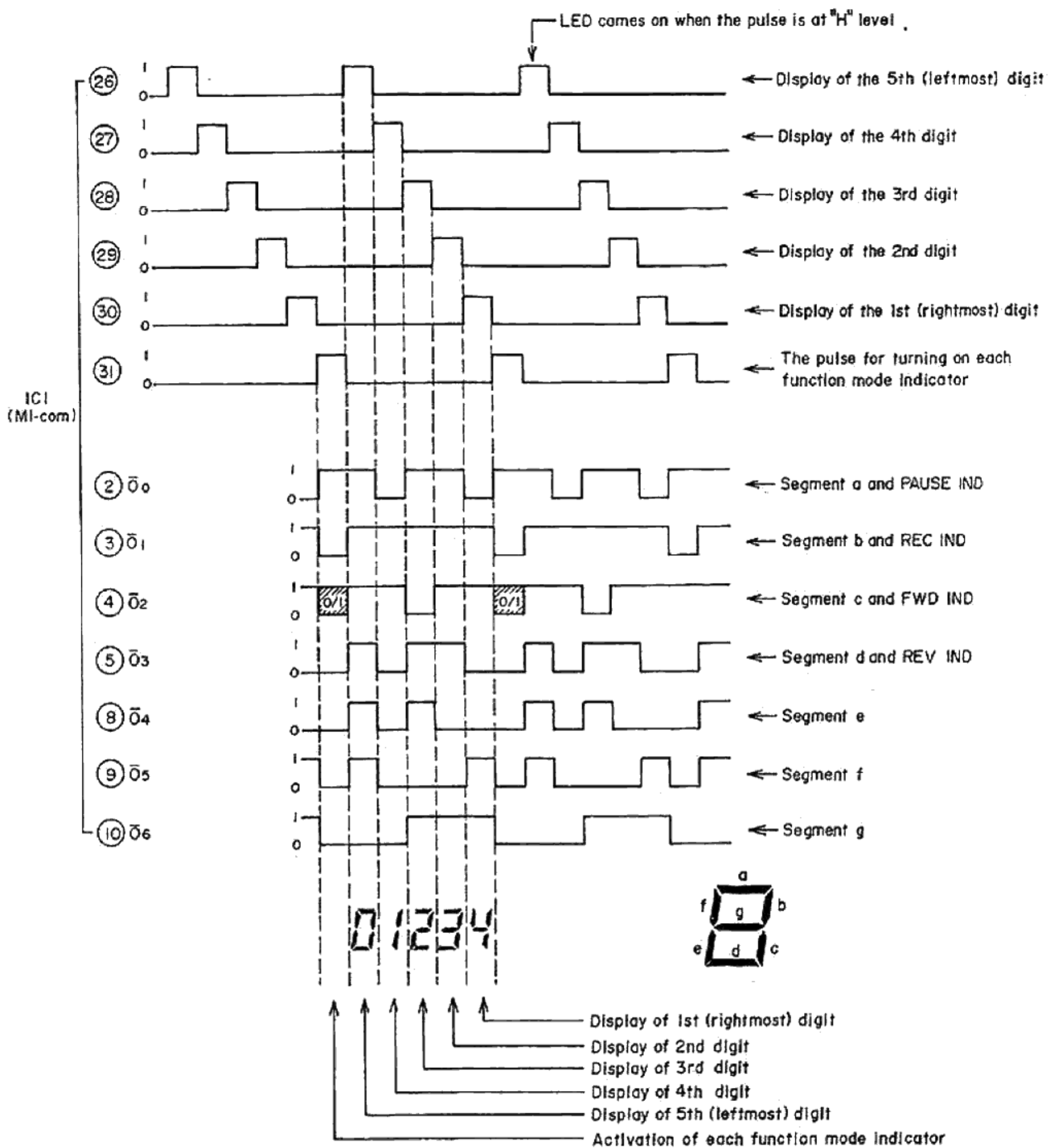

Fig. 23



Fig. 24

tion of $\bar{O}_0 - \bar{O}_6$ of the first digit indication in Fig. 23, b, c, f, and g segments are lit and a, d and e segments are dark. In this condition, the indicator indicates 4. Similarly if we look at the 2nd - 5th digits, 01234 is indicated in the condition of Fig. 23.

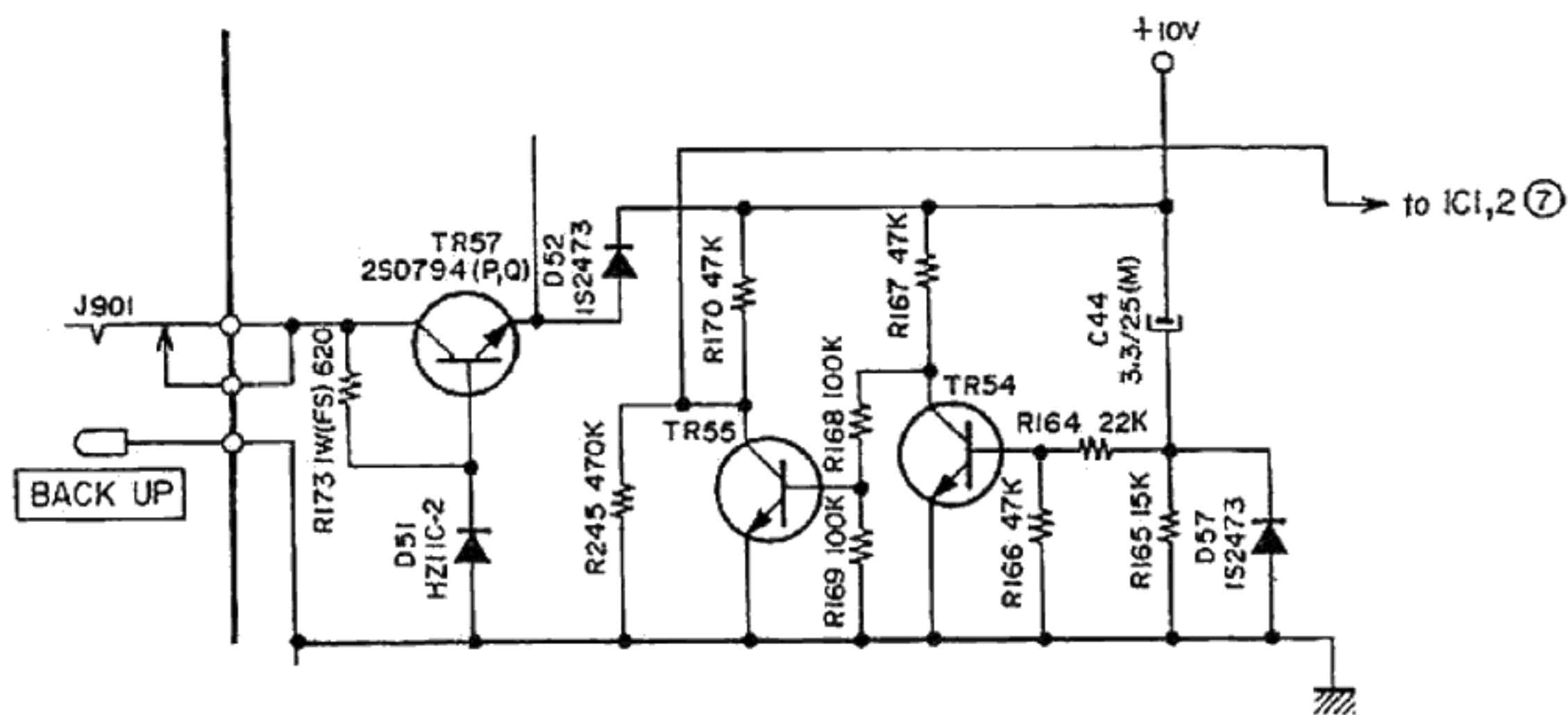

Fig. 25

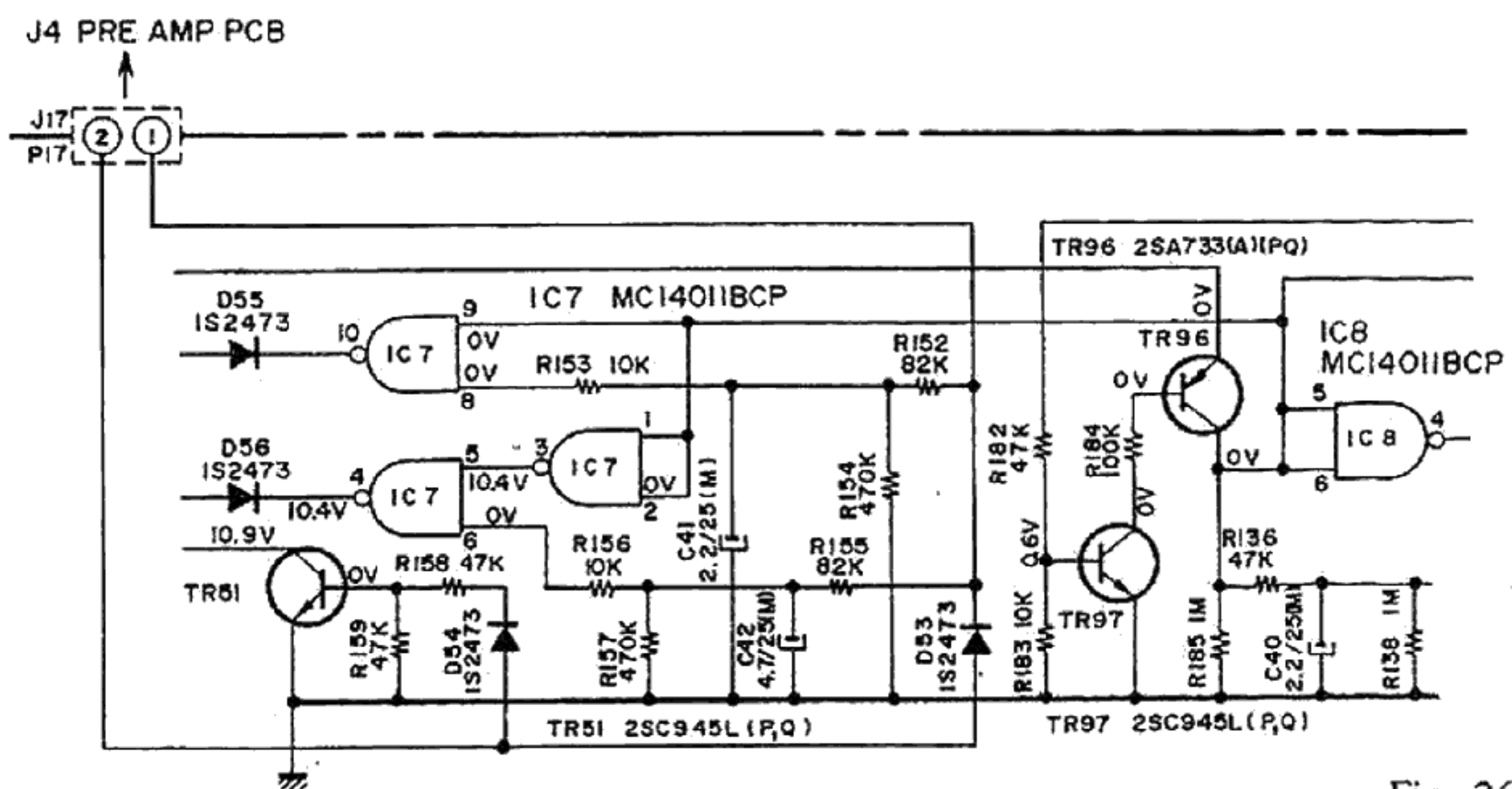

Fig. 26

Ⓕ Microcomputer Resetting Circuit

(Refer to Fig. 25)

A reset circuit is provided in order to eliminate the memory of the electronic counter and 0 Stop when power is supplied.

When power is turned on, the voltage (+10V) is supplied to the base of TR54 through C44 and R164 to turn TR54 ON, i. e., the collector of TR54 will be "L" to turn TR55 OFF through R168 which means the collector of TR55 will be "H". Then "H" is supplied to Terminal 7 of IC1 and 2, and when Terminal 7 becomes "H", the microcomputer is reset. When the charging to C44 is completed, TR54 is turned OFF, TR55 ON and Terminal 7 "L".

Ⓖ Timer Starting Circuit (Refer to Fig. 26)

When TIMER REC:

When power is switched ON, the base of TR51 is turned "H" through C49 and R88 of the Pre

Amplifier P.C Board and through D54 and R158 of J17 2 of the Syscon P.C Board. The collector becomes "L" to turn TR63 ON through R205. The "H" from J17 2 makes IC7 6 "H" through D53, R155 and R156, and at the same time, "H" is supplied to IC7 8 through D53, R152 and R153. Depending on the condition of the collector of TR96, the output to IC7 10 or IC7 4 is determined and the direction of FWD or REV is determined. If the collector of TR96 is "L", IC7 3 becomes "H".

Therefore, "H" goes into IC7 5 and 6, the IC7 4 becomes "L".

TR60 is energized through D56, i. e., FWD REC.

When TIMER PB:

Same as for REC TIMER START, but due to the lack of input in TR51, FWD or REV PB is achieved instead of REC.

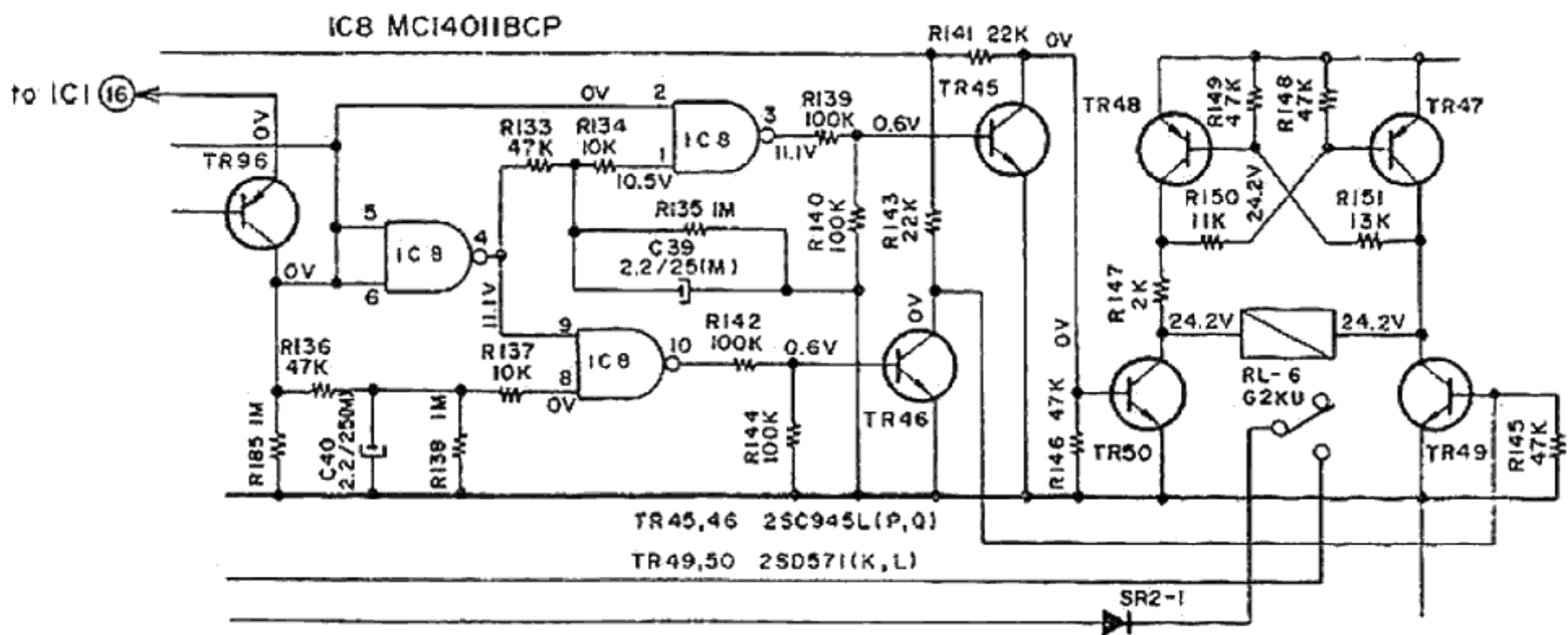

Fig. 27

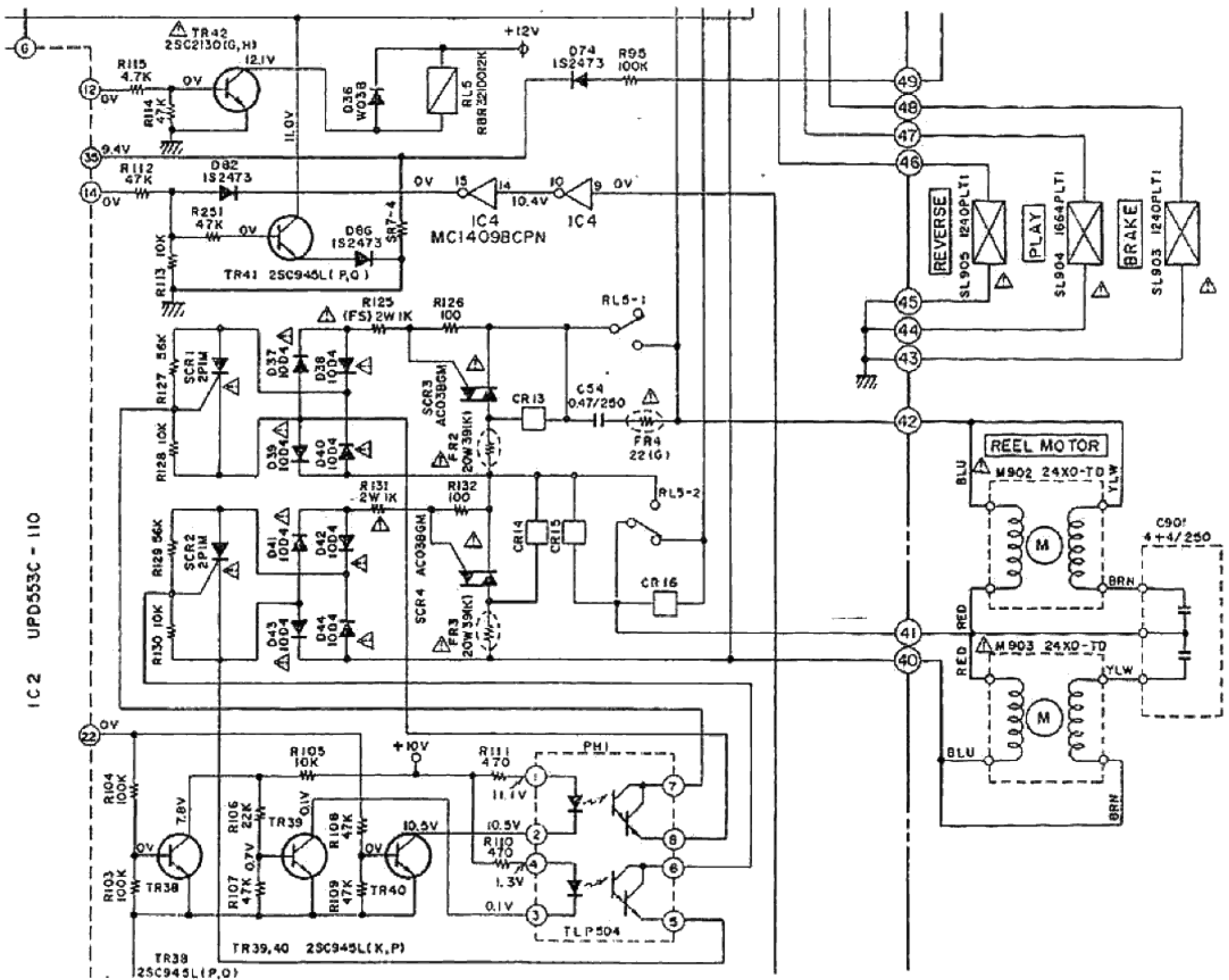

Fig. 28

(h) Reverse Holding Circuit (Refer to Fig. 27)
 Suppose the REV key is pressed when the machine is in FWD mode. IC1 (16) becomes "H", and "H" is supplied to the emitter of TR96. Because the base of TR96 is always "L", the "H" of the emitter of TR96 will go to the collector of TR96. IC8 (5) and (6) be-

come "H", IC8 (4) "L", and the "H" of TR96 collector is supplied to IC8 (8) through R136 and R137, and therefore, "H" to IC8 (10). This "H" is supplied to the base of TR46 through R142 to make the collector of TR46 "L". Consequently the base of TR49 is "L" and the collector of TR49 "H". Since IC8 (4)

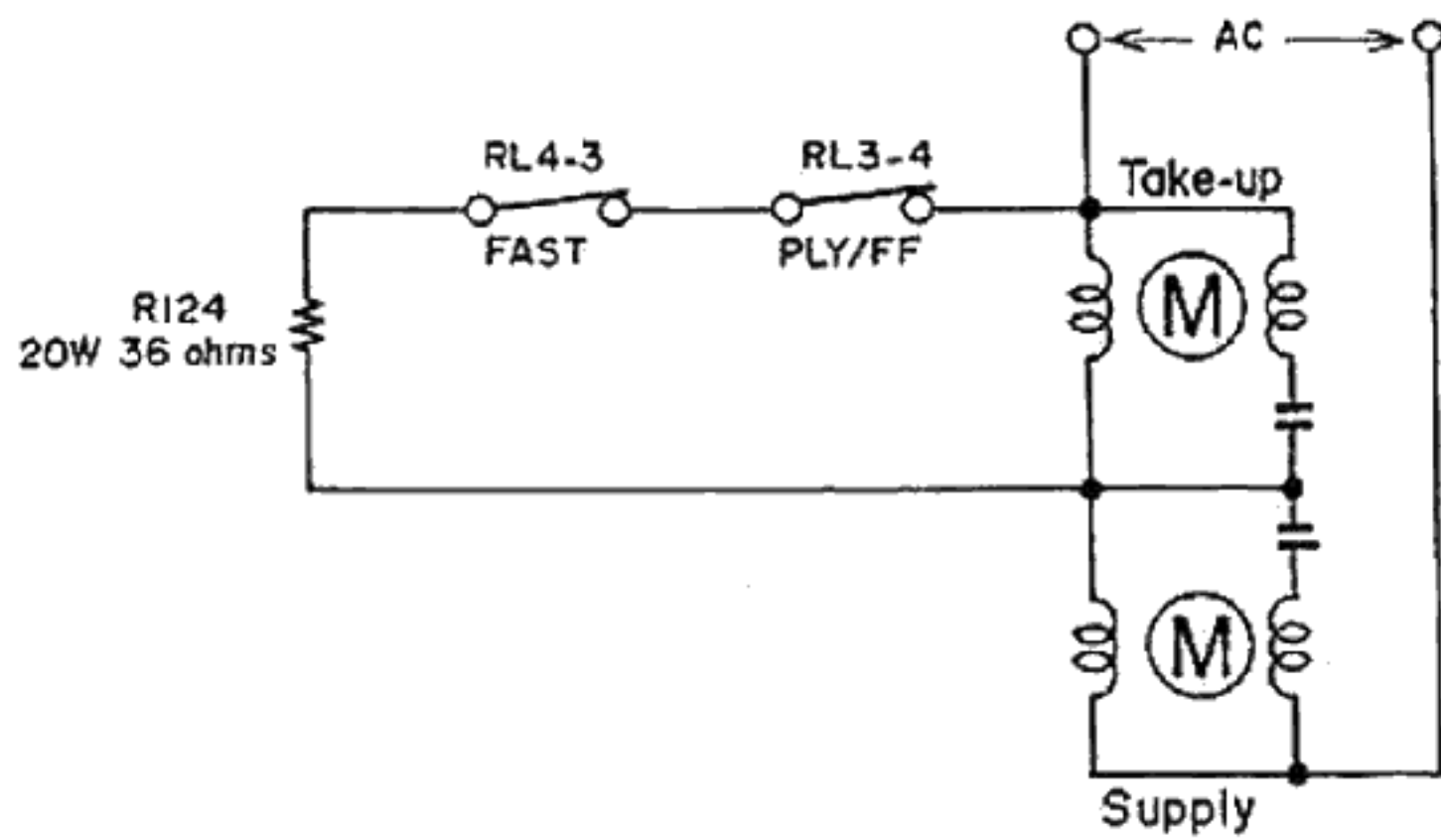

Fig. 29

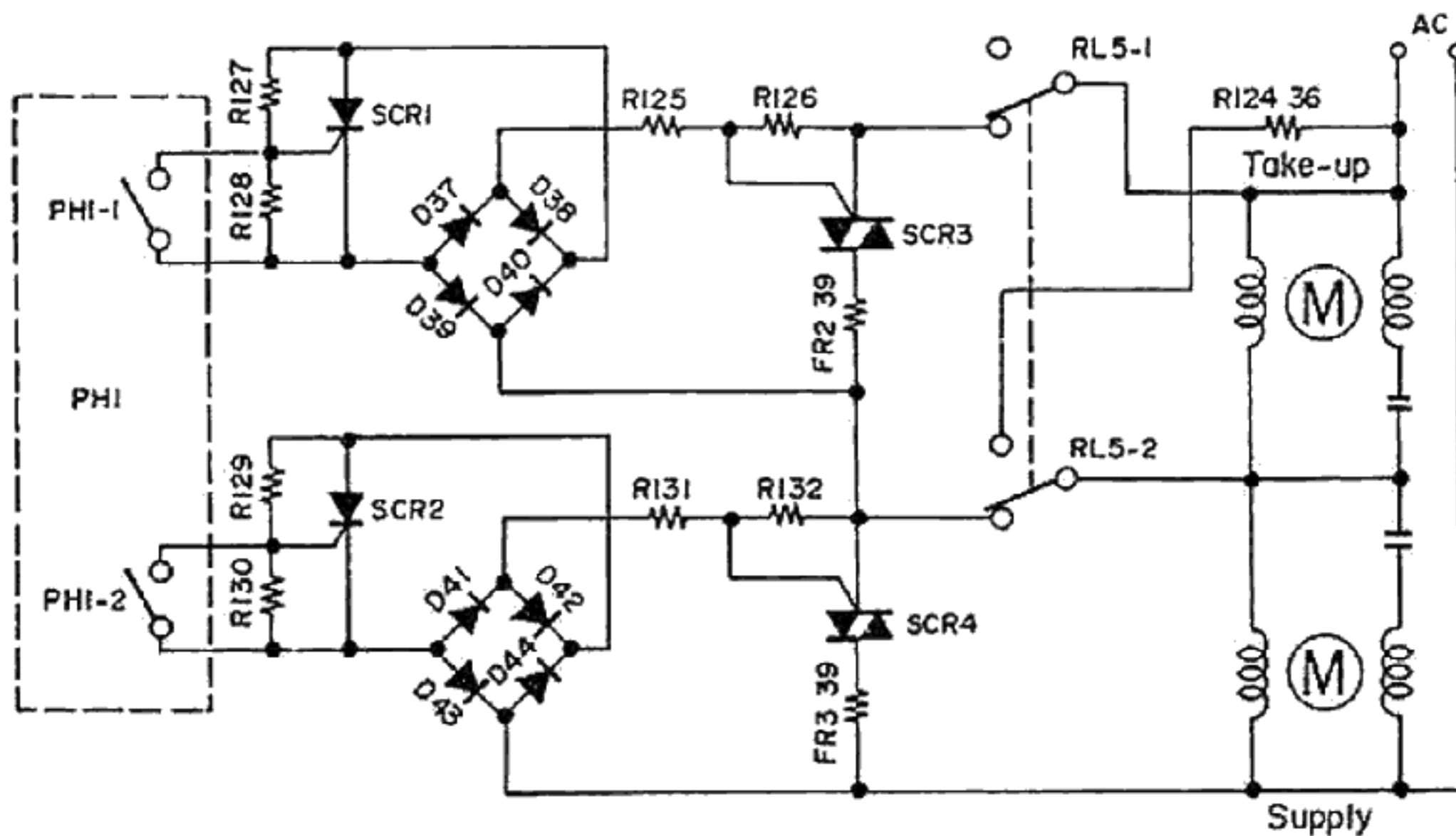

Fig. 30

is "H" in FWD mode, C39 is charged. Therefore, IC8 (1) is kept at "H" until C39 is discharged even if IC8 (4) becomes "L". Because IC8 (1) and (2) become "H", IC8 (3) "L". The base of TR45 becomes "L" through R139 and the collector "H", and TR50 is energized. "L" of the collector of TR50 turns TR47 ON through R147 and R150. Therefore, current runs to RL6 and TR50 through TR47, and RL6 is working. The RL6 relay worked remains in that position even when the power is turned OFF, and when the reverse voltage is applied, it is reset. When the TR6 is worked, the output from IC1 (28) is taken into IC1 (39) through the switch of RL6 and the direction is decided for REV mode by the microcomputer.

(i) Brake Control System of Reel Motor

(Refer to Figs. 28 to 32)

In the mode (Reel Size 7", 0 Stop SW ON), RWD SW is turned ON from a certain counter number, for example, 0:05:00.

Fig. 29 shows how the take up reel motor and the supply reel motor work. Since R124 36 ohms is connected in parallel to the take up reel motor, the torque of the supply reel motor is increased, and the tape is wound by the supply reel motor. If the counter indicates 0:00:50 from this position, "H" signal is issued from IC2 (12) (relay control).

"H" enters the base of TR42 through R115 to turn TR42 ON and RL5 ON. Fig. 30 shows the condition when RL5 is ON. R124 36 ohms so far attached is disconnected from the take up reel motor. Suppose the signal of IC2 (22) (reel motor control) is in "L". TR40 is OFF via R108, and TR38 is turned OFF via R104. TR38 collector will be "H". The base of TR49 will be "H" through R106 to turn TR39 ON, i. e., the switch of PH1-2 is ON.

Therefore, PH1-1 will be ON when PH1-2 is OFF or vice versa.

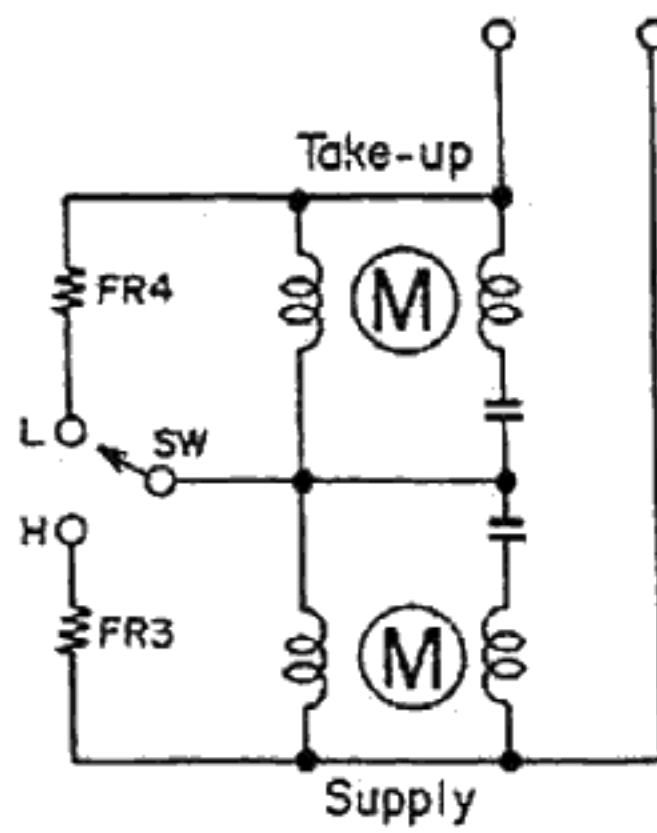

Fig. 31

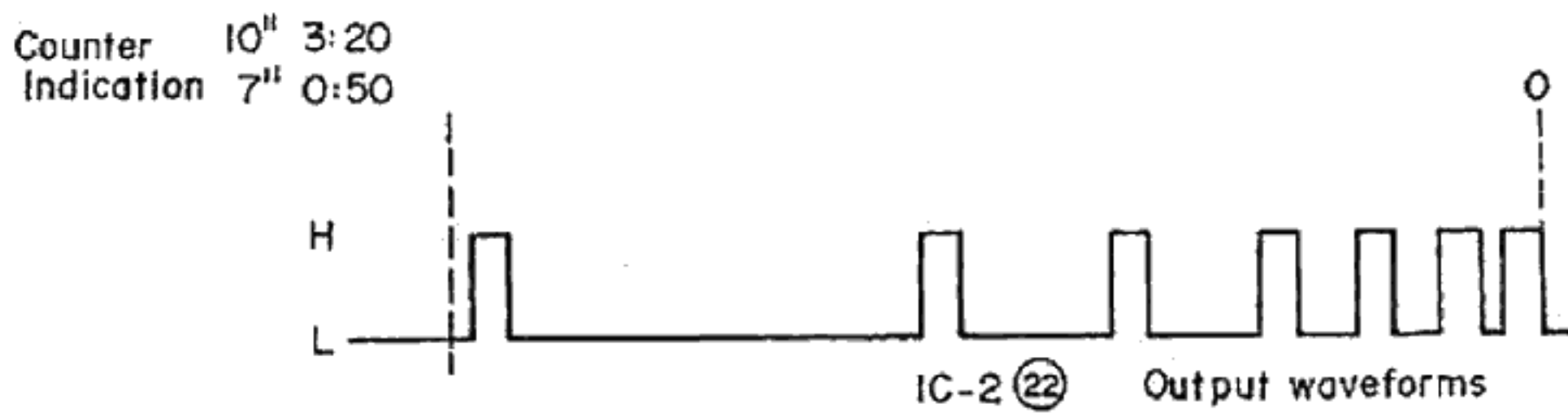

Fig. 32

When the switch of PH1-2 is ON, the gate of SCR2 becomes "L" and SCR2 is turned OFF. When SCR2 is OFF, no current will run to R132 and there will be no potential difference between the gate and the anode of SCR4 (triode AC switch), and therefore it will be OFF. On the other hand, since PH1-1 is OFF, SCR1 will be ON and SCR3 ON. This means that FR2 39 ohms, instead of R124 36 ohms, is connected in parallel to the take up reel motor and the RWD mode is maintained. Now, the signal of IC2 (22) is considered. IC2 (6) (interrupt) receives the signal (input to real time counter) from the Detector P.C Board. The counter starts counting the input signal of (6) every 25 msec from 0:00:50. This data is compared with the data written in IC2 and when the reel motor is running at a speed faster than the data, "H" signal is issued to (22). The switch in Fig. 31 goes to H side, the mode similar to FF is achieved and apparently the brake is applied.

Such waveform as shown in Fig. 32 appears at IC2 (22).

In such a way, the brake is applied on the motor to ensure that the motor stops at 0:00:00 of the counter. In the case of reel size 10", the microcomputer start working at the counter indication of 0:03:20. With the 0 Stop when the COUNT UP SW is ON, IC2 (22) usually becomes "H", and the negative pulse is issued.

VII. MECHANISM ADJUSTMENT

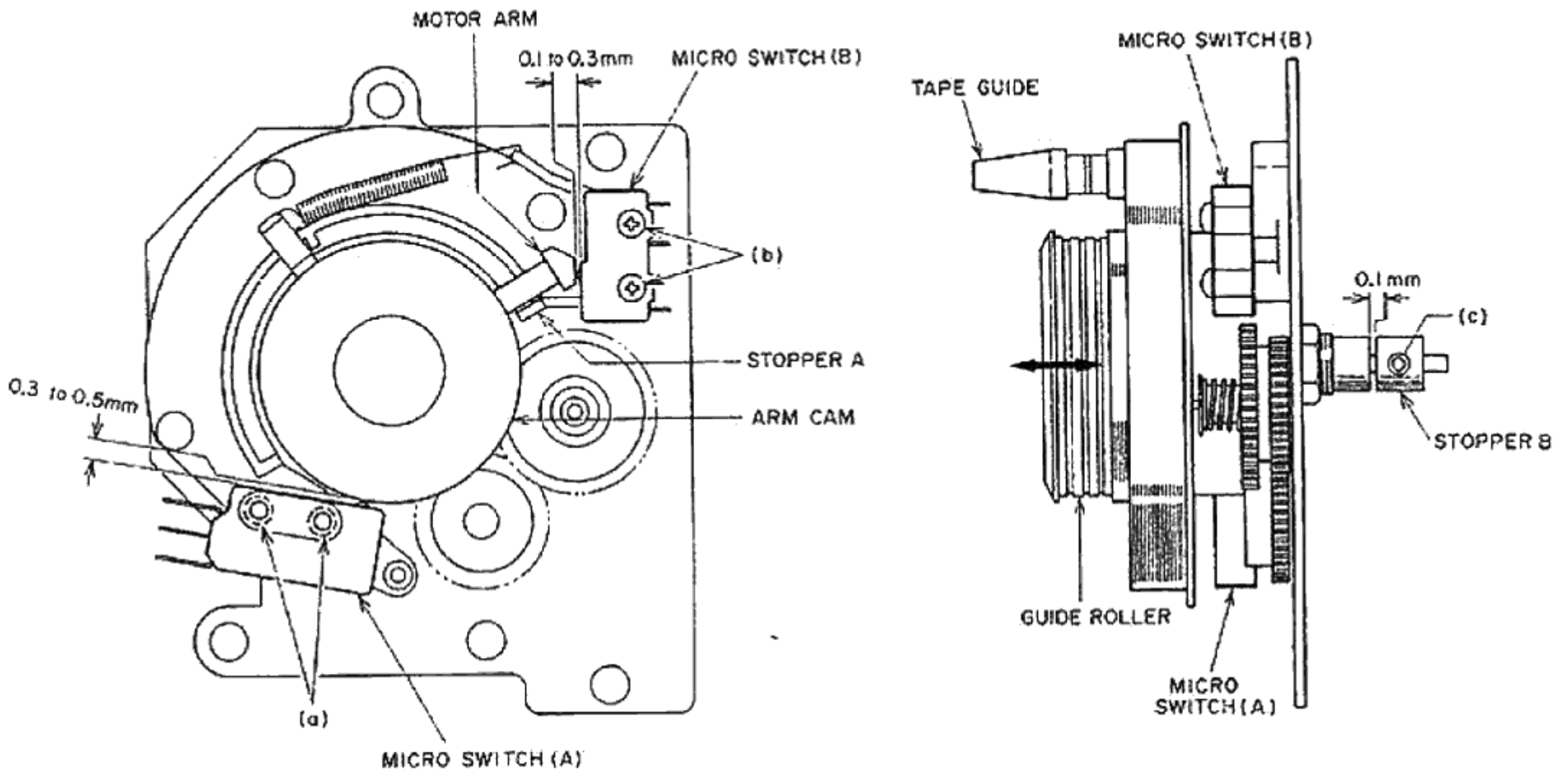

Fig. 33 Roller Block

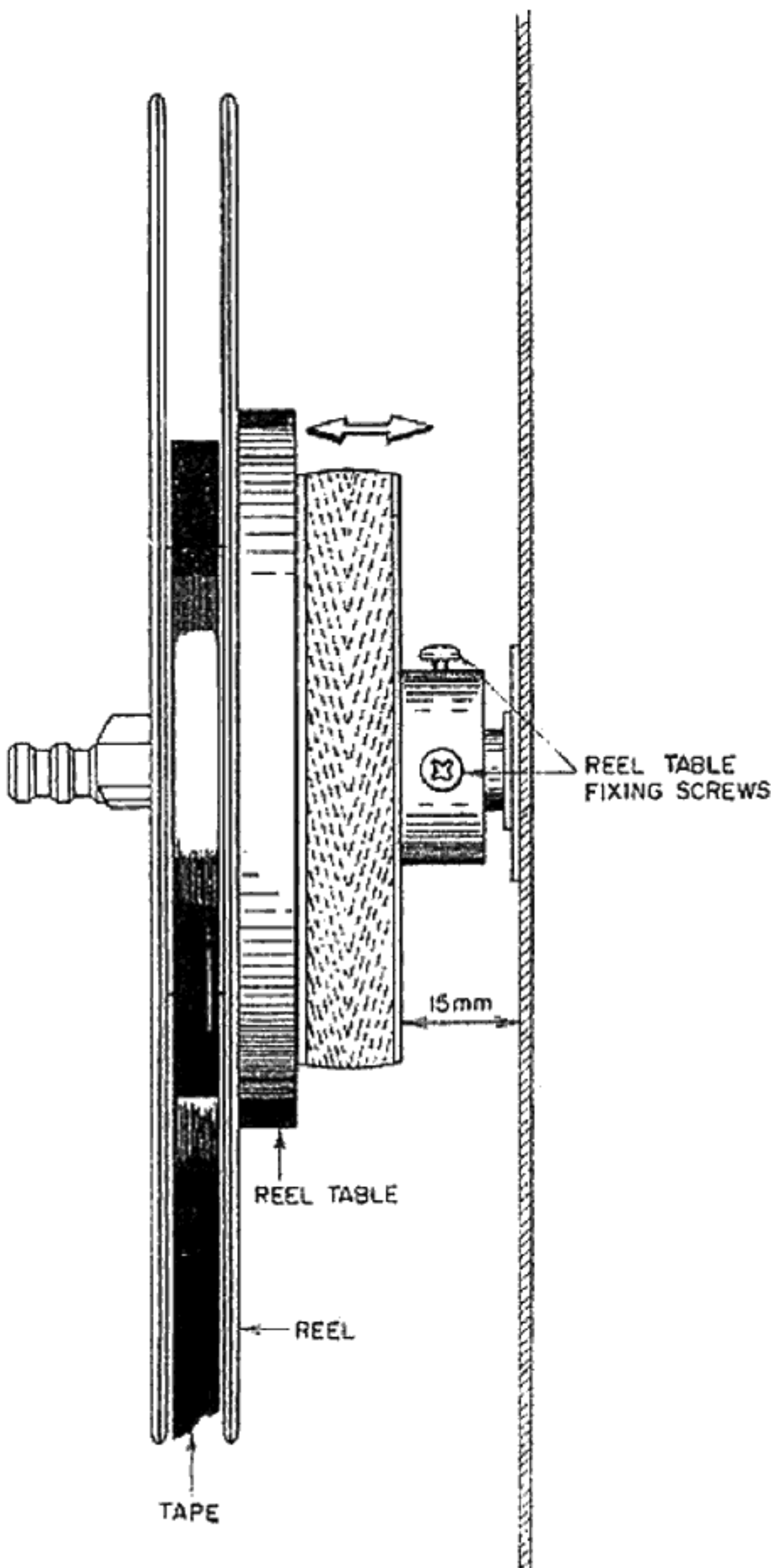

Fig. 34

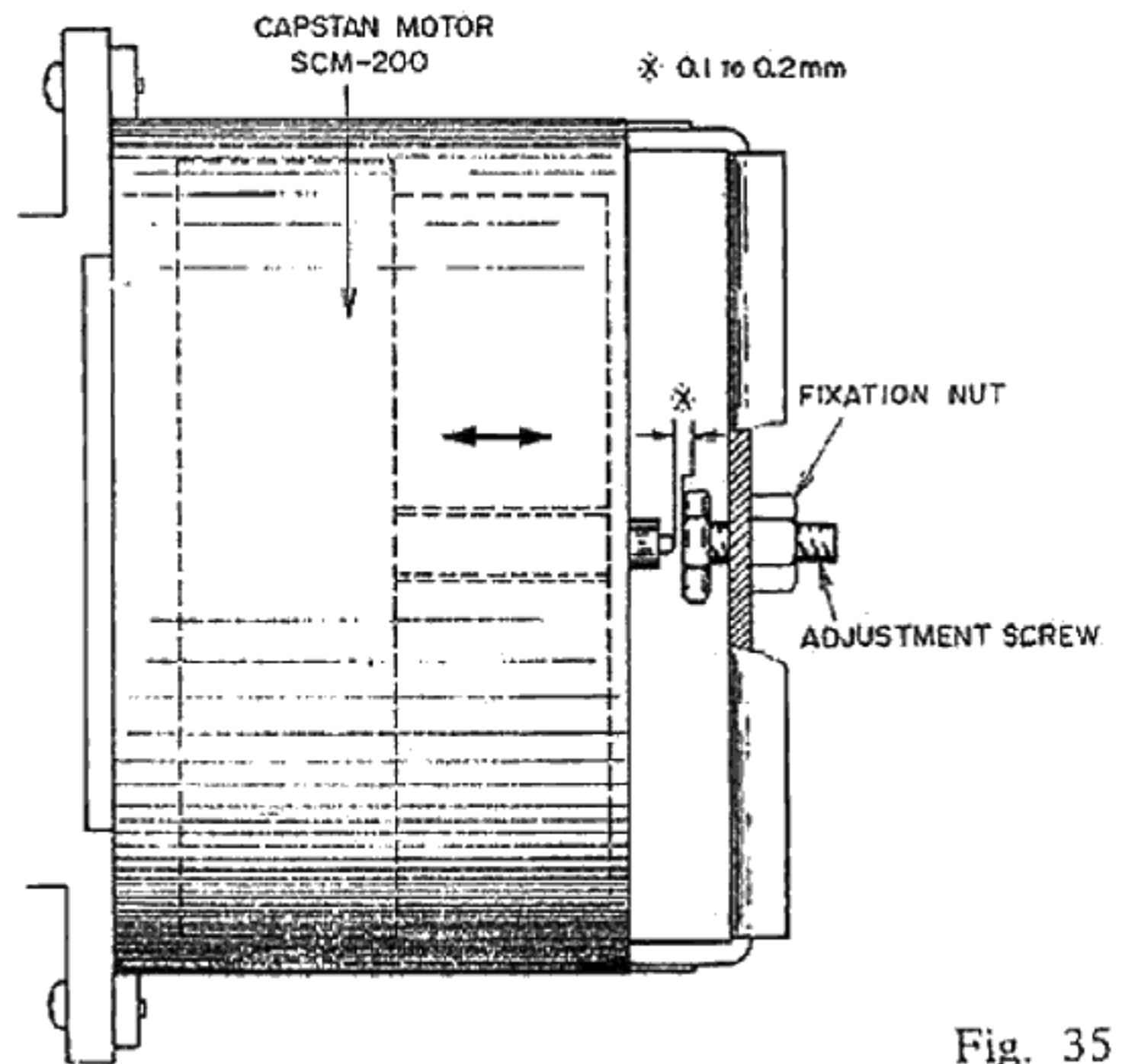

Fig. 35

1. GUIDE ROLLER LOOSE PLAY

ADJUSTMENT (Refer to Fig. 33)

Adjust the stopper B (roller pulley on the right) screw (c) so that the loose play gap is approximately 0.1 mm when the guide roller is moved as indicated by arrow mark in Fig. 33.

2. MICRO SWITCH POSITION ADJUSTMENT (Refer to Fig. 33)

1) Micro Switch (A) Position Adjustment

Adjust the screw (a) so that the gap between the arm cam and the micro switch is approximately 0.3 to 0.5 mm. Check that the micro switch works and that the arm lock smoothly disengages.

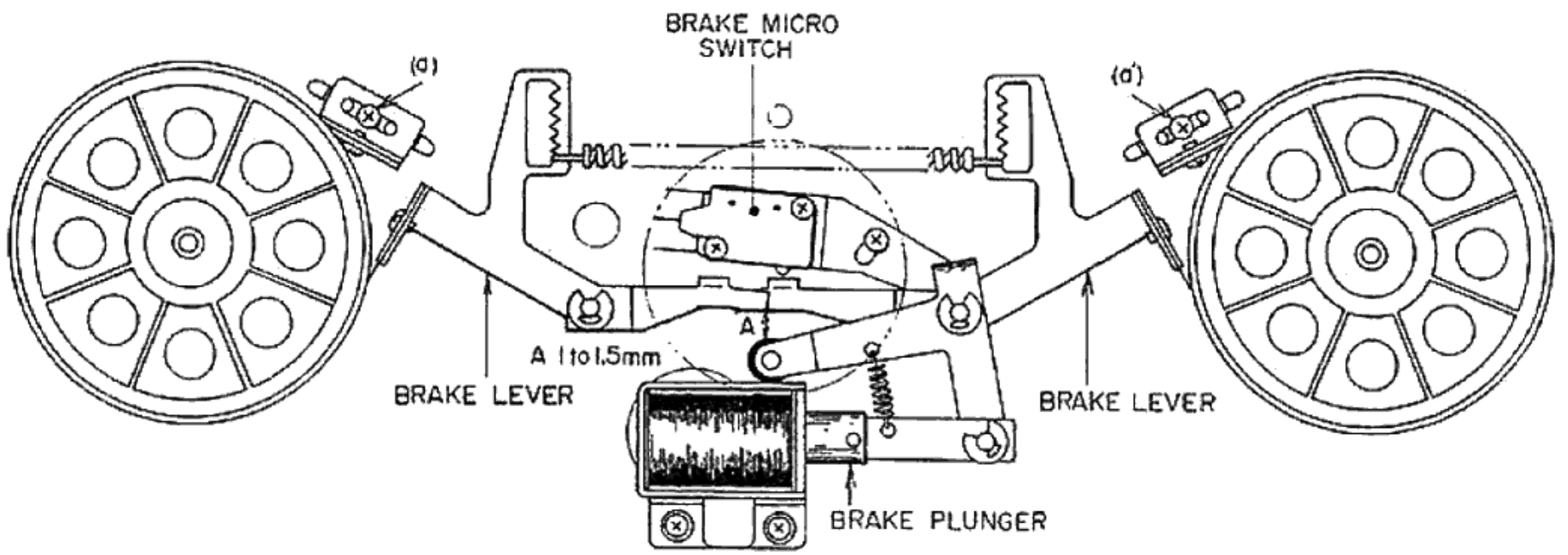

Fig. 36

2) Micro Switch (B) Position Adjustment

Rotate the arm cam, press the motor arm against the stopper A and then adjust so that the gap between the micro switch and the end of the motor arm is 0.1 to 0.3 mm.

NOTE: Steps 1 and 2 also apply to the right guide roller.

3. REEL TABLE HEIGHT ADJUSTMENT
(Refer to Fig. 34)

- 1) Temporarily screw in the fixing screws leaving a gap of 15 mm between the reel table and the chassis board.
- 2) Run the tape and adjust the height of the reel table so that the tape is taken up in the center of the reel. Tighten fixing screws. Adjust the height of the right reel table at fast forward, of the left reel table at rewind.

4. CAPSTAN SHAFT LOOSE PLAY
ADJUSTMENT (Refer to Fig. 35)

Adjust by turning Adjustment Screw to obtain a 0.1 to 0.2 mm degree of loose play when the capstan shaft is moved as indicated by the arrow mark. Tighten fixation nut to maintain optimum adjusted condition.

5. BRAKE BAND POSITION ADJUSTMENT
AND BRAKE TENSION ADJUSTMENT
(Refer to Figs. 36, 37, 38)

- 1) Adjust the screws (a) and (a') so that the gap A between the brake lever and the rubber is 1 to 1.5 mm.
- 2) Work the brake plunger to check that the brake band is not slanted.
- 3) With the machine stopped, adjust the position of the spring so that a brake tension of 560 ± 20 g is obtained on each brake.
- 4) By working the brake plunger with a finger, adjust the position of the micro switch screw (c) so that the gap between the brake lever and the micro switch body is 0.2 to 0.3 mm.

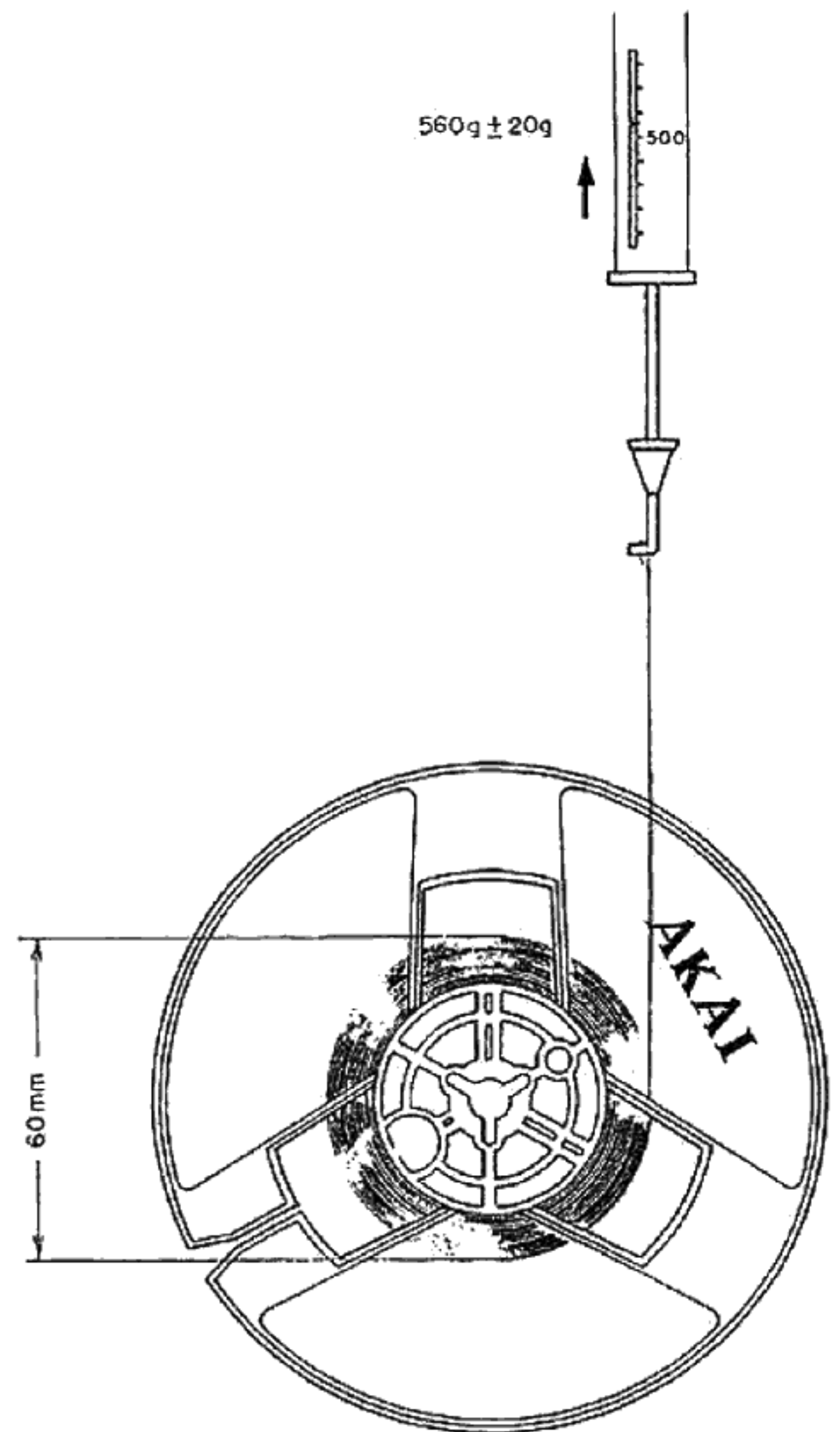

Fig. 37

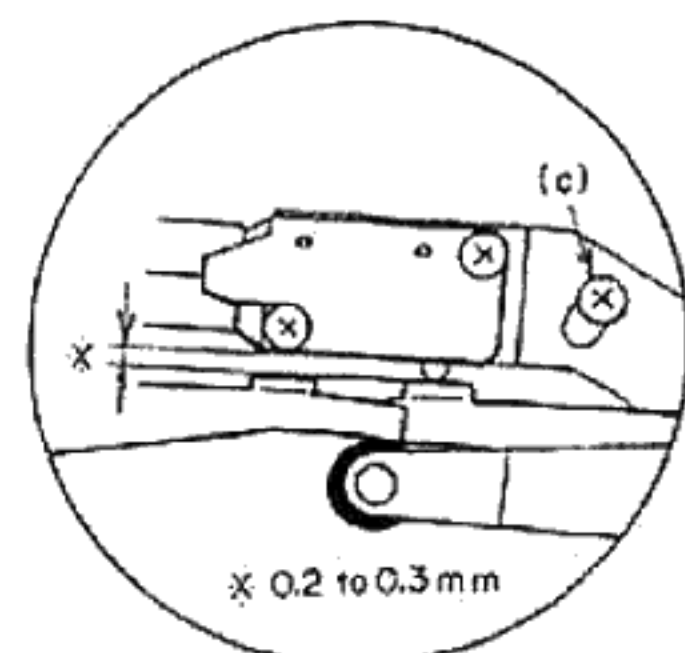

Fig. 38

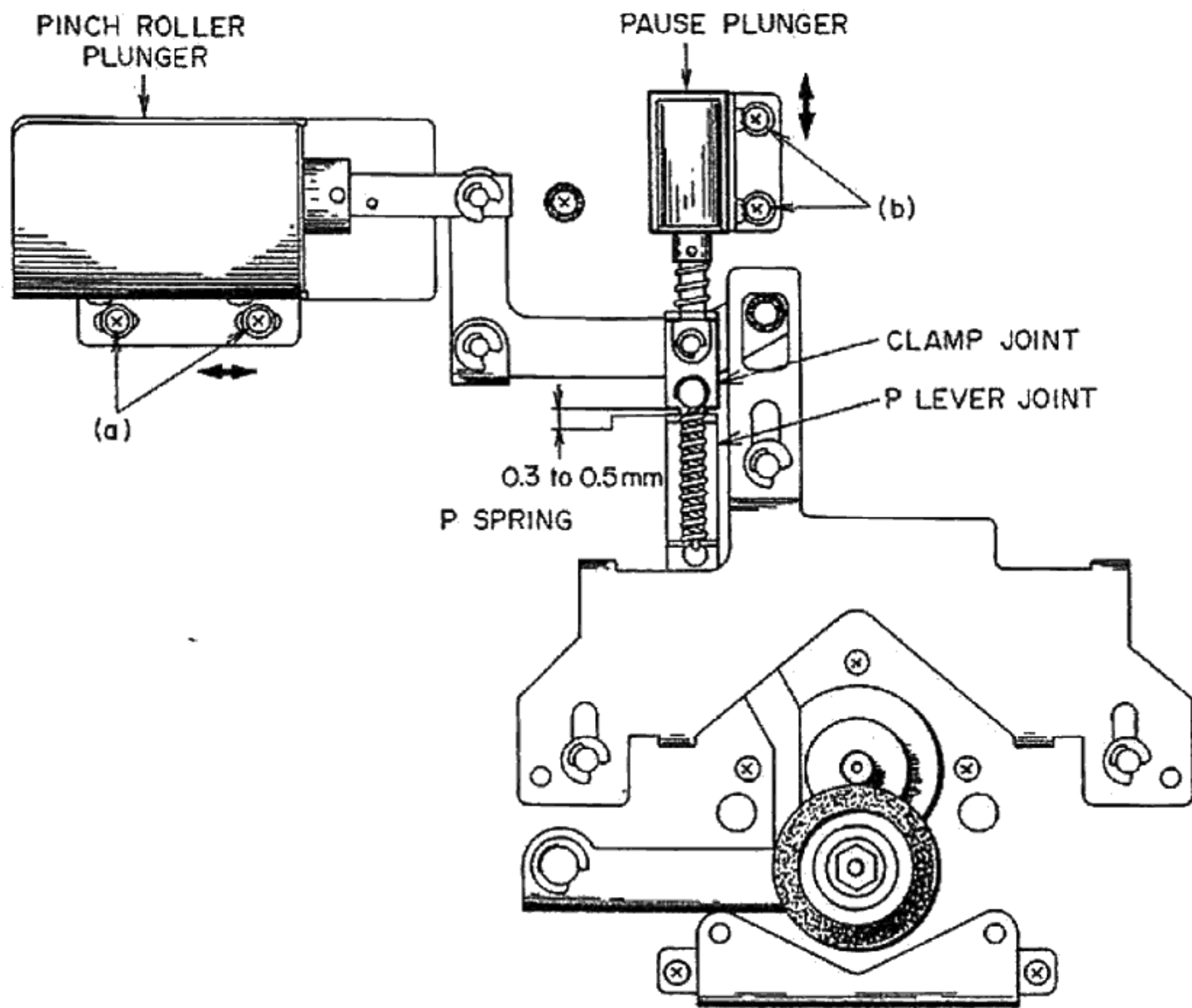

Fig. 39

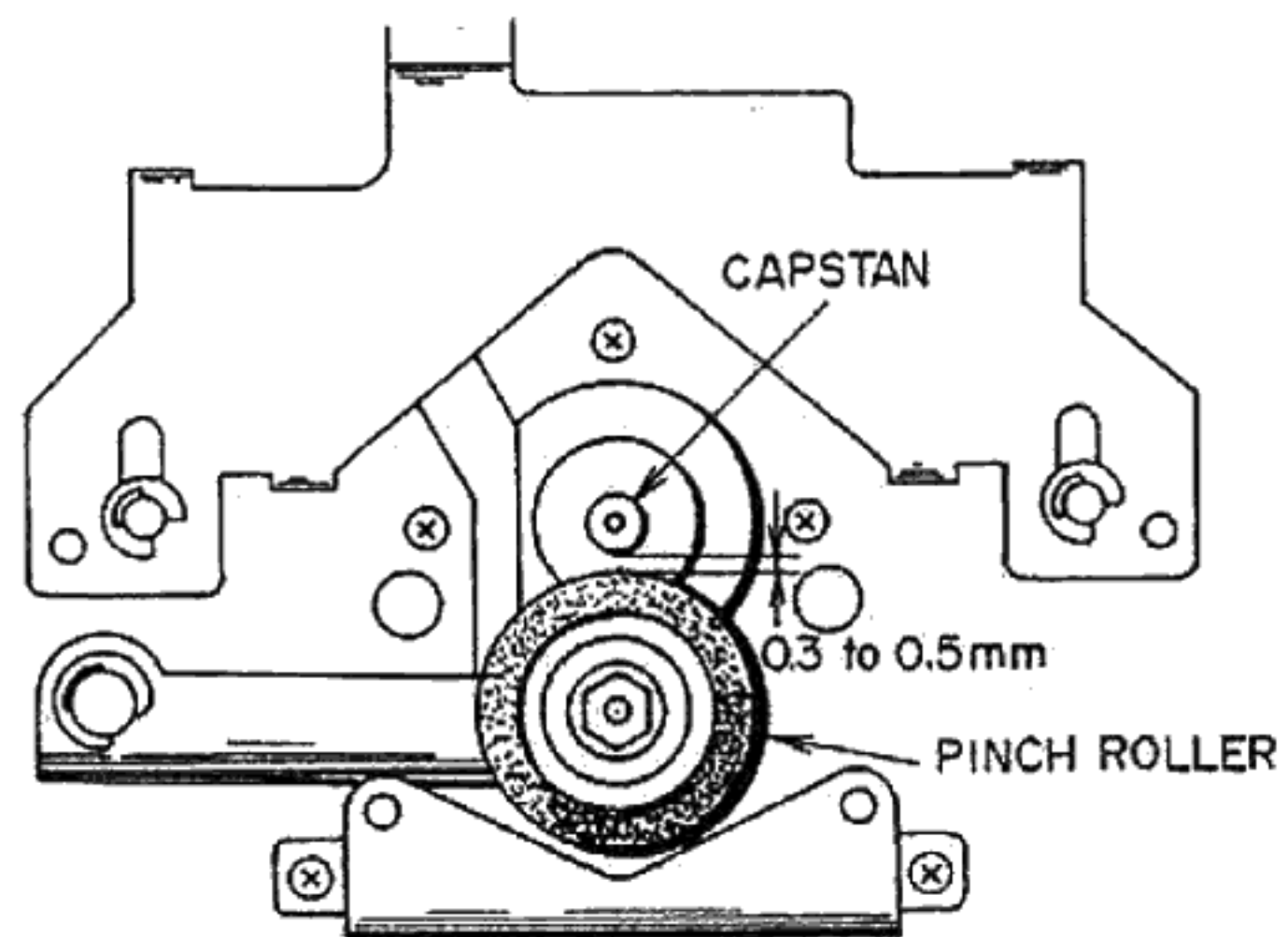

Fig. 40

6. PINCH ROLLER POSITION ADJUSTMENT (Refer to Fig. 39)

At the play mode, the gap between the clamp joint and the P lever joint should be 0.3 to 0.5 mm. Adjust the pinch roller plunger position with screws (a).

7. PAUSE PLUNGER POSITION ADJUSTMENT (Refer to Figs. 39, 40)

At the pause mode, the gap between the capstan and the pinch roller should be 0.3 to 0.5 mm. Adjust the pause plunger position with screws (b).

8. PINCH ROLLER PRESSURE ADJUSTMENT

Connect a 2 kg spring gauge to the pinch roller fixing screws. Pull down the pinch roller and then let it slowly move back. Check that the spring gauge reads 1.2 kg \pm 200 g at the moment the pinch roller touches the capstan and starts rolling.

If it reads otherwise, replace the P spring (See Fig. 40)

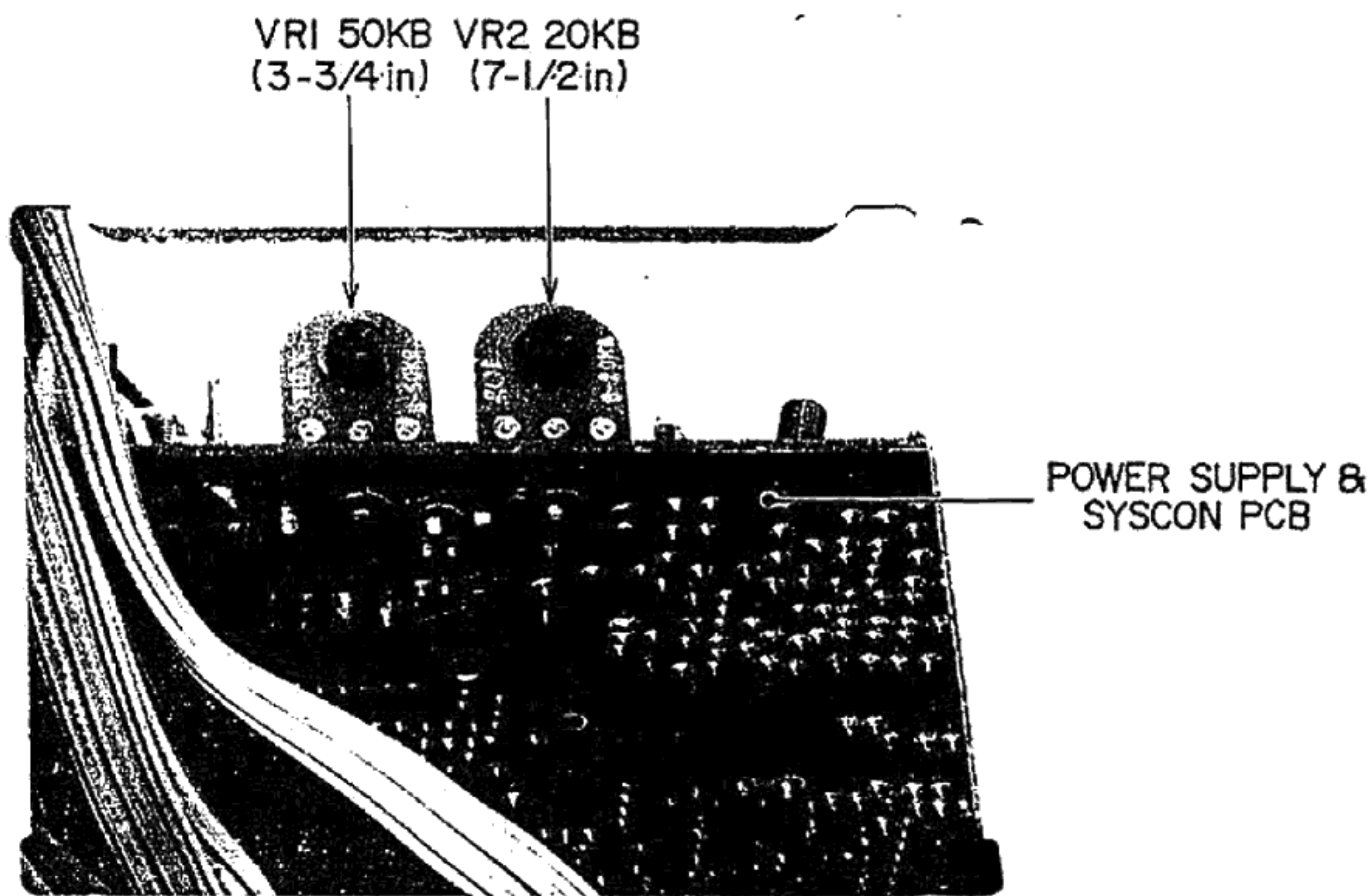

Fig. 41

9. TAPE SPEED ADJUSTMENT

(Refer to Fig. 41)

Set the Tape Speed Switch to 7-1/2 ips. and playback the 1,000 Hz, 7-1/2 Test Tape. Connect a frequency counter to LINE OUT and adjust VR2 20 kB until the counter reads, 1,000 Hz \pm 0.8%. Next, set the Tape Speed Switch to 3-3/4 ips. and adjust VR1 50 kB until the frequency counter reads 500 Hz \pm 1.0%.

VIII. HEAD ADJUSTMENT

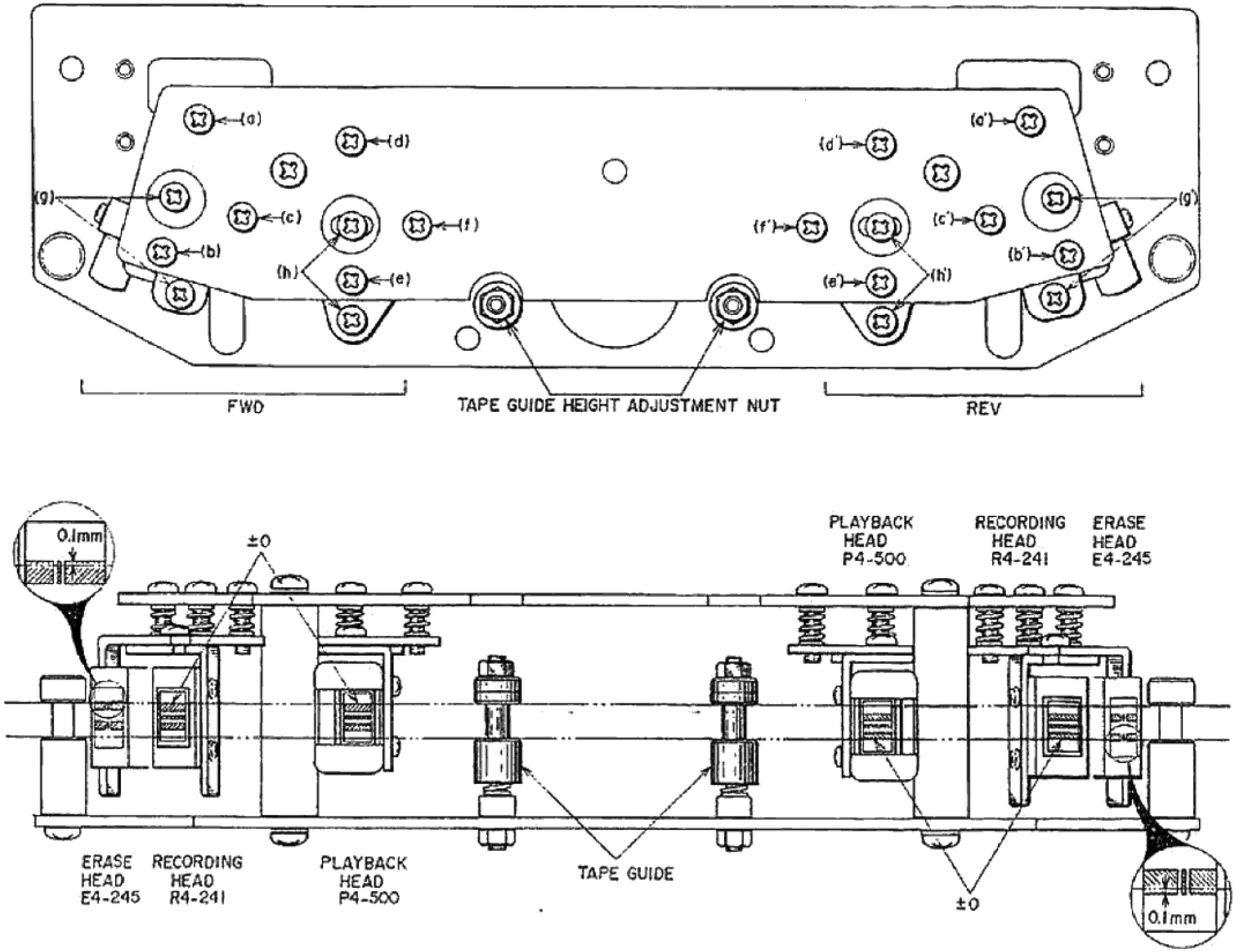

Fig. 42

STEP	ADJUSTMENT ITEM	TEST TAPE SUPPLY SIGNAL	MODE	ADJUSTMENT POINT	REMARKS
1	Tape Guide Height	Optional	FWD	Tape Guide Height Adjustment Nut	1) Adjust so that tape travels smoothly and does not twist. 2) Do not thread tape over tension arm.
2	FWD Recording Head Height	Optional	FWD	(a) (b)	Upper edges of Left Ch. head core and tape are the same height.
3	FWD Erase Head Height Confirmation	Optional	FWD		Upper edge of Left Ch. head core is 0.1 mm higher than upper edge of tape.
4	FWD Playback Head Height	Optional	FWD	(d) (e)	Upper edges of Left Ch. head core and tape are the same height.
5	FWD Playback Head Azimuth Alignment	8,000 Hz 3-3/4 ips Test Tape	FWD	(f)	Maximum output, both channels.
6	FWD Playback Head Angle Alignment	8,000 Hz 3-3/4 ips Test Tape	FWD	(h)	Adjust head gap surface so that there is no change in output level when tension is applied to the supply reel side.
7	FWD Recording Head Azimuth Alignment	Maxell UD 15,000 Hz -20 dBm	REC	(c)	Maximum output, both channels. See NOTE 6.
8	FWD Recording Head Angle Alignment	Maxell UD 15,000 Hz -20 dBm	REC	(g)	Adjust head gap surface so that there is no change in output level when tension is applied to the supply reel side.

Fig. 43

- NOTES: 1. As perfect head adjustments are vital to tape deck performance, be sure that these adjustments are carried out properly.
2. Be careful not to use a magnetized driver or other magnetized tools in the vicinity of the heads.
3. Use only new tape as level variation is likely to occur when using old tape.

4. Demagnetize heads with head demagnetizer before and after head adjustment.
5. Set tape speed to 7-1/2 ips.
6. Set Tape Selector Switch to NORMAL Position.
7. Adjustments outlined in Fig. 43 are only for FWD side heads. However, adjustments for REV side heads are exactly the same.

IX. ELECTRICAL ADJUSTMENT

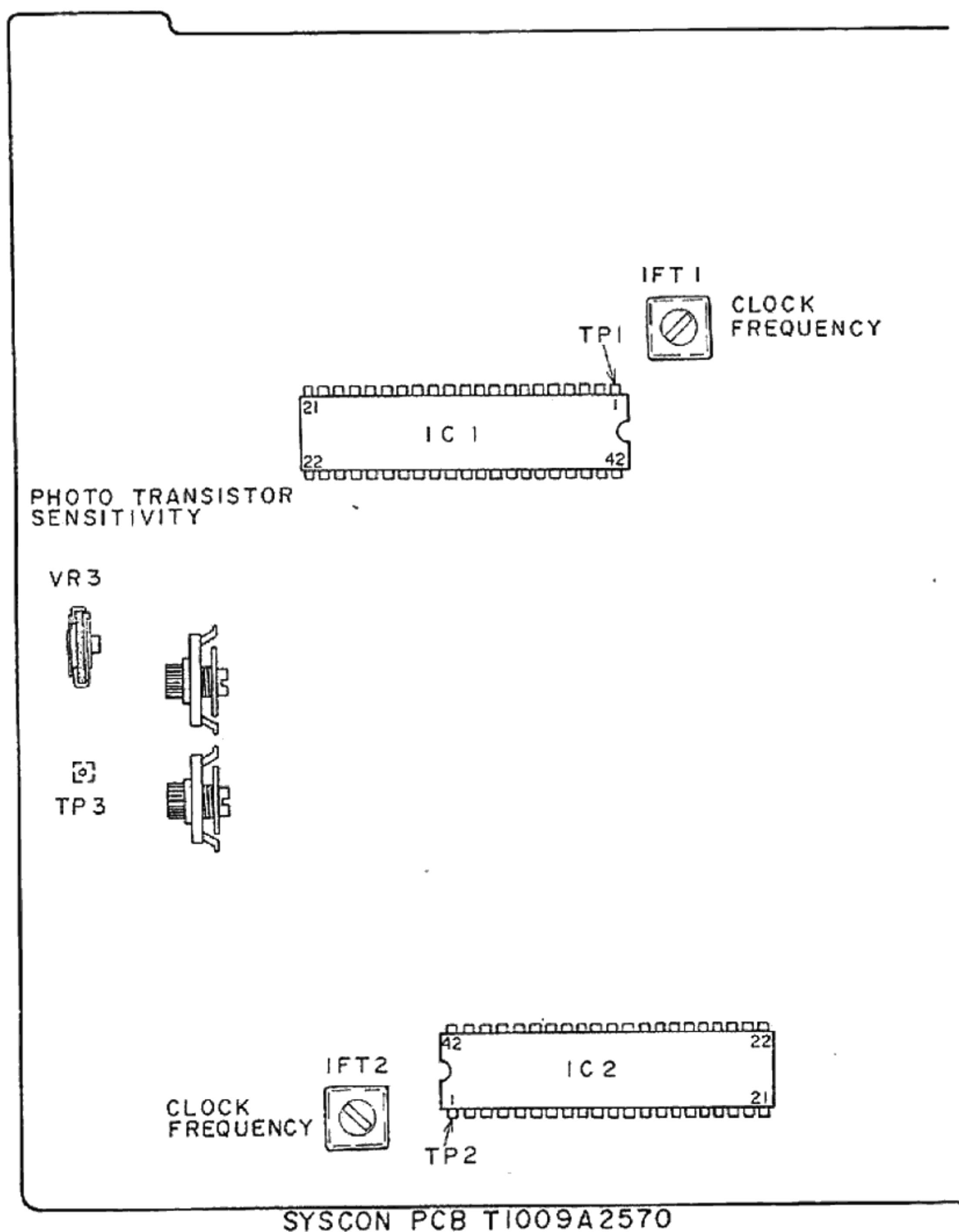

Fig. 44 Syscon P.C Board T1009A2570

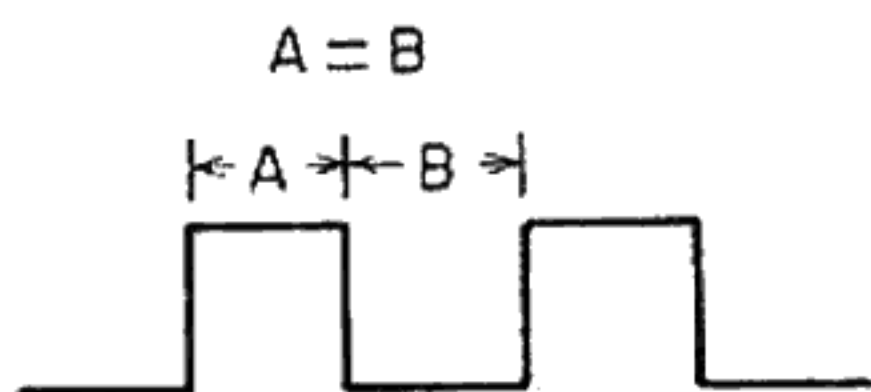

Fig. 45

1. CLOCK FREQUENCY ADJUSTMENT

(Refer to Fig. 44)

Connect the frequency counter between TP1 (IC1 Pin ①) and GND, and adjust with IFT1 so that the indicating values will be from 390 to 400 kHz.

Also for the IC2, make the same adjustment with IFT2.

2. PHOTO TRANSISTOR SENSITIVITY

(Refer to Figs. 44, 45)

Connect the oscilloscope between TP3 and GND. For the reel size 10", adjust with VR3 so that the ON and OFF widths of the pulse will be equal (A=B) as shown in Fig. 45 when the rotation is stabilized in FF or REW mode.

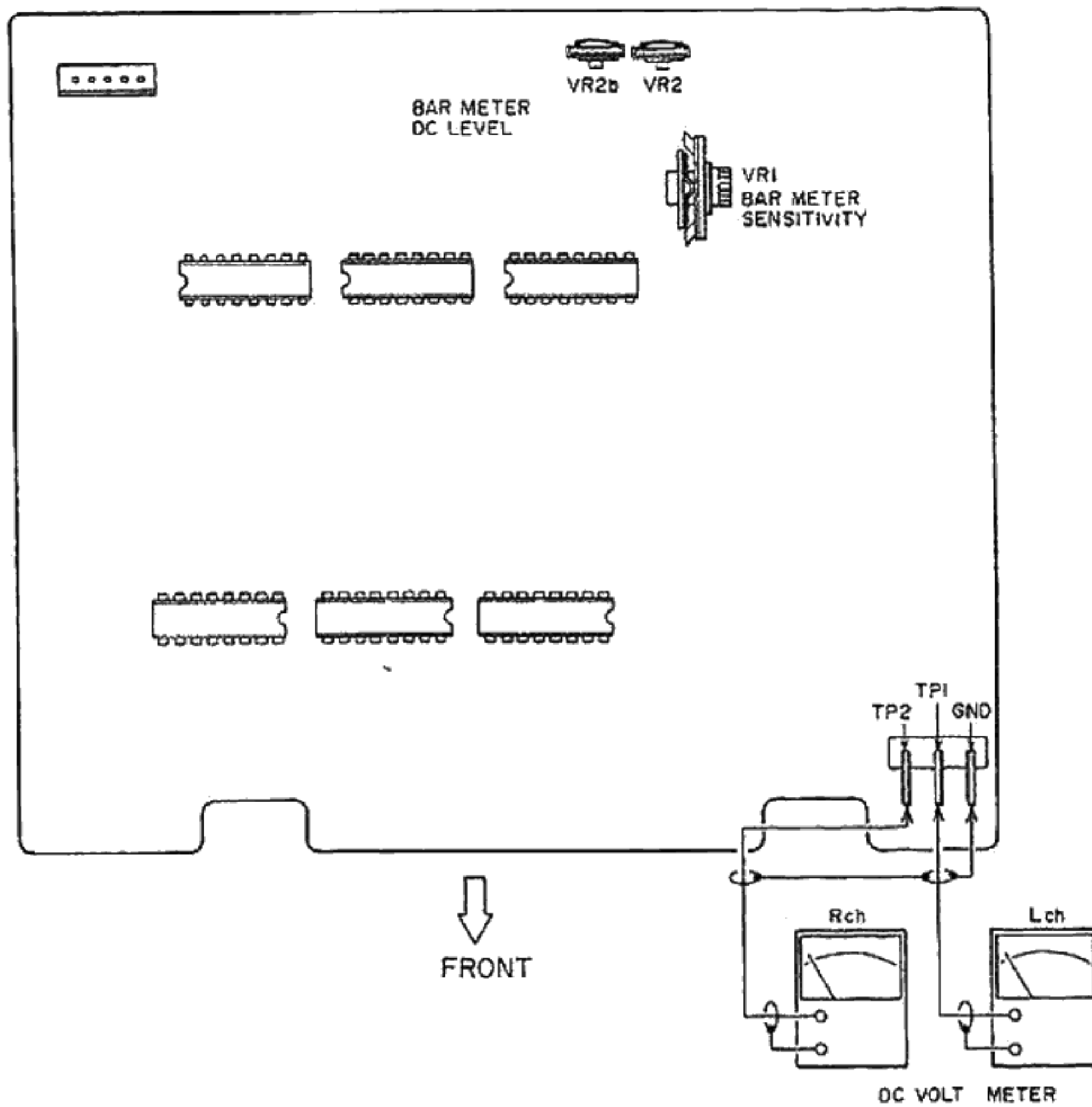

Fig. 46 Bar Meter P.C Board T1009A5020

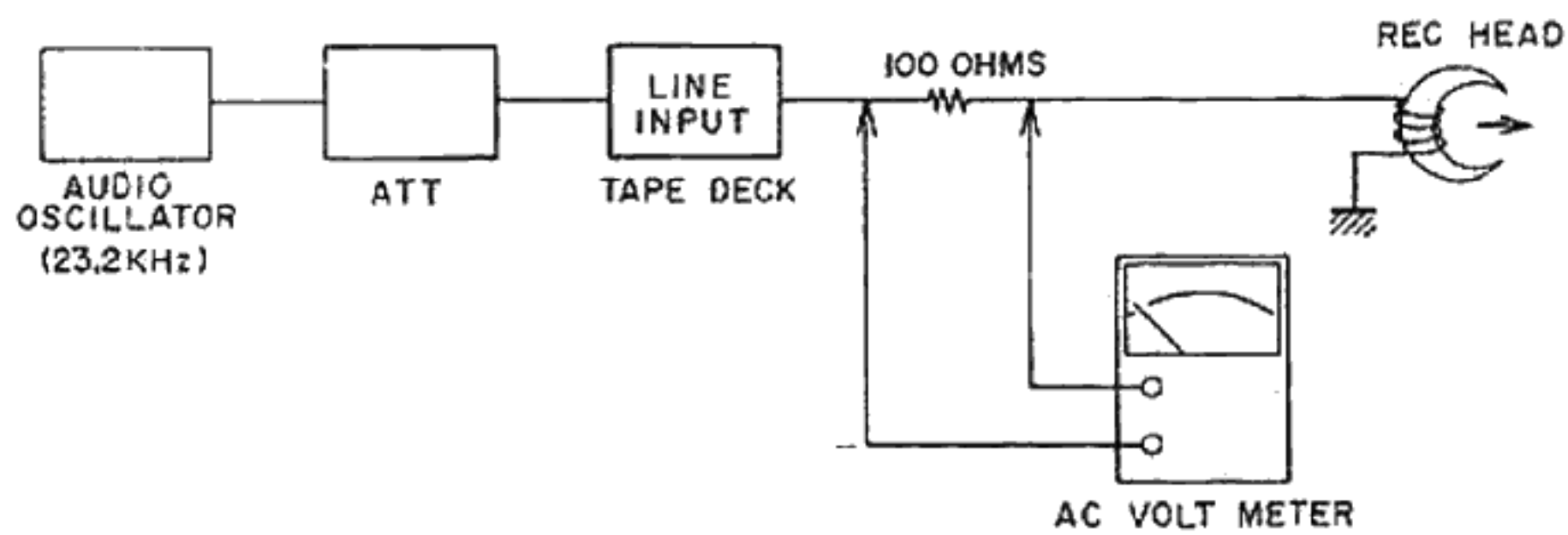

Fig. 47 Rec Peaking Adjustment Instrument Connection

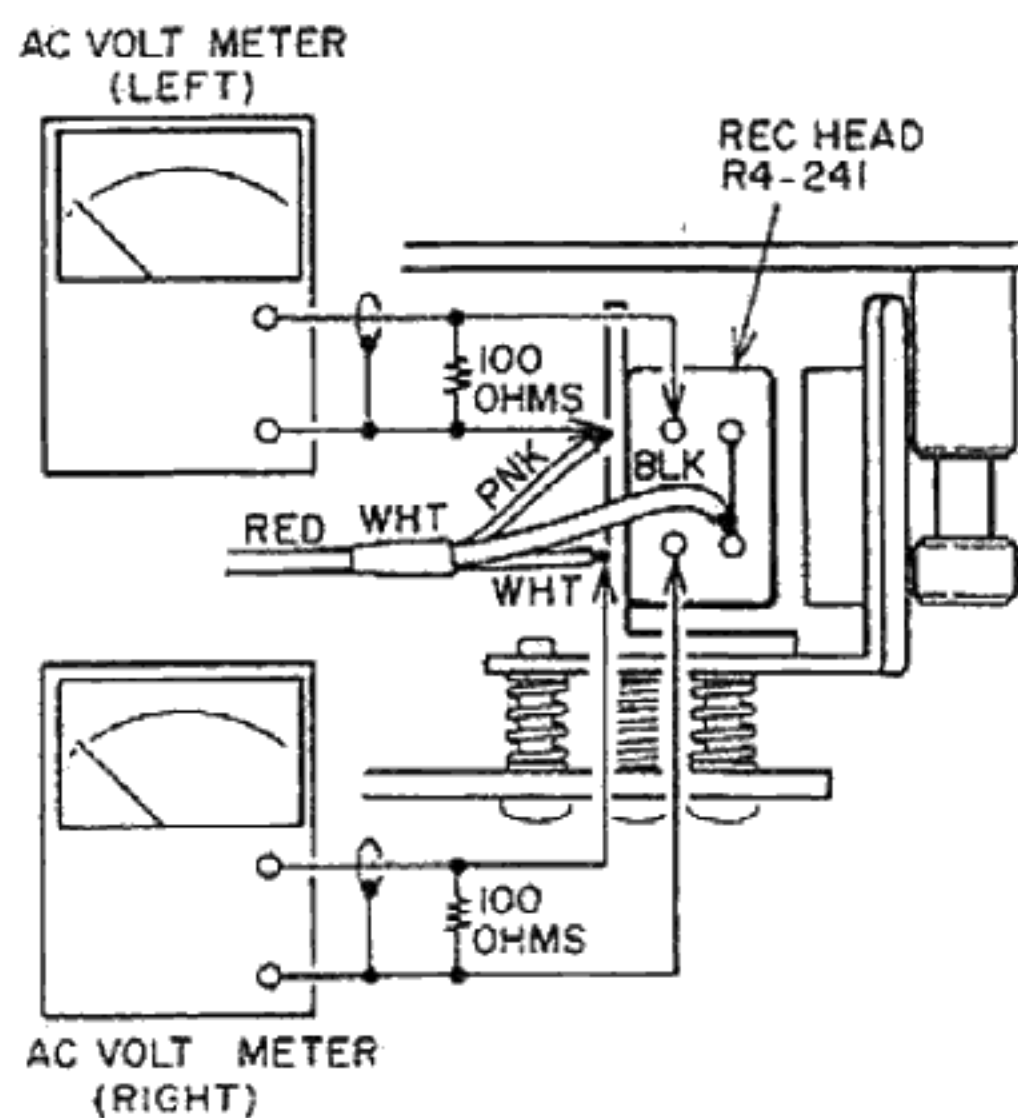

Fig. 48 Rec Peaking Adjustment

STEP	ADJUSTMENT ITEM	TEST TAPE SUPPLY SIGNAL	MODE	ADJUSTMENT POINT	RESULT	REMARKS
1	FWD Playback Level	700 Hz 7-1/2 ips. 0 VU Test Tape	FWD	VR5 50 kB	0 ± 0.5 dBm (0.775V)	
2	REV Playback Level	700 Hz 7-1/2 ips. 0 VU Test Tape	REV	VR6 50 kB	0 ± 0.5 dBm (0.775V)	
3	REC Peaking	23.2 kHz from an Oscillator	REC	VL1 1 mH	Maximum AC Voltmeter indication	Set TAPE SELECTOR to "NORMAL" Tape Speed 3-3/4 ips. See NOTE 6, 7, 9 and Figs. 47, 48, 49.
4	Bar Meter DC Level (Except JPN)	1,000 Hz 0 dBm from an Oscillator	STOP	VR2 10 kB	2.56 to 2.57 V	Set MONITOR Switch to "SOURCE" Bar Meter PCB. Fig. 46.
5	BIAS OSC		REC	T1	100 ± 0.5 kHz	Set TAPE SELECTOR to "NORMAL" Tape Speed 7-1/2 ips. Connect a Frequency Counter between TP and GND. Fig. 49.
6	BIAS Current		REC	VR3 20 kB	135.6 ± 0.5 mV	Set TAPE SELECTOR to "NORMAL" Tape Speed 7-1/2 ips. Connect a AC Volt- meter between TP and GND Fig. 49.
7	FWD Recording Level	NORMAL Blank Tape 1,000 Hz 0 dBm Recording	FWD/ REC	VR2 20 kB	0 ± 0.5 dBm (0.775 V)	
8	REV Recording Level	NORMAL Blank Tape 1,000 Hz 0 dBm Recording	REV/ REC	VR1 20 kB	0 ± 0.5 dBm (0.775 V)	
9	NORMAL Position FWD Frequency Response	NORMAL Blank Tape 1.5 kHz, 15 kHz -20 dBm Recording	FWD/ REC	VC1	1.5 kHz, 15 kHz flat	Tape Speed 3-3/4 ips. Recheck Recording Level.
10	NORMAL Position REV Frequency Response	NORMAL Blank Tape 1.5 kHz, 15 kHz -20 dBm Recording	REV/ REC	VC2	1.5 kHz, 15 kHz flat	Tape Speed 3-3/4 ips. Recheck Recording Level.
11	EE Position Frequency Response (3-3/4 ips)	EE Blank Tape 1.5 kHz, 20 kHz -20 dBm recording	FWD, REV/ REC	VR4 10 kB	1.5 kHz, 20 kHz flat	Tape Speed 3-3/4 ips. Recheck Recording Level.
12	EE Position Frequency Response (7-1/2 ips)	EE Blank Tape 1.5 kHz, 25 kHz -20 dBm Recording	FWD, REV/ REC	VR9 30 kB	1.5 kHz, 25 kHz flat	Tape Speed 7-1/2 ips. Recheck Recording Level.
13	FWD Distortion Confirmation	1,000 Hz 0 dBm Recording	FWD/ REC		NORMAL: EE : See NOTE 8.	Less than 0.5% Less than 0.4%
14	REC Distortion Confirmation	1,000 Hz 0 dBm Recording	REV/ REC		NORMAL: EE : See NOTE 8.	Less than 0.5% Less than 0.4%

STEP	ADJUSTMENT ITEM	TEST TAPE SUPPLY SIGNAL	MODE	ADJUSTMENT POINT	RESULT	REMARKS
15	VU Meter Sensitivity (JPN)	1,000 Hz 0 dBm from an Oscillator	STOP	VR8 1 kB	0 VU indication	Set MONITOR Switch to "SOURCE"
16	Bar Meter Sensitivity (Except JPN)	1,000 Hz 0 dBm from an Oscillator	STOP	VR1 100 k	0 VU indication	Set MONITOR Switch to "SOURCE" Bar Meter PCB Fig. 46 See NOTE 10, 11.

- NOTES:
1. Output Level Control should be at maximum.
 2. Except for Steps 3, 9, 10 and 11, set Tape Speed to 7-1/2 ips.
 3. Except for Steps 11 to 13 and 14, set Tape Selector Switch to NORMAL Position.
 4. Set Bias Adjustment Volume to center position.
 5. Use the following open measuring tapes:
NORMAL Tape: Maxell UD
EE Tape : Maxell XLII
TDK SA
 6. Stop Recording bias oscillator while making Rec Peaking adjustment (Refer to Fig. 49).
 7. When 23.2 kHz indicates the peak, check

- and ensure that the AC Voltmeter show 16 dB of increase when 15 kHz of input is fed rather than when 1 kHz is fed.
8. If it does not comply with the specifications repeat Steps 7 to 11 and 12, and re-adjust.
9. Unless the core is moved intentionally this adjustment is not necessary.
10. Adjust VR1 to cause the bar meter to come on from the low level, and set the VR1 to the position where the bar meter has come on at 0 dB.
11. Confirm that the 0 dB on the Bar Meter is lit while adjusting the line out level to within 0.3 dB.

X. DC RESISTANCE OF VARIOUS COILS

PART	DESIGNATION	DC RESISTANCE
Main Motor	SCM-200	Between BLU-RED: 110 ohms Between YLW-BRN: 170 ohms Pick-up Coil: 665 ohms
Reel Motor	24X0-TD	Between BLU-RED: 30 ohms Between YLW-BRN: 157 ohms
Pinch Roller Plunger	1664PLT1	600 ohms \pm 10%
Brake Plunger REV Plunger	1240PLT1	600 ohms \pm 10%
Pause Plunger	0730FLT	600 ohms \pm 10%
Relay	MY4-02-US-L	650 ohms \pm 15%
Relay	BR211	1,280 ohms \pm 10%
Relay	G2KU	1,000 ohms \pm 10%
Relay	321D012	230 ohms \pm 15%
Erase Head	E4-245	3.1 ohms
Recording Head	R4-241	5.9 ohms
Playback Head	P4-500	407 ohms \pm 5%

XI. CLASSIFICATION OF VARIOUS P.C BOARDS

1. P.C BOARD TITLES AND IDENTIFICATION NUMBERS

P.C BOARD TITLE	P.C BOARD NUMBER	REMARKS
Syscon P.C Board	T1009A2570	
Pre Amp P.C Board	T1009A510A	
VU Meter P.C Board (L, R)	T1009A510B, C	JPN
Mic Amp P.C Board	T1009B5010	
Bar Meter P.C Board	T1009B5020	EXCEPT JPN
Operation P.C Board	T1009C2390	
Fuse (A) P.C Board	T1009D2440	
Fuse (B) P.C Board	T1009C2450	
Counter P.C Board	T1009C2550	
Lamp P.C Board	T1009C5240	EXCEPT JPN
Equalizer P.C Board	T1009D530A	
Bias, Adjustment P.C Board	T1009D530B	
Remocon P.C Board	T1009D2420	
Switch P.C Board	T1009D2500	
Detector (A) P.C Board	T1009D2540	
Detector (B) P.C Board	T1009D2520	

2. COMPOSITION OF VARIOUS P.C BOARDS

1) Pre Amp P.C Board T1009A510A, VU Meter P.C Board T1009A510B (J), Equalizer P.C Board T1009D530A and Bias Adjust P.C Board T1009D530B

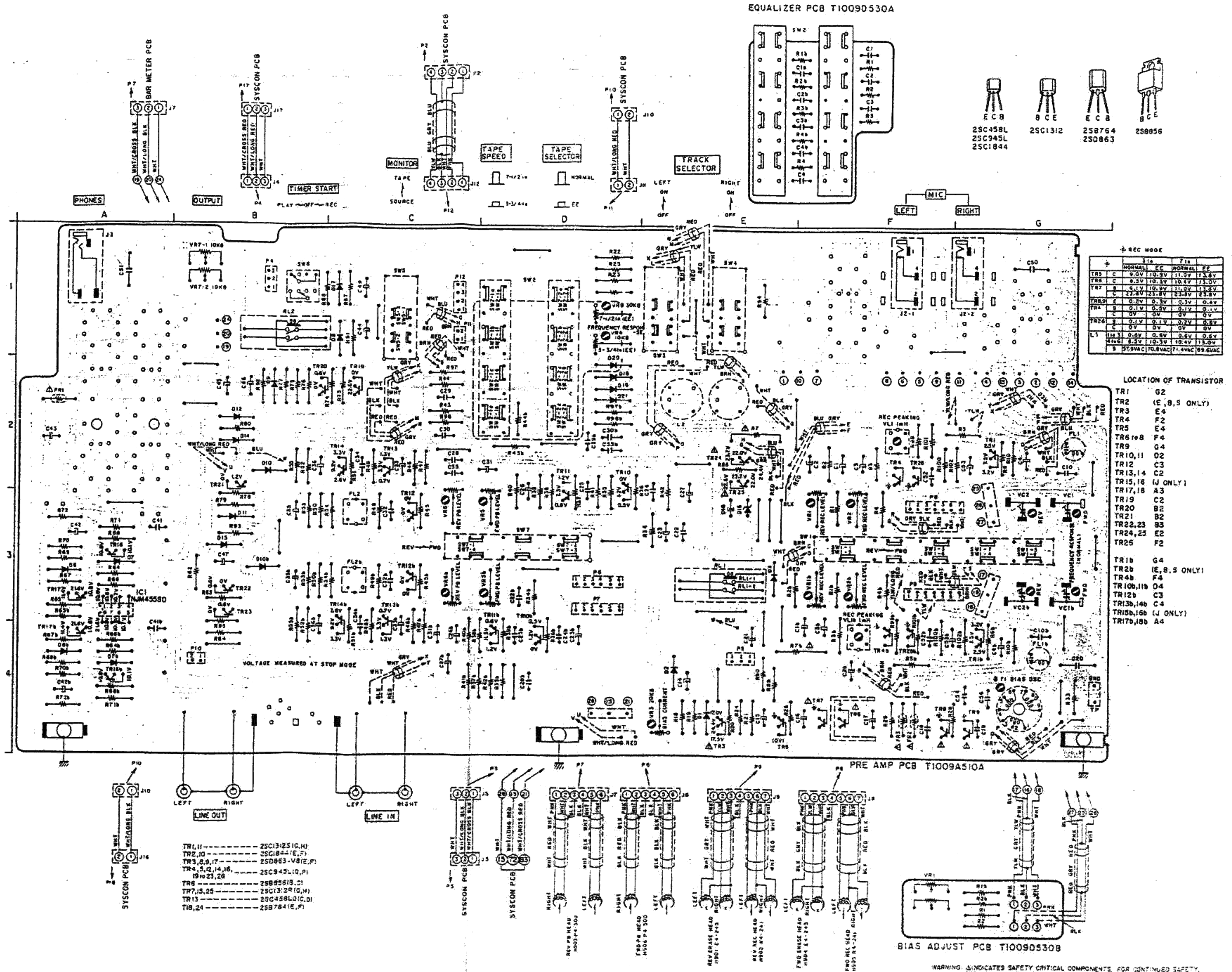

WARNING: INDICATES SAFETY CRITICAL COMPONENTS FOR CONTINUED SAFETY. REPLACE SAFETY CRITICAL COMPONENTS ONLY WITH MANUFACTURER'S RECOMMENDED PARTS.

AVERTISSEMENT: AIL INDIQUÉ LES COMPOSANTS CRITIQUES DE SÛRETÉ. POUR MAINTENIR LE DEGRÉ DE SÛRETÉ DE L'APPAREIL, NE REMPLACER LES COMPOSANTS DONT LE FONCTIONNEMENT EST CRITIQUE POUR LA SÛRETÉ QUE PAR DES PIÈCES RECOMMANDÉES PAR LE FABRICANT.

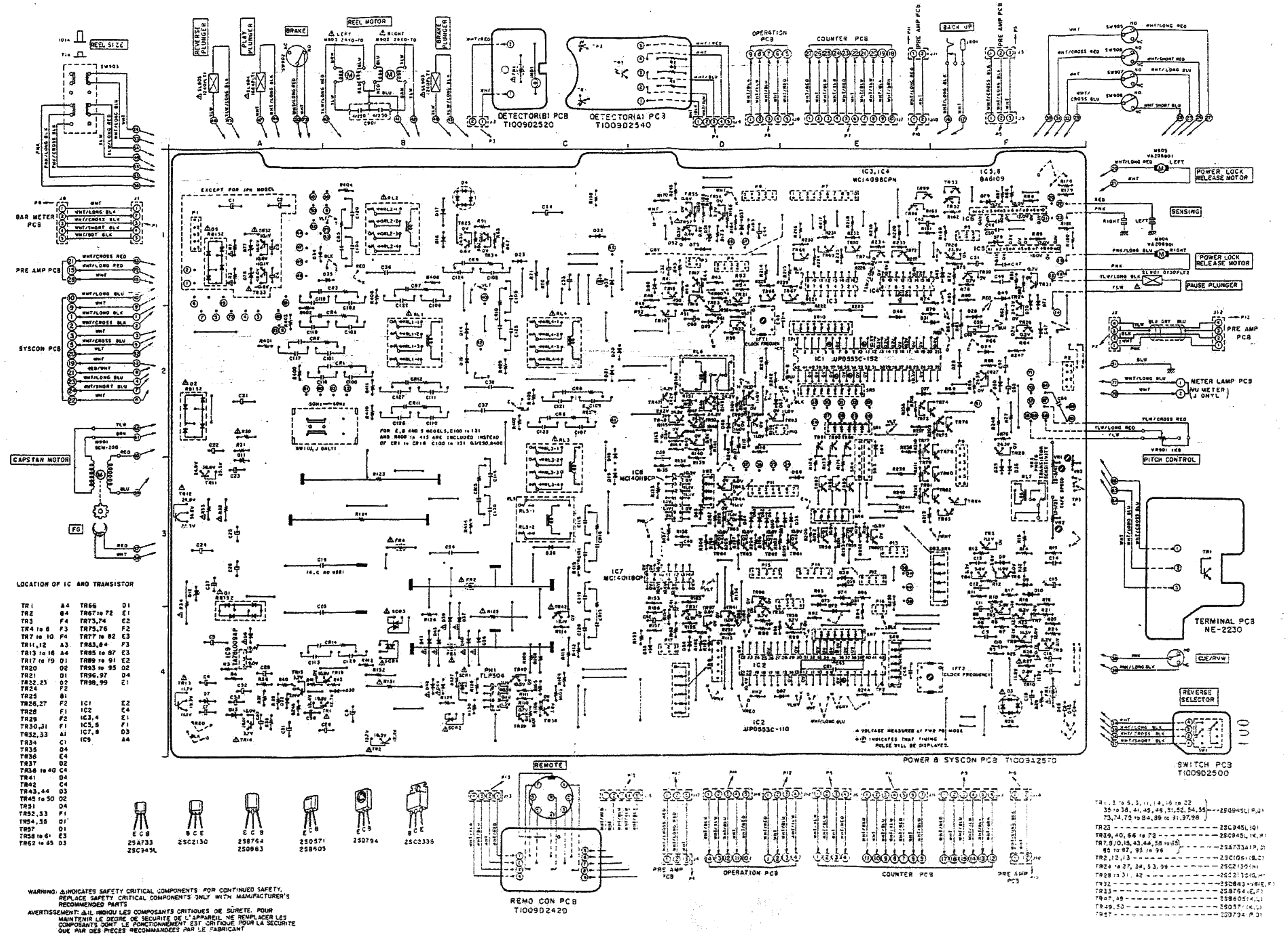

LOCATION OF IC AND TRANSISTOR

TR1	A4	TR66	D1
TR2	B4	TR67 to 72	E1
TR3	F4	TR73,74	F2
TR4 to 6	F3	TR75,76	F2
TR7 to 10	F4	TR77 to 82	E3
TR11,12	A3	TR83,84	F3
TR13 to 16	A4	TR85 to 87	E3
TR17 to 19	O1	TR89 to 91	E2
TR20	O2	TR93 to 95	O2
TR21	O1	TR96,97	O4
TR22,23	O2	TR98,99	E1
TR24	F2		
TR25	B1		
TR26,27	F2	IC1	E2
TR28	F1	IC2	E4
TR29	F2	IC3,4	E1
TR30,31	F1	IC5,6	F1
TR32,33	A1	IC7,8	O3
TR34	C1	IC9	A4
TR35	O4		
TR36	E4		
TR37	O2		
TR38 to 40	C4		
TR41	O4		
TR42	C4		
TR43,44	O3		
TR45 to 50	O2		
TR51	O4		
TR52,53	F1		
TR54,55	O1		
TR57	O1		
TR58 to 61	E3		
TR62 to 65	O3		

- ECB 25A733 25C745L
- BCE 25C2130
- ECB 25B764 25B963
- ECB 25O571 25B405
- ECB 25O794
- BCE 25C2335

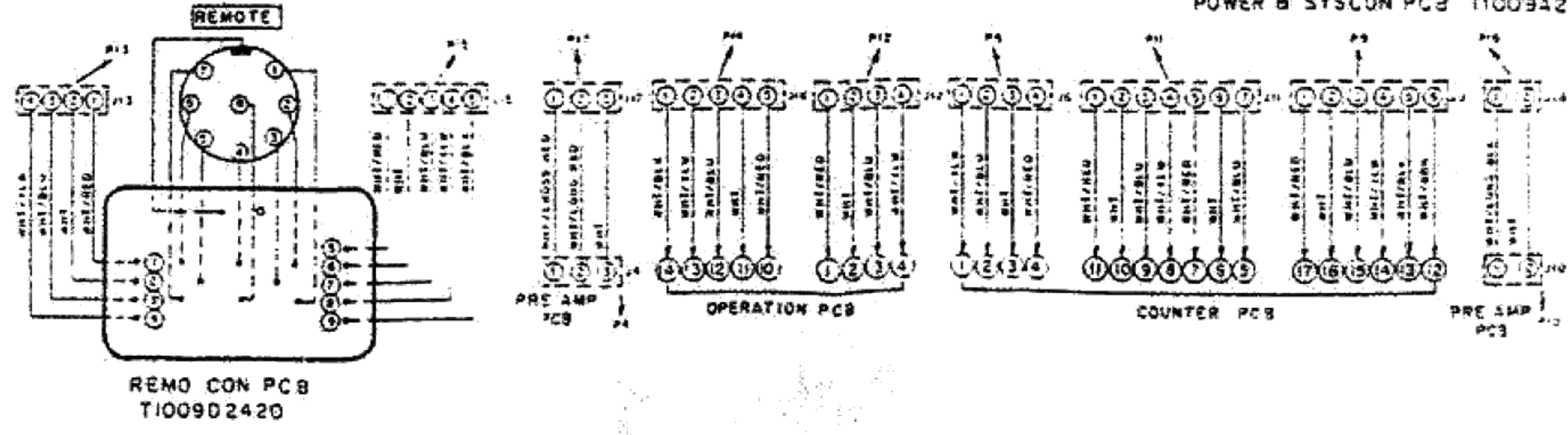

- TR1,3 to 5,8,11,14,16 to 22 35 to 38,41,45,46,51,52,54,55 73,74,75 to 80,89 to 91,97,98
- TR29,40,56 to 72
- TR7,9,10,15,43,44,58 to 60 80 to 87,93 to 98
- TR2,12,13
- TR4 to 27,34,53,99
- TR8 to 31,42
- TR32
- TR33
- TR47,48
- TR49,50
- TR57

3) Mic Amp P.C Board T1009B5010

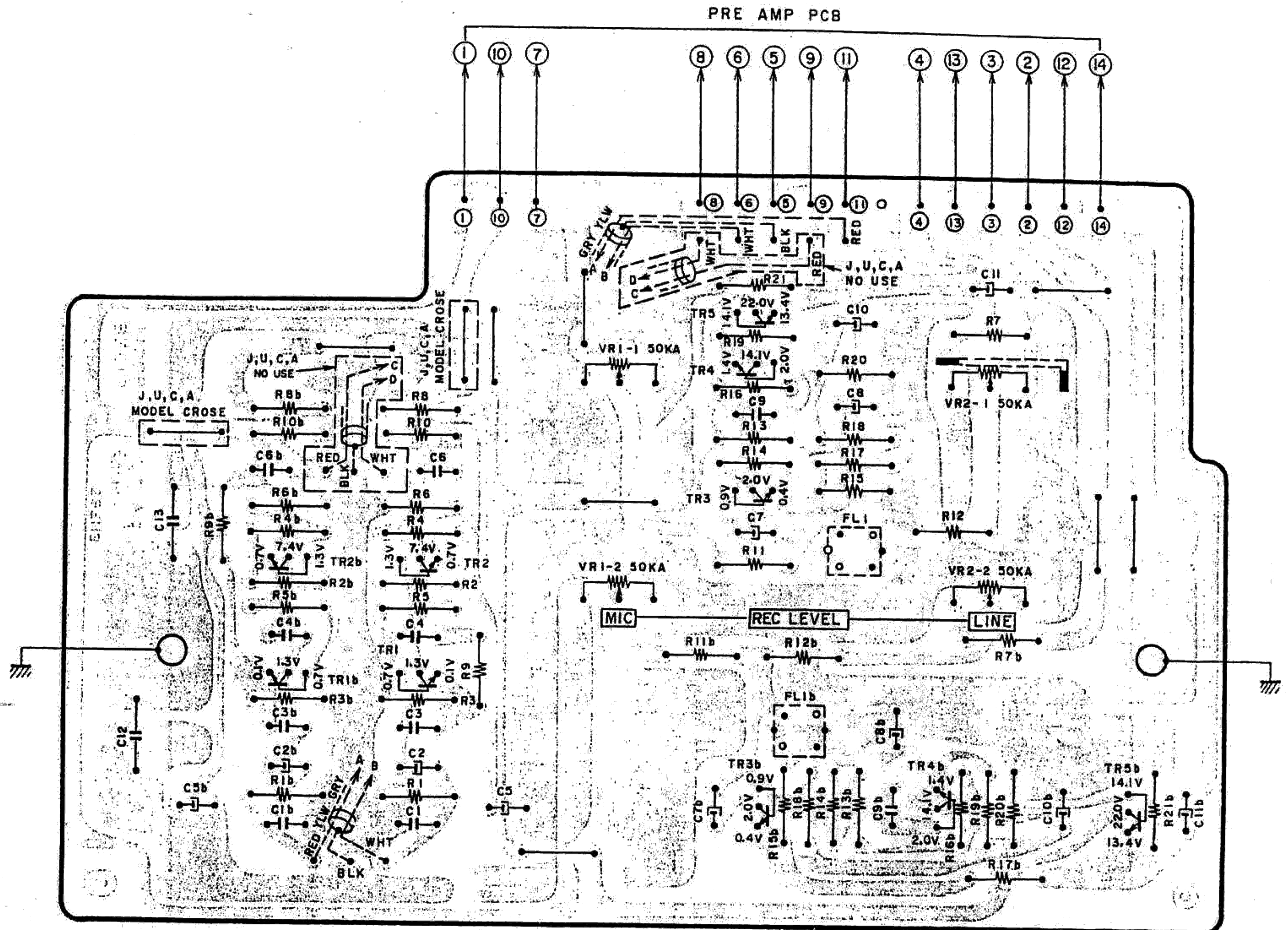

TR 1,3 --- 2SC1844(E,F)
 TR 2 ----- 2SC1312S(G,H)
 TR 4,5 ---- 2SC945L(P,Q)

MIC AMP PCB T1009B5010

E C B
 2SC945L
 2SC1844

B C E
 2SC1312

4) Bar Meter P.C Board T1009B5020 and Lamp P.C Board T1009C5240

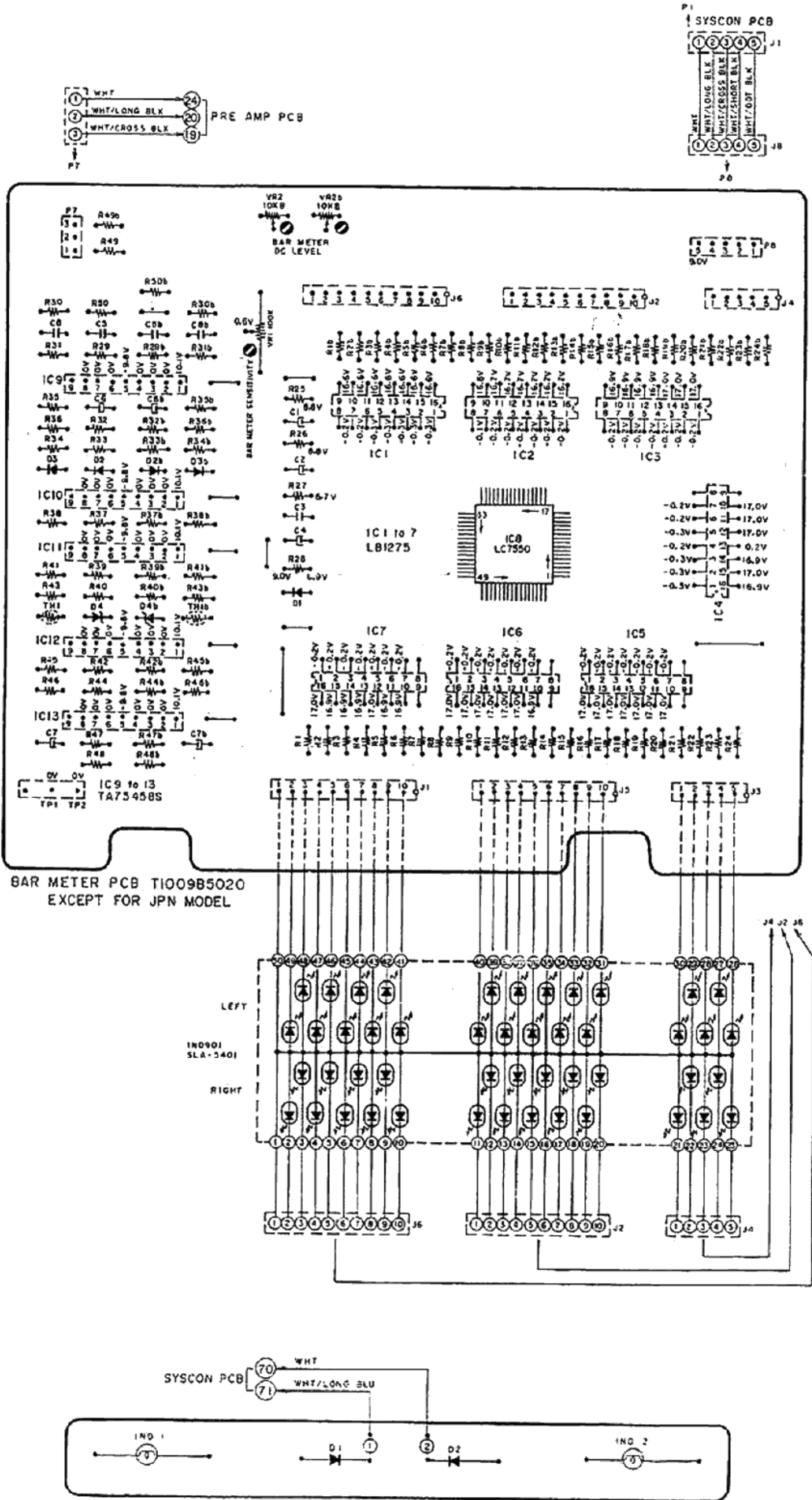

5) Operation P.C Board T1009C2390

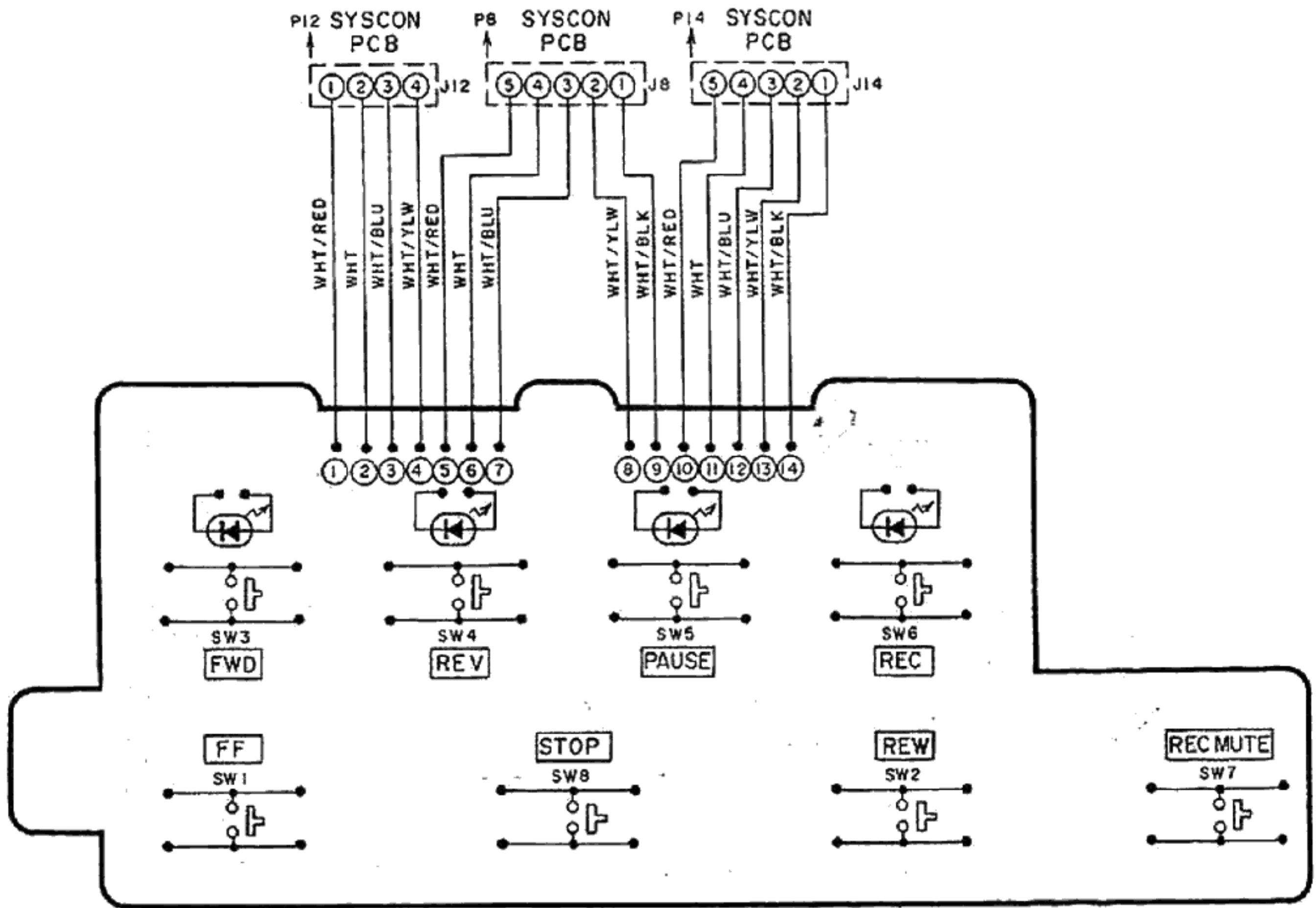

6) Counter P.C Board T1009C2550

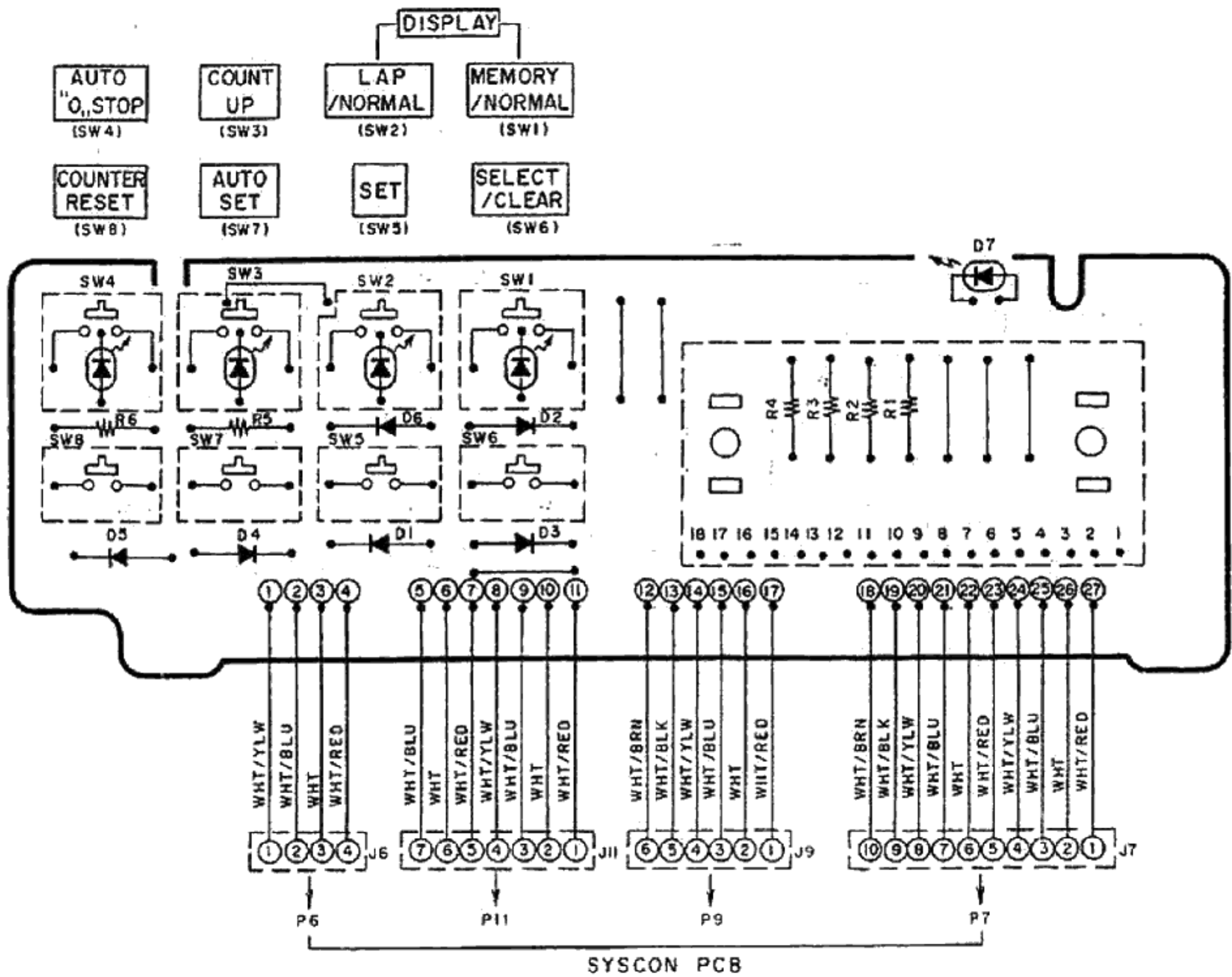

7) Fuse (A) P.C Board T1009D2440

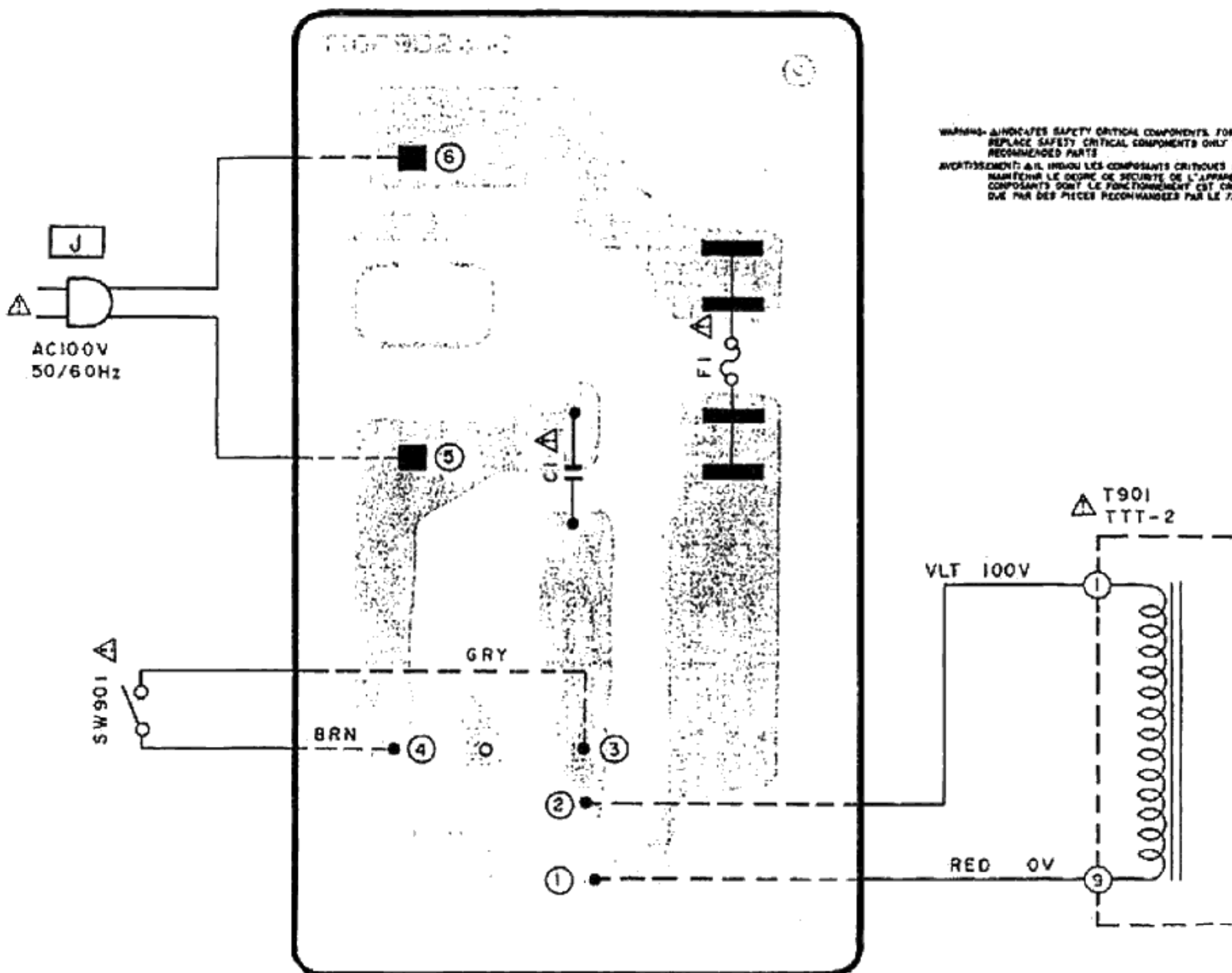
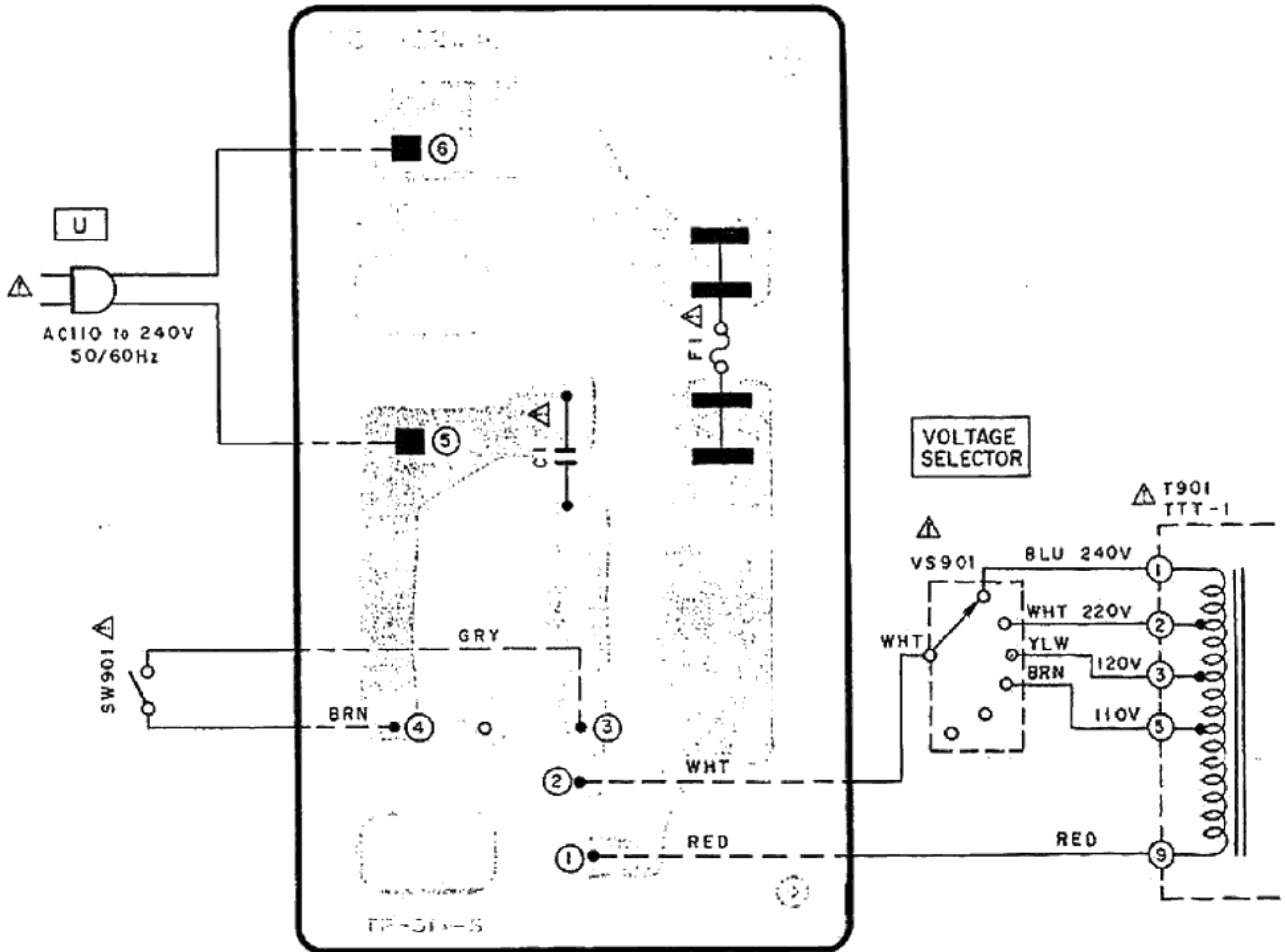

WARNING-INDICATES SAFETY CRITICAL COMPONENTS. FOR CONTINUED SAFETY, REPLACE SAFETY CRITICAL COMPONENTS ONLY WITH MANUFACTURER'S RECOMMENDED PARTS.

AVERTISSEMENT-IL INDIQUE LES COMPOSANTS CRITIQUES DE SURETE. POUR MAINTENIR LE DEGRÉ DE SURETE DE L'APPAREIL, NE REMPLACER LES COMPOSANTS DON'T LE FONCTIONNEMENT EST CRITIQUE POUR LA SECURITE QUE PAR DES PIÈCES RECOMMANDÉES PAR LE FABRICANT.

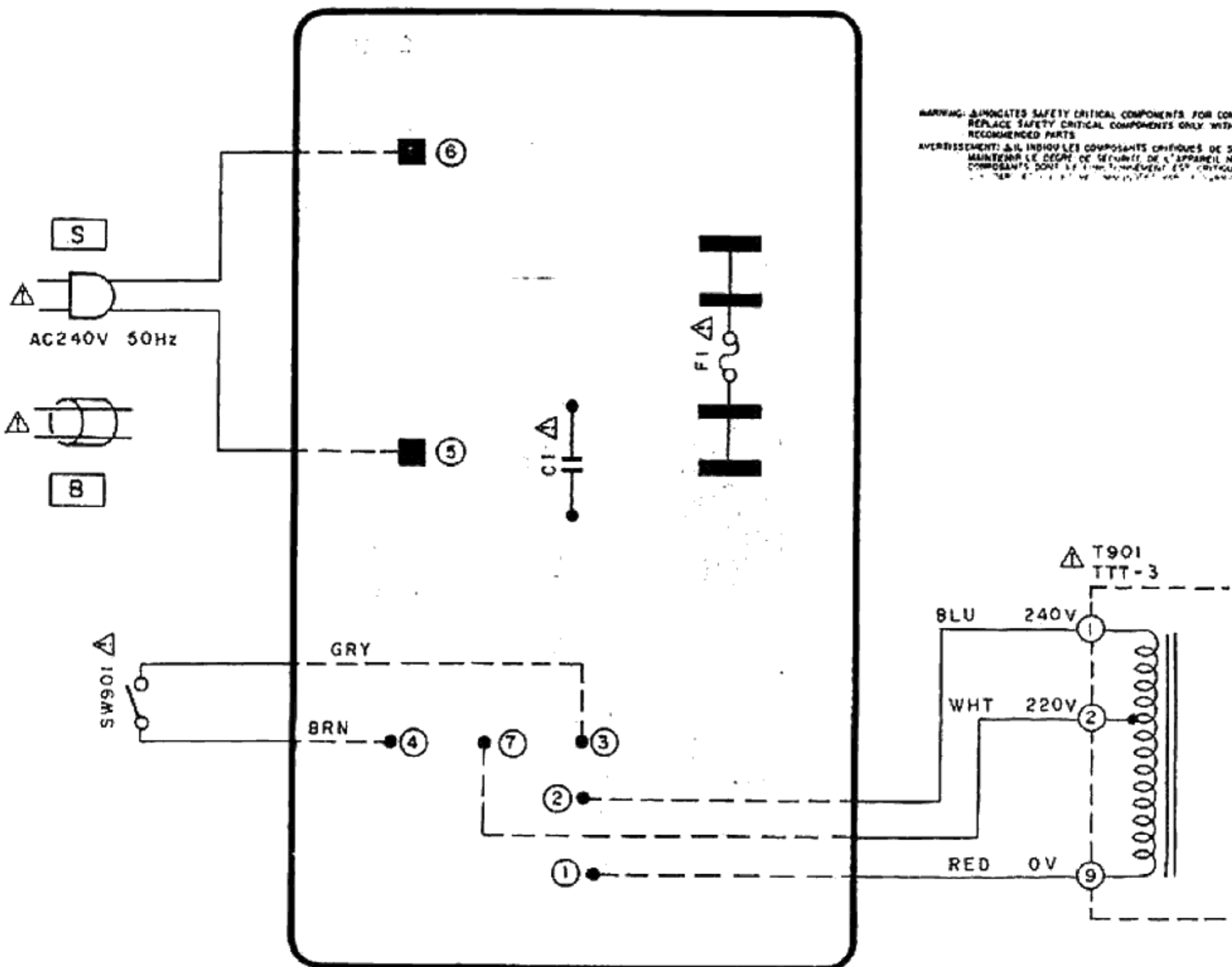
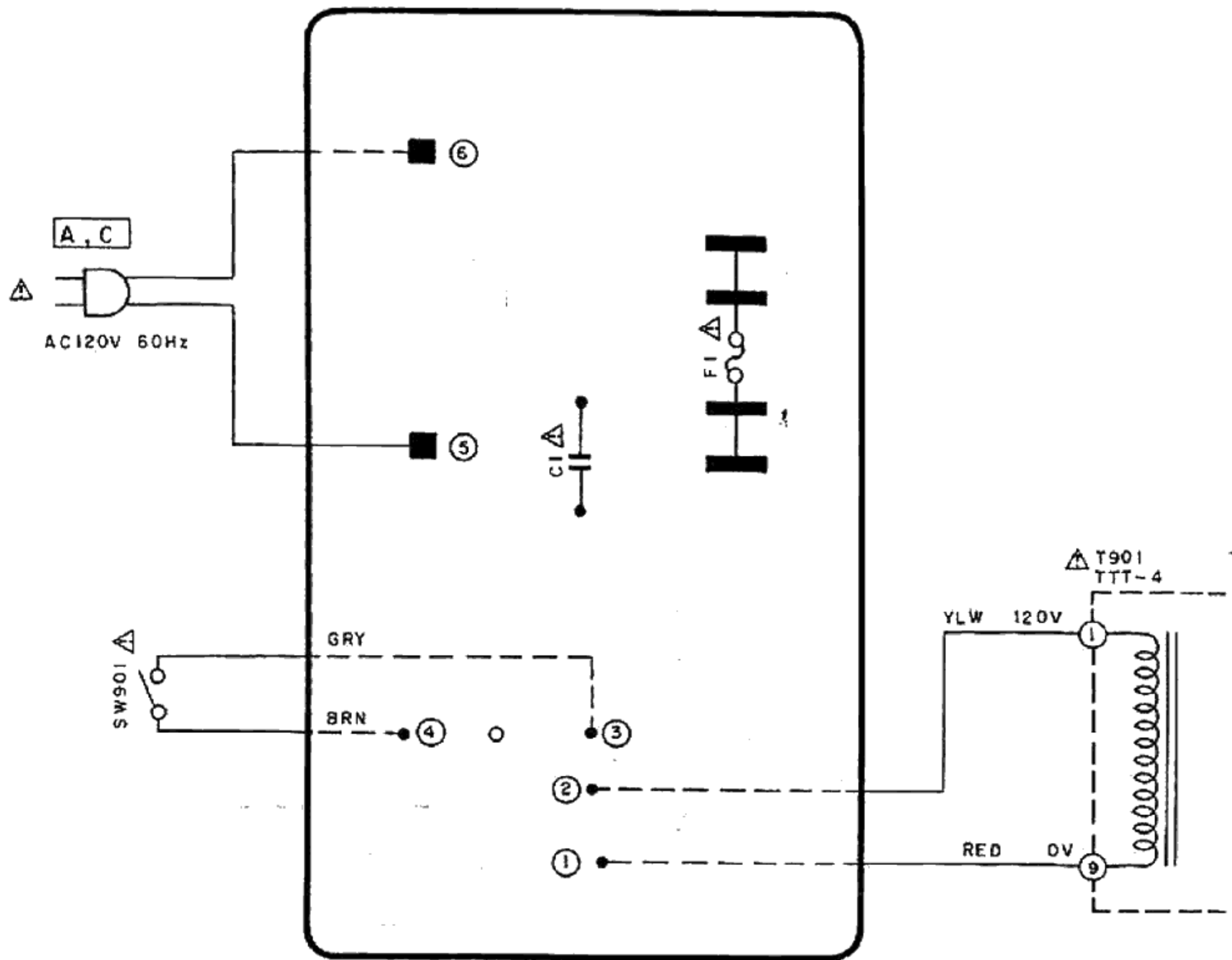

WARNING: Δ INDICATES SAFETY CRITICAL COMPONENTS FOR CONTINUED SAFETY. REPLACE SAFETY CRITICAL COMPONENTS ONLY WITH MANUFACTURER'S RECOMMENDED PARTS.

AVERTISSEMENT: Δ INDIQUE LES COMPOSANTS CRITIQUES DE SÛRETÉ. POUR MAINTENIR LE DEGRÉ DE SÛRETÉ DE L'APPAREIL NE REMPLACEZ LES COMPOSANTS DONT LE FONCTIONNEMENT EST CRITIQUE QUE PAR DES SÛRTE

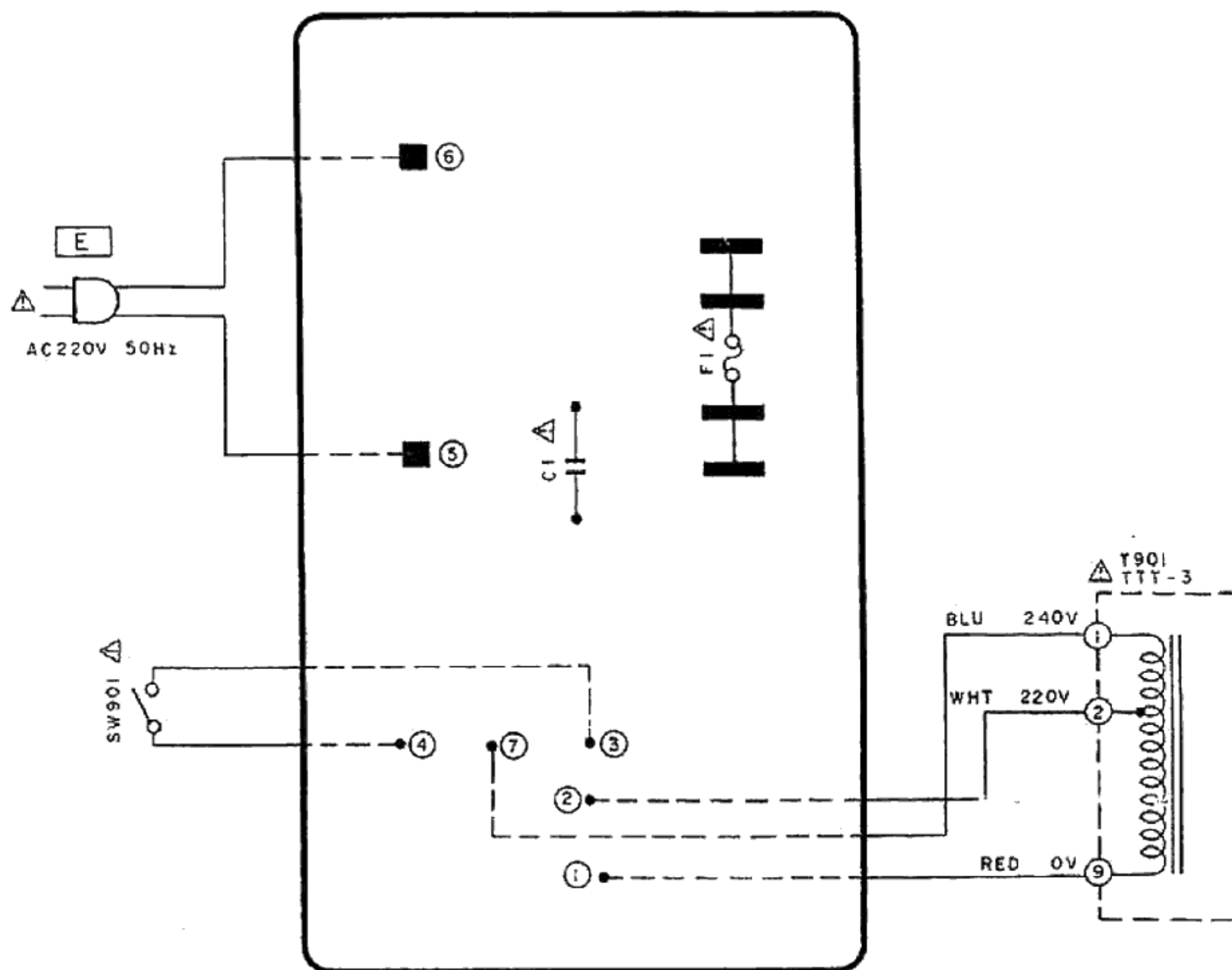

WARNING: Δ INDICATES SAFETY CRITICAL COMPONENTS. FOR CONTINUED SAFETY, REPLACE SAFETY CRITICAL COMPONENTS ONLY WITH MANUFACTURER'S RECOMMENDED PARTS

AVERTISSEMENT: Δ IL INDIQU LES COMPOSANTS CRITIQUES DE SÛRETÉ. POUR MAINTENIR LE DEGRÉ DE SÛRETÉ DE L'APPAREIL NE REMPLACER LES COMPOSANTS DONT LE FONCTIONNEMENT EST CRITIQUE POUR LA SÛRETÉ QUE PAR DES PIÈCES RECOMMANDÉES PAR LE FABRICANT

8) Fuse (B) P.C Board T1009C2450

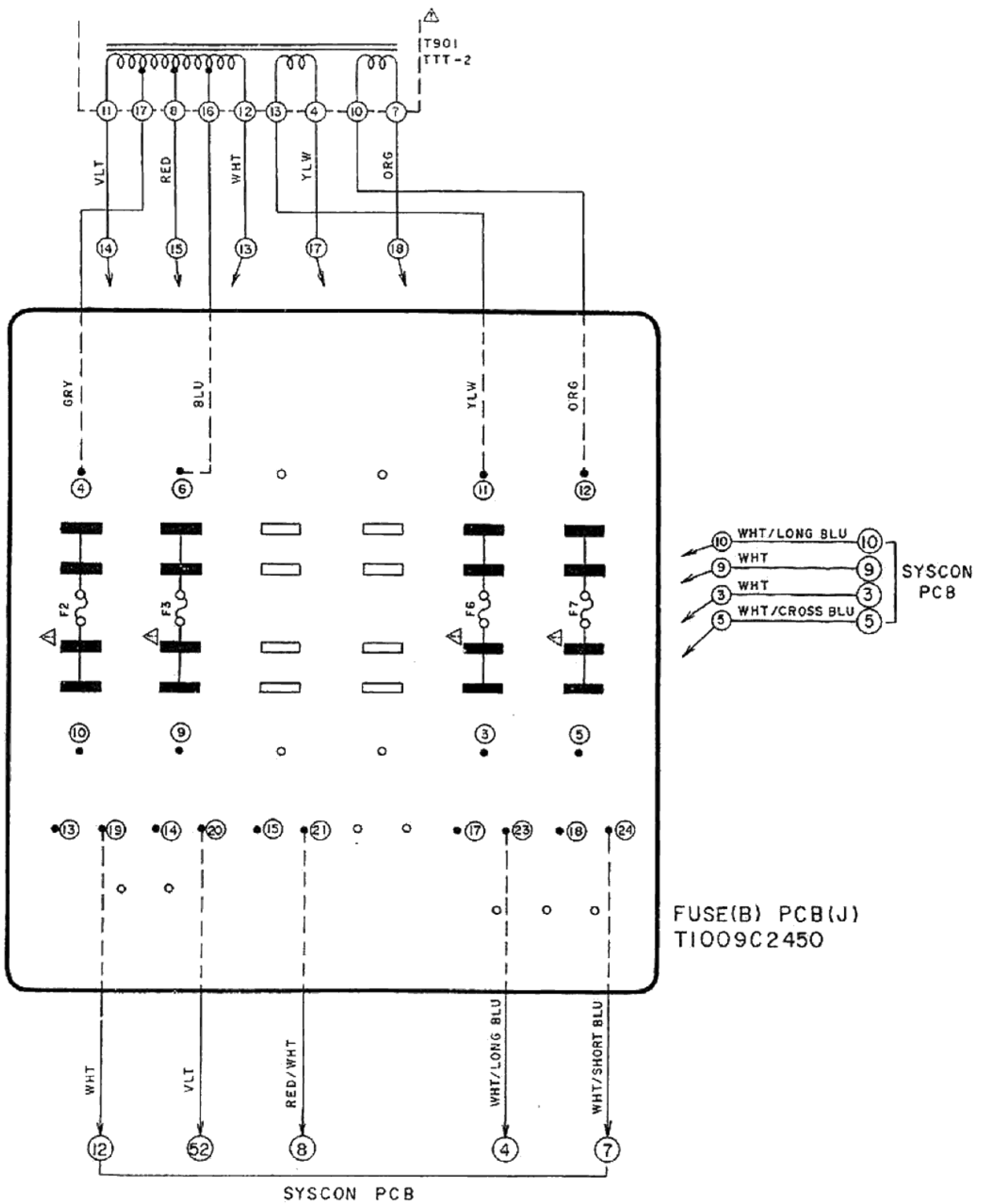

WARNING: ⚠ INDICATES SAFETY CRITICAL COMPONENTS. FOR CONTINUED SAFETY, REPLACE SAFETY CRITICAL COMPONENTS ONLY WITH MANUFACTURER'S RECOMMENDED PARTS.

AVERTISSEMENT: ⚠ IL INDIQUE LES COMPOSANTS CRITIQUES DE SÛRETÉ. POUR MAINTENIR LE DEGRÉ DE SÛRETÉ DE L'APPAREIL NE REMPLACER LES COMPOSANTS DONT LE FONCTIONNEMENT EST CRITIQUE POUR LA SÛRETÉ QUE PAR DES PIÈCES RECOMMANDÉES PAR LE FABRICANT.

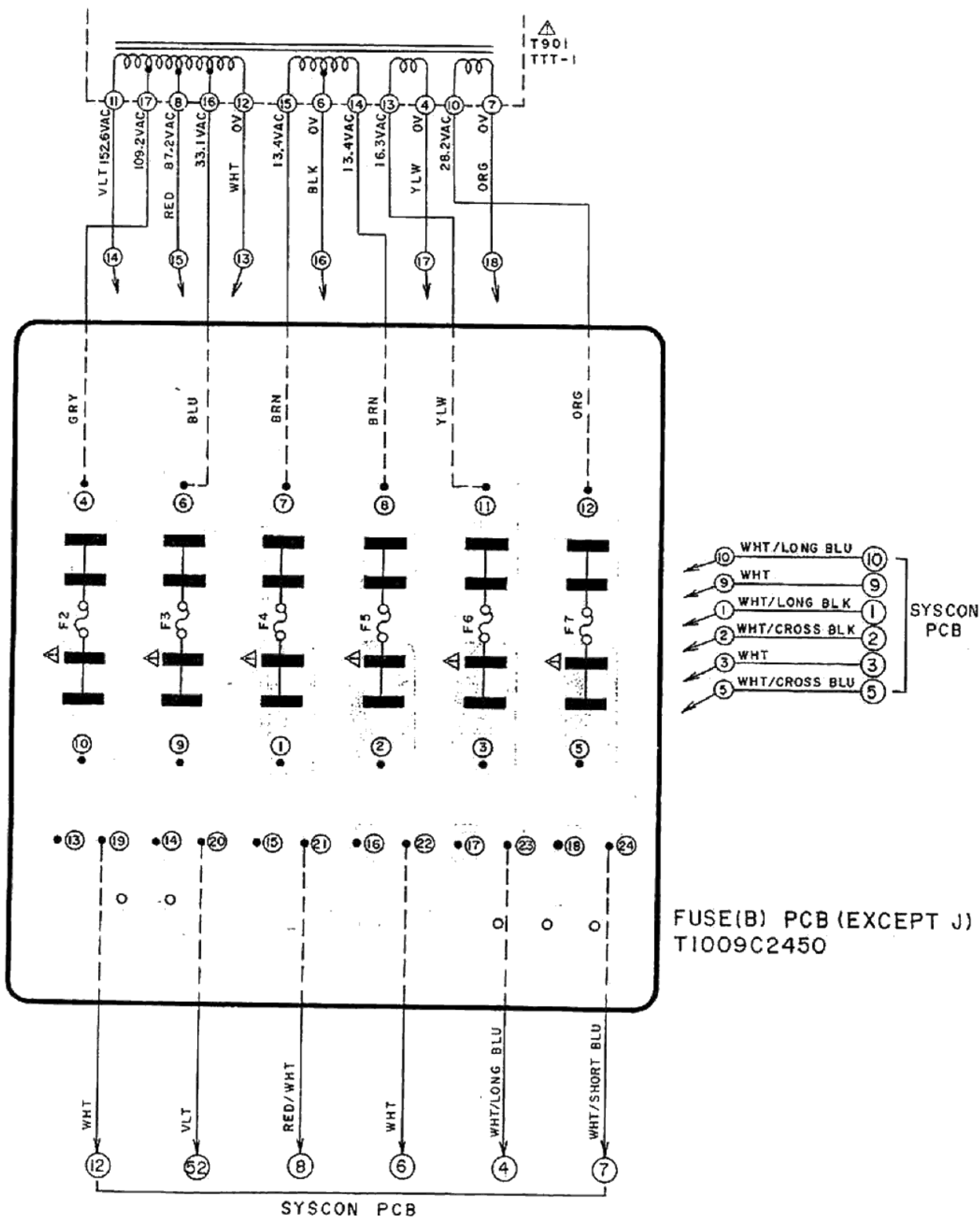

WARNING: Δ INDICATES SAFETY CRITICAL COMPONENTS. FOR CONTINUED SAFETY, REPLACE SAFETY CRITICAL COMPONENTS ONLY WITH MANUFACTURER'S RECOMMENDED PARTS.
 AVERTISSEMENT: Δ IL INDIQUE LES COMPOSANTS CRITIQUES DE SÛRETÉ. POUR MAINTENIR LE DEGRÉ DE SÛRETÉ DE L'APPAREIL, NE REMPLACER LES COMPOSANTS DONT LE FONCTIONNEMENT EST CRITIQUE POUR LA SÛRETÉ QUE PAR DES PIÈCES RECOMMANDÉES PAR LE FABRICANT.

SECTION 2

PARTS LIST

TABLE OF CONTENTS

1. RECOMMENDED SPARE PARTS	51
2. HEAD BLOCK	52
3. MOTOR BLOCK	53
4. REEL TABLE BLOCK	54
5. ROLLER TABLE (L) BLOCK ROLLER TABLE BLOCK	55
6. POWER BLOCK	56
7. MECHA BLOCK	57
8. SYS. CON. P.C BOARD BLOCK	58
9. PRE AMP P.C BOARD BLOCK	59
10. MIC AMP P.C BOARD BLOCK	59
11. BAR METER P.C BOARD BLOCK	59
12. COUNTER P.C BOARD BLOCK	59
13. ASSEMBLY BLOCK	60
14. FINAL ASSEMBLY BLOCK	61
INDEX	62

Resistor and Capacitor which is not listed in this parts list, please refer to COMMON LIST FOR SERVICE PARTS.

HOW TO USE THIS PARTS LIST

1. This parts list is compiled by various individual blocks based on assembly process.
2. When ordering parts, please describe parts number, serial number, and model number in detail.
3. How to read list.

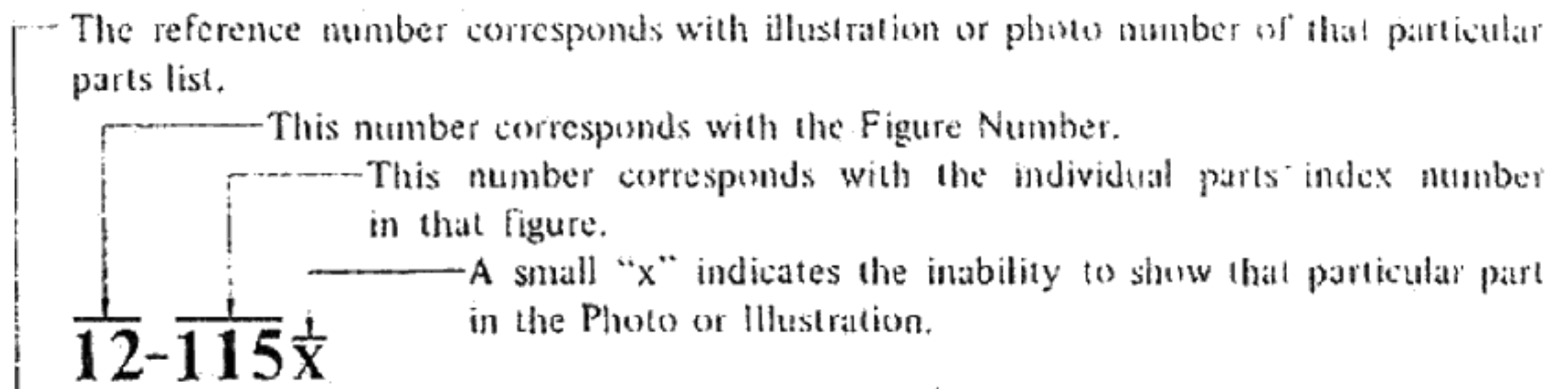

Ref. No.	Parts No.	Description
FLYWHEEL BLOCK #13		
12-115x	800425	Flywheel Block Assy. Comp.
12-116	244506	Flywheel Only
12-117x	244754	Felt, Flywheel
12-118	251324	Main Metal Case
12-119	253080	Main Metal

4. The symbol numbers shown on the P.C. Board list can be matched with the Composite Views of components of the Schematic Diagram or Service Manual.
5. The indications of Resistors and Capacitors in the photos of P.C. Board are being eliminated.
6. The shape of the parts and parts name, etc. can be confirmed by comparing them with the parts shown on the Electrical Parts Table of P.C. Board.
7. Both the kind of part and installation position can be determined by the Parts Number. To determine where a parts number is listed, utilize Parts Index at end of Parts List.
It is necessary first of all to find the Parts Number. This can be accomplished by using the Reference Number listed at right of parts number in the Parts Index. (meaning of ref. no. outlined in Item 3 above).
8. Utilize separate "Price List for Parts" to determine unit price. The most simple method of finding parts Price is to utilize the reference number.

CAUTION:

1. When placing an order for parts, be sure to list the parts no. model no., and description. There are instances in which if any of this information is omitted, parts cannot be shipped or the wrong parts will be delivered.
2. Please be careful not to make a mistake in the parts no. If the parts no. is in error, a part different from the one ordered may be delivered.
3. Because parts number and parts unit supply in the Preliminary Service Manual (Basic Parts List) may be partially changed, please use this parts list for all future reference.

WARNING: Δ INDICATES SAFETY CRITICAL COMPONENTS. FOR CONTINUED SAFETY, REPLACE SAFETY CRITICAL COMPONENTS ONLY WITH MANUFACTURER'S RECOMEMNDED PARTS.

AVERTISSEMENT: Δ IL INDIQU LES COMPOSANTS CRITIQUES DE SURETE. POUR MAINTENIR LE DEGRE DE SECURITE DE L'APPAREIL NE REMPLACER LES COMPOSANTS DONT LE FONCTIONNEMENT EST CRITIQUE POUR LA SECURITE QUE PAR DES PIECES RECOMMANDEES PAR LE FABRICANT.

1. RECOMMENDED SPARE PARTS

Because, if the parts listed below are on hand, almost any repair can be accomplished, we suggest that you stock these Recommended Spare Parts Items.

REF. NO.	PARTS NO.	DESCRIPTION	REF. NO.	PARTS NO.	DESCRIPTION
1-1	BHT1009A320A	HEAD BLK GX-747	1-66	EI330352	IC BA6109
1-2	BMM1101A010A	△ MOTOR SCM-200	1-67	EI319632	IC LB1275
1-3	BM319631	△ MOTOR VA208B01	1-68	EI325755	IC LC7550
1-4	BMM1202A010A	△ MOTOR 24XO-TD	1-69	EI257602	IC MC14011BCP
1-5	BRT1005A110B	REEL TABLE BLK TE (TAKE-UP)	1-70	EI696363	IC MC14049BCP
1-6	BT330329	△ TRANS POWER TTT-1 (U)	1-71	EI213390	IC NJM4558D
1-7	BT330330	△ TRANS POWER TTT-2 (J)	1-72	EI322599	IC TA75458S
1-8	BT330331	△ TRANS POWER TTT-3 (E,B,S,V)	1-73	EI330986	IC TA78L009AP
1-9	BT330332	△ TRANS POWER TTT-4 (C,A)	1-74	EI330985	IC μPD553C-110
1-10	BZT1009A140B	ROLLER TABLE (L) BLK GX-747-BL	1-75	EI330984	IC μPD553C-152
1-11	BZT1009A220A	ROLLER TABLE (R) BLK GX-747	1-76	EJ324276	DIN J TCS4680-01-111 P 8P
1-12	BZT1009A220B	ROLLER TABLE (R) BLK GX-747-BL	1-77	EL324540	PL H LEAD 12V 55mA
1-13	BZT1009A140A	ROLLER TABLE (L) BLK GX-747	1-78	EL317599	PL H LEAD 6.3V 100mA
1-14	ED308953	D GERMA H 1K34A-LH SNP	1-79	EM330992	IND LE SL-1574W CHARACTER
1-15	ED308952	D GERMA V 1K34A-LR F07	1-80	EM330373	IND LE SLA-5401 GRAPH
1-16	ED322982	D GERMA V 1S188FM-1-LR F07	1-81	EM330374	METER VU D64A24L 0.260mA(J)
1-17	ED330996	D LED GL-5HYS YLW	1-82	EM330600	METER VU D64A27L 0.260mA (BL) (J)
1-18	ED330997	D LED GL-5PRS RED	1-83	EP308973	RELAY LEAD LAB2NS 2NO 24V
1-19	ED322247	D LED SLP-151D RED	1-84	EP308949	RELAY POWER FBR211BD024-M 1TR 24V
1-20	ED330995	D LED SLP-260C GRN	1-85	EP324672	RELAY POWER FBR321D012-K 2TR 12V
1-21	ED313566	D SILICON GP-25G 400/2.5A	1-86	EP300132	RELAY POWER MY4-02-US-L 4TR 24V
1-22	ED301911	D SILICON H DS448	1-87	EP330351	RELAY SIGNAL G2KU 1TR 24V
1-23	ED316143	D SILICON H 1S2473HS F10	1-88	EP330363	△ SOLENOID 0730FLT2 29V
1-24	ED330987	D SILICON RB152 200/1.5A	1-89	EP315918	△ SOLENOID 1240PLTI
1-25	ED560913	D SILICON V 1S2473VE	1-90	EP316121	△ SOLENOID 1664PLTI
1-26	ED323979	D SILICON W03B F12 150/1.0A	1-91	ER308955	△ R C T P 20W 360K
1-27	ED306109	D SILICON W03B 100/1.0A	1-92	ER315356	△ R C T P 20W 551K
1-28	ED326168	D SILICON 1D4B1 200/1.5A	1-93	ES330888	△ SW PUSH ESB-70240R 01-1 J (J)
1-29	ED494583	D SILICON 10D05 50/1.0A	1-94	ES330889	△ SW PUSH ESB-70262T 01-1 UC (C,A)
1-30	ED224550	D SILICON 10D4 400/1.0A	1-95	ES330887	△ SW PUSH ESB-70411S 01-1ESBU (U,E,B,S,V)
1-31	ED324669	D SILICON 10D4-FA-2 F12 400/1.0A	1-96	ES319464	SW LEVER 00420460 2-04-02S
1-32	ED324668	D THYRISTOR AC03BGML 200V 3A	1-97	ES319448	SW LEVER 00420461 2-04-02N
1-33	ED324667	D THYRISTOR 2P1M 100V 2A	1-98	ES573478	SW MICRO K3 UC
1-34	ED330989	D ZENER H HZ11 B2	1-99	ES319156	SW MICRO SS-1-E-4 UC
1-35	ED330988	D ZENER H HZ11 C2	1-100	ES326720	SW MICRO VV-S-01
1-36	ED324526	D ZENER H HZ12 C1	1-101	ES330993	SW PUSH SUE-12 2-04-02N
1-37	ED313623	D ZENER H HZ22 3	1-102	ES330372	SW PUSH SUE24 2-THROW
1-38	ED329051	D ZENER H HZ24 3	1-103	ES306714	SW ROTARY SRU1023N 1-02-03N
1-39	ED330962	D ZENER H HZ4 C1	1-104	ES301436	SW SLIDE CL206E 2-06-02S
1-40	ED302295	D ZENER H HZ7 C3	1-105	ES301435	SW SLIDE CL210E 2-10-02S
1-41	ED331185	D ZENER V HZ12 C2	1-106	ES309094	SW SLIDE SL13-6-6-2-2 2-02-02N
1-42	ED319493	THERMISTER ERP-F3A2M471S	1-107	ES315362	SW TACT AKC8S
1-43	EF258344	△ FUSE SEMKO T 250V 0.80A (F3) (E,B,S,V)	1-108	ES323367	SW TACT KEC10001
1-44	EF602550	△ FUSE SEMKO T 250V 1.25A (F2) (E,B,S,V)	1-109	ES319624	SW TACT KEC11903
1-45	EF602550	△ FUSE SEMKO T 250V 1.25A (F6) (E,B,S,V)	1-110	ET324539	TR PHOTO PT-410C C
1-46	EF601964	△ FUSE SEMKO T 250V 1.60A (F7) (E,B,S,V)	1-111	ET554657	TR 2SA733A P,Q
1-47	EF623103	△ FUSE SEMKO T 250V 1A (F4,5) (E,B,S,V)	1-112	ET666415	TR 2SB605 K,L
1-48	EF691007	△ FUSE SEMKO T 250V 3.15A (F1) (U)	1-113	ET318237	TR 2SB764 E,F
1-49	EF691007	△ FUSE SEMKO T 250V 3.15A (F1) (E,B,S,V)	1-114	ET200399	TR 2SB856 B,C
1-50	EF309388	△ FUSE TSC A 250V 0.80A (F3)(J)	1-115	ET375603	TR 2SC1061 B,C
1-51	EF309388	△ FUSE TSC A 250V 0.80A (F3)(U)	1-116	ET517263	TR 2SC1312R G,H
1-52	EF306949	△ FUSE TSC A 250V 1.25A (F6)(U)	1-117	ET603257	TR 2SC1312S G,H
1-53	EF306949	△ FUSE TSC A 250V 1.25A (F6)(J)	1-118	ET308954	TR 2SC1844 E,F
1-54	EF306949	△ FUSE TSC A 250V 1.25A (F2)(J)	1-119	ET308937	TR 2SC2130 G,H
1-55	EF306949	△ FUSE TSC A 250V 1.25A (F2)(U)	1-120	ET311336	TR 2SC2130 H
1-56	EF311839	△ FUSE TSC A 250V 1.6A (F7)(J)	1-121	ET308947	TR 2SC2336B Q,R
1-57	EF311839	△ FUSE TSC A 250V 1.6A (F7)(U)	1-122	ET391768	TR 2SC458LG C,D
1-58	EF309387	△ FUSE TSC A 250V 1A (F4,5)(U)	1-123	ET635220	TR 2SC945L K,P
1-59	EF326639	△ FUSE TSC A 250V 3.15A (F1)(J)	1-124	ET399846	TR 2SC945L Q
1-60	EF309391	△ FUSE TSC 125V 0.08A (F3)(C,A)	1-125	ET639437	TR 2SC945L Q,P
1-61	EF309392	△ FUSE TSC 125V 1.25A (F6) (C,A)	1-126	ET666404	TR 2SD571 K,L
1-62	EF309392	△ FUSE TSC 125V 1.25A (F2)(C,A)	1-127	ET307349	TR 2SD794 P,Q
1-63	EF308847	△ FUSE TSC 125V 1.60A (F7)(C,A)	1-128	ET328440	TR 2SD863-V8 E,F
1-64	EF310229	△ FUSE TSC 125V 1A (F4,5)(C,A)	1-129	EV319625	VR ROTARY 16L10x0Q B102
1-65	EF323080	△ FUSE TSC 125V 3.15A (F1)(C,A)	1-130	EV319494	VR ROTARY 16P11x0U A503 A503
			1-131	EV319316	VR ROTARY 16P20x2A B103
			1-132	EV331189	VR ROTARY 16P20x2B B502
			1-133	EZ324787	PHOTO SENSOR TLP504
			1-134	HEH1305A010A	HEAD E E4-245 O
			1-135	HPH1005A010A	HEAD PB P4-500 O
			1-136	HRH1101A010A	HEAD REC R4-241 O
			1-137	MB331022	ROLLER BELT
			1-138	MTT1003A340A	BRAKE CLOTH ASSY GX-215D

When ordering parts, please quote Parts Number, Description and Model Number.

HEAD BLOCK

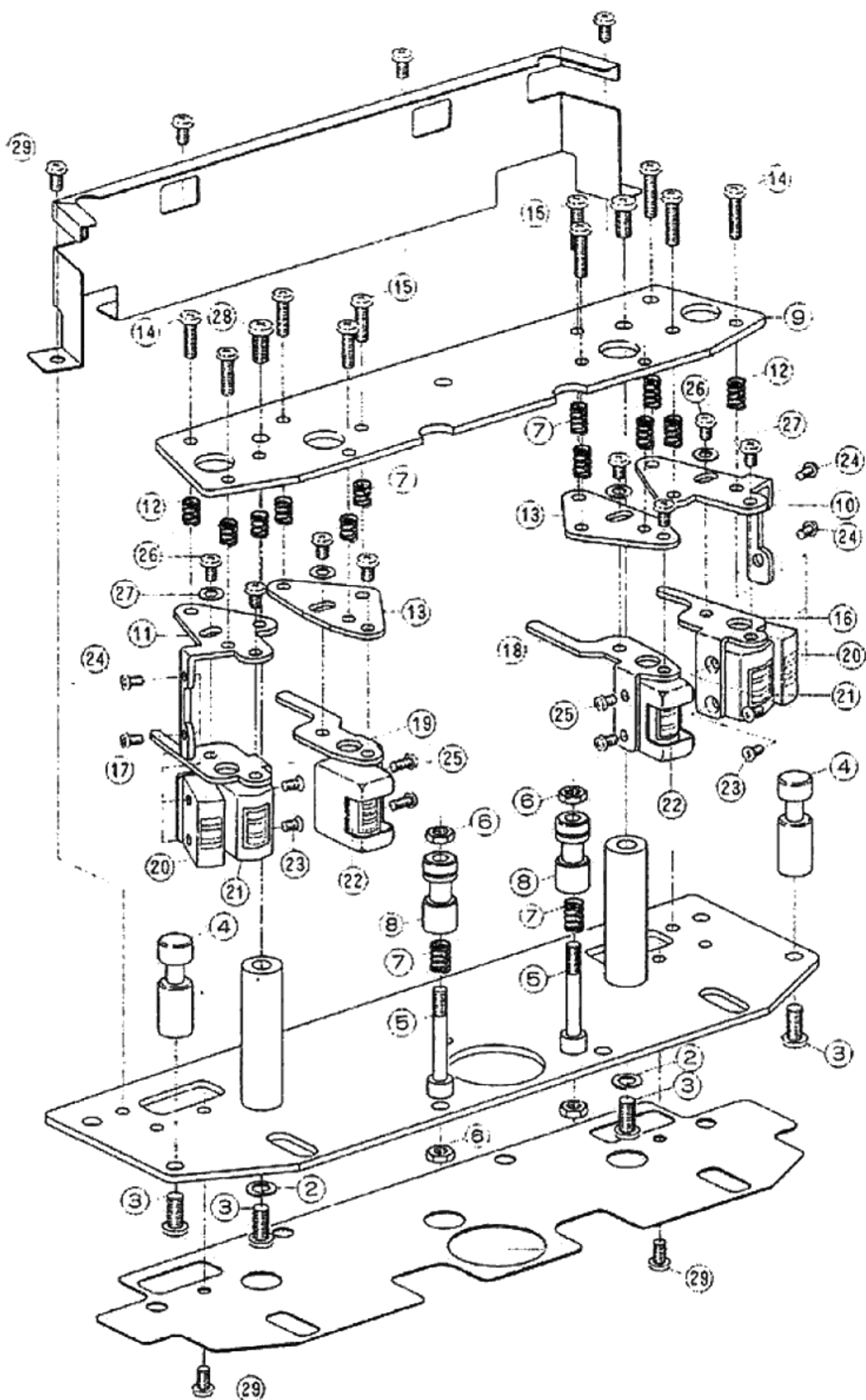

2. HEAD BLOCK

REF. NO.	PARTS NO.	DESCRIPTION	REF. NO.	PARTS NO.	DESCRIPTION
2-1x	BHT1009A320A	HEAD BLK GX-747	2-16	HA309409	ER HEAD ANGLE (A)
2-2	ZW273914	SW40	2-17	HA309410	ER HEAD ANGLE (B)
2-3	ZS413201	PAN40x08STL CMT	2-18	HA330924A	PB HEAD ANGLE (R)
2-4	HZ528581	TAPE GUIDE (A)	2-19	HA330924B	PB HEAD ANGLE (L)
2-5	MH578957	TAPE GUIDE PROP	2-20	HEH1305A010A	HEAD E E4-245 O
2-6	ZW265522	N30BRS NI3 2	2-21	HRH1101A010A	HEAD REC R4-241 O
2-7	ZG466312	ANGLE ADJUST SPRING (E)	2-22	HPH1005A010A	HEAD PB P4-500 O
2-8	HZ301777	TAPE GUIDE (C)	2-23	ZS524812	CTS20x04STL CMT
2-9	HZ308681	HEAD SUB CHASSIS	2-24	ZS477876	PAN20x03STL CMT
2-10	HB331113A	ER HEAD BASE (A)	2-25	ZS608095	PAN20x05STL CMT
2-11	HB331113B	ER HEAD BASE (B)	2-26	ZS608477	PAN30x04STL BNI
2-12	ZG540584	ANGLE ADJUST SPRING (G)	2-27	ZW309055	PW30x060x050STL BNI
2-13	HZ308685	PB HEAD BASE	2-28	ZS201778	PAN40x08STL BNI
2-14	ZS608501	PAN30x12STL BNI	2-29	ZS422076	PAN30x05STL CMT
2-15	ZS417407	PAN30x10STL BNI			

When ordering parts, please quote Parts Number, Description and Model Number.

MOTOR BLOCK

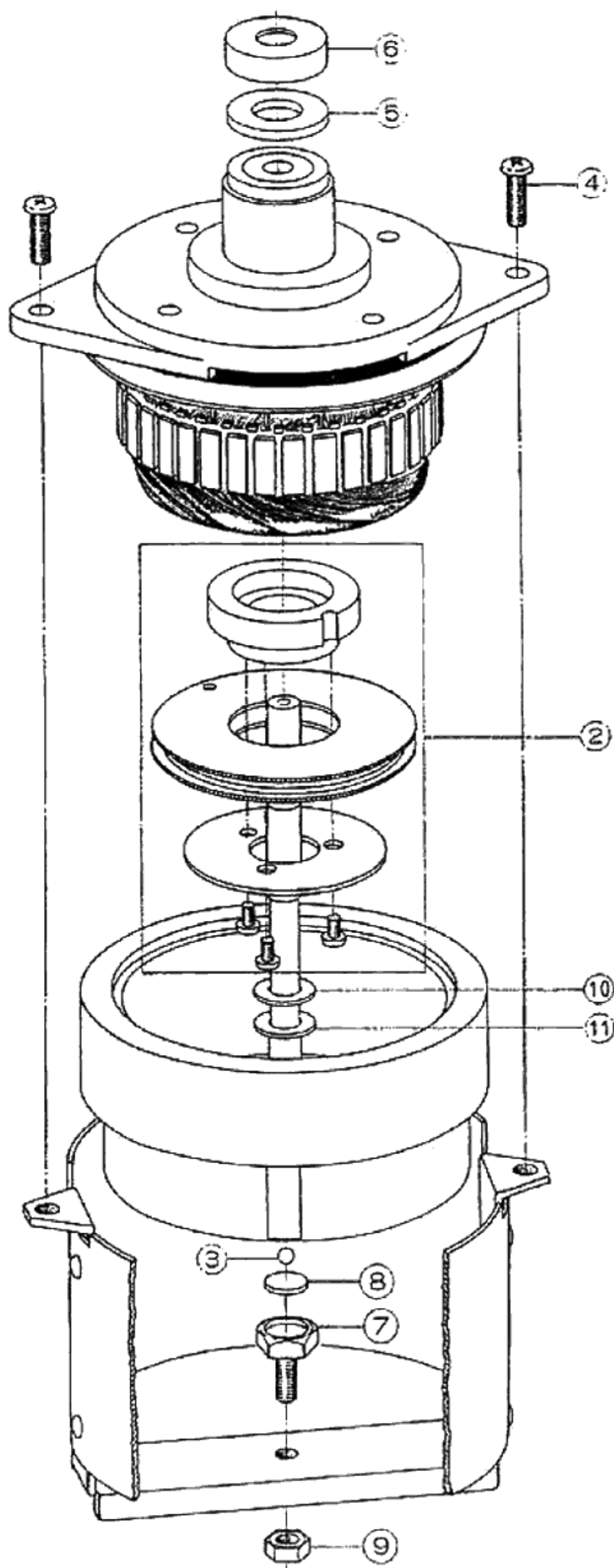

3. MOTOR BLOCK

REF. NO.	PARTS NO.	DESCRIPTION
3-1x	BMM1101A010A	△ MOTOR SCM-200
3-2	BZM1101A040A	DETECTION GEAR BLK SCM-200
3-3	MV368886	BALL 300STL
3-4	ZS413201	PAN40x08STL CMT
3-5	ZW597622	FELT WASHER
3-6	SK597633	CAP
3-7	MZ585900	SHAFT SUPPORT
3-8	MZ597690	BALL HOLDER
3-9	ZW413278	N50STL CMT 1
3-10	ZW597543	THRUST WASHER
3-11	ZW605698	THRUST WASHER (B)

When ordering parts, please quote Parts Number, Description and Model Number.

REEL TABLE BLOCK

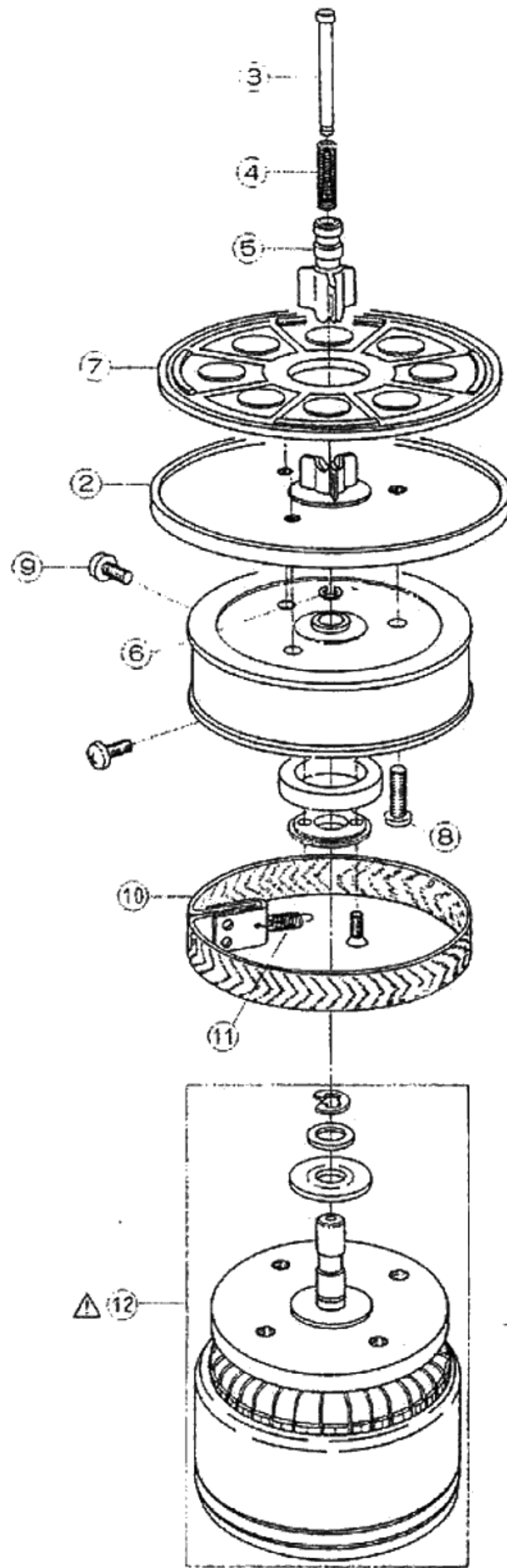

4. REEL TABLE BLOCK

REF. NO.	PARTS NO.	DESCRIPTION
4-1x	BRT1005A110B	REEL TABLE BLK TE(TAKE-UP)
4-2	MT534666	REEL TABLE
4-3	MS342000	REEL SHAFT
4-4	ZG540617	CLAMPER SPRING
4-5	MT534677	REEL CLAMPER
4-6	ZW270088	RING E 190SUP CMT
4-7	MT534688	REEL TABLE RUBBER
4-8	ZS419670	PAN30x12 STL CMT
4-9	ZS424056	PAN40x10 STL CMT
4-10	MTT1003A340A	BRAKE CLOTH ASSY GX-215D
4-11	ZG317496	FELT TENSION SPRING
4-12	BMM1202A010A	△ MOTOR 24XO-TD

ROLLER TABLE (L/R) BLOCK

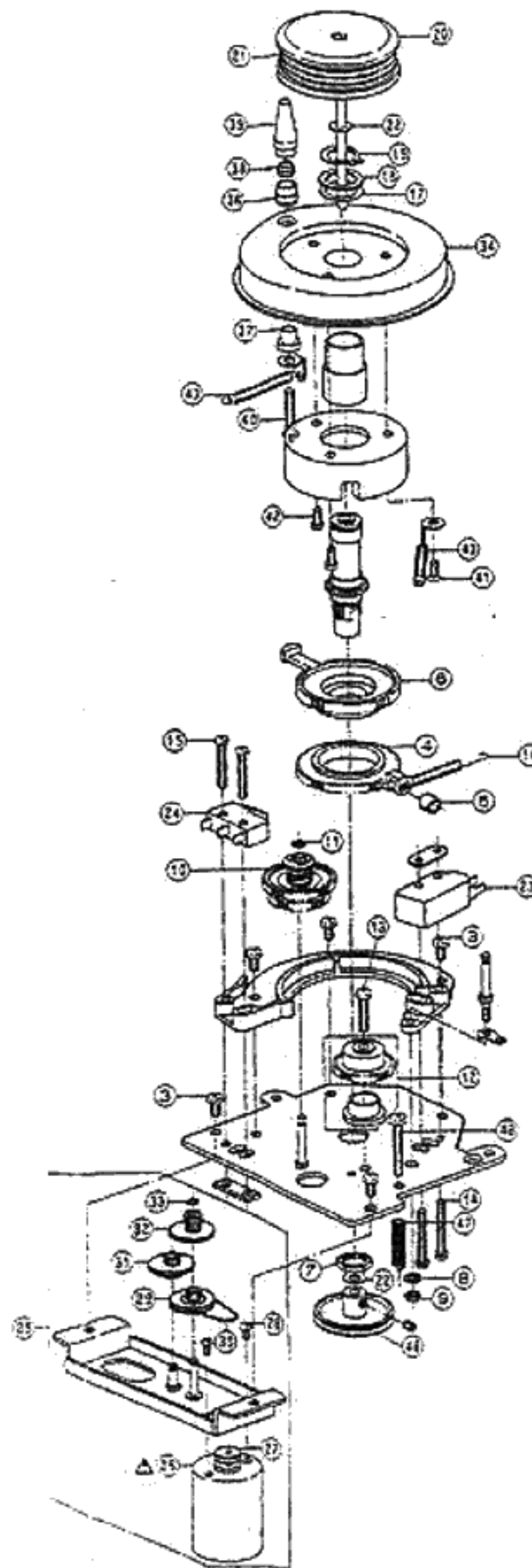
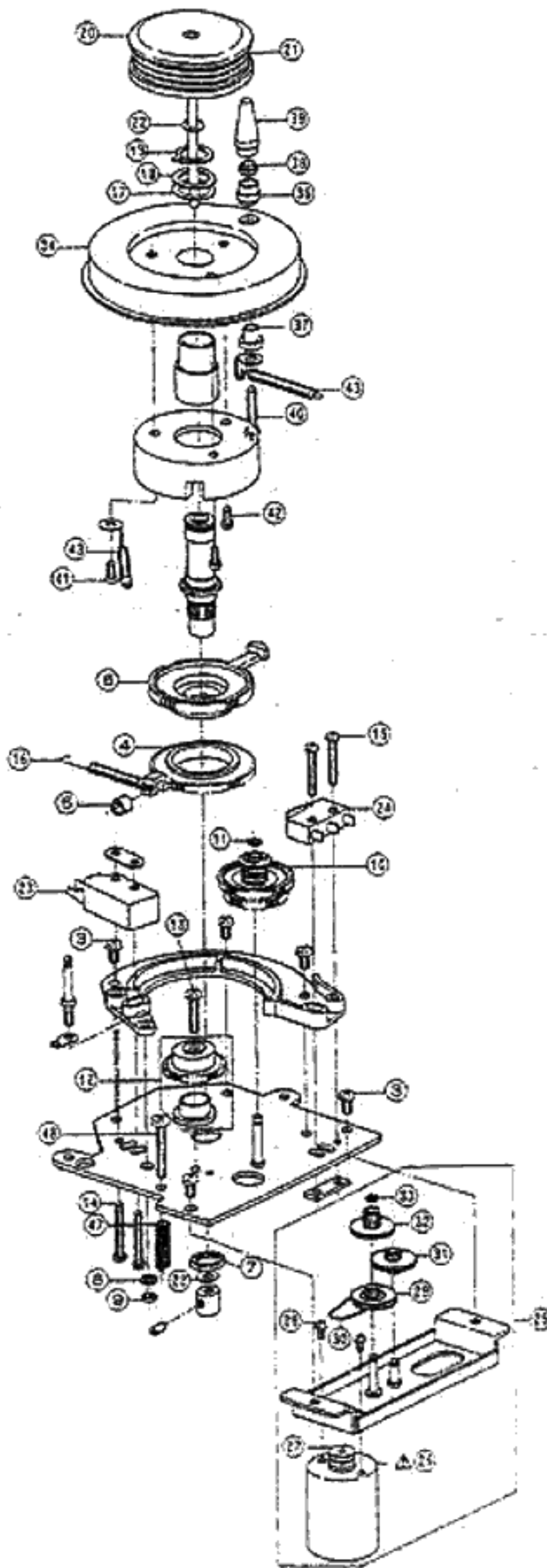

5. ROLLER TABLE (L/R) BLOCK

REF. NO.	PARTS NO.	DESCRIPTION
5-1x	BZT1009A140A	ROLLER TABLE (L) BLK GX-747
5-2x	BZT1009A140B	ROLLER TABLE (L) BLK GX-747-BL
5-3	ZS422076	PAN30x05STL CMT
5-4	ML331001	DAMPER ARM
5-5	S2332462	CUSHION ARM
5-6	ML331000	MOTOR ARM
5-7	ZW318099	NUT M9
5-8	ZW321513	PW26x080x100NYL
5-9	ZW618884	N20STL CMT 1
5-10	BZT1009A150A	CLUTCH BLK GX-747
5-11	ZW321437	PUSH WASHER
5-12	BZT1009A160A	DAMPER BLK GX-747
5-13	ZS419670	PAN30x12STL CMT
5-14	ZS308931	PAN26x18STL CMT
5-15	ZS670004	PAN23x16STL CMT
5-16	ZG567655	AZIMUTH SPRING (1)
5-17	ZW313873	PW105x140x050NYL
5-18	ZW313872	PW105x140x013PSL
5-19	ZW307294	RING C 930SUP PKR
5-20	MR308713	COUNTER ROLLER
5-21	M9331022	ROLLER BELT
5-22	ZW308928	PW24x070x020TFL
MICRO SW (L) BLOCK		
5-23	ES326720	SW MICRO VV-S-01
5-24	ES319156	SW MICRO SS-1-E-4 UC
GEAR BASE BLOCK		
5-25	BZT1009A190A	GEAR BASE BLK GX-747 (1)
5-26	BM319631	△ MOTOR VA208B01
5-27	MR331010	MOTOR PULLEY
5-28	ZS477876	PAN20x03STL CMT
5-29	MZ331006	GEAR (A)
5-30	MB331021	TENSION ARM BELT
5-31	MZ331008	GEAR (B)
5-32	MZ331009	GEAR (C)
5-33	ZW331851	WASHER PUSH 1.6x3.2x0.25 PSL
TENSION WHEEL (L) BLOCK		
5-34	M1308707	TENSION WHEEL
5-35x	M1315558	TENSION WHEEL (BL)
5-36	HZ308710	TAPE GUIDE (B)
5-37	EZ308712	INSULATOR BUSH
5-38	MZ535072	INSULATOR BUSH (A)
5-39	HZ331013	TAPE GUIDE
5-40	ZS422965	PAN30x15STL CMT
5-41	ZS572242	CTS26x06STL CMT
5-42	ZS479474	PAN26x05STL CMT
5-43	ZG312399	SP T1-3.2/0.2-31.5 T1-049
ROLLER TABLE (R) BLOCK		
5-44x	BZT1009A220A	ROLLER TABLE (R) BLK GX-747
5-45x	BZT1009A220B	ROLLER TABLE (R) BLK GX-747-BL
5-46	MR331011	ROLLER PULLEY
5-47	ZG331919	SP ROLLER BASE
5-48	ZS608553	PAN30x20STL CMT

POWER BLOCK

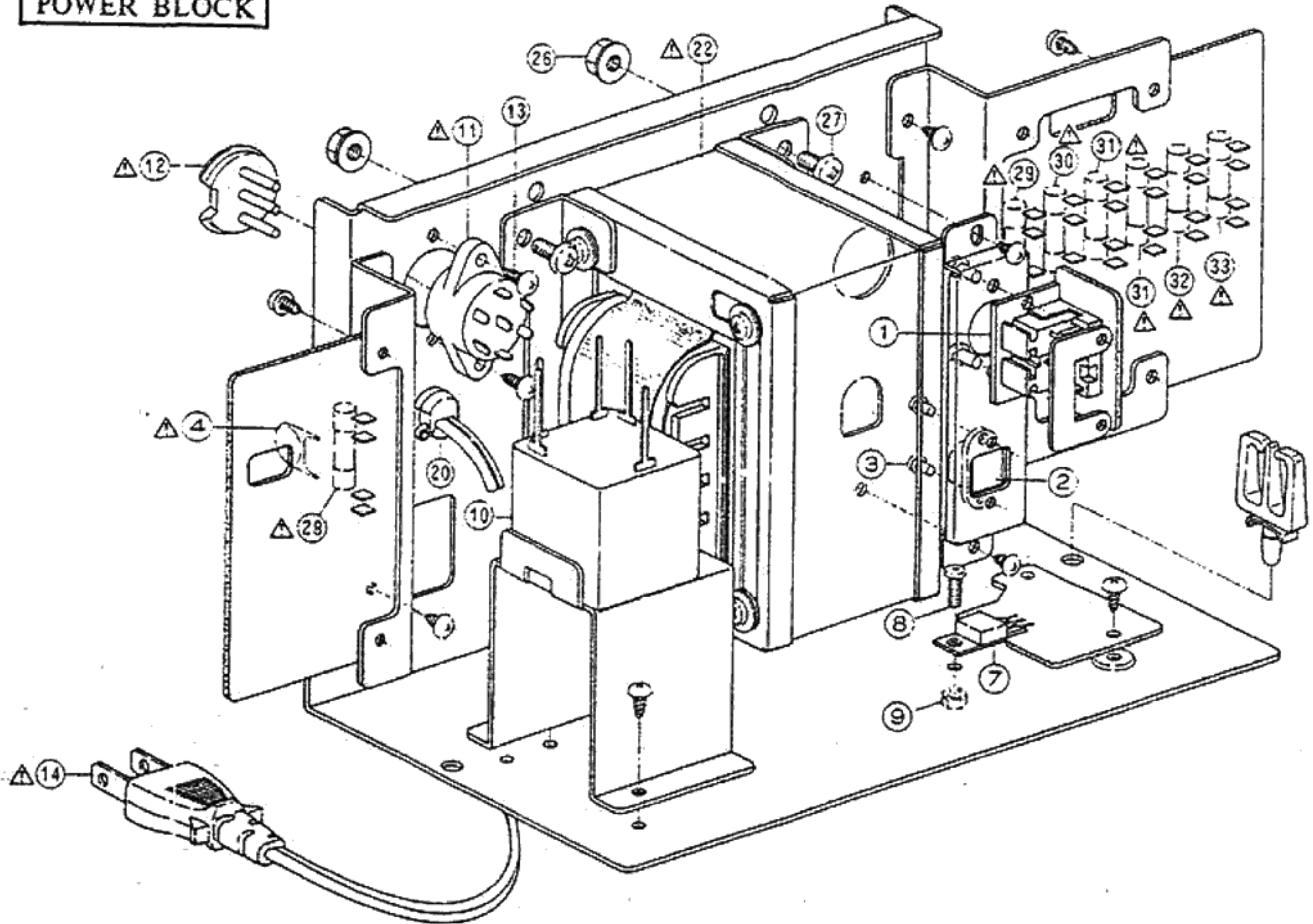

6. POWER BLOCK

REF. NO.	PARTS NO.	DESCRIPTION	REF. NO.	PARTS NO.	DESCRIPTION
6-1	EJ324276	REMO. CON. P.C BOARD BLOCK DIN J TCS4680-01-111 P 8P	6-21x	EJ692908	STRAIN RELIEF SR-5N-4 (B)
6-2	EJ310203	SOCKET BASE BLOCK PLUG CONNECTOR EC0630-020 2P	6-22	BT330329	TRANS POWER TTT-1 (U)
6-3	ZS322839	PAN23x05BRS BNI	6-23x	BT330330	TRANS POWER TTT-2 (J)
6-4	EC320548	FUSE P.C BOARD BLOCK C CE V F 103Z 250AC (U,J)	6-24x	BT330332	TRANS POWER TTT-4 (C,A)
6-5x	EC314688	C CE V FZ 103P 125AC (C,A)	6-25x	BT330331	TRANS POWER TTT-3 (E,B,S,V)
6-6x	EC327382	C MP V 472M 250AC (E,B,S,V)	6-26	ZW413267	N FRANGE 40STL CMT
6-7	ET308947	POWER BLOCK TR 2SC2336B Q,R	6-27	ZS435273	BID40x10STL CMT
6-8	ZS421806	PAN30x08STL CMT	6-28	EF691007	FUSE SEMKO T 250V 3.15A (F1)(U)
6-9	ZW516993	N30STL CMT 1	6-29	EF306949	FUSE TSC A 250V 1.25A (F2)(U)
6-10	EC316065	C MMY V HFV SPECIAL 250AC	6-30	EF309388	FUSE TSC A 250V 0.80A (F3)(U)
6-11	EJ262732	SOCKET SELECTOR S-I7223 U 7P (U)	6-31	EF309387	FUSE TSC A 250V 1A (F4,5)(U)
6-12	EJ249467	PLUG VOLTAGE SELECTOR S-I7207 3P (U)	6-32	EF306949	FUSE TSC A 250V 1.25A (F6)(U)
6-13	ZS463353	T2BR30x08STL BNI	6-33	EF311839	FUSE TSC A 250V 1.6A (F7)(U)
6-14	EW306423	AC CORD 2 CORES KP-205A, VFF UCJ (U)	6-34x	EF326639	FUSE TSC A 250V 3.15A (F1)(J)
6-15x	EW306427	AC CORD 2 CORES KP-211, VFF J (J)	6-35x	EF306949	FUSE TSC A 250V 1.25A
6-16x	EW305691	AC CORD 2 CORES KP-8, SPT-1 UC (C,A)	6-36x	EF309388	FUSE TSC A 250V 0.80A (F3)(J)
6-17x	EW313882	AC CORD 2 CORES KP-419C, LTCE-2F E (E,V)	6-37x	EF306949	FUSE TSC A 250V 1.25A (F6)(J)
6-18x	EW313884	AC CORD 2 CORES GTBS-2F 24/0.20x2 B (B)	6-38x	EF311839	FUSE TSC A 250V 1.6A (F7)(J)
6-19x	EW201515	AC CORD 2 CORES KP-560, LTSA-2F S (S)	6-39x	EF323080	FUSE TSC 125V 3.15A (F1)(C,A)
6-20	SZ631945	STRAIN RELIEF SR-4N-4 (U,J,C,A,E,S,V)	6-40x	EF309392	FUSE TSC 125V 1.25A (F2)(C,A)
			6-41x	EF309391	FUSE TSC 125V 0.08A (F3)(C,A)
			6-42x	EF310229	FUSE TSC 125V 1A (F4,5)(C,A)
			6-43x	EF309392	FUSE TSC 125V 1.25A (F6)(C,A)
			6-44x	EF308847	FUSE TSC 125V 1.60A (F7)(C,A)
			6-45x	EF691007	FUSE SEMKO T 250V 3.15A (F1)(E,B,S,V)
			6-46x	EF602550	FUSE SEMKO T 250V 1.25A (F2)(E,B,S,V)
			6-47x	EF258344	FUSE SEMKO T 250V 0.80A (F3)(E,B,S,V)
			6-48x	EF623103	FUSE SEMKO T 250V 1A (F4,5)(E,B,S,V)
			6-49x	EF602550	FUSE SEMKO T 250V 1.25A (F6)(E,B,S,V)
			6-50x	EF601964	FUSE SEMKO T 250V 1.60A (F7)(E,B,S,V)

When ordering parts, please quote Parts Number, Description and Model Number.

MECHA BLOCK

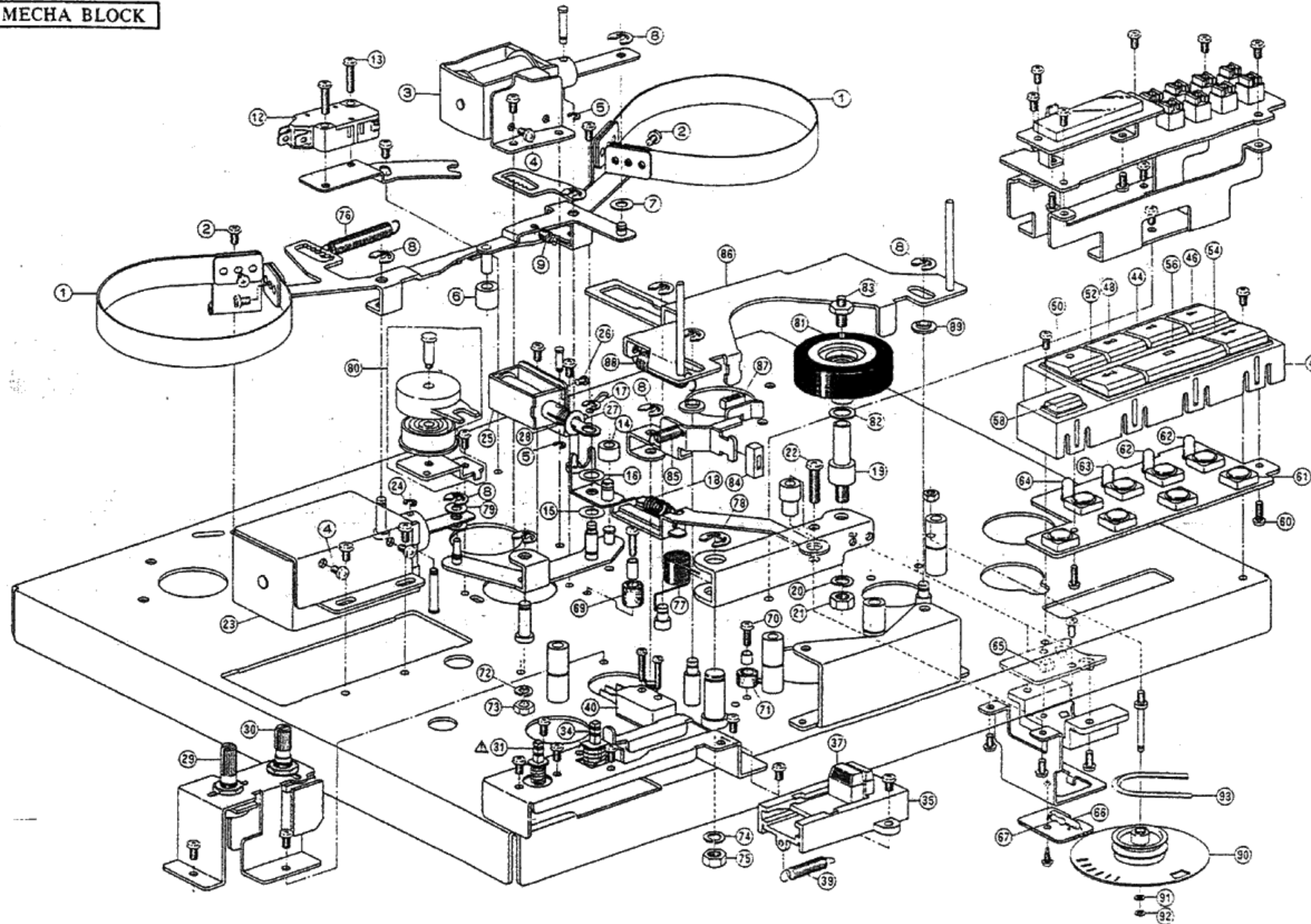

REF. NO.	PARTS NO.	DESCRIPTION
REEL SIZE SW BLOCK		
7-34	ES330993	SW PUSH SUE-12 2-04-02N
SLIDE BOX BLOCK		
7-35	SZ331037A	SLIDE BOX
7-36x	TC331037B	SLIDE BOX (BL)
7-37	TC331038A	CUE SLIDE
7-38x	TC331038B	CUE SLIDE (BL)
7-39	ZG331565	SP T2-5.0/0.32-28.0 T2-144
MICRO SW BLOCK		
7-40	ES326720	SW MICRO VV-S-01
OPERATION BLOCK		
7-41	SE331024A	OPERATE ESCUTCHEON
7-42x	SE331024B	OPERATE ESCUTCHEON (BL)
7-43x	SB331025	OPERATE BUTTON
7-44	SBB603905	OPERATION KEY (A) PART
7-45x	SBB603901	OPERATION KEY (A)-BL PART
7-46	SBB603906	OPERATION KEY (B) PART
7-47x	SBB603902	OPERATION KEY (B)-BL PART
7-48	SBB603907	OPERATION KEY (C) PART
7-49x	SBB603903	OPERATION KEY (C)-BL PART
7-50	SBB603908	OPERATION KEY (F) PART
7-51x	SBB603904	OPERATION KEY (F)-BL PART
7-52	SB331026D	OPERATION KEY (D)
7-53x	SB331026K	OPERATION KEY (D)-BL
7-54	SB331026E	OPERATION KEY (E)
7-55x	SB331026L	OPERATION KEY (E)-BL
7-56	SB331027A	OPERATION KEY (G)
7-57x	SB331027B	OPERATION KEY (G)-BL
7-58	SB331028A	OPERATION KEY (H)
7-59x	SB331028B	OPERATION KEY (H)-BL
7-60	ZS602190	T2BR26x06STL CMT
OPERATION P.C BOARD BLOCK		
7-61	ES315362	SW TACT AKC88
7-62	ED330995	D LED SLP-260C GRN
7-63	ED330996	D LED GL-5HY5 YLW
7-64	ED330997	D LED GL-5PR5 RED
DETECTION (A) P.C BOARD BLOCK		
7-65	ET324539	TR PHOTO PT-410C C
DETECTION (B) P.C BOARD BLOCK		
7-66	EL324540	PL H LEAD 12V 55mA
7-67	ER318248	R FUSE ERD2FC 1/4W 47R0G
MECHA BLOCK		
7-68x	SA312529	RUBBER FOOT (A-2) PART
7-69	MB606712	KJ STOPPER RUBBER
7-70	ZS419670	PAN30x12STL CMT
7-71	MB428343	KD STOPPER RUBBER
7-72	ZW273914	SW40
7-73	ZW413188	N40STL CMT 1
7-74	ZW274026	SW50
7-75	ZW413278	N50STL CMT 1
7-76	ZG313078	SP T1-6.3/0.5-50.0 T1-190
7-77	ZG301340	PINCH ROLLER SPRING
7-78	ZW270156	RING E 600SUP CMT
7-79	ZW420682	PW42x090x050NYL
7-80	BZT1009A080A	PR DAMPER BLK GX-747
7-81	MPB424023	PINCH ROLLER PART KD
7-82	ZW376391	PW61x100x013PSL
7-83	ZS527681	PINCH ROLLER SET SCREW
7-84	MB668301	TE STOPPER RUBBER (B)
7-85	ZG313028	SP T1-5.0/0.32-20.0 T1-141
7-86	MLB330939	SHIFTER SLIDE PART
7-87	VT422673	BRAKE RUBBER BUSH
7-88	ZG317114	TENSION LEVER SPRING
7-89	ZW580173	GUIDE WASHER
7-90	MR330945	DETECTION PULLEY
7-91	ZW305546	PW21x040x025PSL
7-92	ZW321437	PUSH WASHER
7-93	MB330938	DETECTION BELT

7. MECHA BLOCK

REF. NO.	PARTS NO.	DESCRIPTION
BRAKE LEVER BLOCK		
7-1	MT314987	BRAKE BAND
7-2	ZS417216	PAN30x04STL CMT
BRAKE PLUNGER BLOCK		
7-3	EP315918	△ SOLENOID 1240PLTI
7-4	ZS422076	PAN30x05STL CMT
7-5	ZW270088	RING E 190SUP CMT
7-6	MZ397181	LEVER CUSHION
7-7	ZW420682	PW42x090x050NYL
7-8	ZW290283	RING U 285SUP CMT
7-9	ZG580522	CLUTCH LEVER SPRING
7-10x	ZW616004	PW31x080x100STL CMT
7-11x	ZS323728	BID30x05STL CMT

REF. NO.	PARTS NO.	DESCRIPTION
SW PLATE BLOCK		
7-12	ES573478	SW MICRO K3 UC
7-13	ZS419670	PAN30x12STL CMT
P PLUNGER BLOCK		
7-14	MB428343	KD STOPPER RUBBER
7-15	ZW405865	PW51x103x050NYL
7-16	ZW260043	PW61x100x020NYL
7-17	ZW270123	RING E 400SUP CMT
7-18	ZG308728	P SPRING
7-19	MS527591	PINCH ROLLER SHAFT
7-20	ZW274026	SW50
7-21	ZW413278	N50STL CMT 1
7-22	ZS444262	BID40x18STL CMT
PR PLUNGER BLOCK		
7-23	EP316121	△ SOLENOID 1664PLTI
7-24	ZW357164	RING E230SUP CMT

REF. NO.	PARTS NO.	DESCRIPTION
PAUSE PLUNGER BLOCK		
7-25	EP330363	△ SOLENOID 0730FLT2 29V
7-26	ZS592378	PAN26x03STL CMT
7-27	ZW313593	PW51x103x050PBR
7-28	ZG308734	JOINT SPRING
VOLUME BLOCK		
7-29	EV319625	VR ROTARY 16L10x0Q B102
ROTARY SELECTOR BLOCK		
7-30	ES306714	SW ROTARY SRU1023N 1-02-03N
POWER SW BLOCK		
7-31	ES330887	△ SW PUSH ESB-70411S 01-1ESBU (U.E.B.S.V)
7-32x	ES330888	△ SW PUSH ESB-70240R 01-1 J (J)
7-33x	ES330889	△ SW PUSH ESB-70262T 01-1 UC (C.A)

When ordering parts, please quote Parts Number, Description and Model Number.

8. SYS. CON. P.C BOARD BLOCK

REF. NO.	PARTS NO.	DESCRIPTION	REF. NO.	PARTS NO.	DESCRIPTION
8-1	BAT1009A430A	PC SYSCON BLK GX-747 (U)	8-D51	ED330988	D ZENER H HZ11 C2
8-2	BAT1009A430B	PC SYSCON BLK GX-747 (J)	8-D52 to 69	ED560913	D SILICON V 1S2473VE
8-3	BAT1009A430C	PC SYSCON BLK GX-747 (C) (C,A)	8-D70,71	ED306109	D SILICON W03B 100/1.0A
8-4	BAT1009A430D	PC SYSCON BLK GX-747 (E) (E,B,S,V)	8-D72	ED316143	D SILICON H 1S2473HS F10
8-IC1	EI330984	IC μ PD553C-152	8-D73 to 75	ED560913	D SILICON V 1S2473VE
8-IC2	EI330985	IC μ PD553C-110	8-D76,77	ED330989	D ZENER H HZ11 B2 (EXCEPT J)
8-IC3,4	EI696363	IC MC14049BCP	8-D78,79	ED302295	D ZENER H HZ7 C3
8-IC5,6	EI330352	IC BA6109	8-D80	ED308952	D GERMA V 1K34A-LR F07
8-IC7,8	EI257602	IC MC14011BCP	8-D81,82	ED560913	D SILICON V 1S2473VE
8-IC9	EI330986	IC TA78L 009AP (EXCEPT J)	8-D83	ED308952	D GERMA V 1K34A-LR F07
8-TR1	ET639437	Δ TR 2SC945L Q,P	8-D84 to 86	ED560913	D SILICON V 1S2473VE
8-TR2	ET375603	Δ TR 2SC1061 B,C	8-SW1	ES309094	SW SLIDE SL13-6-6-2-2 2-02-02N (U,J)
8-TR3 to 6	ET639437	TR 2SC945L Q,P	8-VR1	EV330980	R S-FIX V V18K3-2 (4US) T3P 503
8-TR7,8	ET554657	TR 2SA733A P,Q	8-VR2	EV330981	R S-FIX V V81K3-2 (4US) T3P 203
8-TR9	ET639437	TR 2SC945L Q,P	8-VR3	EV536117	R S-FIX V V8K1-1 3P 204
8-TR10	ET554657	TR 2SA733A P,Q	8-IFT1,2	EO330353	COIL IFT 12A1295 400KHz
8-TR11	ET639437	TR 2SC945L Q,P	8-SCR1,2	ED324667	Δ D THYRISTOR 2P1M 100V 2A
8-TR12,13	ET375603	Δ TR 2SC1061 B,C	8-SCR3,4	ED324668	Δ D THYRISTOR AC03BGML 200V 3A
8-TR14	ET639437	Δ TR 2SC945L Q,P	8-SR1	ED330361	COMP D 01-0034
8-TR15	ET554657	TR 2SA733A P,Q	8-SR2	ED330362	COMP D 03-0035
8-TR16 to 22	ET639437	TR 2SC945L Q,P	8-SR3,4	ER330356	COMP R 01-0031
8-TR17,18	ET399846	TR 2SC945L Q	8-SR5	ER330355	COMP R 01-0291
8-TR19 to 27	ET311336	TR 2SC2130 H	8-SR6	ER330357	COMP R 01-0292
8-TR20 to 31	ET308937	TR 2SC2130 G,H	8-SR7	ER330358	COMP R 01-0293
8-TR21 to 32	ET328440	Δ TR 2SD863-V8 E,F (EXCEPT J)	8-SR8	ER330359	COMP R 01-0294
8-TR23	ET318237	Δ TR 2SB764 E,F (EXCEPT J)	8-SR9	ER330360	COMP R 01-0295
8-TR24	ET311336	TR 2SC2130 H	8-SR10	ER330354	COMP R 01-0290
8-TR25 to 38	ET639437	TR 2SC945L Q,P	8-RL1 to 4	EP300132	Δ RELAY POWER MY4-02-US-L 4TR 24V
8-TR26 to 40	ET635220	TR 2SC945L K,P	8-RL5	EP324672	RELAY POWER FBR321D012-K 2TR 12V
8-TR27	ET639437	TR 2SC945L Q,P	8-RL6	EP330351	RELAY SIGNAL G2KU 1TR 24V
8-TR28	ET308937	Δ TR 2SC2130 G,H	8-RL7	EP308949	RELAY POWER FBR211BD024-M 1TR 24V
8-TR29,30	ET554657	TR 2SA733A P,Q	8-CR1 to 16	ER300820	SPARK QUENCHER CRU 104C+121R 125AC
8-TR31,32	ET639437	TR 2SC945L Q,P	8-PH1	EZ324787	PHOTO SENSOR TLP504
8-TR33,34	ET666415	TR 2SB605 K,L	8-FR1	ER328520	Δ R FUSE ERD2FC 1/4W 1000G
8-TR35,36	ET666404	TR 2SD571 K,L	8-FR2,3	ER326167	Δ R FUSE 20W 390K
8-TR37,38	ET639437	TR 2SC945L Q,P	8-FR4	ER326169	Δ R FUSE ERD2FC F10 1/4W 22R0G
8-TR39,40	ET311336	TR 2SC2130 H	8-R1,2	ER330976	Δ R OMF H FS 1W 122J (EXCEPT J)
8-TR41,42	ET307349	Δ TR 2SD794 P,Q	8-R26	ER330680	Δ R CB H FS RDS 1/4W 331J
8-TR43 to 65	ET554657	TR 2SA733A P,Q	8-R27	ER330677	Δ R CB H FS RDS 1/4W 181J
8-TR44 to 84	ET635220	TR 2SC945L K,P	8-R30	ER331187	Δ R OMF H FS 1W 272J
8-TR45 to 87	ET554657	TR 2SA733A P,Q	8-R32,33	ER330977	Δ R OMF H FS 2W 680J
8-TR46 to 91	ET639437	TR 2SC945L Q,P	8-R34	ER318430	Δ R OMF H SNP FS 1W 102J
8-TR47 to 96	ET554657	TR 2SA733A P,Q	8-R123	ER315356	Δ R CT P 20W 551K
8-TR48,49	ET639437	TR 2SC945L Q,P	8-R124	ER308955	R CT P 20W 360K
8-TR50,51	ET311336	TR 2SC2130 H	8-R125	ER324670	Δ R OMF H SNP FS 2W 102J
8-TR52,53	ET639437	TR 2SC945L Q,P	8-R131	ER324670	Δ R OMF H SNP FS 2W 102J
8-TR54,55	ET307349	Δ TR 2SD794 P,Q	8-R173	ER330979	Δ R OMF H FS 1W 621J
8-TR56 to 65	ET554657	TR 2SA733A P,Q	8-R214 to 220	ER303342	Δ R OMF H FS 1W 331J
8-TR57 to 84	ET635220	TR 2SC945L K,P	8-C5	EC324662	C EC V CUT SM 222M 25DC
8-TR58 to 87	ET554657	TR 2SA733A P,Q	8-C18	EC316189	C EC V F05 SM 1R0M 100DC
8-TR59 to 91	ET639437	TR 2SC945L Q,P	8-C19	EC310370	C MMY V CUT CME 155K 180AC (EXCEPT J)
8-TR60 to 96	ET554657	TR 2SA733A P,Q	8-C20	EC310368	C MMY V CUT CME 355K 180AC
8-TR61,62	ET639437	TR 2SC945L Q,P	8-C34	EC331243	C EC V TSL 471 160DC
8-TR63,64	ET311336	TR 2SC2130 H	8-C36 to 38	EC316194	C MMY V CUT CF921 474K 250DC
8-TR65,66	ED330987	Δ D SILICON RB152 200/1.5A	8-C54	EC316194	C MMY V CUT CF921 474K 250DC
8-TR67,68	ED326168	Δ D SILICON 1D4B1 200/1.5A	8-C64	EC326583	C MMY V CUT CF921 473K 400DC
8-TR69	ED330987	Δ D SILICON RB152 200/1.5A	8-C100 to 131	EC316191	C MMY V CUT ECQ-E 104K 250DC (E,B,S,V)
8-TR70	ED313566	Δ D SILICON GP-25G 400/2.5A			
8-TR71	ED324526	D ZENER H HZ12 C1			
8-TR72 to 10	ED560913	D SILICON V 1S2473VE			
8-TR73	ED329051	D ZENER H HZ24 3			
8-TR74	ED330988	D ZENER H HZ11 C2			
8-TR75	ED331185	D ZENER V HZ12 C2			
8-TR76	ED560913	D SILICON V 1S2473VE			
8-TR77	ED316143	D SILICON H 1S2473HS F10			
8-TR78	ED560913	D SILICON V 1S2473VE			
8-TR79	ED316143	D SILICON H 1S2473HS F10			
8-TR80 to 27	ED560913	D SILICON V 1S2473VE			
8-TR81,28,29	ED494583	D SILICON 10D05 50/1.0A			
8-TR82,30,31	ED560913	D SILICON V 1S2473VE			
8-TR83 to 35	ED224550	D SILICON 10D4 400/1.0A			
8-TR84,36	ED323979	D SILICON W03B F12 150/1.0A			
8-TR85 to 41	ED324669	Δ D SILICON 10D4-FA-2 F12 400/1.0A			
8-TR86	ED224550	Δ D SILICON 10D4 400/1.0A			
8-TR87,42	ED324669	Δ D SILICON 10D4-FA-2 F12 400/1.0A			
8-TR88,43	ED224550	Δ D SILICON 10D4 400/1.0A			
8-TR89,44	ED322982	D GERMA V 1S188FM-1-LR F07			
8-TR90 to 50	ED560913	D SILICON V 1S2473VE			

9. PRE AMP P.C BOARD BLOCK

REF. NO.	PARTS NO.	DESCRIPTION
9-1	BAT1009A470A	PC PRE AMP BLK GX-747 (U) (U,C,A)
9-2	BAT1009A470B	PC PRE AMP BLK GX-747 (J)
9-3	BAT1009A470D	PC PRE AMP BLK GX-747 (E) (E,B,S,V)
9-IC1	EI213390	IC NJM4558D
9-TR1	ET603257	TR 2SC1312S G,H
9-TR2	ET308954	TR 2SC1844 E,F (E,B,S,V)
9-TR3	ET328440	△ TR 2SD863-V8 E,F
9-TR4,5	ET639437	TR 2SC945L Q,P
9-TR6	ET200399	△ TR 2SB856 B,C
9-TR7	ET517263	△ TR 2SC1312R G,H
9-TR8,9	ET328440	△ TR 2SD863-V8 E,F
9-TR10	ET308954	TR 2SC1844 E,F
9-TR11	ET603257	TR 2SC1312S G,H
9-TR12	ET639437	TR 2SC945L Q,P
9-TR13	ET391768	TR 2SC458LG C,D
9-TR14	ET639437	TR 2SC945L Q,P
9-TR15	ET517263	TR 2SC1312R G,H (J)
9-TR16	ET639437	TR 2SC945L Q,P (J)
9-TR17	ET328440	TR 2SD863-V8 E,F
9-TR18	ET318237	TR 2SB764 E,F
9-TR19 to 23	ET639437	TR 2SC945L Q,P
9-TR24	ET318237	△ TR 2SB764 E,F
9-TR25	ET517263	△ TR 2SC1312R G,H
9-TR26	ET639437	TR 2SC945L Q,P
9-D1 to 3	ED301911	D SILICON H DS448
9-D4,5	ED308953	D GERMA H 1K34A-LH SNP (J)
9-D6	ED301911	D SILICON H DS448
9-D7,8	ED316143	D SILICON H 1S2473HS F10
9-D9	ED301911	D SILICON H DS448
9-D10	ED316143	D SILICON H 1S2473HS F10
9-D11	ED301911	D SILICON H DS448
9-D12	ED316143	D SILICON H 1S2473HS F10
9-D14,15	ED301911	D SILICON H DS448
9-D16	ED313623	D ZENER H HZ22 3
9-D17 to 21	ED301911	D SILICON H DS448
9-VC1,2	EO330991	C S-FIX H ECR-BC090M11 8.0-90
9-J1	EJ308986	PIN J 1784P1782 P 4P (U,J,C,A)
9-J1	EJ308985	JACK PLATE DIN, PIN JACK 4P (E,B,S,V)
9-J2	EJ331184	PHONE J HLJ0345-100 2x2P (U,J,C,A)
9-J2	EJ321328	PHONE J HLJ0345-010 2x3P (E,B,S,V)
9-J3	EJ330545	PHONE J3P HLJ0315-020 6.3
9-SW1	ES301435	SW SLIDE CL210E 2-10-02S
9-SW2	ES330372	SW PUSH SUE24 2-THROW
9-SW3,4	ES319464	SW LEVER 00420460 2-04-02S
9-SW5	ES319448	SW LEVER 00420461 2-04-02N
9-SW6	ES306714	SW ROTARY SRU1023N 1-02-03N
9-SW7	ES301436	SW SLIDE CL206E 2-06-02S
9-VR1 to 3	EV315753	R S-FIX H D8 3P 203
9-VR4	EV315542	R S-FIX H D8 3P 103
9-VR5,6	EV315541	R S-FIX H D8 3P 503
9-VR7	EV319316	VR ROTARY 16P20x2A B103
9-VR8	EV316442	R S-FIX H D8 3P 102 (J)
9-VR9	EV322417	R S-FIX H D8 3P 303
9-RL1,2	EP308973	RELAY LEAD LAB2NS 2NO 24V
9-VL1	EO319495	COIL VARI GYD-102 1MH
9-FL1	EO315758	COIL TUN 1 100S-431 100KHz
9-FL2	EO319447	COIL TUN1 GYD-100K 100KHz
9-FL3	EO331190	COIL OSC 1 2330-065 100KHz
9-FL4,5	EO330990	COIL FIX 2 0358-042 510μH
9-FR1	ER308898	△ R FUSE FR25SJ 1/4W 101J
9-FR2,3	ER331188	△ R FUSE ERD2FC F10 1/4W 8R2J
9-R7	ER331562	△ R OMF H SNP FS 1W 471J
9-C20	EC325380	C PP V F10 PFH 332J 630DC
9-C24	EC310440	C STY V F05 CQF09 471J 50DC
9-C29,30	EC314990	C STY V SNP CQFS 101J 50DC
9-C55	EC314995	C STY V SNP CQFS 331J 50DC

10. MIC AMP P.C BOARD BLOCK

REF. NO.	PARTS NO.	DESCRIPTION
		MIC AMP P.C BOARD BLOCK
10-1	BAT1009A500A	PC MIC AMP BLK GX-747 (U) (U,J,C,A)
10-2	BAT1009A500B	PC MIC AMP BLK GX-747(E) (E,B,S,V)
10-TR1	ET308954	TR 2SC1844 E,F
10-TR2	ET603257	TR 2SC1312S G,H
10-TR3	ET308954	TR 2SC1844 E,F
10-TR4,5	ET639437	TR 2SC945L Q,P
10-VR1,2	EV319494	VR ROTARY 16P11x0U A503 A503
10-FL1	EO319447	COIL TUN1 GYD-100K 100KHz
10-C1	EC312012	C STY V F05 CQF09 561J 50DC
10-C3	EC314995	C STY V SNP CQFS 331J 50DC
10-C4	EC474671	C MC V FM 100K 500DC
10-C6	EC317918	C TT V D 2R2K 16DC
10-C9	EC474671	C MC V FM 100K 500DC
		BIAS ADJ P.C BOARD BLOCK
10-VR1	EV331189	VR ROTARY 16P20x2B B502

11. BAR METER P.C BOARD BLOCK

REF. NO.	PARTS NO.	DESCRIPTION
11-1	BAT1009A520A	PC BAR METER BLK GX-747 (U)
11-IC1 to 7	EI319632	IC LB1275
11-IC8	EI325755	IC LC7550
11-IC9 to 13	EI322599	IC TA75458S
11-D1 to 3	ED560913	D SILICON V 1S2473VE
11-D4	ED330962	D ZENER H HZ4 C1
11-TH1	ED319493	THERMISTER ERP- F3A2M471S
11-VR1	EV330970	R S-FIX V V18K3-2(4US) T3P 104
11-VR2	EV475470	R S-FIX V V8K1-1 3P 103
11-C3	EC331183	C STY V SNP CQFS 102J 50DC
11-IN901	EM330375	IND LE SLA-5401 GRAPH

12. COUNTER P.C BOARD BLOCK

REF. NO.	PARTS NO.	DESCRIPTION
12-D1 to 6	ED316143	D SILICON H 1S2473HS F10
12-D7	ED322247	D LED SLP-151D RED
12-IN1	EM330992	IND LE SL-1574W CHARACTER
12-SW1 to 4	ES319624	SW TACT KEC11903
12-SW5 to 8	ES323367	SW TACT KEC10001

ASSEMBLY BLOCK

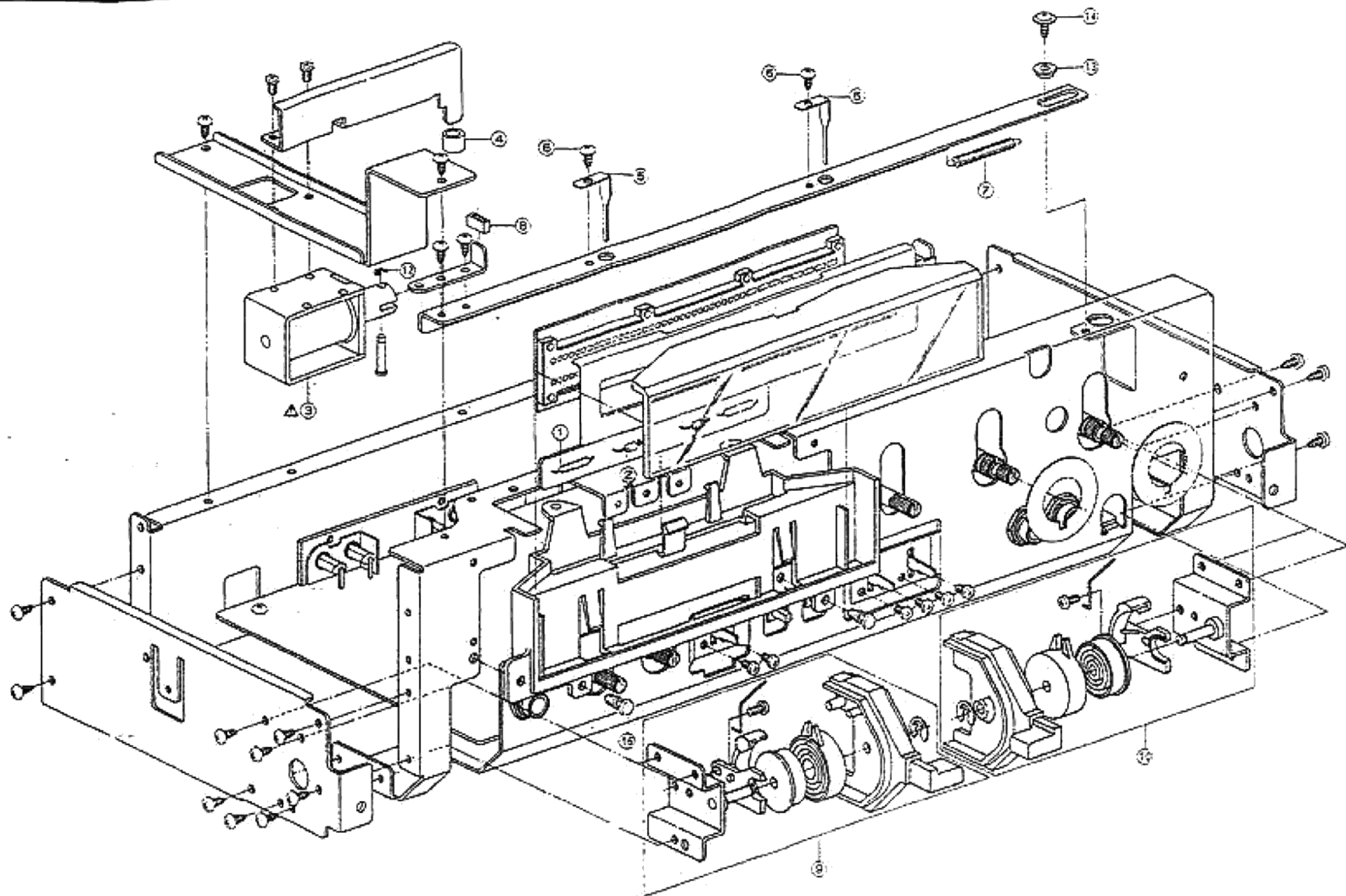

13. ASSEMBLY BLOCK

REF. NO.	PARTS NO.	DESCRIPTION
LAMP P.C BOARD BLOCK		
13-1	EL317599	PL H LEAD 5.3V 100mA (EN1.2)
13-2	ED323979	O SILICON W03S P12 150/1.0A (D1.2)
REVERSE PLUNGER BLOCK		
13-3	EZ315918	Δ SOLENOID 1140PLT1
13-4	M8606712	KJ STOPPER RUBBER
REVERSE ARM BLOCK		
13-5	ZG331069	SP REVERSE

REF NO.	PARTS NO.	DESCRIPTION
13-6	ZS325495	T2BR30x06STL CMT
13-7	ZG313004	SP T1-4.0/0.4-35.5 T1-113
13-8	VT422673	BRAKE RUBBER BUSH
ASSEMBLY BLOCK		
13-9	BZT1009A450A	HINGE BASE (L) BLK GX-74*
13-10	BZT1009A460A	HINGE BASE (R) BLK GX-74*
13-11x	ZW263946	RV NYL46x050
13-12	ZW270088	RING E 190SUP CMT
13-13	TC331070	COLLER
13-14	ZS331566	PAN30x08STL CMT CUP
13-15x	TC310497	MASK (B)
13-16	ZW260370	RV NYL38x052 BL

When ordering parts, please quote Parts Number, Description and Model Number.

INDEX

PARTS NO.	REF. NO.	PARTS NO.	REF. NO.	PARTS NO.	REF. NO.	PARTS NO.	REF. NO.	PARTS NO.	REF. NO.
BAT1009A430A	8-1	ED319493	11-TH1	EL324540	7-66	ET311336	8-TR99	HPH1005A010A	2-22
BAT1009A430B	8-2	ED322247	12-D7	EM330373	11-IN901	ET318237	8-TR33	HRH101A010A	2-21
BAT1009A430C	8-3	ED322982	8-D45,46	EM330374	14-3x	ET318237	9-TR18	HZ301777	2-8
BAT1009A430D	8-4	ED323979	8-D36	EM330600	14-4x	ET318237	9-TR24	HZ308681	2-9
BAT1009A470A	9-1	ED323979	13-2	EM330992	12-IN1	ET324539	7-65	HZ308685	2-13
BAT1009A470B	9-2	ED324526	8-D7	EO315758	9-FL1	ET328440	8-TR32	HZ308710	5-36
EAT1009A470D	9-3	ED324667	8-SCR1,2	EO319447	9-FL2	ET328440	9-TR3	HZ331013	5-39
BAT1009A500A	10-1	ED324668	8-SCR3,4	EO319447	10-FL1	ET328440	9-TR8,9	HZ528581	2-4
BAT1009A500B	10-2	ED324669	8-D37to41	EO319495	9-VL1	ET328440	9-TR17	MB330938	7-93
BAT1009A520A	11-1	ED324669	8-D43	EO330353	8-IFT1,2	ET375603	8-TR12,13	MB331021	5-30
BCB603211	14-54	ED326168	8-D3,4	EO330990	9-FL4,5	ET375603	8-TR2	MB331022	5-21
BCB603212	14-55x	ED329051	8-D11	EO331190	9-FL3	ET391768	9-TR13	MB428343	7-14
BDT1009A540A	14-1	ED330361	8-SR1	EP300132	8-RL1to4	ET399846	8-TR23	MB428343	7-71
BDT1009A540B	14-2x	ED330362	8-SR2	EP308949	8-RL7	ET517263	9-TR7	MB606712	7-69
BHT1009A320A	2-1x	ED330962	11-D4	EP308973	9-RL1,2	ET517263	9-TR15	MB606712	13-4
BMM1101A010A	3-1x	ED330987	8-D5	EP315918	7-3	ET517263	9-TR25	MB668801	7-84
BMM1202A010A	4-12	ED330987	8-D1,2	EP315918	13-3	ET554657	8-TR7,8	MH578957	2-5
BM319631	5-26	ED330988	8-D12	EP316121	7-23	ET554657	8-TR10	MI308707	5-34
BRT1005A110B	4-1x	ED330988	8-D51	EP324672	8-RL5	ET554657	8-TR15	MI315558	5-35x
BT330329		ED330989	8-D76,77	EP330351	8-RL6	ET554657	8-TR43,44	MLB330939	7-86
BT330330	6-23x	ED330995	7-62	EP330363	7-25	ET554657	8-TR58to65	ML328683	14-7
BT330331	6-25x	ED330996	7-63	ER281338	14-5x	ET554657	8-TR85to87	ML331000	5-6
BT330332	6-24x	ED330997	7-64	ER300820	8-CR1to16	ET554657	8-TR93to96	ML331001	5-4
BZM1101A040A	3-2	ED331185	8-D13	ER303342	8-R21to220	ET603257	9-TR1	MPB424023	7-81
BZT1009A080A	7-80	ED494583	8-D28,29	ER308898	9-FR1	ET603257	9-TR11	MR308713	5-20
BZT1009A140A	5-1x	ED560913	8-D8to10	ER308955	8-R124	ET603257	10-TR2	MR330945	7-90
BZT1009A140B	5-2x	ED560913	8-D14	ER315356	8-R123	ET635220	8-TR39,40	MR331010	5-27
BZT1009A150A	5-10	ED560913	8-D16	ER318248	7-67	ET635220	8-TR66to84	MR331011	5-46
BZT1009A160A	5-12	ED560913	8-D18to27	ER318430	8-R34	ET639437	8-TR3to6	MS342000	4-3
BZT1009A190A	5-25	ED560913	8-D30,31	ER324670	8-R125	ET639437	8-TR9	MS527591	7-19
BZT1009A220A	5-44x	ED560913	8-D47to50	ER324670	8-R131	ET639437	8-TR11	MTT1003A340A	4-10
BZT1009A220B	5-45x	ED560913	8-D52to69	ER326167	8-FR2,3	ET639437	8-TR14	MT314987	7-1
BZT1009A450A	13-9	ED560913	8-D73to75	ER326169	8-FR4	ET639437	8-TR16to22	MT534666	4-2
BZT1009A460A	13-10	ED560913	8-D81,82	ER328520	8-FR1	ET639437	8-TR35to38	MT534677	4-5
EC310368	8-C20	ED560913	8-D84to86	ER330354	8-SR10	ET639437	8-TR41	MT534688	4-7
EC310370	8-C19	ED560913	11-D1to3	ER330355	8-SR5	ET639437	8-TR45,46	MT534688	3-3
EC310440	9-C24	EF258344	6-47x	ER330356	8-SR3,4	ET639437	8-TR51,52	MV368886	5-29
EC312012	10-C1	EF306949	6-29	ER330357	8-SR6	ET639437	8-TR54,55	MZ331006	5-31
EC314688	6-5x	EF306949	6-32	ER330358	8-SR7	ET639437	8-TR89to91	MZ331008	5-32
EC314990	9-C29,30	EF306949	6-35x	ER330359	8-SR8	ET639437	8-TR97,98	MZ331009	5-32
EC314995	9-C55	EF306949	6-37x	ER330360	8-SR9	ET639437	8-TR1	MZ331011	7-6
EC314995	10-C3	EF308847	6-44x	ER330677	8-R27	ET639437	8-TR1	MZ535072	5-38
EC316065	6-10	EF309387	6-31	ER330680	8-R26	ET639437	9-TR4,5	MZ585900	3-7
EC316189	8-C18	EF309388	6-30	ER330976	8-R1,2	ET639437	9-TR12	MZ597690	3-8
EC316191	8-C10to131	EF309388	6-36x	ER330977	8-R1,2	ET639437	9-TR14	SAB331097	14-19
EC316194	8-C36to38	EF309388	6-41x	ER330977	8-R32,33	ET639437	9-TR16	SAB331098	14-21
EC316194	8-C54	EF309391	6-40x	ER330979	8-R173	ET639437	9-TR19to23	SA312529	7-68x
EC317918	10-C6	EF309392	6-43x	ER331187	8-R30	ET639437	9-TR26	SBB603901	7-45x
EC320548	6-4	EF310229	6-42x	ER331188	9-FR2,3	ET639437	10-TR4,5	SBB603902	7-47x
EC324662	8-C5	EF311839	6-33	ER331562	9-R7	ET666404	8-TR49,50	SBB603903	7-49x
EC325380	9-C20	EF311839	6-38x	ES301435	9-SW1	ET666415	8-TR47,48	SBB603904	7-51x
EC326583	8-C64	EF323080	6-39x	ES301436	9-SW7	EV315541	9-VR5,6	SBB603905	7-44
EC327382	6-6x	EF326639	6-34x	ES306714	7-30	EV315542	9-VR4	SBB603906	7-46
EC331183	11-C3	EF601964	6-50x	ES306714	9-SW6	EV315753	9-VR1to3	SBB603907	7-48
EC331243	8-C34	EF602550	6-46x	ES309094	8-SW1	EV316442	9-VR8	SBB603908	7-50
EC474671	10-C4	EF602550	6-49x	ES315362	7-61	EV319316	9-VR7	SB315834	14-42
EC474671	10-C9	EF623103	6-48x	ES319156	5-24	EV319494	10-VR1,2	SB315835	14-43x
ED224550	8-D32to35	EF691007	6-28	ES319448	9-SW5	EV319625	7-29	SB315835	14-48
ED224550	8-D42	EF691007	6-45x	ES319464	9-SW3,4	EV322417	9-VR9	SB331025	7-43x
ED224550	8-D44	EI213390	9-IC1	ES319624	12-SW1to4	EV330970	11-VR1	SB331026D	7-52
ED301911	9-D1to3	EI257602	8-IC7,8	ES323367	12-SW5to8	EV330980	8-VR1	SB331026E	7-54
ED301911	9-D6	EI319632	11-IC1to7	ES326720	5-23	EV330981	8-VR2	SB331026K	7-53x
ED301911	9-D9	EI322599	11-IC9to13	ES326720	7-40	EV331189	10-VR1	SB331026L	7-55x
ED301911	9-D11	EI325755	11-IC8	ES330372	9-SW2	EV475470	11-VR2	SB331027A	7-56
ED301911	9-D14,15	EI330352	8-IC5,6	ES330887	7-31	EV536117	8-VR3	SB331027B	7-57x
ED301911	9-D17to21	EI330984	8-IC1	ES330888	7-32x	EW201515	6-19x	SB331028A	7-58
ED302295	8-D78,79	EI330985	8-IC2	ES330889	7-33x	EW305691	6-16x	SB331028B	7-59x
ED306109	8-D70,71	EI330986	8-IC9	ES330993	7-34	EW306427	6-15x	SB331137A	14-40
ED308952	8-D80	EI696363	8-IC3,4	ES573478	7-12	EW306428	6-14	SCB331082A	14-33
ED308952	8-D83	EJ249467	6-12	ET200399	9-TR6	EW313882	6-17x	SCB331082B	14-34x
ED308953	9-D4,5	EJ262732	6-11	ET307349	8-TR57	EW313884	6-18x	SCB603208	14-36
ED313566	8-D6	EJ308985	9-J1	ET308937	8-TR28to31	EZ308712	5-37	SCB603209	14-37x
ED313623	9-D16	EJ308986	9-J1	ET308937	8-TR42	EZ324787	8-PH1	SE331024A	7-41
ED316143	8-D15	EJ310203	6-2	ET308947	6-7	EO330991	9-VCL1,2	SE331024B	7-42x
ED316143	8-D17	EJ321328	9-J2	ET308954	9-TR2	HA309409	2-16	SKB331101	14-53
ED316143	8-D72	EJ324276	6-1	ET308954	9-TR10	HA309410	2-17	SKB601364	14-44
ED316143	9-D7,8	EJ330545	9-J3	ET308954	10-TR1	HA330924A	2-18	SKB601365	14-45x
ED316143	9-D10	EJ331184	9-J2	ET308954	10-TR3	HA330924B	2-19	SKB603210	14-50
ED316143	9-D12	EJ692908	6-21x	ET311336	8-TR24to27	HB331113A	2-10	SK328684	14-6
ED316143	12-D1to6	EL317599	13-1	ET311336	8-TR34	HB331113B	2-11	SK331100	14-52
				ET311336	8-TR53	HEH1305A010A	2-20	SK331108A	14-46

PARTS NO.	REF. NO.	PARTS NO.	REF. NO.	PARTS NO.	REF. NO.	PARTS NO.	REF. NO.	PARTS NO.	REF. NO.
SK331108B	14-49	ZS435273	6-27						
SK331109A	14-38	ZS435273	14-20x						
SK331109B	14-39x	ZS444262	7-22						
SK331109C	14-47	ZS447761	14-18x						
SK331137B	14-41x	ZS447761	14-22x						
SK597633	3-6	ZS463353	6-13						
SPB603205	14-12	ZS477876	2-24						
SPB603206	14-27	ZS477876	5-28						
SPB603207	14-28x	ZS479474	5-42						
SPB603214	14-14x	ZS524812	2-23						
SPB603215	14-13x	ZS527681	7-83						
SPB603216	14-15x	ZS559056	14-57x						
SP304933A	14-8	ZS572242	5-41						
SP304933B	14-9x	ZS592378	7-26						
SP305022	14-25x	ZS602190	7-60						
SP308805	14-23	ZS608095	2-25						
SP315587	14-24x	ZS608253	5-48						
SP331076A	14-16x	ZS608477	2-26						
SP331076B	14-17x	ZS608501	2-14						
SP331078A	14-58x	ZS613901	14-31						
SP331078B	14-59x	ZS670004	5-15						
SP331078C	14-60x	ZW260043	7-16						
SP331078D	14-61x	ZW260370	13-16						
SP331078E	14-62x	ZW263946	13-11x						
SZ331037A	7-35	ZW265522	2-6						
SZ332462	5-5	ZW270088	4-6						
SZ631945	6-20	ZW270088	7-5						
TC310497	13-15x	ZW270088	13-12						
TC331037B	7-36x	ZW270123	7-17						
TC331038A	7-37	ZW270156	7-78						
TC331038B	7-38x	ZW273914	2-2						
TC331070	13-13	ZW273914	7-72						
TC331104	14-51x	ZW274026	7-20						
TC331106A	14-29	ZW274026	7-74						
VT422673	7-87	ZW290283	7-8						
VT422673	13-8	ZW305013	14-64x						
ZG301340	7-77	ZW305546	7-91						
ZG308728	7-18	ZW307294	5-19						
ZG308734	7-28	ZW308928	5-22						
ZG312399	5-43	ZW309055	2-27						
ZG313004	13-7	ZW313593	7-27						
ZG313028	7-85	ZW313872	5-18						
ZG313078	7-76	ZW313873	5-17						
ZG317114	7-88	ZW318099	5-7						
ZG317496	4-11	ZW321437	5-11						
ZG331019	5-47	ZW321437	7-92						
ZG331069	13-5	ZW321513	5-8						
ZG331565	7-39	ZW331106B	14-30x						
ZG466312	2-7	ZW331851	5-33						
ZG540584	2-12	ZW357164	7-24						
ZG540617	4-4	ZW376391	7-82						
ZG567685	5-16	ZW405865	7-15						
ZG580522	7-9	ZW413188	7-73						
ZS200417	14-56x	ZW413267	6-26						
ZS201778	2-28	ZW413278	3-9						
ZS306435	14-32x	ZW413278	7-21						
ZS308931	5-14	ZW413278	7-75						
ZS318423	14-26x	ZW420682	7-7						
ZS322839	6-3	ZW420682	7-79						
ZS323728	7-11x	ZW516993	6-9						
ZS325495	13-6	ZW580173	7-89						
ZS331181	14-10	ZW597543	3-10						
ZS331182	14-11x	ZW597622	3-5						
ZS331566	13-14	ZW605698	3-11						
ZS331568	14-65x	ZW616004	7-10x						
ZS413201	2-3	ZW618884	5-9						
ZS413201	3-4								
ZS417216	7-2								
ZS417407	2-15								
ZS419670	4-8								
ZS419670	5-13								
ZS419670	7-13								
ZS419670	7-70								
ZS421806	6-8								
ZS422076	2-29								
ZS422076	5-3								
ZS422076	7-4								
ZS422965	5-40								
ZS422965	14-35x								
ZS424056	4-9								

SCHEMATIC DIAGRAM

1. SCHEMATIC DIAGRAM OF ICs
2. GX-747 No. 2-1 1621824A SYSCON SCHEMATIC DIAGRAM
3. GX-747 No. 2-2 1621825A AMP SCHEMATIC DIAGRAM

BA6109

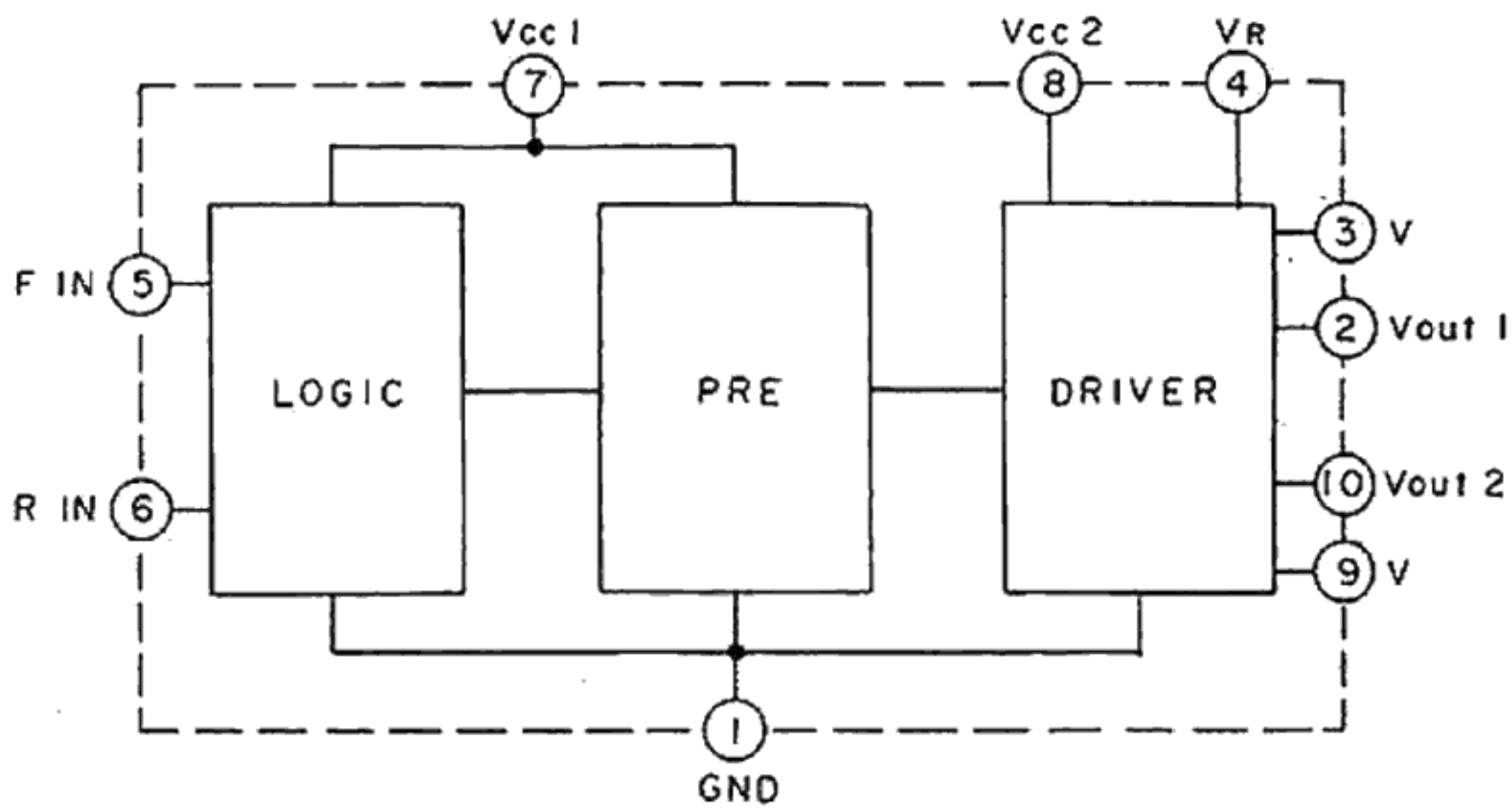

LB1275

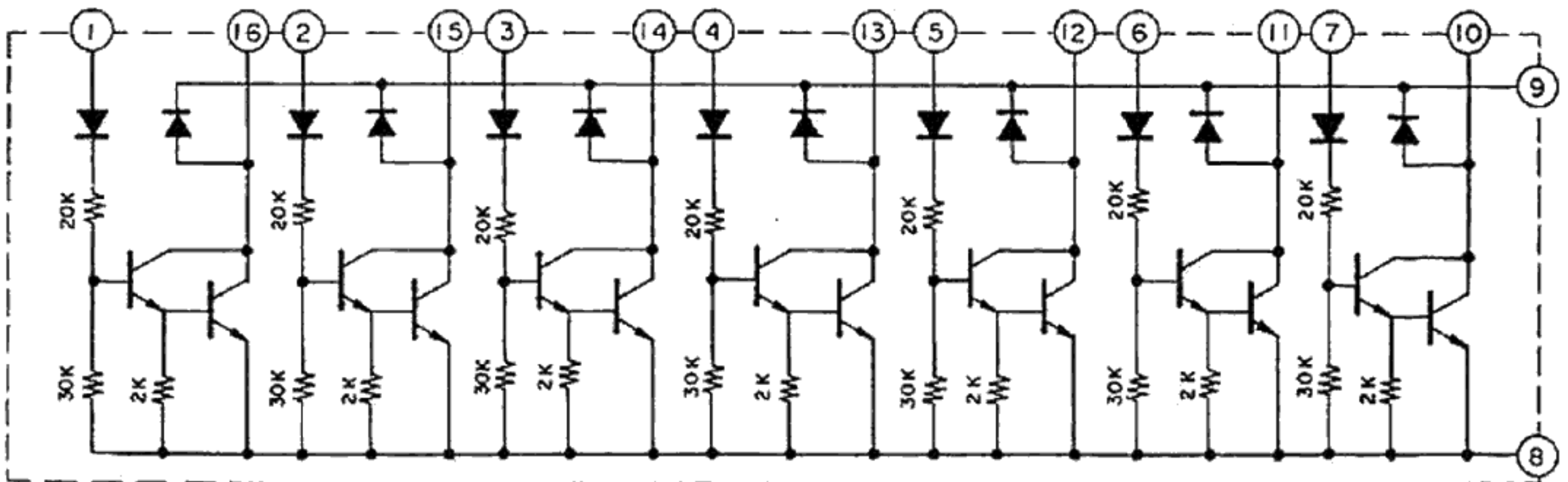

LC7550

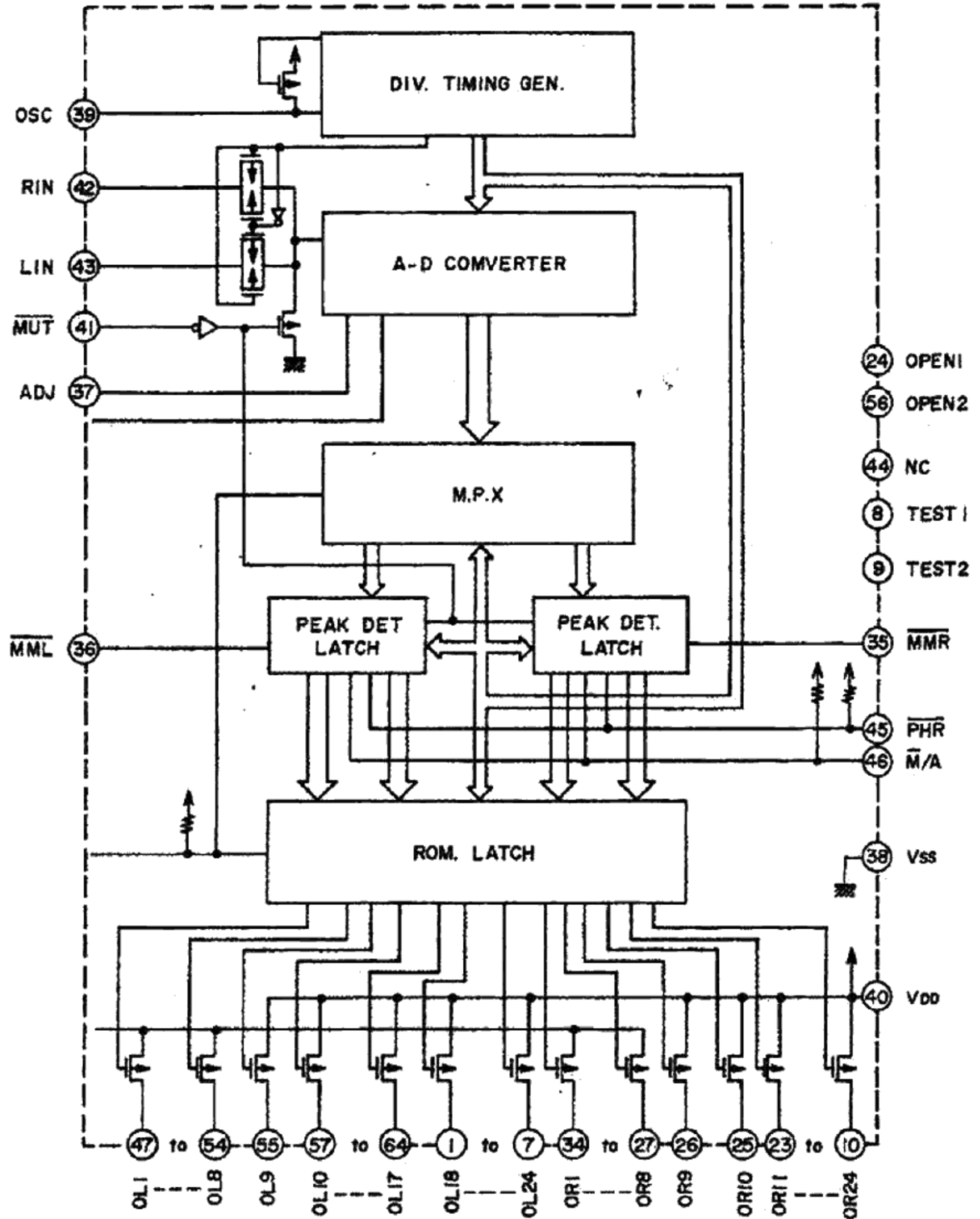

NJM4558D

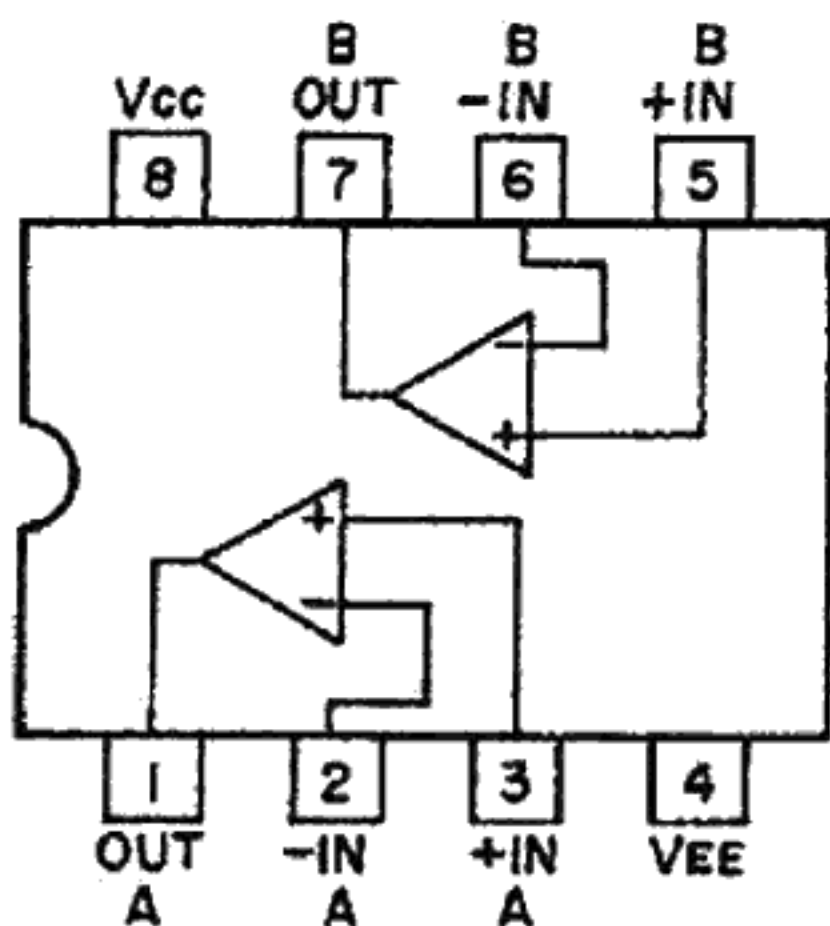

MC14011BCP

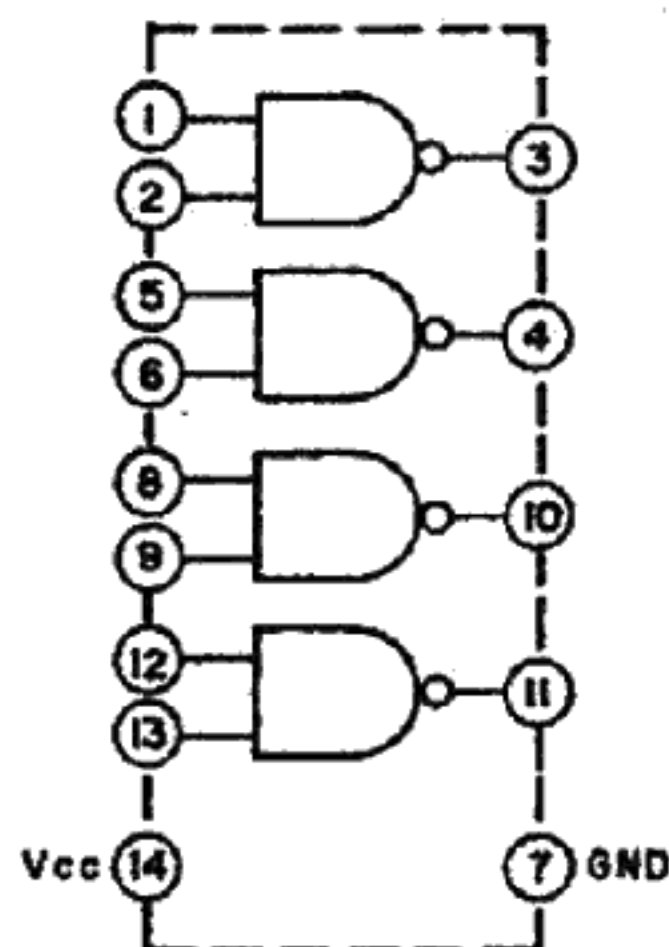

MC14049BPC

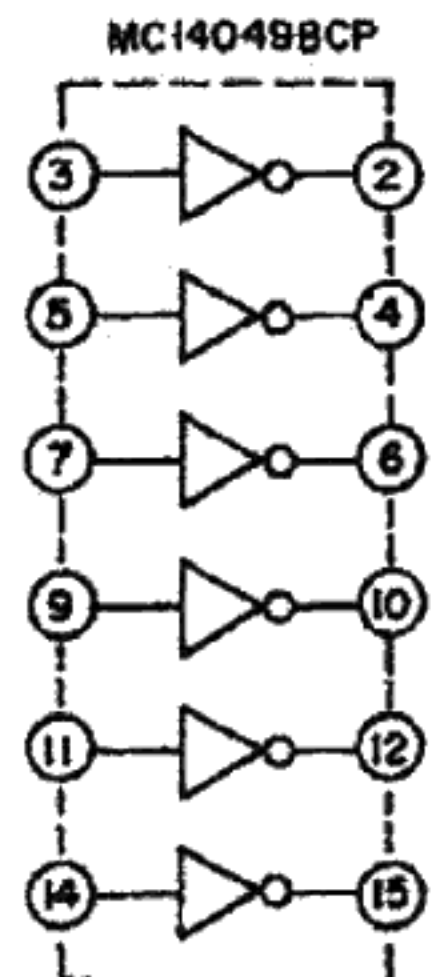

NC= Pin 13,16
VSS= Pin 8
VCC= Pin 1

TA75458S

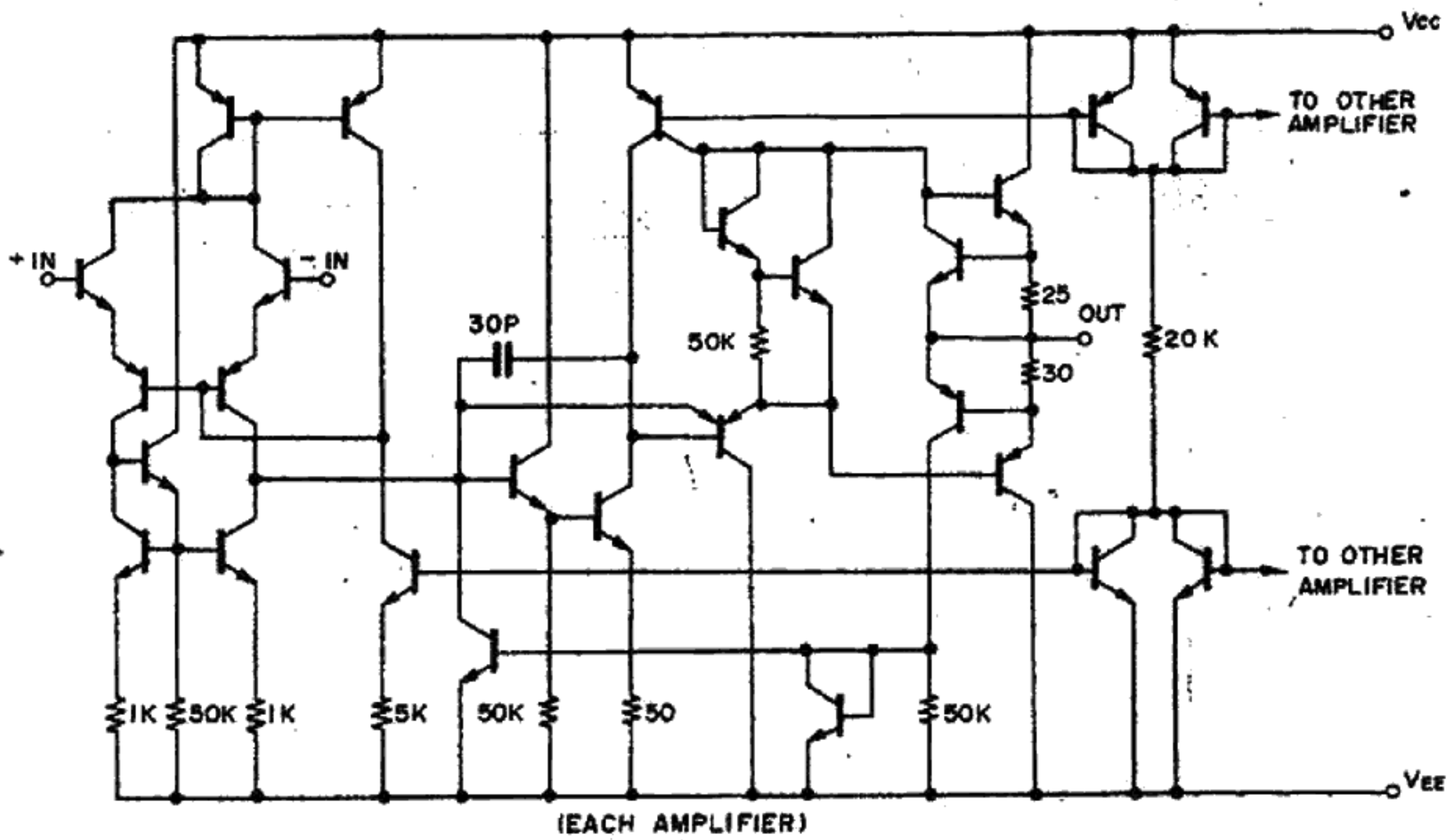

μPD553C-1101152

