

AKAI SERVICE MANUAL

GX-625

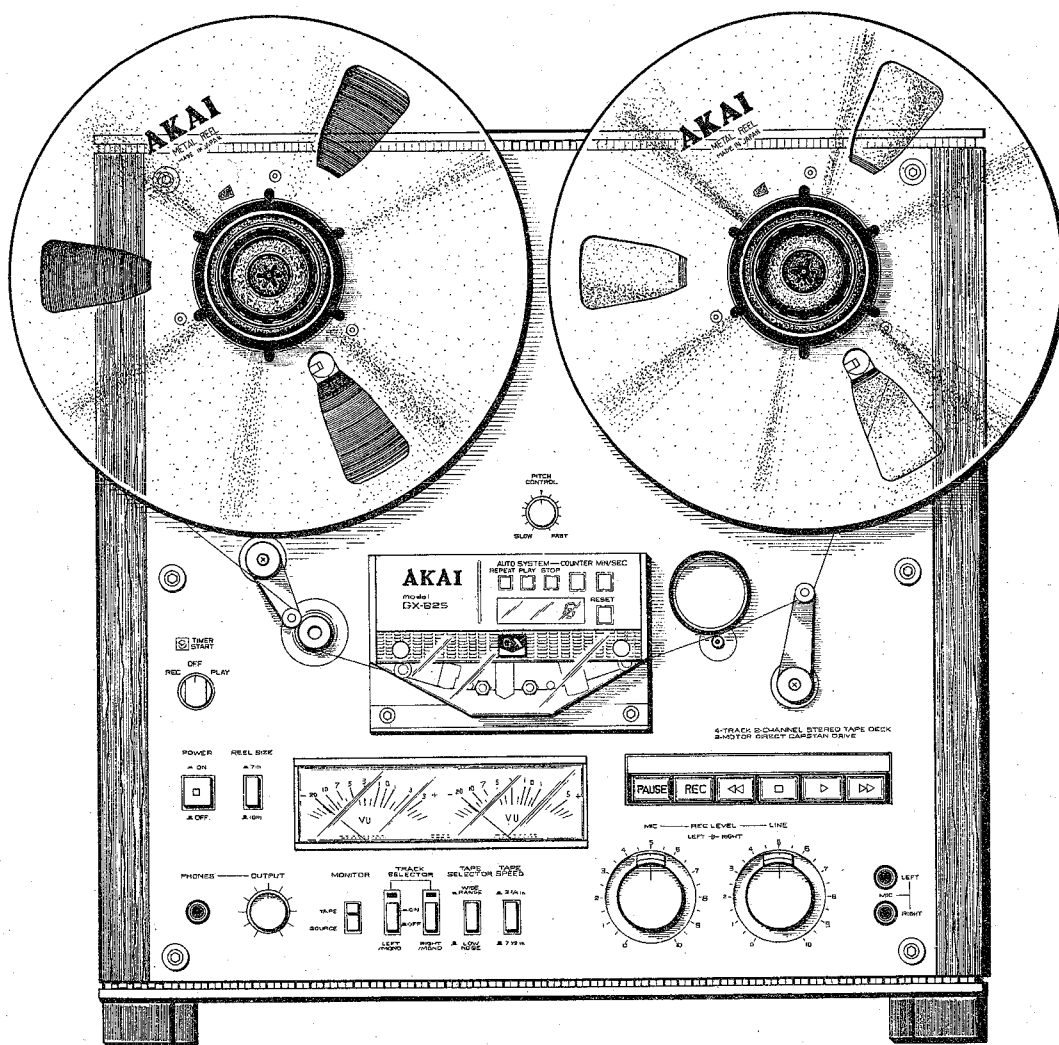

STEREO TAPE DECK

MODEL **GX-625**

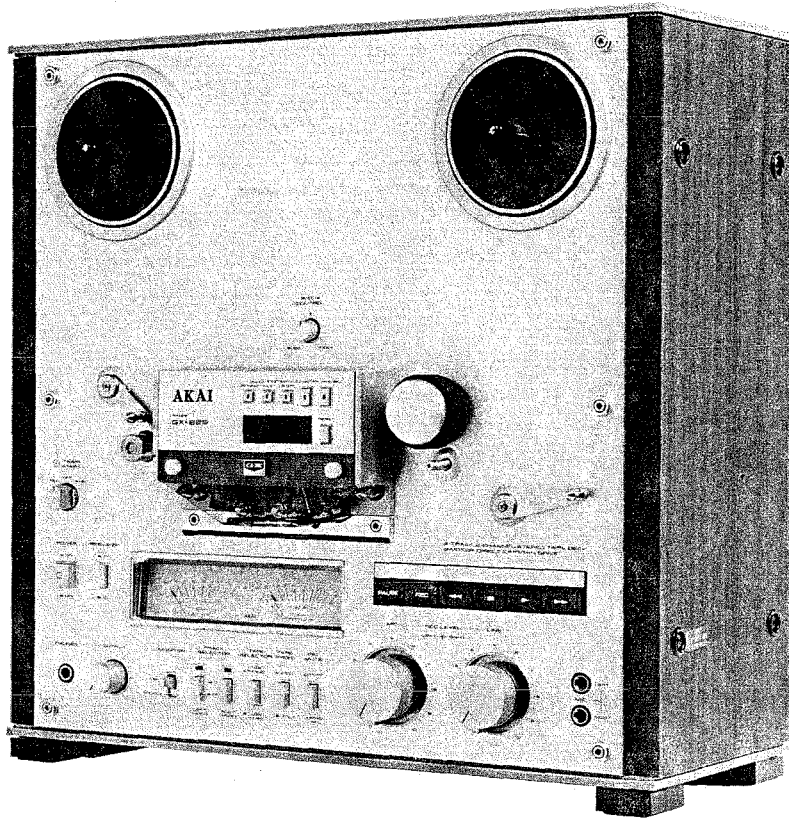

STEREO TAPE DECK

MODEL GX-625

ALSO APPLICABLE TO BLACK PANEL MODEL

SECTION 1	SERVICE MANUAL	3
SECTION 2	PARTS LIST	47
SECTION 3	SCHEMATIC DIAGRAM	70

SECTION 1

SERVICE MANUAL

TABLE OF CONTENTS

I. TECHNICAL DATA	4
II. DISMANTLING OF UNIT	5
III. CONTROLS	6
IV. PRINCIPAL PARTS LOCATION	8
V. VOLTAGE AND CYCLE CONVERSION	10
1. VOLTAGE CONVERSION	10
2. CYCLE CONVERSION	11
VI. CIRCUIT OPERATING PRINCIPALES	12
1. CIRCUIT CONSTRUCTION OF LM8529	12
2. PULSE GENERATING MECHANISM	13
3. TAPE COUNTER OPERATION	13
4. THE SELECTION OF COUNT UP/COUNT DOWN	14
5. SERVO BRAKING DURING AUTO PLAY	14
6. REEL DRIVE CIRCUITRY FOR BRAKE CONTROL	15
7. FIXING THE AMOUNT OF BRAKING (DETERMINING THE NO. OF REEL REVOLUTIONS)	16
8. BRAKE OPERATION	18
9. DIGITAL INDICATOR (SL-1476-04W)	19
10. CIRCUIT CONSTRUCTION OF M54410P	20
11. THE SAMPLE AND HOLD SYSTEM SERVO MOTOR (SCM-200) OPERATION	22
VII. MECHANISM ADJUSTMENT	24
1. TAPE GUIDE HEIGHT ADJUSTMENT	24
2. REEL TABLE HEIGHT ADJUSTMENT	25
3. CAPSTAN SHAFT LOOSE PLAY ADJUSTMENT	25
4. IMPEDANCE ROLLER LOOSE PLAY ADJUSTMENT	25
5. BRAKE BAND POSITION ADJUSTMENT AND BRAKE TENSION ADJUSTMENT	26
6. PINCH ROLLER PLUNGER INSTALLATION POSITION AND PINCH ROLLER ADJUSTMENT	27
7. PAUSE PLUNGER POSITION ADJUSTMENT	27
8. TAPE SPEED ADJUSTMENT	28
9. SERVO BRAKE ADJUSTMENT	29
VIII. HEAD ADJUSTMENT	30
IX. AMPLIFIER ADJUSTMENT	32
X. DC RESISTANCE OF VARIOUS COILS	35
XI. CLASSIFICATION OF VARIOUS P.C BOARDS	36
1. P.C BOARD TITLES AND IDENTIFICATION NUMBERS	36
2. COMPOSITION OF VARIOUS P.C BOARDS	37

For basic adjustments, measuring methods, and operating principles, refer to GENERAL TECHNICAL MANUAL.

I. TECHNICAL DATA

TRACK SYSTEM	4 Track 2 Channel Stereo System
REEL CAPACITY	Up to 10-1/2" reel
HEADS	Erase head × 1 GX recording head × 1 GX playback head × 1
MOTORS	AC servo motor for capstan drive × 1 AC eddy current motors for reel drive × 2
TAPE SPEED	19 cm/s ± 0.8% (7-1/2 ips.) 9.5 cm/s ± 1.0% (3-3/4 ips.) Pitch control: more than ± 6%
WOW & FLUTTER	Less than 0.03% WRMS, 0.08% DIN 45500 at 19 cm/s Less than 0.04% WRMS, 0.10% DIN 45500 at 9.5 cm/s
TAPE WINDING TIME	130 sec. using 740 m (2400 ft.) Tape
FREQUENCY RESPONSE	30 to 26000 Hz ± 3 dB at 19 cm/s 30 to 19000 Hz ± 3 dB at 9.5 cm/s
SIGNAL TO NOISE RATIO	Better than 62 dB at 19 cm/s DIN 45500 Better than 60 dB at 9.5 cm/s DIN 45500
HARMONIC DISTORTION	Less than 0.5%
INPUT	MIC: 0.25 mV (input impedance 2.4 kohms) Required microphone impedance: 600 ohms Line: 70 mV (input impedance 100 kohms)
OUTPUT	Line: 775 mV at 0 VU Required load impedance: more than 20 kohms Phone: 100 mV/8 ohms at 0 VU
DIN	Input: 2 mV (input impedance: 10 kohms) Output: 755 mV Required load impedance: more than 20 kohms
DIMENSIONS	440 (W) × 446 (H) × 241 (D) mm (17.3 × 17.6 × 9.5")
WEIGHT	17.6 kg (38.9 lbs)
POWER REQUIREMENTS	100V 50/60 Hz for Japan 120V 60 Hz for US & Canada 220V/240V switchable, 50 Hz for European countries & Australia 110/120/220/240V 50/60 Hz, switchable for other countries
POWER CONSUMPTION	JPN 80 W CSA, AAL 150 W U/T 150 W

* For improvement purpose, specifications and design are subject to change without notice.

II. DISMANTLING OF UNIT

In case of trouble, etc. necessitating dismantling, please dismantle in the order shown in the photographs. Reassemble in reverse order.

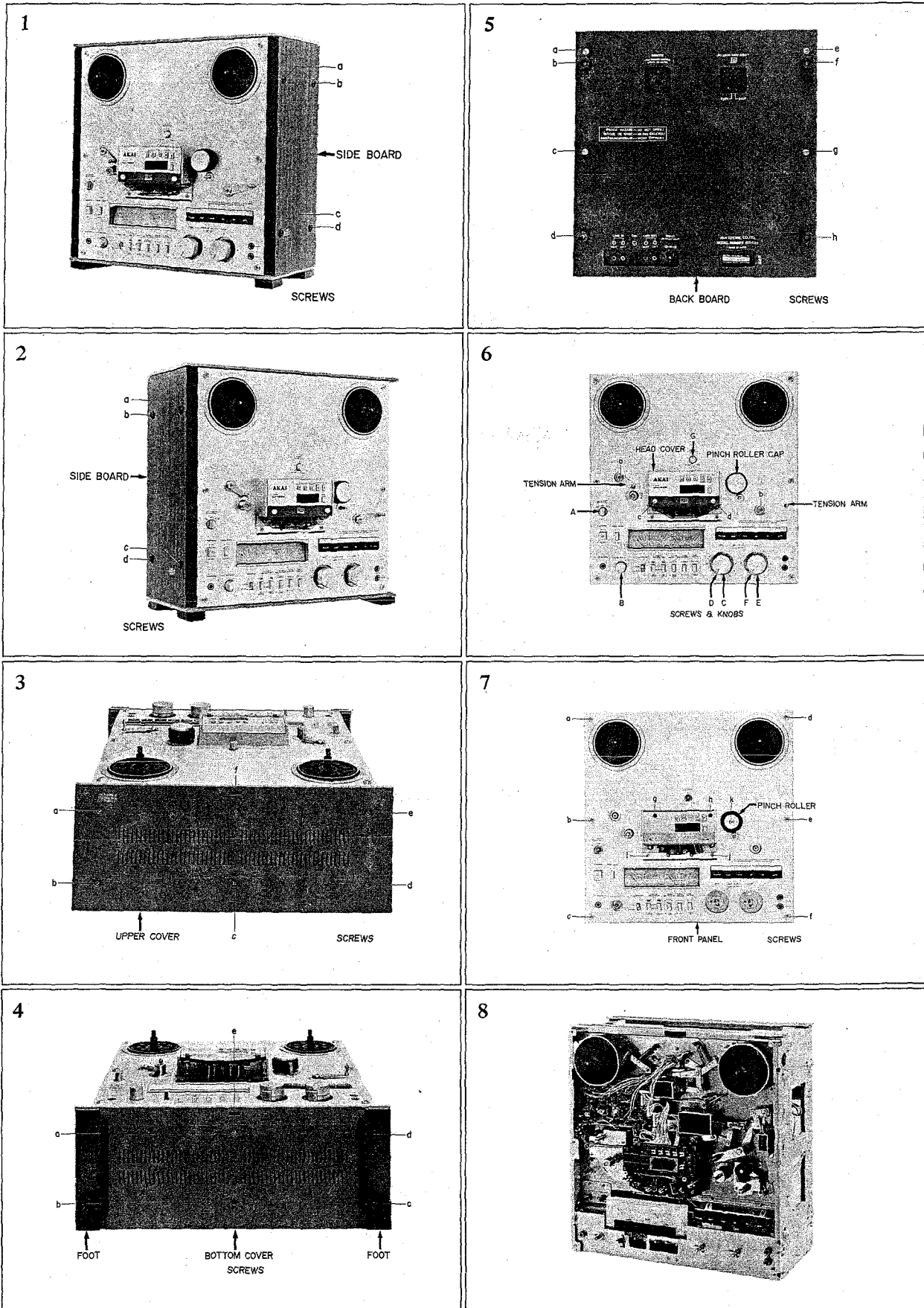

III. CONTROLS

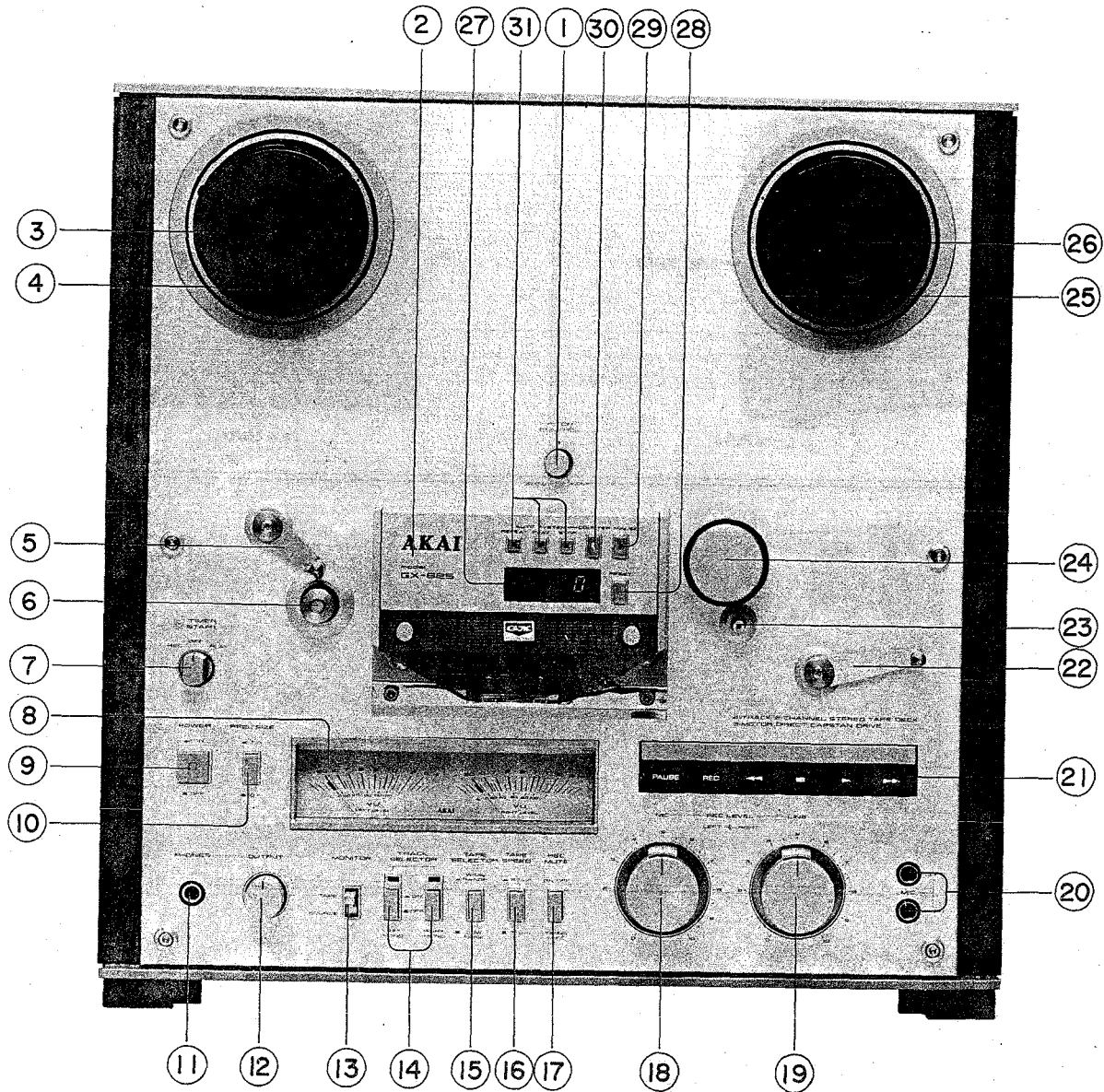

- | | |
|-----------------------------|---|
| 1. PITCH CONTROL | 17. RECORDING MUTE |
| 2. HEAD COVER | 18. MICROPHONE INPUT CONTROLS (REC LEVEL – MIC) |
| 3. BUILT-IN REEL RETAINER | 19. LINE INPUT CONTROLS (REC LEVEL – LINE) |
| 4. SUPPLY REEL TABLE | 20. MICROPHONE JACKS |
| 5. TAPE TENSION LEVER | 21. OPERATING BUTTONS |
| 6. IMPEDANCE ROLLER | 22. AUTOMATIC STOP/TAPE TENSION LEVER |
| 7. TIMER START SWITCH | 23. CAPSTAN |
| 8. VU METERS | 24. PINCH ROLLER |
| 9. POWER SWITCH | 25. TAKE-UP REEL TABLE |
| 10. REEL SIZE SELECTOR | 26. BUILT-IN REEL RETAINER |
| 11. HEADPHONE JACK | 27. LED DISPLAY |
| 12. OUTPUT LEVEL CONTROL | 28. RESET BUTTON |
| 13. TAPE MONITOR SWITCH | 29. MIN/SEC BUTTON |
| 14. TRACK SELECTOR SWITCHES | 30. COUNTER BUTTON |
| 15. TAPE SELECTOR SWITCH | 31. AUTO SYSTEM |
| 16. TAPE SPEED SELECTOR | |

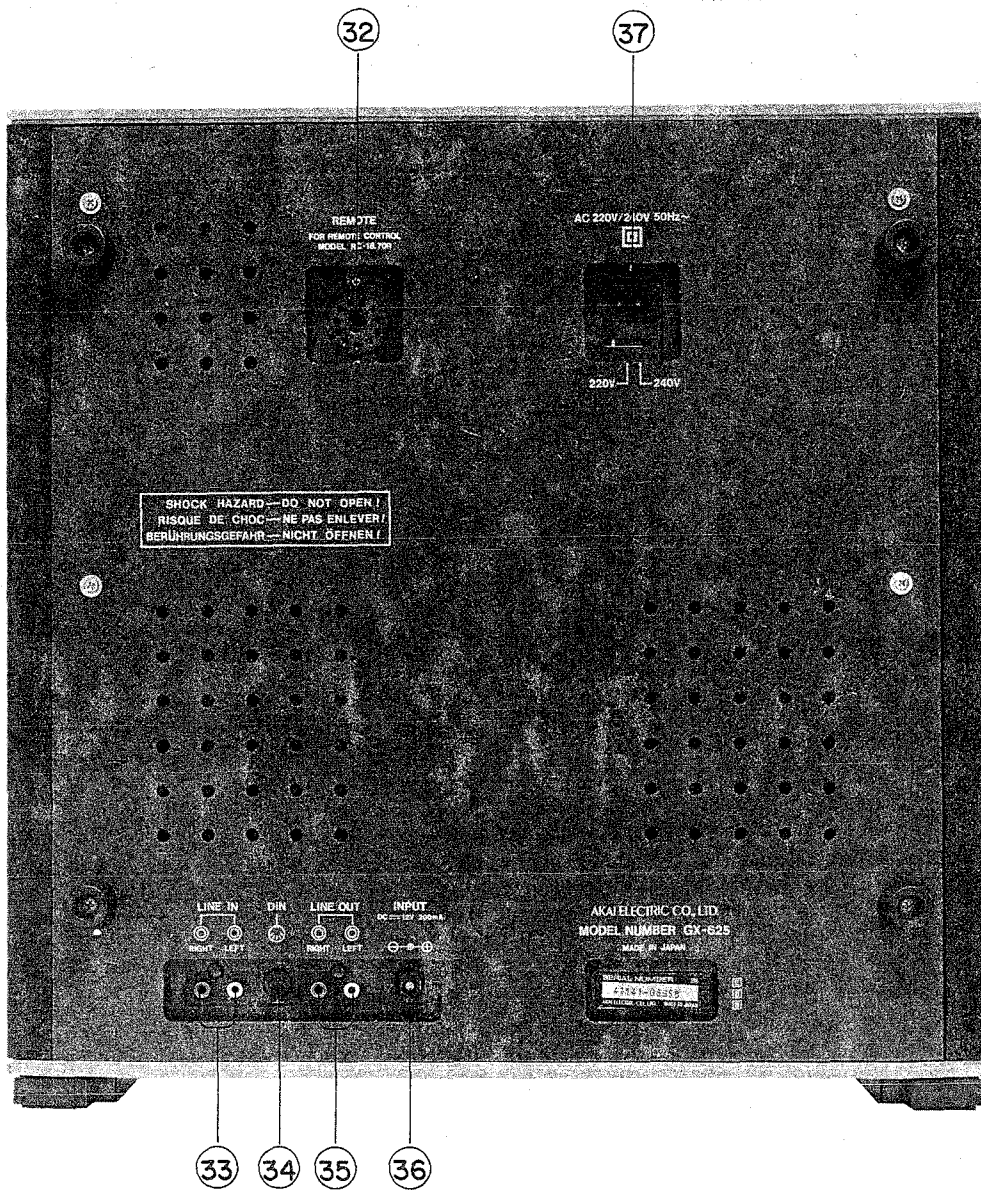

Fig. 1 Controls

- 32. REMOTE CONTROL JACK
- 33. LINE INPUT JACKS
- 34. DIN JACK
- 35. LINE OUTPUT JACKS
- 36. AC ADAPTER JACK
- 37. AC INLET

IV. PRINCIPAL PARTS LOCATION

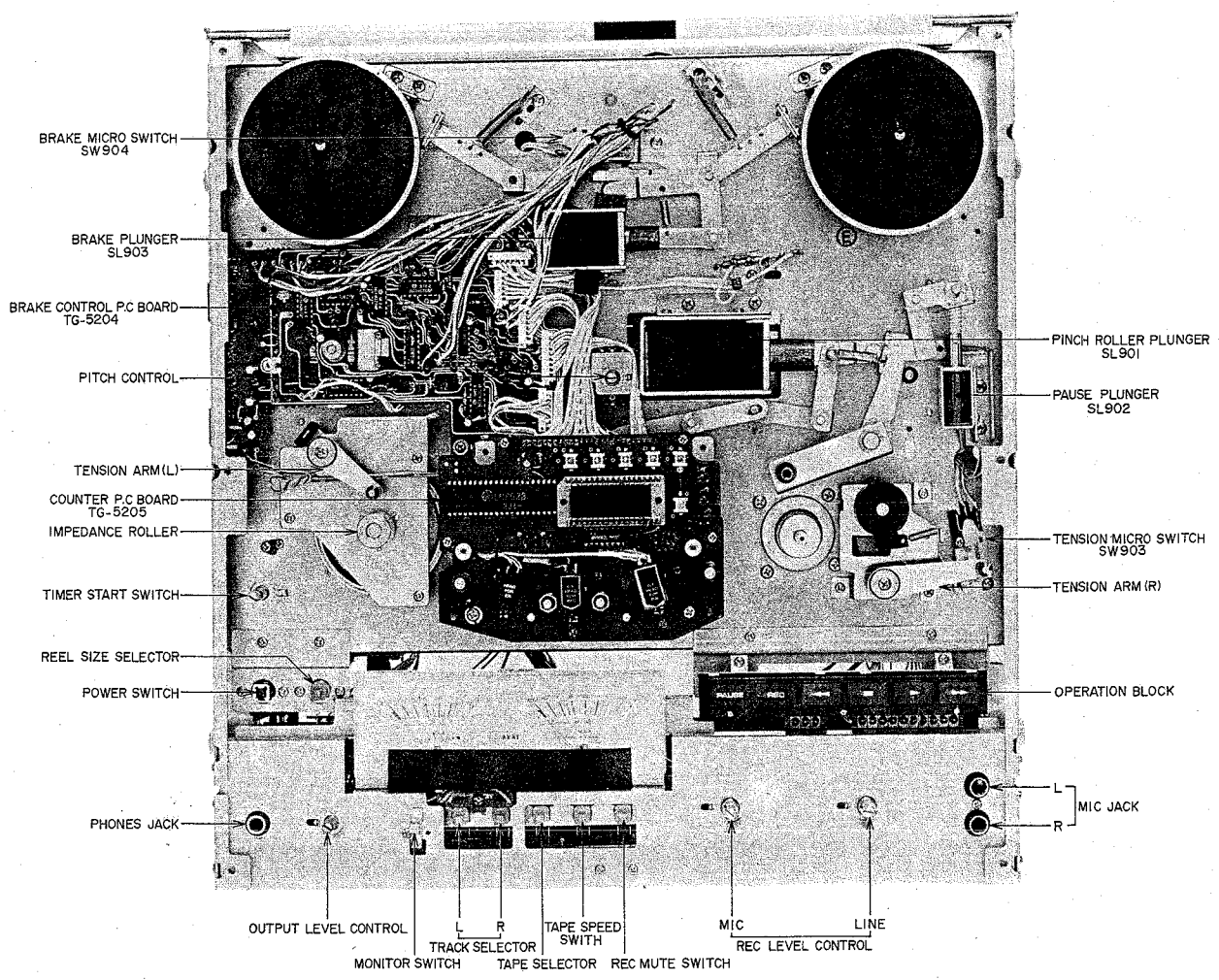

Fig. 2 Front View

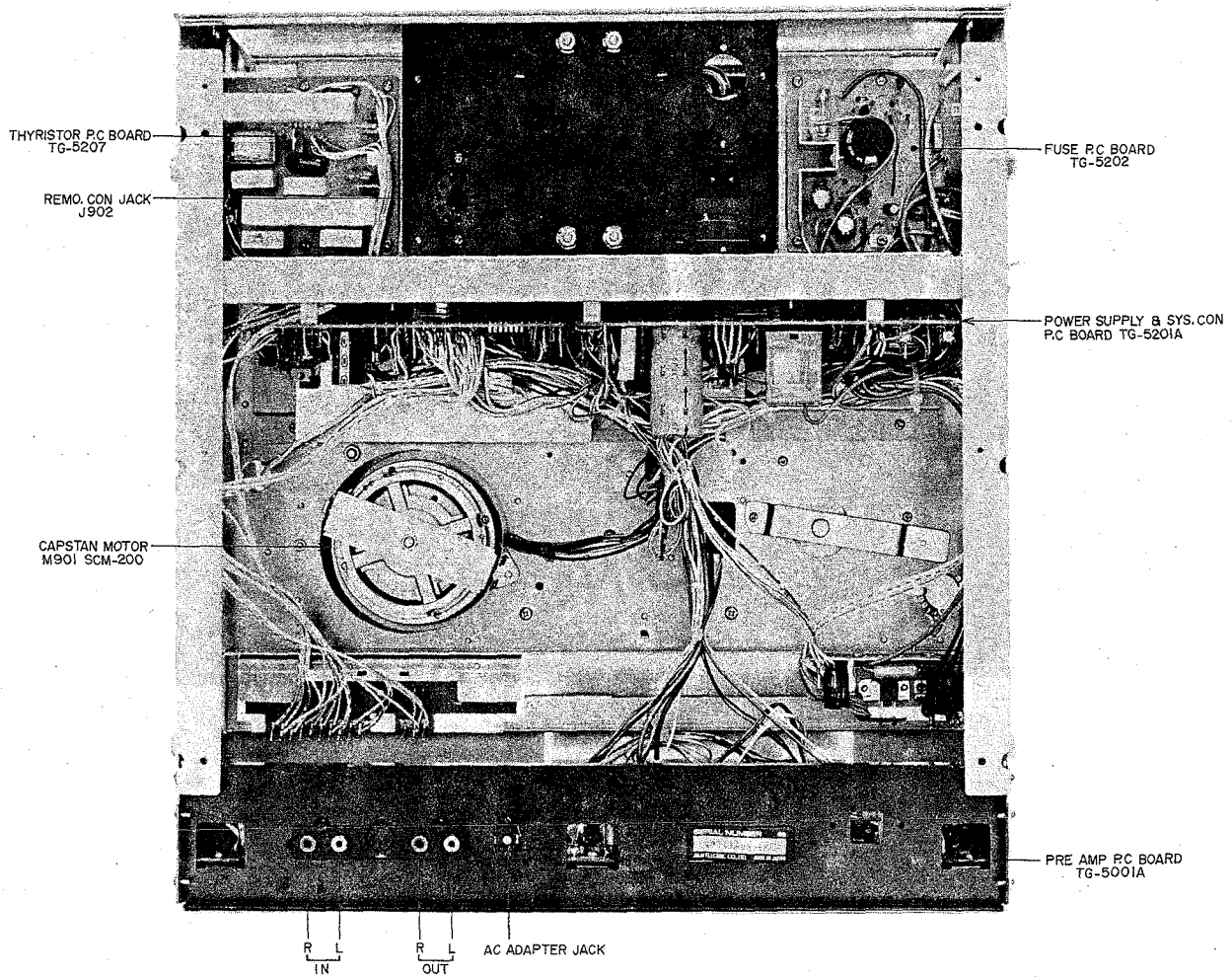
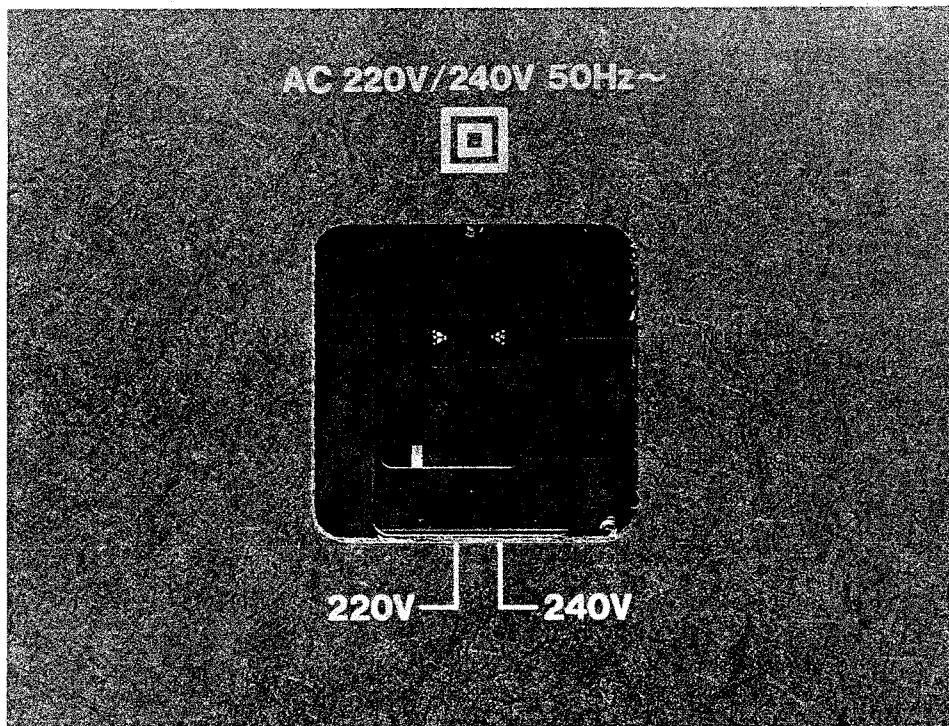
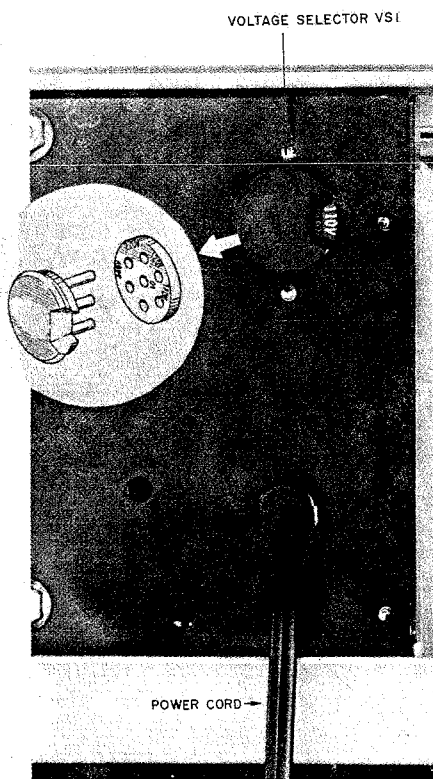

Fig. 3 Rear View

V. VOLTAGE AND CYCLE CONVERSION



(a) CEE, UK, SAA Model



(b) U/T Model

1. VOLTAGE CONVERSION (Refer to Fig. 4)

1) JPN Model (100V, 50/60 Hz)
CSA, AAL Model (120V, 60Hz)
Voltage can not be switched.

2) CEE, UK Model (220V/240V, 50Hz)

A voltage selector switch is provided under the AC inlet on the back side of machine. Select the proper voltage with this switch according to the voltage to be used. Move the switch to the left side for 220V and to the right side for 240V.

3) U/T Model (110V/120V/220V/240V, 50/60 Hz)

Remove the back board and look for the voltage selector on the upper right portion of the machine. Change the position of voltage selector plugs so that the voltage to be used coincides with the voltage shown through the opening of voltage selector plug. Fuse change is not necessary.

Fig. 4 Voltage Conversion

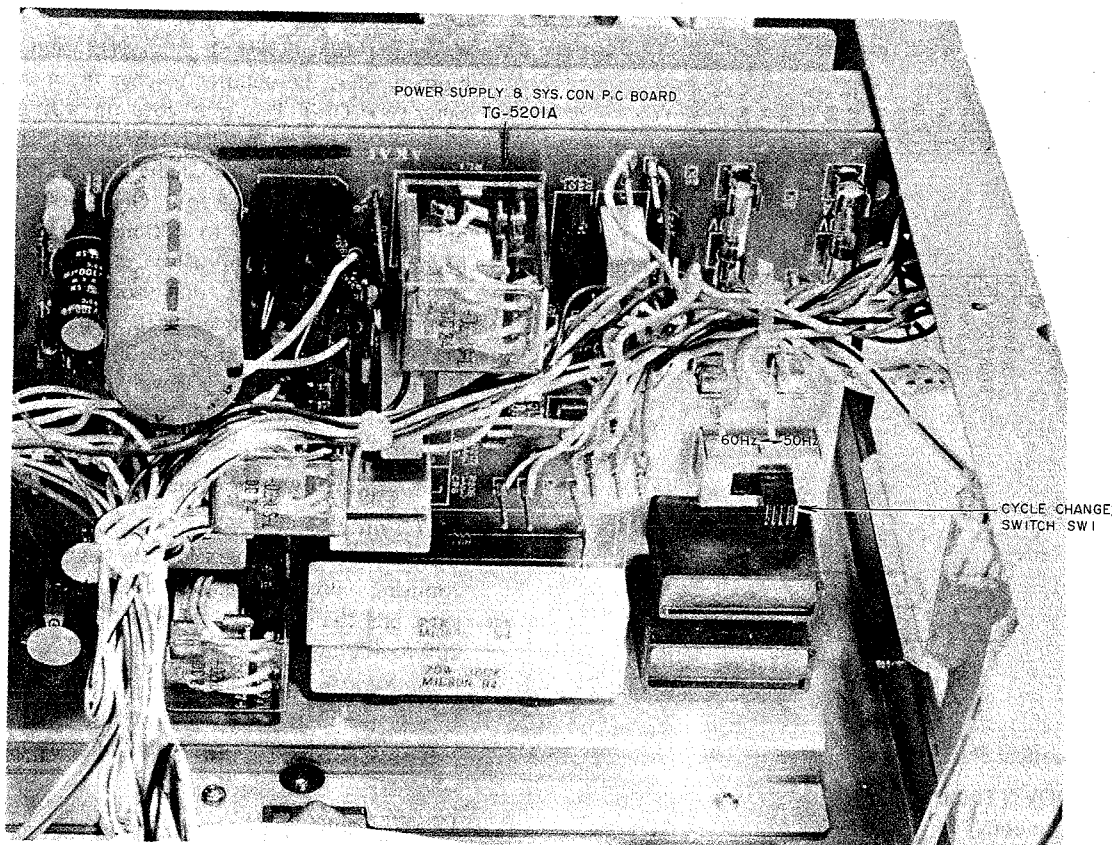

Fig. 5 Cycle Conversion (U/T, JPN Model)

2. CYCLE CONVERSION (Refer to Fig. 5)

Cycle can be converted only in U/T, JPN Model. Remove the back board and select the position of switch located in the recess at right portion of Power Supply & Sys. Con P.C Board to correspond to the frequency of power to be used. Move the switch to the right for 50 Hz and to the left for the 60 Hz.

CAUTION: When selecting the voltage or cycle, turn off the power and disconnect the power cord.

VI. CIRCUIT OPERATING PRINCIPALES

1. CIRCUIT CONSTRUCTION OF LM8529

1) Diagram showing pin position

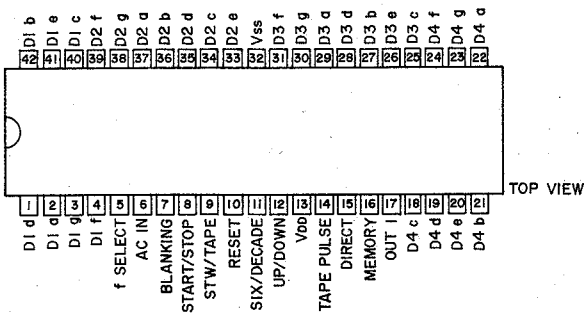

Fig. 6

2) Display Board

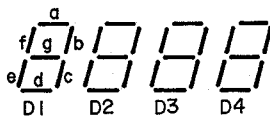

Fig. 7

3) Theoretical Functioning

a. UP/DOWN (input)

“H” for counting up.

“L” (or open) for countdown.

b. TAPE PULSE (input)

Displays 0 to 9999 or 0 to 5959 according to the counting pulse.

When 1 or 5 pulses are added to the TAPE PULSE input the display will show changes of ± 1 only. There is a built in $5 \mu\text{sec}$ chattering prevention circuit in this terminal.

c. DIRECT (input)

When 5 pulses are input into the TAPE PULSE terminal and this terminal is set to “L” or open, the display will change by $+1$ or -1 .

When 1 pulse is input into the TAPE PULSE terminal and this terminal is set to “H”, the display will change by $+1$ or -1 .

d. SIX/DECADE

The counter becomes decade when this terminal is “L” (or open) and the display can show from 0 to 9999 according to the counting pulse.

The counter becomes a sixtieth counter when this terminal is “H” and the display can show from 0 to 5959 according to the counting pulse.

e. ALL ZERO COUNTER DETECTION (OUT 1 output)

At the moment when the counter changes from 1 to 0, the output driver OUT 1 goes ON within about 200 to 400 msecs, ie: OUT 1 becomes “H”.

f. MEMORY STOP DETECTION (OUT 1 output)

At the moment when the MEMORY INPUT terminal changes from “L” to “H”, the contents

of the tape counter (N) are memorized. After the tape counter has counted up $N+1, N+2 \dots N+k$, it counts down $N+k-1 \dots N+1$ and at the moment that the counter reaches the memorized value (N), OUT 1 output goes on within about 200 to 400 msecs, ie: OUT 1 becomes “H”. Also when countdown begins, at the moment when the counter changes from 1 to 0, OUT 1 output goes on within about 200 to 400 msecs, ie: OUT 1 becomes “H”. Further when counting up 0, 1, 2, $\dots N-2, N-1$, at the moment when the counter reaches the memorized value (N) OUT 1 output goes on within about 200 to 400 msecs, ie: OUT 1 becomes “H”. However if the memory terminal is “L”, OUT 1 goes off, ie: OUT 1 remains “L”.

g. Item f applies when the memory terminal is “H”.

h. OUT 1 output

Output terminal generating the signal detecting counting pulse zero, all zero counter and memory stop, and the generated pulse is “H” within about 200 to 400 msecs.

i. STW/TAPE input

If this terminal is “H”, counter will display the stop watch and if at “L” will display the tape counter.

j. RESET input

With i’s STW/TAPE terminal at “H” the stop watch counter will be reset to zero when this terminal is also put to “H”. With i’s STW/TAPE terminal at “L” (open) the tape counter will be reset to zero when this terminal is put to “H”. This reset terminal becomes open and “L”.

k. Initial clear circuitry: Counter resetting with power on.

This is a reset circuit to initialize the tape counter and stop watch counter inner LSI at the moment when voltage is added to the LSI. At the initial condition the counter will always be 0.

l. BLANKING input

All the segments’ output can be made “L” by making this BLANKING terminal “L”.

m. START/STOP input

When the START/STOP terminal is put to “H”, the display will go up 1 per second.

When at “L”, the display will stop at +1.

There is an inbuilt 15 to 30 msecs chattering prevention circuit in this terminal.

n. AC IN input

The commercial frequency (50, 60 Hz) is added to this terminal as the standard frequency for the stop watch. There is a built-in hysteresis circuit in this terminal.

o. f SELECT input

When 50 Hz is added to n’s input terminal, the frequency selection terminal is set to “H” and when 60 Hz is added, is set to “L”

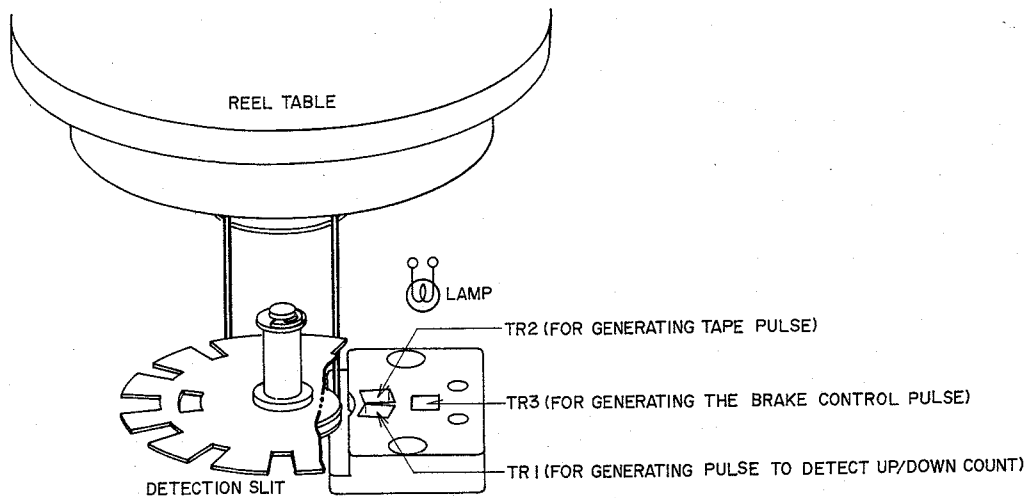

Fig. 8

2. PULSE GENERATING MECHANISM

In the GX-625, the pulse for the tape counter and the pulse for braking control during auto system are both generated by reel revolution. As in Fig. 8 a photo transistor is positioned under the detection slit and is lit by a lamp above. When this detection slit is turned by the reel table the photo transistor goes ON and OFF and the pulses are generated.

3. TAPE COUNTER OPERATION

As the reel turns, TR1 and TR2 go on and off repeatedly and pulses are generated. The pulse generated by TR1 is added to the UP/DOWN input terminal of COUNTER LSI LM8529. This is the pulse which decides whether there is to be count up or count down. The pulse generated by TR2 is added to the COUNTER LSI's Tape Pulse input but if added

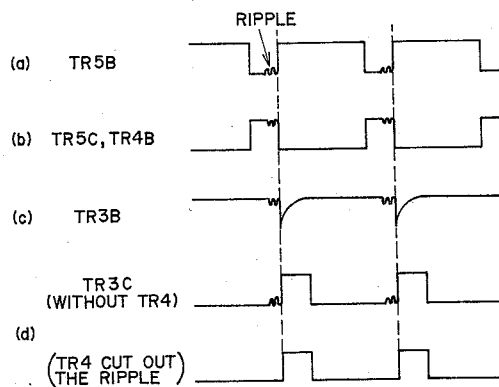
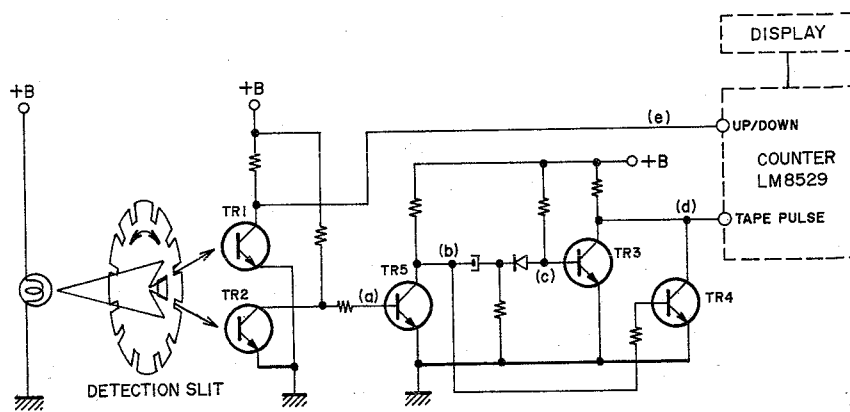

Fig. 9

as it stands, it will be unable to detect correctly whether it is counting up or down when the tape counter is counting single pulses from the first initial position (When the detection slit is stopped). To prevent this, the pulse width and phase are changed by TR5 and TR3. The characteristics of these waveform changing circuits are decided by the installation position of the photo transistors TR1 and TR2.

If we explain the circuitry's operation, the pulse generated by the photo transistor TR2 is reversed by TR5 and differentiated by CR. Only the negative pulses of the diode differentiated pulses are added to TR3's base.

In TR3's collector, the pulse generated by TR2 and the raised section are the same but a pulse with a narrowed positive pulse width is generated.

TR4 cuts the fear of ripple being generated by the raised section of TR2's pulse and prevents miscounting.

4. THE SELECTION OF COUNT UP/COUNT DOWN

As in Fig. 10, pulse is added to the UP/DOWN terminal and TAPE PULSE terminals of COUNTER LSI. This counter counts up when the UP/DOWN is "H" and the TAPE PULSE terminal is raised to "H". It counts down when the UP/DOWN terminal is "L" and the TAPE PULSE terminal is raised to "H". Therefore, regardless of the UP/DOWN terminal's

position, it will decide to count up or count down if the TAPE PULSE terminal is raised to "H".

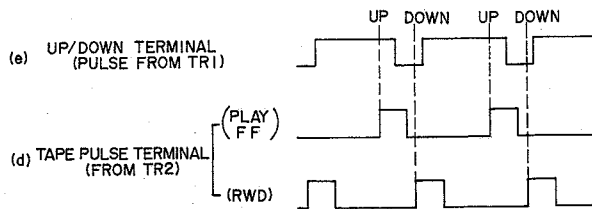

Fig. 10

5. SERVO BRAKING DURING AUTO PLAY

It is essential to stop tape run completely when the tape counter reaches "0" from RWD mode in either auto stop, auto play or auto repeat. As open reel tapes have higher inertia the tape must be slowed down from high speed revolution before stopping at a designated point. In the GX-625 there are two braking points with 10" reels at "29" and "9" and one with 7" reels at "9" on the tape counter.

DETECTING THE BRAKING POINTS (29, 9, 0)

As anode common LEDs are used, the lighted LEDs' cathode side is L and the unlighted cathode side is H.

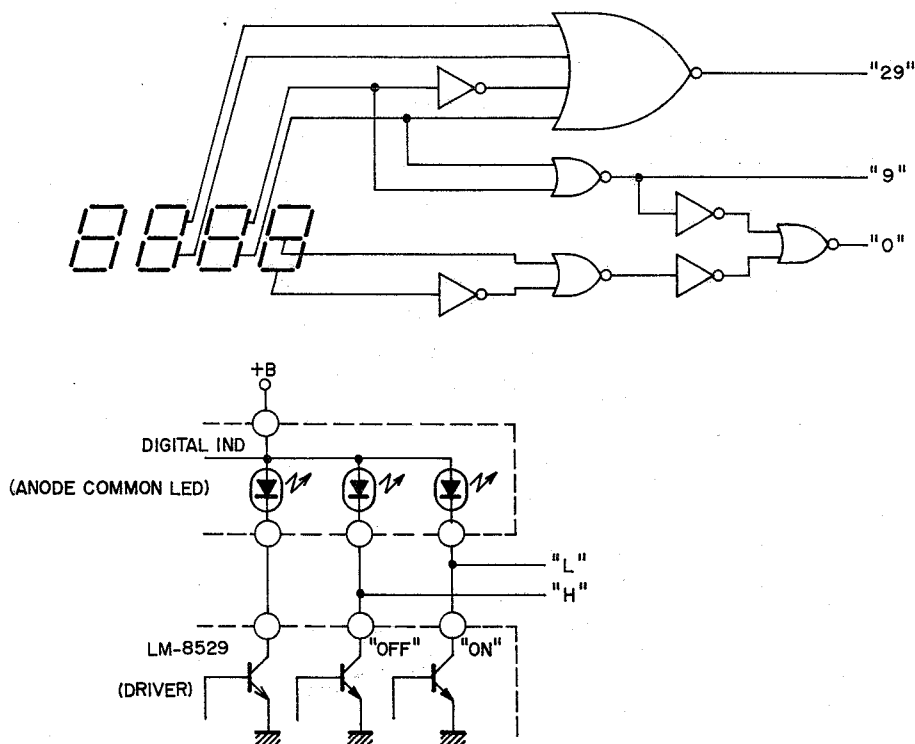

Fig. 11

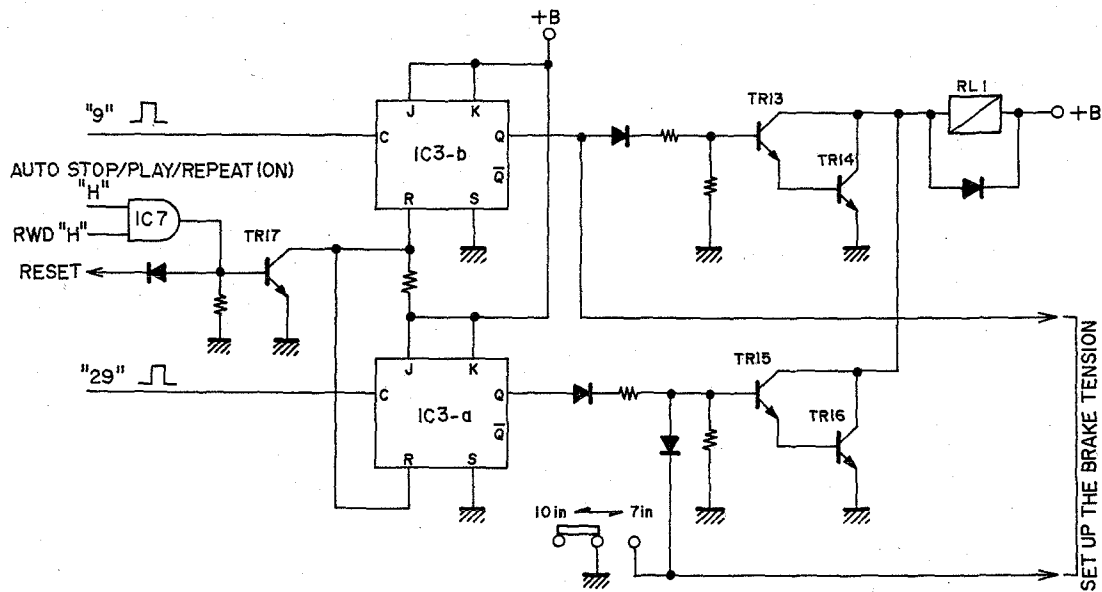

Fig. 12

6. REEL DRIVE CIRCUITRY FOR BRAKE CONTROL

1) JK Flip Flop

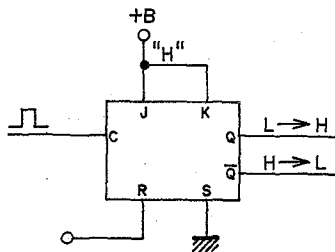

Fig. 13

As shown in the diagram, when terminals J and K are kept at "H" they work in the same way as T flip flop, and as input pulse enters terminal C, the output of Q and \bar{Q} are reversed in turn. When the RESET terminal is "H" Q = "L" and \bar{Q} = "H" with absolutely no relationship to J, K or C terminals.

2) Reel Drive

The number 6 terminal of IC7 will be "H" if either the auto stop, auto play or repeat switches are on. Terminal number 5 becomes "H" in the RWD mode. Therefore the output at terminal 4 will be "H" and TR17 is ON so the reset terminal of IC3-b becomes "L". In RWD mode or when the Auto system switch is not depressed, IC3-a/b has been reset to Q terminal is "L".

At this point when the pulse is input from the tape counter which is at "29", terminal Q reverses and becomes "H". As a result, TR15 and TR16 go ON and relay RL1 is activated. However this explanation applies to 10" reels only. With 7" reels, the Q output passes the reel size selector and as it is dropped to earth the relay is not activated.

When the pulse from the tape counter at "9" is input, IC3-b's Q output is reversed, becoming "H" and relay RL1 is activated by TR13 and TR14.

7. FIXING THE AMOUNT OF BRAKING (DETERMINING THE NO. OF REEL REVOLUTIONS)

Pulse is generated in TR3's collector by the revolution of the detection slit. TR21 is turned ON and OFF repeatedly by this pulse. The pulse from TR21's collector and emitter is rectified and added to TR22's gate.

The voltage added to this gate changes according to the number of pulses from TR3 or in other words, the number of reel revolutions.

Consequently the voltage flowing between TR22's drain and source also changes, so when the number of revolutions does not reach the fixed figure TR23 does not go ON. It is VR1 5 k Ω which determines the number of reel revolutions turning TR23 ON. Thus it is this volume which determines by operating the brake how low the number of reel revolutions should drop. This volume also fixes the number of reel revolutions after the brake is activated at "29" on the tape counter. The number of revolutions from "9" on the tape counter is lower than after "29" and this is fixed by putting TR25 and TR26 ON and adding bias to TR22's gate. With a 7" reel, the number of revolutions from "9" on the tape counter is fixed at a lower figure than "29" but higher than "9" on the tape counter with 10" reels by TR24 adding bias to TR22's gate.

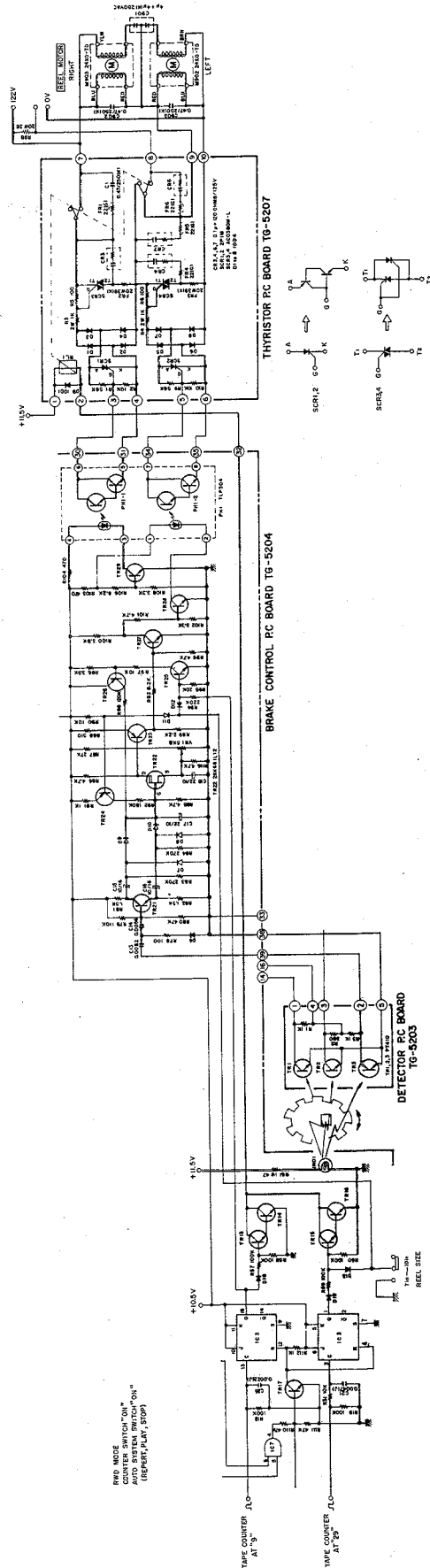

Fig. 14 When the no. of reel revolutions is high

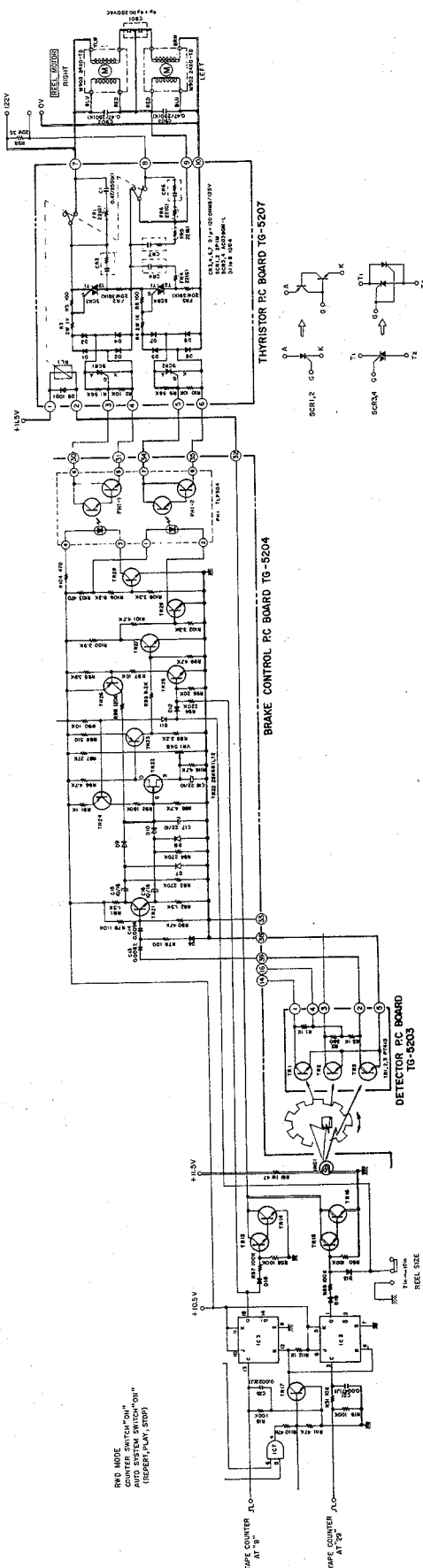

Fig. 15 When the no. of reel revolutions is low

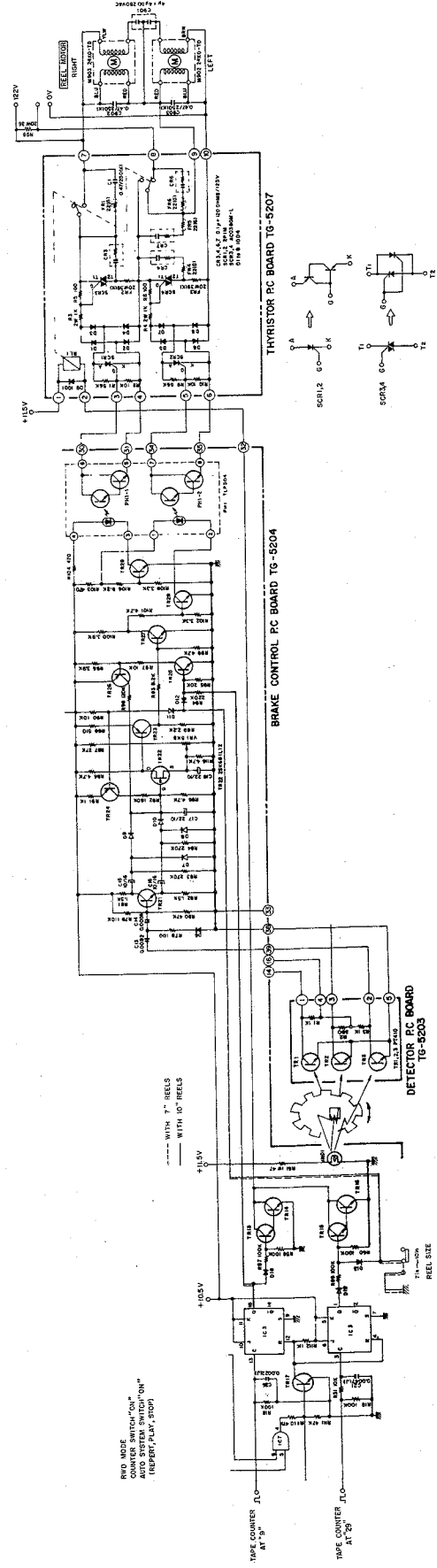
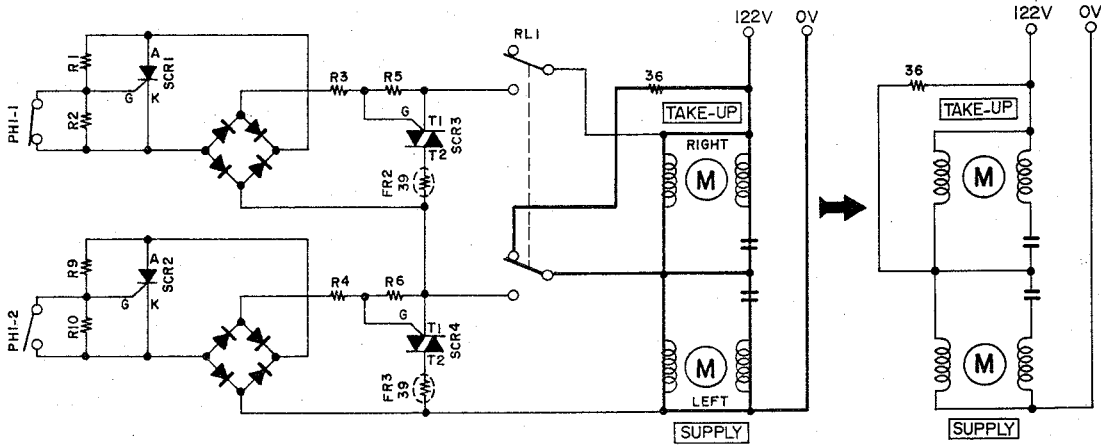
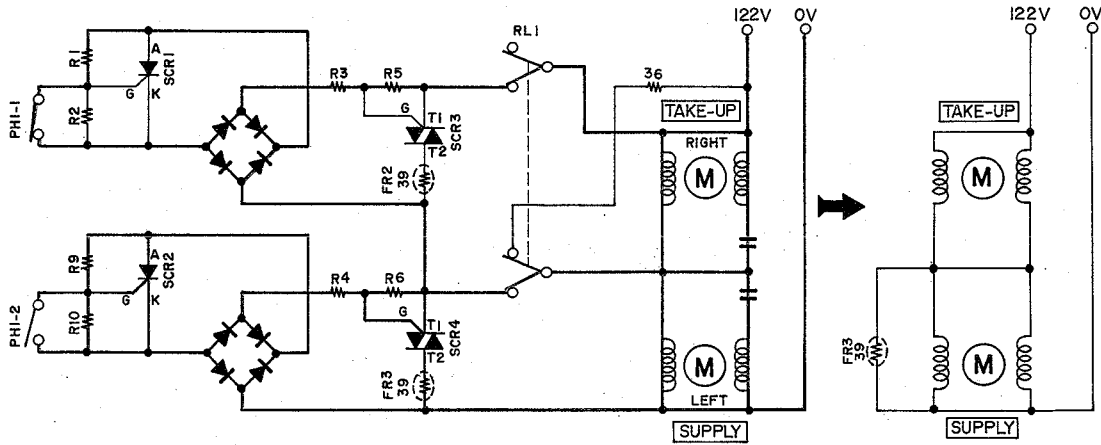

Fig. 16 Fixed no. of revolutions from tape counter at "9"

8. BRAKE OPERATION



(a) RWD mode



(b) Braking from RWD mode (When fixed number of revolutions is exceeded.)

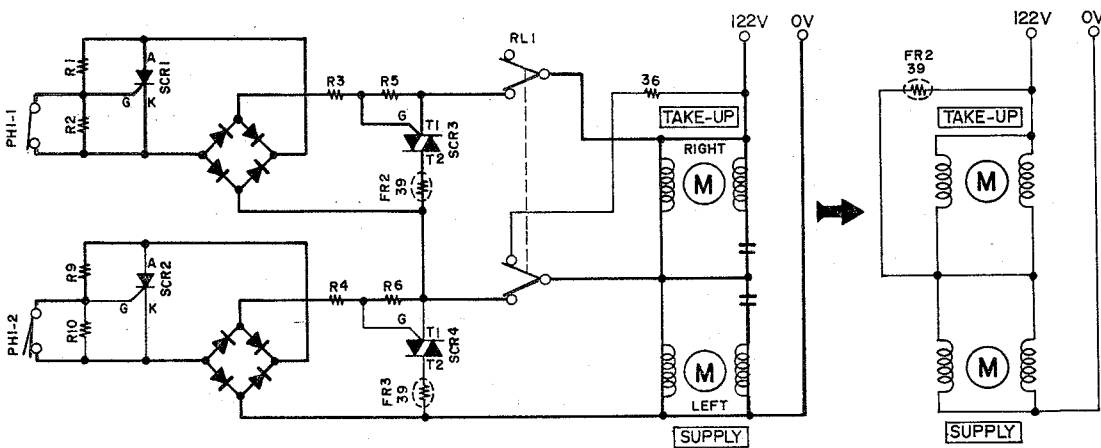

(c) After the reel has begun revolving (Just after the RWD button is depressed.)
Or when the number of revolutions is lower than the fixed number due to braking.

Fig. 17

When the deck is put into RWD, the voltage added to both motor terminals is low and the force of revolution weakens because the resistor of 36 ohms parallel to the take up reel motor is connected. On the other hand the voltage to the supply reel motor is high and the force of reel revolution is strong. Therefore the tape is wound onto the supply reel. (Fig. 17-(a)). As the reel is revolving faster, PH1-1 goes ON and PH1-2 goes OFF. At this point the pulse from the tape counter, when it is at "29" or "9", enters and relay RL1 is activated. The current passes through RL1 and flows as shown by the red line in Fig. 17-(b). SCR1 goes OFF as the electric potential difference between the gate and the cathode disappears as PH1-1 goes ON, and it stays OFF because no voltage to switch on is added to SCR3's gate.

SCR2 goes ON because electric potential difference is created between its gate and cathode by a flow of current to R10. By putting SCR2 ON, large current flows to R4, bias is added to SCR4's gate with the result that SCR4 goes ON. From the above operation, the circuitry on the left ahdn side of Fig. 17-(b) can be written as the right hand side. This is seen in the fact that high voltage has been added to the take up reel motor and the voltage to both terminals of the supply reel motor has been lowered by FR3 39 ohms. In other words, a state the same as FF has been momentarily created during RWD and by adding force in the opposite direction to the direction of reel revolution the number of reel revolutions can be decreased.

Due to the same operation, when the number of reel revolutions is lower than designated, it goes into RWD because PH1-1 and PH1-2's ON and OFF are reversed. In this way, repeating the RWD and braking operations according to the number of reel revolutions, the number can be maintained to stop at any time and the brake will go on and tape run be stopped by the pulse from the tape counter when it is at "0".

9. DIGITAL INDICATOR (SL-1476-04W)

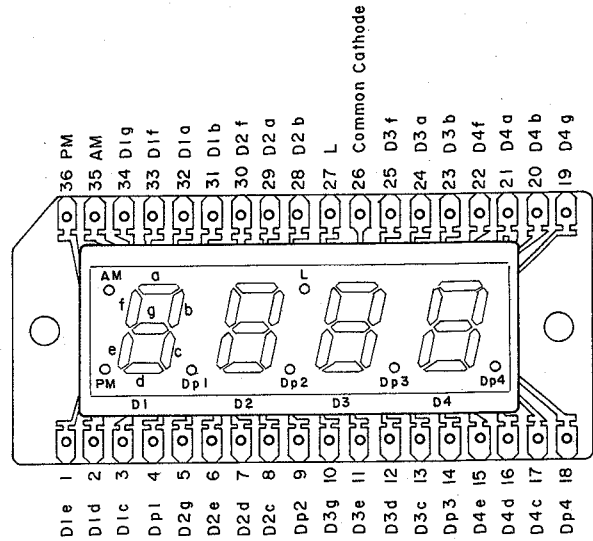

10. CIRCUIT CONSTRUCTION OF M54410P

This logic IC has been developed for an operation key that will maintain a HIGH output level by even a momentary low level in the desired input terminal.

1) Block Diagram

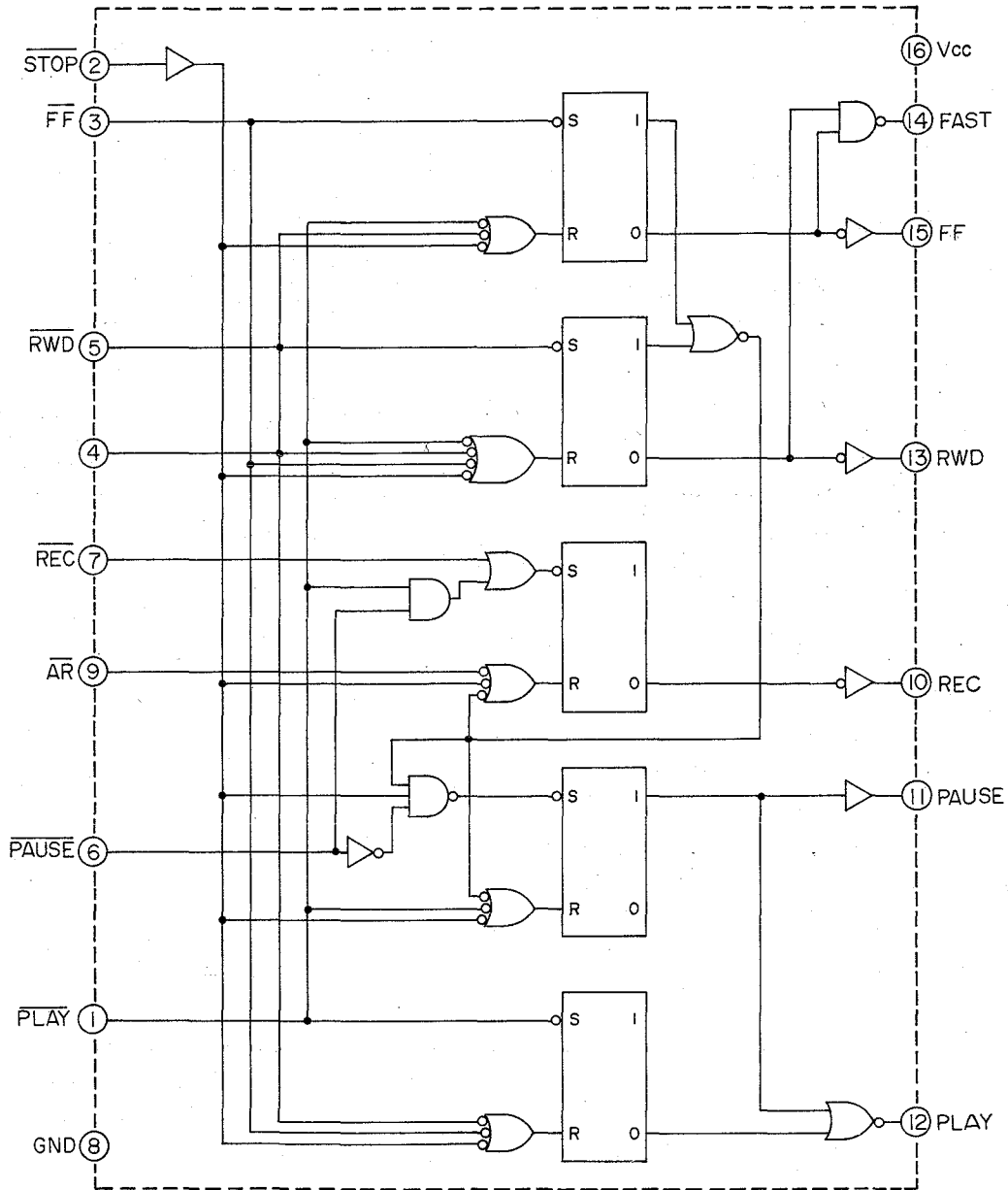

Fig. 18

2) Terminals and their functions

	Terminal Name	Terminal Function
Operation input terminals	$\overline{\text{STOP}}$	Input terminal for stopping operation
	$\overline{\text{FF}}$	Input terminal for fast forward
	$\overline{\text{RWD}}$	Input terminal for rewind
	$\overline{\text{REC}}$	Input terminal for recording
	$\overline{\text{PAUSE}}$	Input terminal for pause
	$\overline{\text{PLAY}}$	Input terminal for playback
Control input terminal $\overline{\text{AR}}$		Input terminal for preventing recording
Output terminals	FAST	Terminal with "H" signal output during fast forward or rewind mode
	FF	Terminal with "H" signal output during fast forward mode
	RWD	Terminal with "H" signal output during rewind mode
	REC	Terminal with "H" signal output during REC/PLAY or REC/PAUSE mode
	PAUSE	Terminal with "H" signal output during pause mode
	PLAY	Terminal with "H" signal output during playback mode

Chart-1

3) Operation activated by each input

Input Signal	Output						Output Mode
	FAST	FF	RWD	REC	PAUSE	PLAY	
$\overline{\text{STOP}}$	L	L	L	L	L	L	STOP Mode
$\overline{\text{FF}}$	H	H	L	L	L	L	FF Mode
$\overline{\text{RWD}}$	H	L	H	L	L	L	RWD Mode
$\overline{\text{PLAY}}$	L	L	L	L	L	H	PLAY Mode
$\overline{\text{PAUSE}}$	L	L	L	L	H	L	PAUSE Mode
$\overline{\text{REC/PLAY}}$	L	L	L	H	L	H	REC/PLAY Mode
$\overline{\text{REC/PAUSE}}$	L	L	L	H	H	L	REC/PAUSE Mode

Chart-2

- NOTES:**
1. The input signal is activated by the fall of .
 2. The output is maintained until the next input signal.
 3. $\overline{\text{AR}}$ is a control input terminal and the REC output is not "H" when $\overline{\text{AR}} = \text{"L"}$.
 4. When $\overline{\text{AR}} = \text{"L"}$ signal is supplied during the REC output is "H", REC output becomes "L".
 5. At the moment the power goes on, all output will be "L" and the Stop mode will be effected.

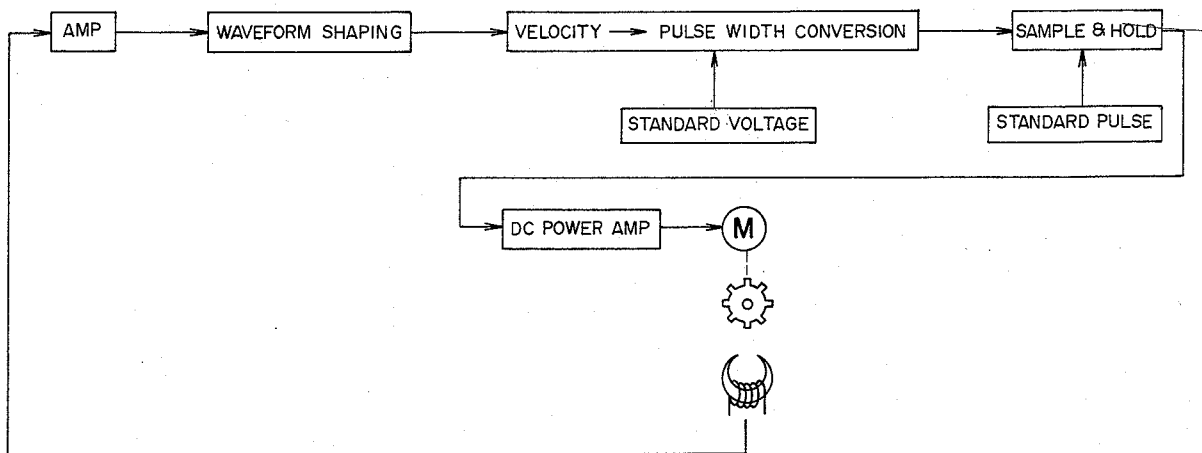

Fig. 19 Block Diagram

11. THE SAMPLE AND HOLD SYSTEM SERVO MOTOR (SCM-200) OPERATION

1) Servo signals generally created proportionate to the number of revolutions of the motor are shown either as frequency deviations or voltage deflections. The motor employed in GX-625 uses frequency deviation unaffected by time constants, etc., of the load circuit as input signal to the motor drive circuit through pulse width conversion.

This pulse width varies proportionately to the deviations in the number of motor rotations. The deviation is detected, converted to a voltage value, is held at that voltage until the next servo signal pulse, and then impressed into the motor drive circuit.

Meanwhile, since it requires a holding circuit and because 112 pulses are generated for each motor rotation, time constants of circuits coming before the Sample and Hold circuit can be greatly reduced compared to the conventional voltage deflection detection system.

For the reasons above, it features quick response to motor revolutions, minimum influence by temperature, and fewer chances of faulty mechanism. In addition, due to the inclusion of the servo voltage holding circuit, ripple content of the servo voltage has been sharply reduced to result in a smooth and stable tape transport with a minimum of wow & flutter.

2) Explanation of the circuit operation (Refer to Figs. 20, 21)

The velocity signal obtained from the motor's frequency generator is shaped into a waveform in the period of "T" proportionate to the velocity as

in (a) on collector TR6. This signal is differentiated and enters TR7 base. This makes TR7's collector output as in (c) and turns ON TR11 during the time of the negative pulse.

Meanwhile TR8 base is supplied with a waveform like (d) and when it reaches the threshold level. TR8 is turned on. A waveform (e) with pulse width " t_1 " is obtained from the collector. During the time "T" that TR8 is ON, TR10 base electric potential decreases to turn ON.

Consequently, TR9 base electric potential increases and TR9 is also turned ON for the time " t_1 ".

When the period "T" varies with the velocity, the pulse width " t_1 " varies according to TR8's threshold level. But when TR11 is on, it is constant due to the time constant. So that by using the period that TR11 is ON as the standard pulse, the pulse width " t_2 " is constant regardless of the velocity.

(g) and (h) show the ON and OFF condition of TR11 and TR9.

When the electric charge that was charged to C16 is discharged during the time TR9 is ON " t_1 ", a signal voltage of "e" proportionate to the velocity can be obtained. Next, with "e" as its basis, C16 is charged during the limited time of the standard pulse width " t_2 ", and by the charging voltage "e" the charging is stopped. The voltage is then held until the next standard pulse.

This voltage "e" is supplied to the TR12 base and a servo signal "E" is obtained. This servo signal "E" controls TR13 and drives the motor. As shown above, since " t_1 " and " t_2 " are small, servo signal ripples decreased and a near direct current servo signal is obtained.

In addition, the time constants of the smoothing circuit can also be decreased so that phase lag factor can be minimized.

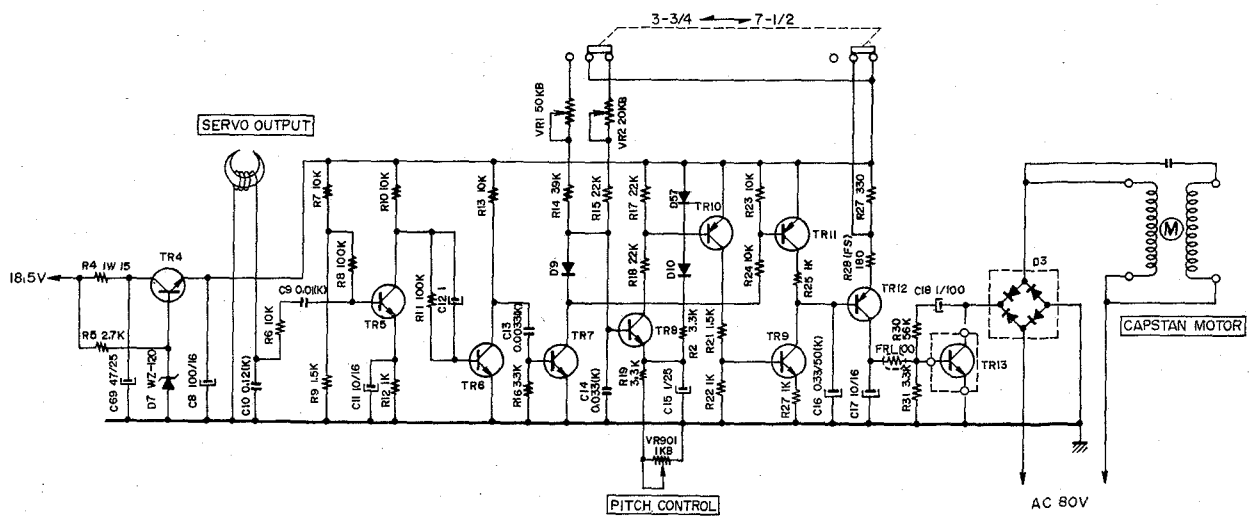

Fig. 20

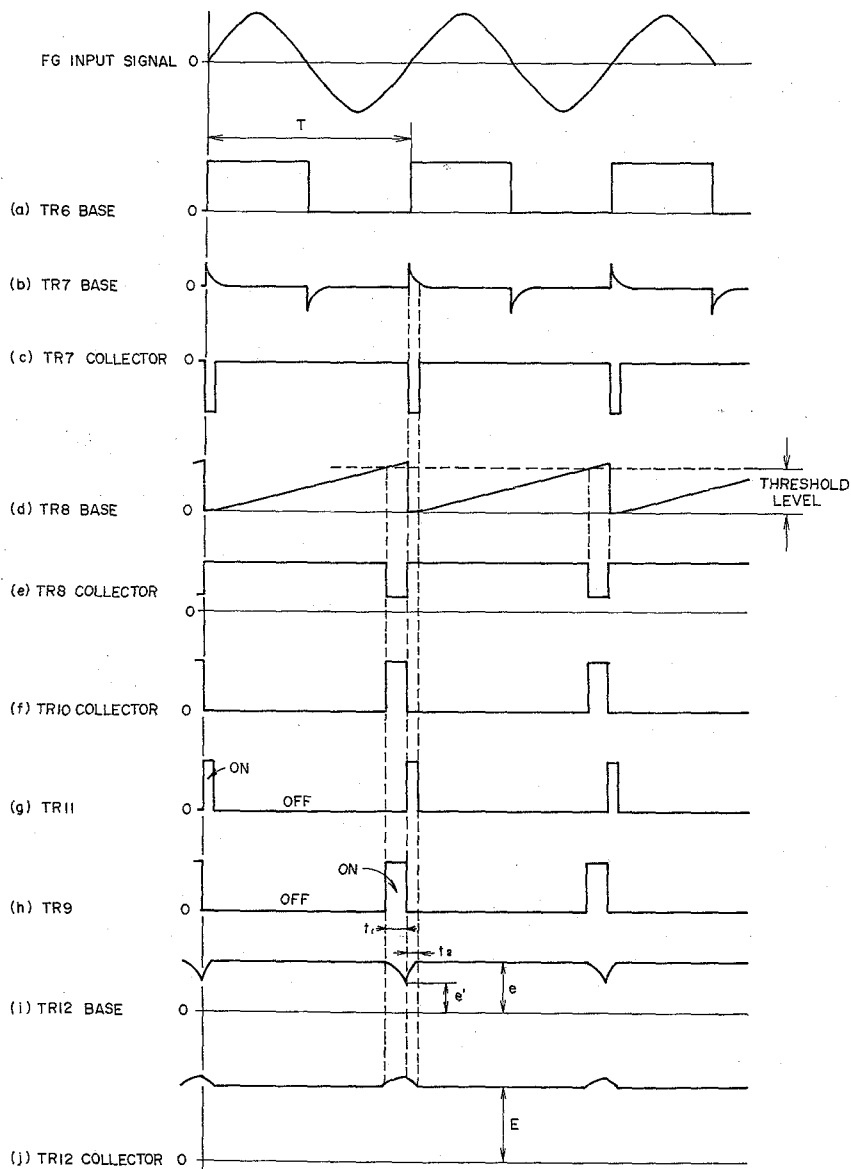

Fig. 21

VII. MECHANISM ADJUSTMENT

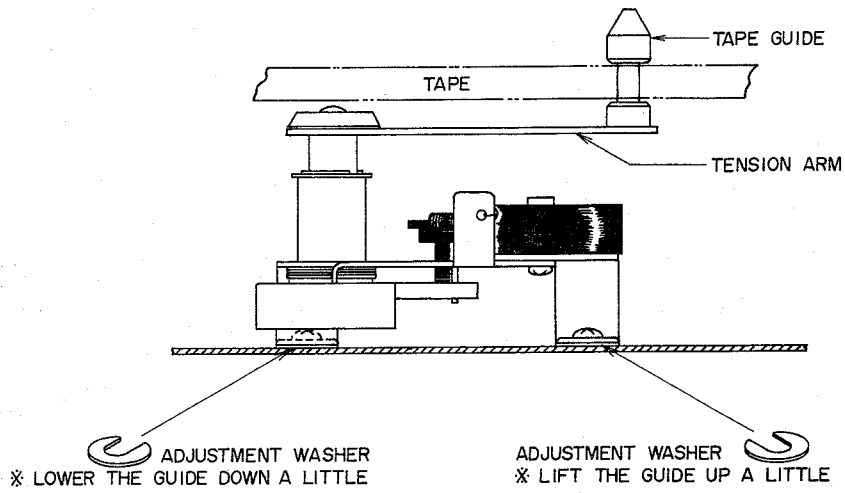

Fig. 22

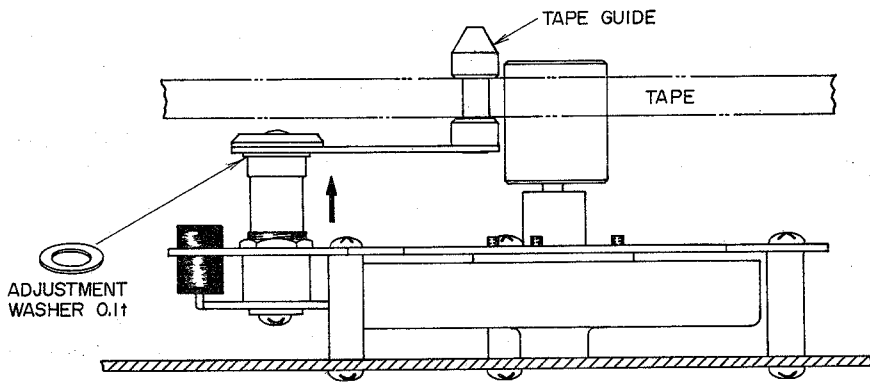

Fig. 23

1. TAPE GUIDE HEIGHT ADJUSTMENT (Refer to Figs. 22, 23)

Adjust tape guide height so that the tape does not curl between the tape guide and guides on head base. As left and right tape guide height adjustment methods are different, be sure to refer to Figs. 22 and 23.

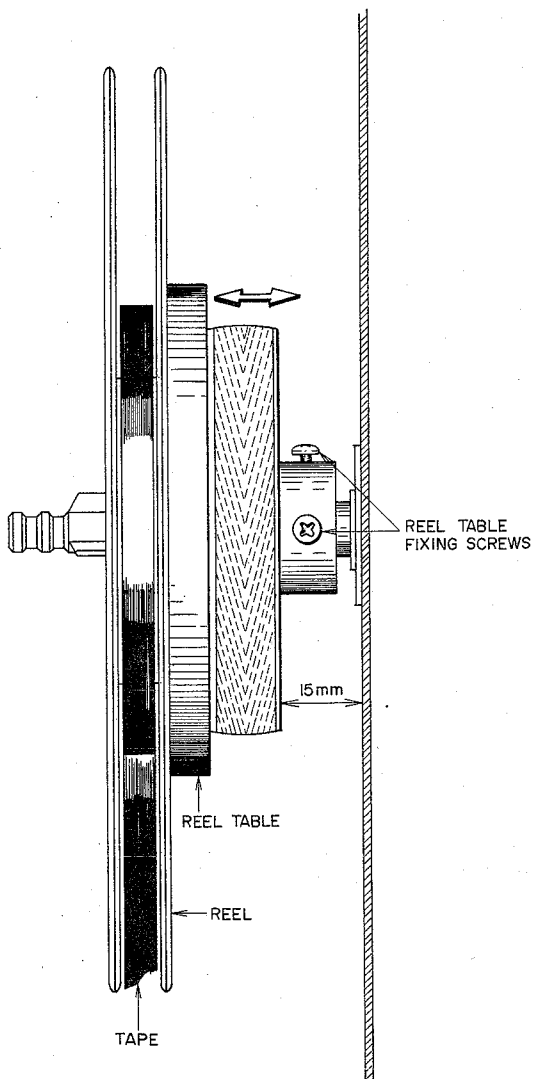

Fig. 24

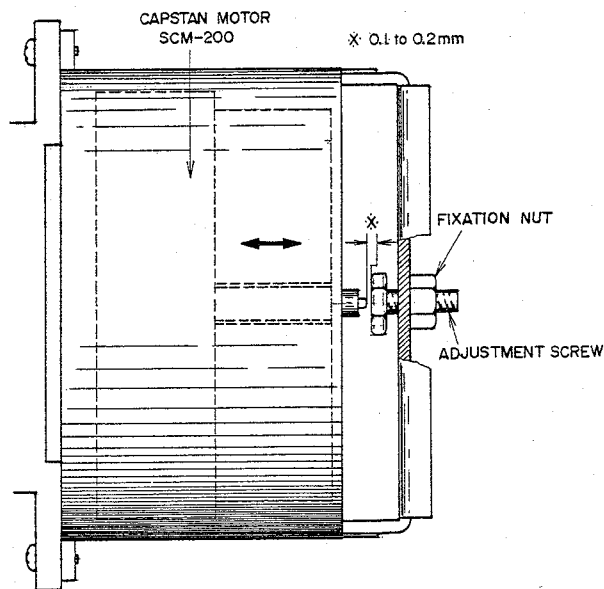

Fig. 25

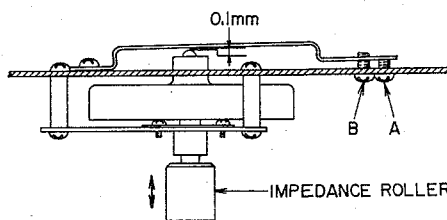

Fig. 26

2. REEL TABLE HEIGHT ADJUSTMENT

(Refer to Fig. 24)

- 1) Temporarily screw in the fixing screws leaving a gap of 15 mm between the reel table and the chassis board.
- 2) Run the tape and adjust the height of the reel table so that the tape is taken up in the center of the reel. Tighten fixing screws. Adjust the height of the right reel table at fast forward, of the left reel table at rewind.

3. CAPSTAN SHAFT LOOSEN PLAY

ADJUSTMENT (Refer to Fig. 25)

Adjust by turning Adjustment Screw to obtain a 0.1 to 0.2 mm degree of loose play when the capstan shaft is moved as indicated by the arrow mark. Tighten fixation nut to maintain optimum adjusted condition.

4. IMPEDANCE ROLLER LOOSE PLAY

ADJUSTMENT (Refer to Fig. 26)

Adjust Screws A and B so that impedance roller loose play is 0.1 mm. Confirm that the screws are tight following this adjustment.

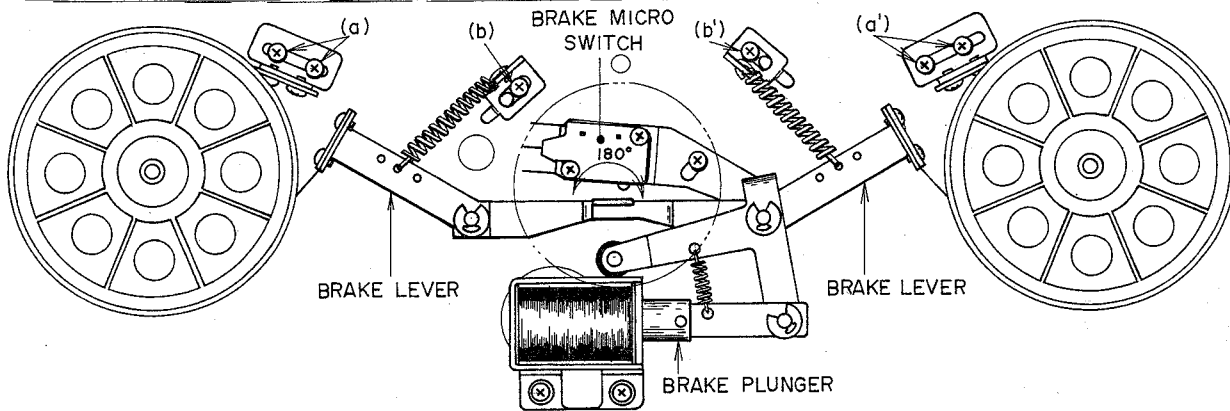

Fig. 27

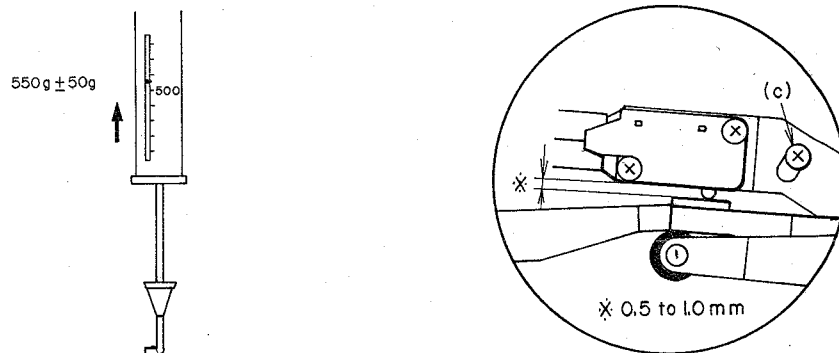

Fig. 29

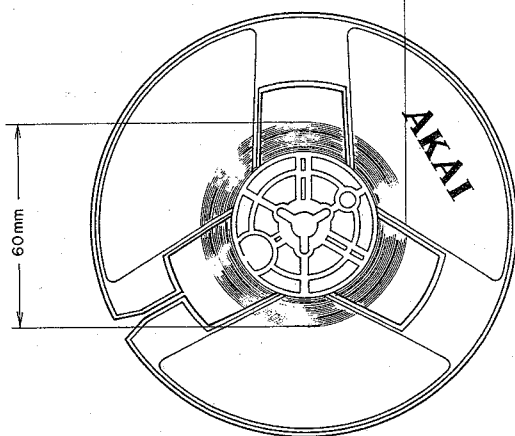

Fig. 28

5. BRAKE BAND POSITION ADJUSTMENT AND BRAKE TENSION ADJUSTMENT (Refer to Figs. 27 to 29)

- 1) Adjust the brake lever to 180° position by loosening the screws (a) and (a').
- 2) Work the brake plunger to check that the brake band is not slanted.
- 3) Adjust the position of the part with screws (b) and (b') to obtain a brake tension of 550 ± 50 g on both brakes at stop mode.
(Use a 1,000 g spring gauge for a reel with 60 mm diameter of tape.) In case the specified brake tension cannot be obtained, connect the springs to the other holes on the brake lever and adjust.
- 4) By working the brake plunger with a finger, adjust the position of the microswitch screw (c) so that the gap between the brake lever and the microswitch body is 0.5 to 1.0 mm.

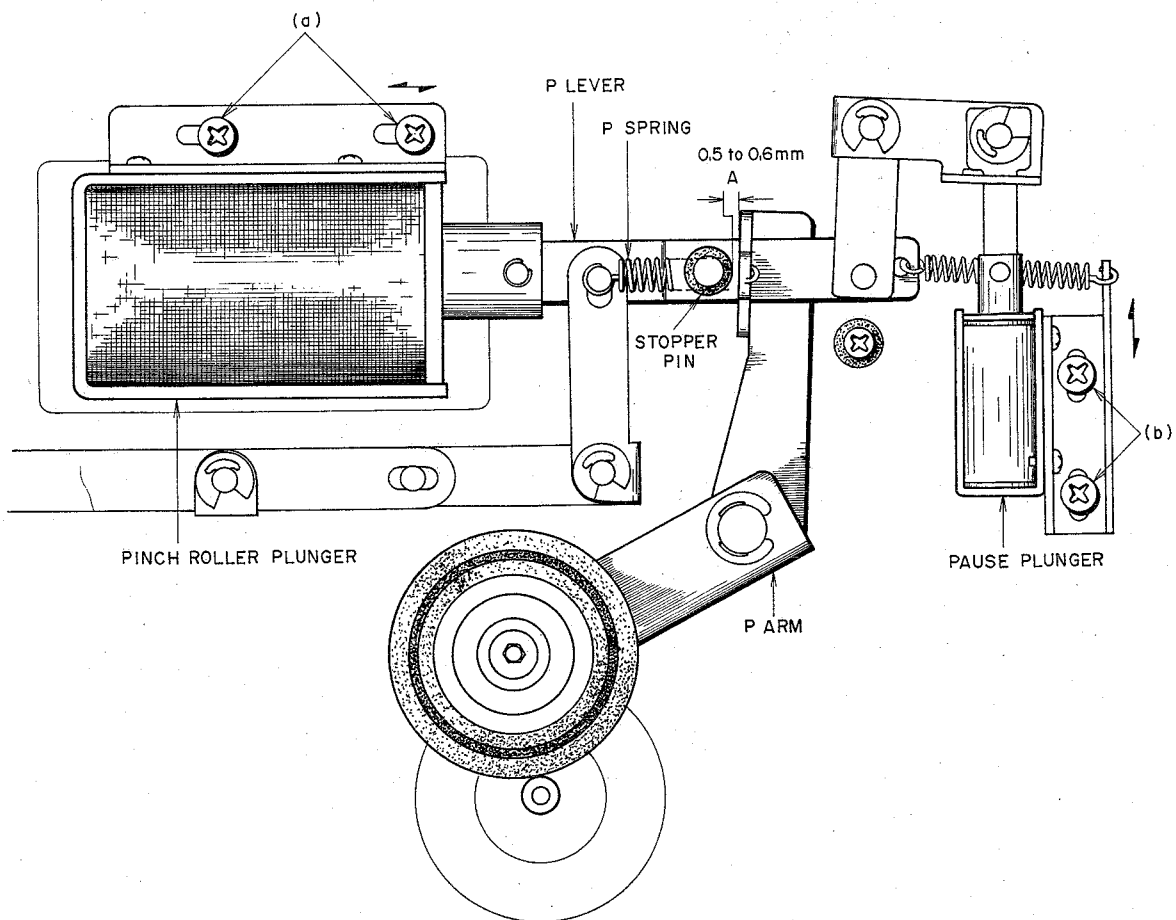

Fig. 30

**6. PINCH ROLLER PLUNGER
INSTALLATION POSITION AND PINCH
ROLLER PRESSURE ADJUSTMENT**

(Refer to Fig. 30)

- 1) While in the play mode, adjust the position of pinch roller plunger by means of screw (a) until the gap (Fig. 30A) between P arm and the rubber part of stopper pin becomes 0.5 to 0.6 mm.
- 2) Connect a 2 kg spring gauge to the pinch roller fixing screw. Pull up the pinch roller and then let it slowly move back. Check that the spring gauge reads $1.2 \text{ kg} \pm 100 \text{ g}$ at the moment the pinch roller touches the capstan and starts rolling. If the specified pressure cannot be obtained, adjust gap A by positioning the pinch roller plunger or replace the P spring, so as to attain the specified pressure.

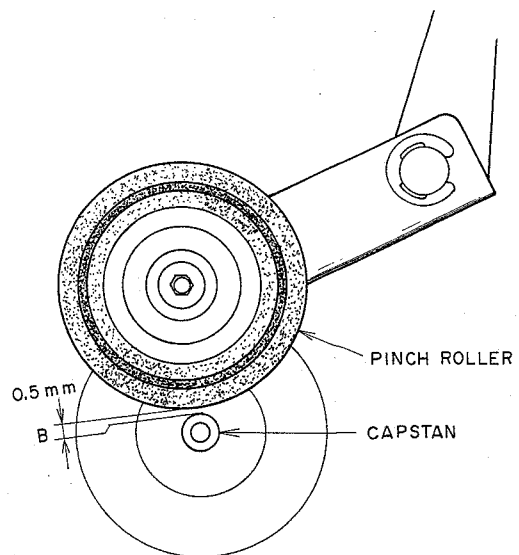

Fig. 31

**7. PAUSE PLUNGER POSITION
ADJUSTMENT (Refer to Figs. 30, 31)**

At the pause mode, the gap between the capstan and the pinch roller should be 0.5 mm. Adjust the pause plunger position with screws (b).

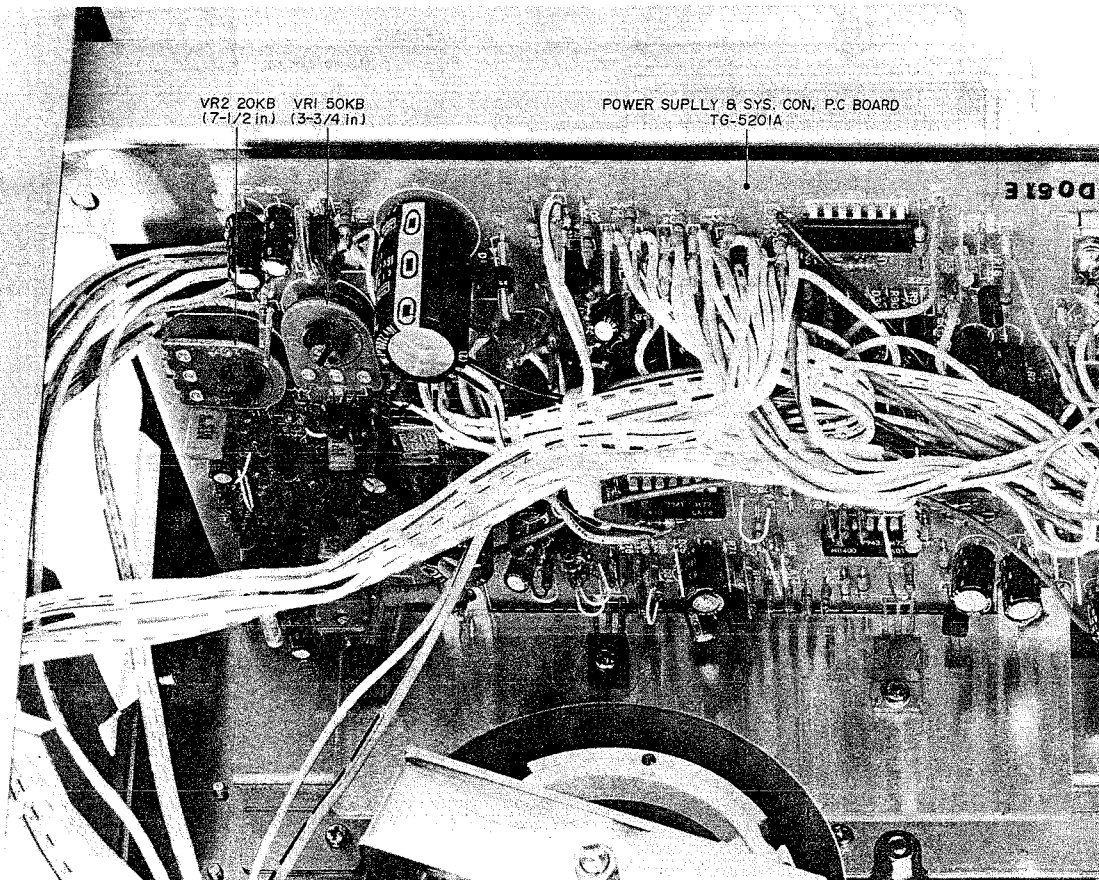

Fig. 32

8. TAPE SPEED ADJUSTMENT

(Refer to Fig. 32)

Set the Tape Speed Switch to 7-1/2 ips and playback the 1,000 Hz, 7-1/2 Test tape. Connect a frequency counter to LINE OUT and adjust VR2 20 kB until the counter reads 1,000 Hz \pm 0.5%.

Next, set the Tape Speed Switch to 3-3/4 ips and adjust VR1 50 kB until the frequency counter reads 500 Hz \pm 0.5%.

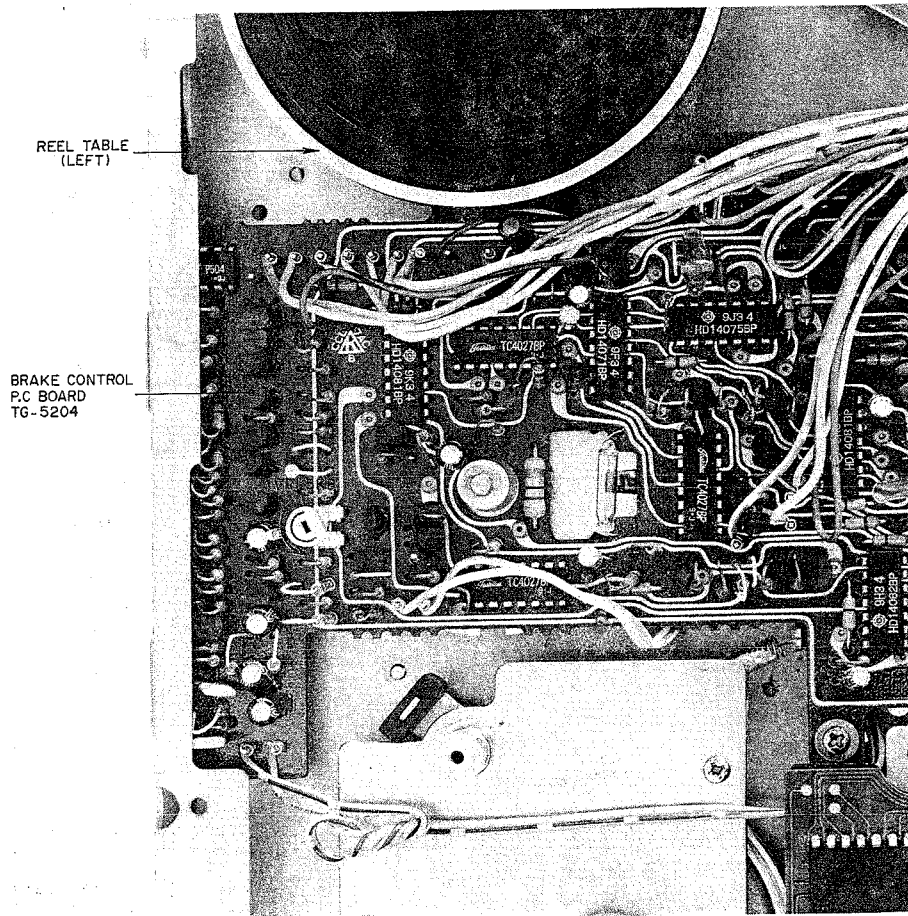

Fig. 33

9. SERVO BRAKE ADJUSTMENT

1) Tape run must stop completely at "0" on the tape counter from RWD when the AUTO SYSTEM (repeat, play and stop) is activated.

* Tape RWD from a point below "9" on the tape counter can not be adjusted if it does not stop at "0" because the servo brake has not been activated.

2) Refer to VI item 7 for VR5.

3) Adjustment Method

- a. Put on a 10" reel and set the reel size selector to 10 in. (A reel with hole as used for turning the volume below may be used.)
- b. Depress the counter and auto system stop buttons.
- c. Reset the tape counter and fast forward to about "35".

d. Turn VR1 5 kB counter-clockwise 20° to 30° from its present position.

e. Put in the RWD mode. (Brakes at "29" and "9" on the tape counter and if this brake is too strong, tape run is reversed and goes into FF.)

f. While returning VR1 little by little in a clockwise direction, repeat RWD many times from "35" on the tape counter and set the volume where tape run does not reverse and stops at "0". The brake is too strong if the tape seems to stop momentarily even if it is not reversed.

g. Rewind from about "20", "35" and "100" on the tape counter and confirm that it completely stops at "0". There are differences caused by the amount of tape on the reels so please check in many positions.

h. Put on a 7" reel and check operation.

VIII. HEAD ADJUSTMENT

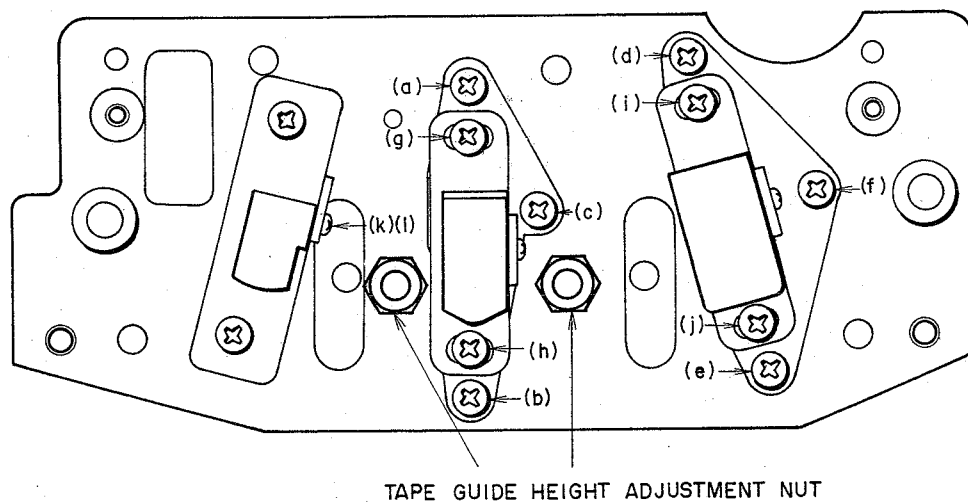

Fig. 34

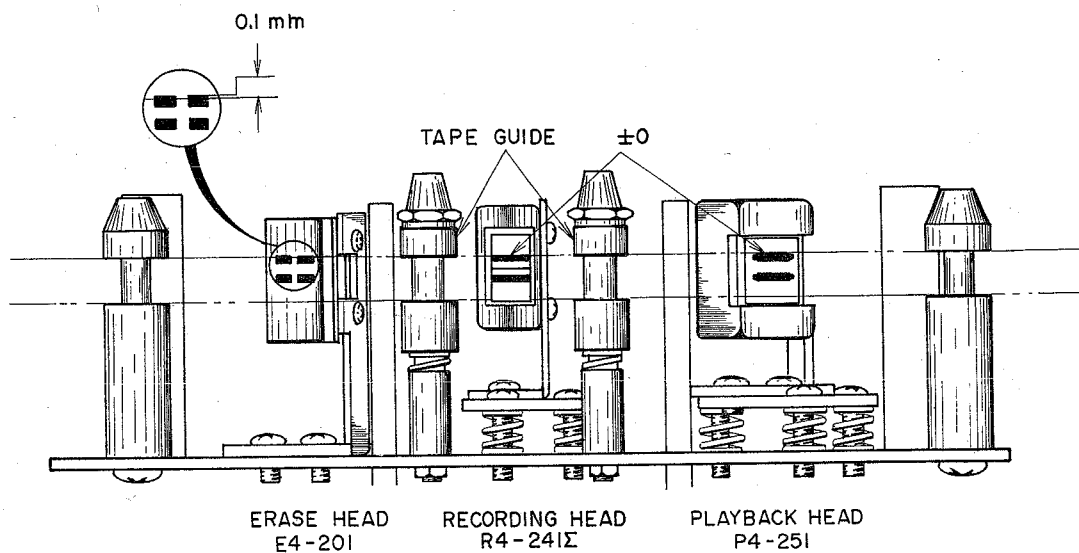

Fig. 35

Step	Adjustment Item	Test Tape Supply Signal	Mode	Adjustment Point	Remarks
1	Tape Guide Height	Optional	Play	Tape Guide Height Adjustment Nut	Adjust so that tape travels smoothly and does not twist.
2	Erase Head Height	Optional	Play	(k) (l)	Upper edge of Left Ch. head core is 0.1 mm higher than upper edge of tape.
3	Recording Head Height	Optional	Play	(a) (b) (c)	Upper edges of Left Ch. head core and tape are the same height. (Refer to NOTE 6.)
4	Playback Head Height	Optional	Play	(d) (e) (f)	Upper edges of Left Ch. head core and tape are the same height. (Refer to NOTE 6.)
5	Playback Head Azimuth Alignment	8,000 Hz 3-3/4 ips Test Tape	Play	(f)	Maximum output, both channels.
6	Playback Head Angle Alignment	8,000 Hz 3-3/4 ips Test Tape	Play	(i) (j)	Adjust head gap surface so that there is no change in output level when tension is applied to the supply reel side.
7	Recording Head Azimuth Alignment	Scotch #176 Tape 15,000 Hz -20 dBm	REC	(c)	Maximum output, both channels.
8	Recording Head Angle Alignment	Scotch #176 Tape 15,000 Hz -20 dBm	REC	(g) (h)	Adjust head gap surface so that there is no change in output level when tension is applied to the supply reel side.

Chart-3

- NOTES:**
- As perfect head adjustments are vital to tape deck performance, be sure that these adjustments are carried out properly.
 - Be careful not to use a magnetized driver or other magnetized tools in the vicinity of the heads.
 - Use only new tape as level variation is likely to occur when using old tape.
 - Demagnetize heads with head demagnetizer before and after head adjustment.
 - Set tape speed to 7-1/2 ips.
 - Simultaneously adjust the front and back tilts of head until uniform contact is ensured between the tape and the surface of head.

IX. AMPLIFIER ADJUSTMENT

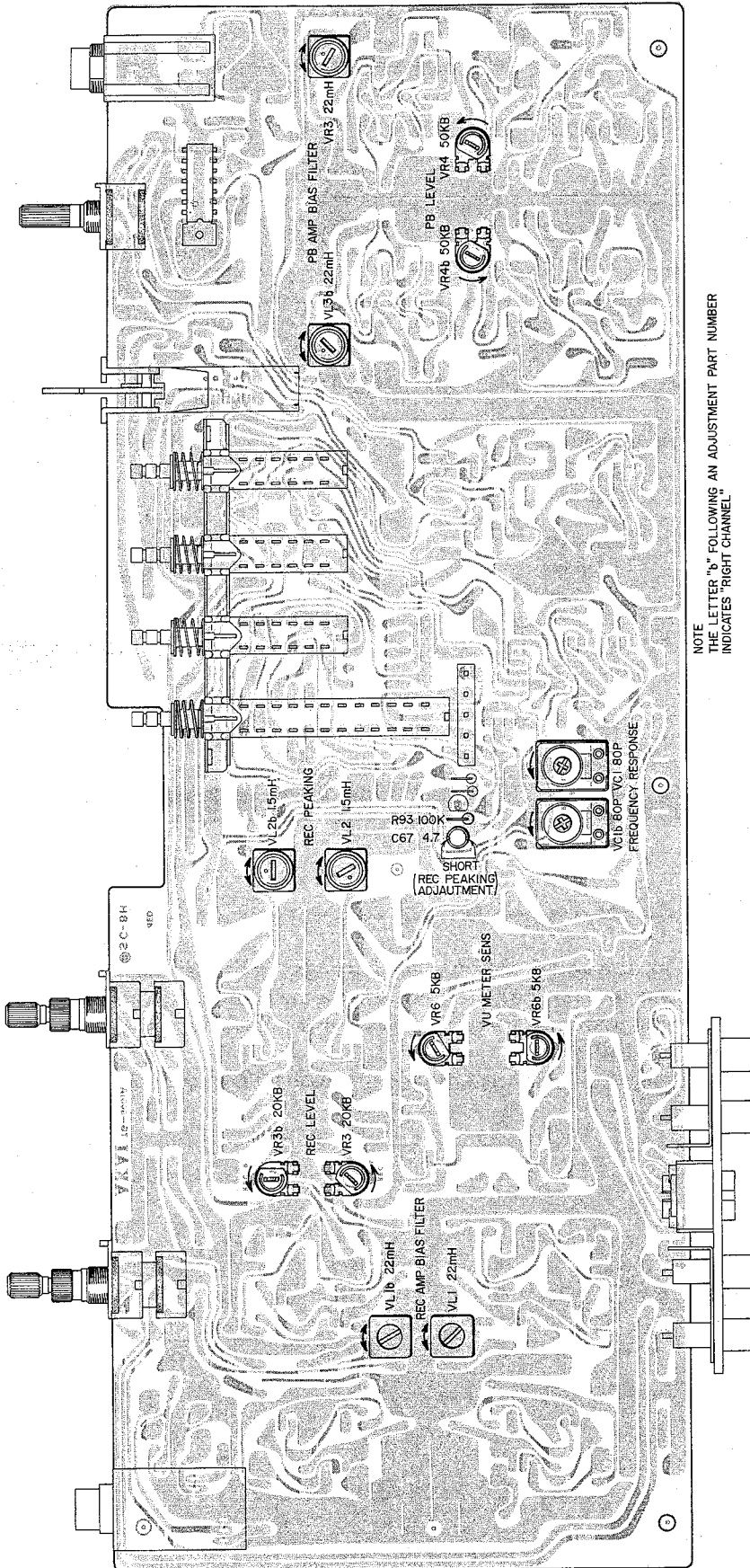

Fig. 36 Pre Amp P.C Board TG-5001A

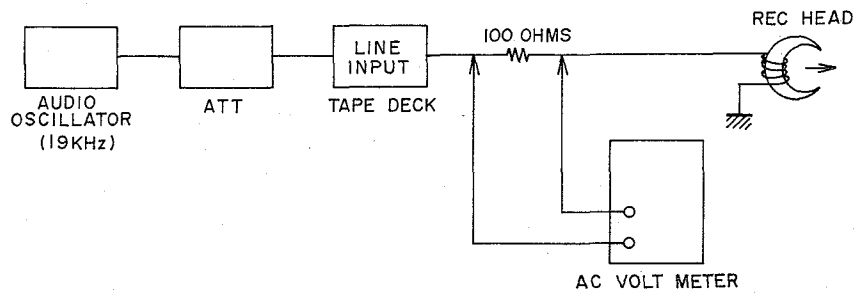

Fig. 37 Rec Peaking Adjustment Instrument Connection

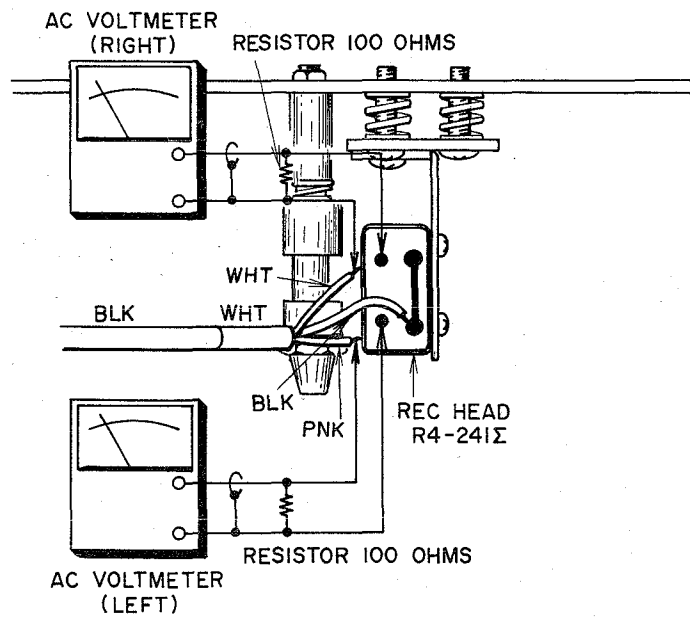

Fig. 38 Rec Peaking Adjustment

Step	Adjustment Item	Test Tape Supply Signal	Mode	Adjustment Point	Result	Remarks
1	Playback Level	700 Hz 7-1/2 ips 0VU Test Tape	Play	VR 4 50 kB	0 ± 0.5 dBm (0.775V)	
2	VU Meter Sensitivity	700 Hz 7-1/2 ips 0 VU Test Tape	Play	VR 6 5 kB	0VU indication	
3	REC Peaking	19 kHz from an oscillator	REC	VL 2 1.5 mH	Maximum AC Voltmeter indication	Tape Speed 3-3/4 ips. Refer to NOTE 4, 5, 7 and Figs. 36, 37, 38.
4	Recording Level	Scotch #176 Tape 1,000 Hz 0 dBm Recording	REC	VR 3 20 kB	0 ± 0.5 dBm (0.775V)	
5	Frequency Response (3-3/4 ips)	Scotch #176 Tape 1.5 kHz, 15 kHz -20dBm Recording	REC	TC 1 80 P	1.5 kHz 15 kHz flat	Tape Speed 3-3/4 ips. Recheck Recording Level.
6	Distortion Confirmation	Scotch #176 Tape 1,000 Hz 0 dBm Recording	REC		Less than 0.5%	See NOTE 6.
7	PB Amp Bias Filter	100 kHz from an oscillator	REC	VL 3 22 mH	Minimum AC Voltmeter indication	Set Monitor Switch to "TAPE". See NOTE 7, 8.
8	REC Amp Bias Filter	100 kHz from an oscillator	REC	VL 1 22 mH	Minimum AC Voltmeter indication	Set Monitor Switch to "SOURCE". See NOTE 7, 8.

Chart-4

- NOTES:**
1. Output Level Control should be at maximum.
 2. Except for Step 3 and 5, set Tape Speed to 7-1/2 ips.
 3. Set Tape Selector Switch to Low Noise position.
 4. Stop recording bias oscillator while making Rec Peaking Adjustment. (Refer to Fig. 36)
 5. When 19 kHz indicates the peak, check and ensure that the AC voltmeter shows 16 dB of increase when 15 kHz of input is fed rather than when 1 kHz is fed.
 6. If it does not comply with the specifications, repeat Steps 4 and 5, and re-adjust.
 7. Unless the core is moved intentionally this adjustment is not necessary.
 8. Adjust the oscillator's frequency to give a frequency counter reading of 100 kHz.

X. DC RESISTANCE OF VARIOUS COILS

Part	Designation	DC Resistance
Main Motor	SCM-200	Between BLU-RED : 110 ohms Between YLW-BRN : 170 ohms Pick-up Coil : 665 ohms
Reel Motor	20XO-TD	Between BLU-RED : 30 ohms Between YLW-BRN : 157 ohms
Pinch Roller Plunger	1664PLTI	600 ohms \pm 10%
Brake Plunger	1240PLTI	600 ohms \pm 10%
Pause Plunger	0730FLT	600 ohms \pm 10%
Relay	MY4-02-US-L	650 ohms \pm 15%
Relay	BR211	1,280 ohms \pm 10%
Relay	LAB2NS	1,750 ohms \pm 10%
Relay	321D012	230 ohms \pm 15%
Erase Head	E4-201	1.8 ohms
Recording Head	R4-241	5.9 ohms
Playback Head	P4-251	219 ohms \pm 10%

Chart-5

XI. CLASSIFICATION OF VARIOUS P.C BOARDS

1. P.C BOARD TITLES AND IDENTIFICATION NUMBERS

P.C Board Title	P.C Board Number
Pre Amp P.C Board	TG-5001A
LED P.C Board	TG-5001B
Power Supply & Sys. Con P.C Board	TG-5201A
Switch P.C Board	TG-5201B
Fuse P.C Board	TG-5202
Detection P.C Board	TG-5203
Brake Control P.C Board	TG-5204
Counter P.C Board	TG-5205
Thyristor P.C Board	TG-5207
Time IND. P.C Board	TG-5214
Filter P.C Board	TG-5216
Terminal P.C Board	NE-2230

Chart-6

2. COMPOSITION OF VARIOUS P.C BOARDS

1) POWER SUPPLY & SYS. CON P.C BOARD TG-5201A (3ED), SWITCH P.C BOARD TG-5201B (2ED) & TERMINAL P.C BOARD NE-2230

WARNING: Δ INDICATES SAFETY CRITICAL COMPONENTS. FOR CONTINUED SAFETY, REPLACE SAFETY CRITICAL COMPONENTS ONLY WITH MANUFACTURER'S RECOMMENDED PARTS.
 AVERTISSEMENT: Δ IL INDIQUÉ LES COMPOSANTS CRITIQUES DE SÛRETÉ. POUR MAINTENIR LE DEGRÉ DE SÛRETÉ DE L'APPAREIL, NE REMPLACER LES COMPOSANTS DONT LE FONCTIONNEMENT EST CRITIQUE POUR LA SÛRETÉ QUE PAR DES PIÈCES RECOMMANDÉES PAR LE FABRICANT.

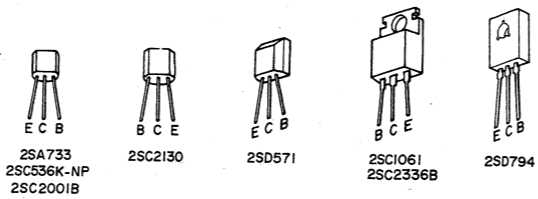

SWITCH P.C BOARD TG-5201B

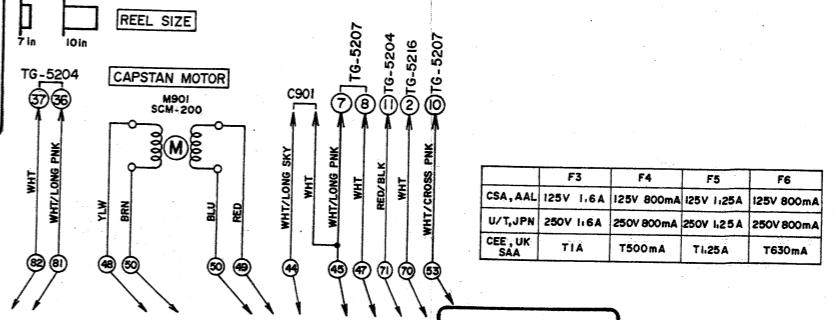
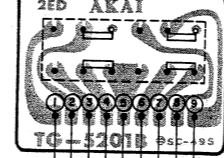

POWER SUPPLY & SYS CON P.C BOARD TG-5201A

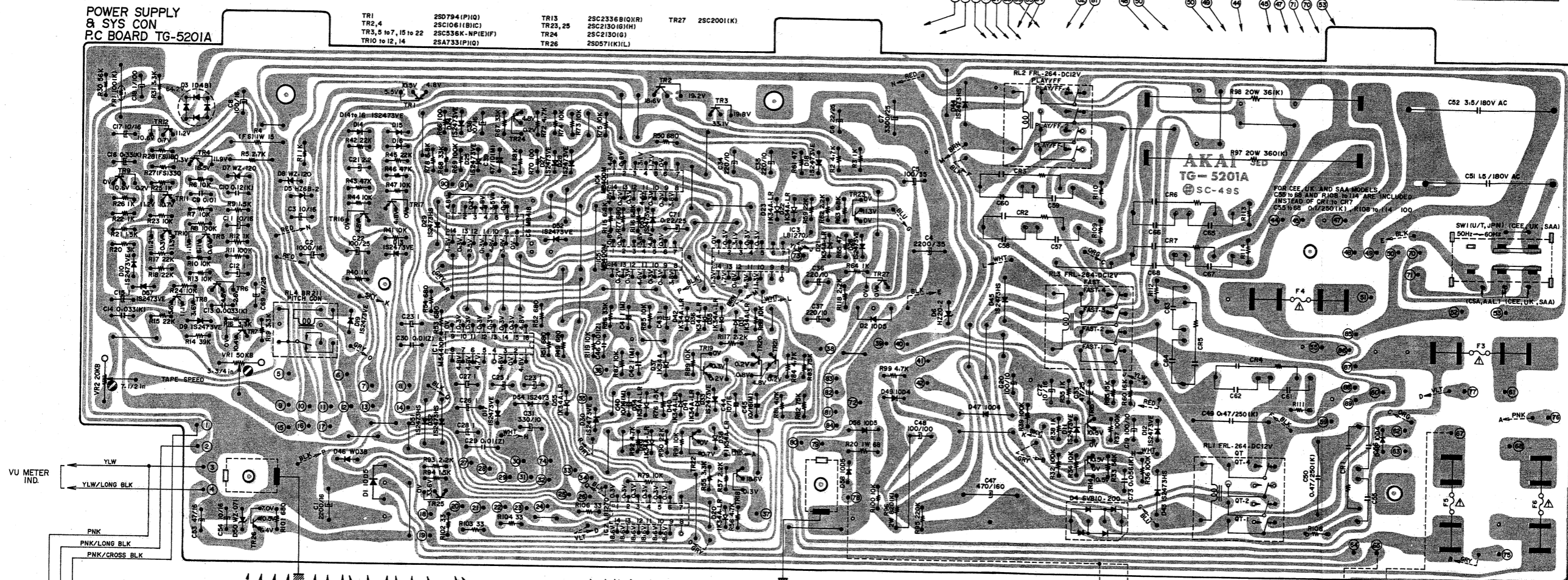
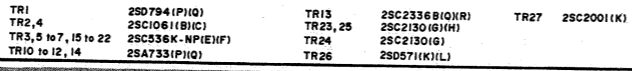

VU METER IND.

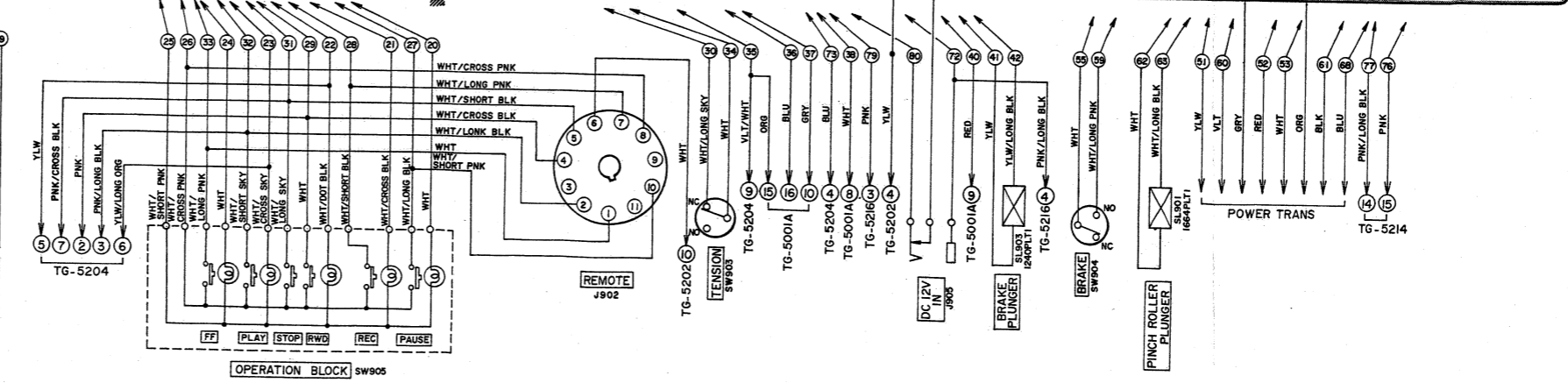
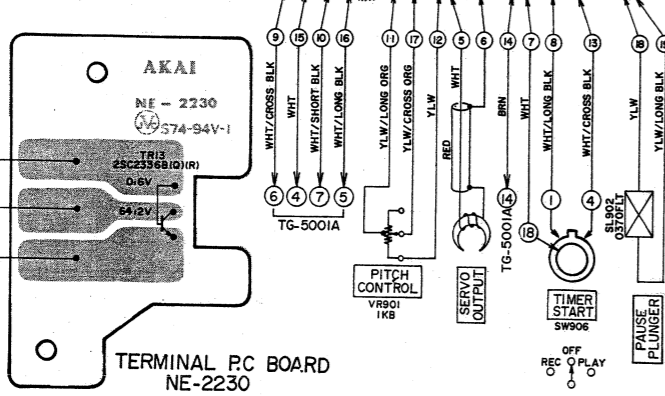

2) PRE AMP P.C BOARD TG-5001A (4ED) & LED P.C BOARD TG-5001B

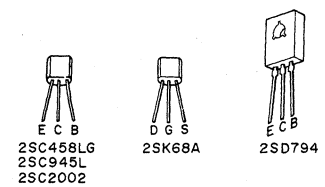
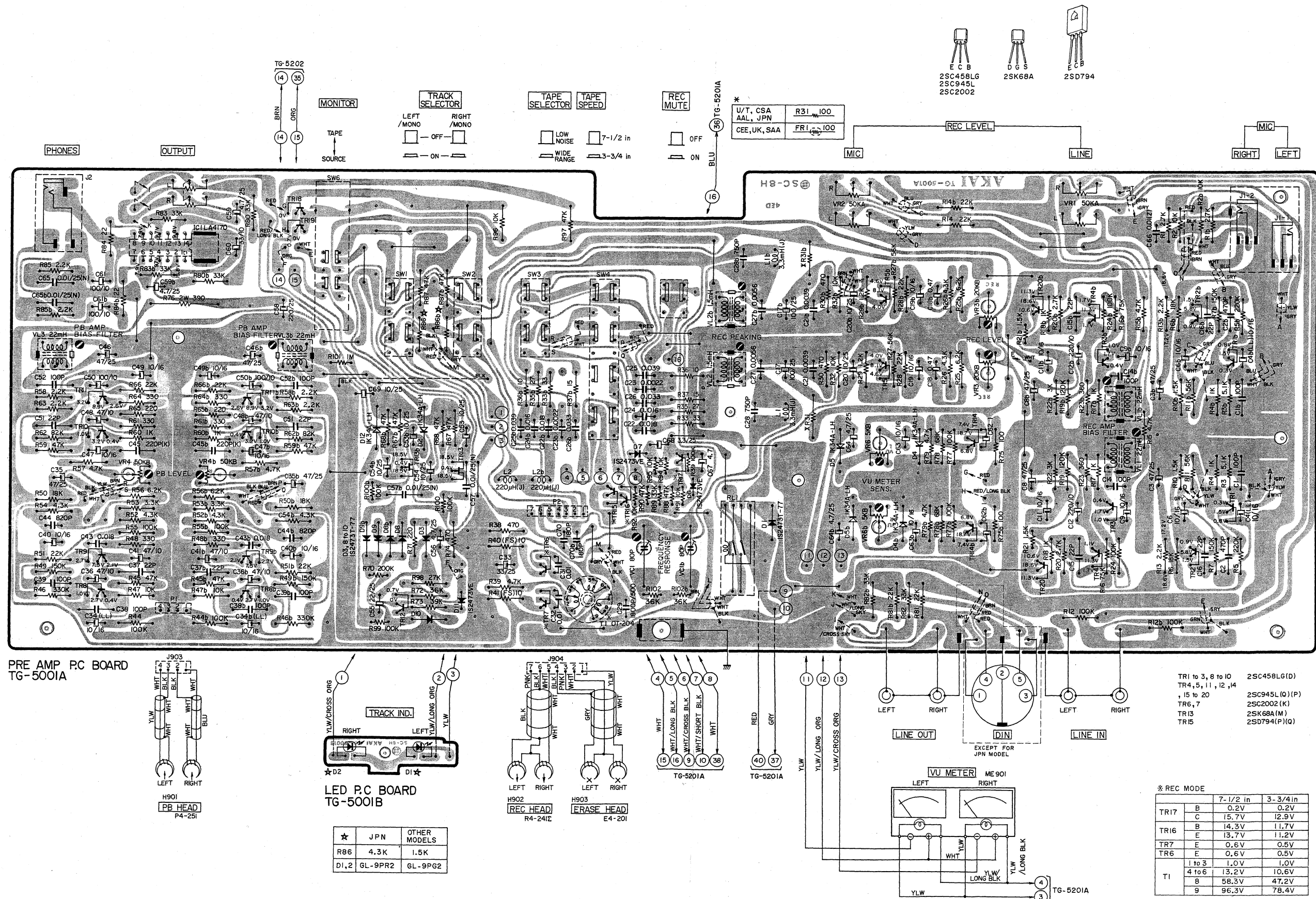

* U/T, CSA AAL, JPN CEE, UK, SAA

R31	100
FRL	100

PRE AMP P.C BOARD TG-5001A

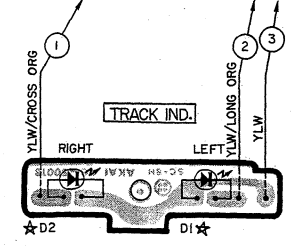
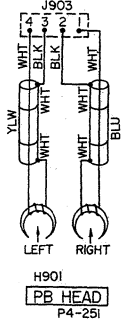

LED P.C BOARD TG-5001B

★	JPN	OTHER MODELS
R86	4.3K	1.5K
D1,2	6L-9PR2	6L-9PG2

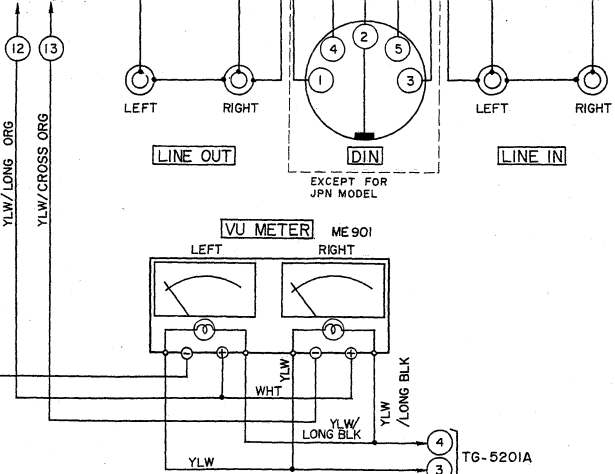
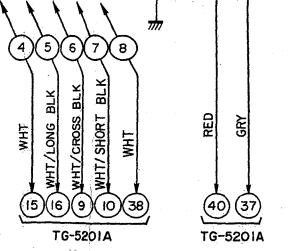
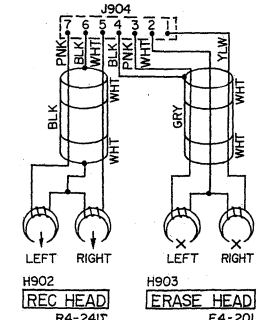

TR1 to 3, 8 to 10	2SC458L(G)(D)
TR4, 5, 11, 12, 14, 15 to 20	2SC945L(Q)(P)
TR6, 7	2SC2002(K)
TR13	2SK68A(M)
TR15	2SD794(P)(Q)

* REC MODE

		7-1/2 in	3-3/4 in
TR17	B	0.2V	0.2V
	C	15.7V	12.9V
	F	14.3V	11.7V
TR16	B	13.7V	11.2V
	F	0.6V	0.5V
	F	0.6V	0.5V
TR6	1 to 3	1.0V	1.0V
	4 to 6	13.2V	10.6V
	B	58.3V	47.2V
T1	B	58.3V	47.2V
	9	96.3V	78.4V

3) BRAKE CONTROL P.C BOARD TG-5204 (3ED) & DETECTION P.C BOARD TG-5203

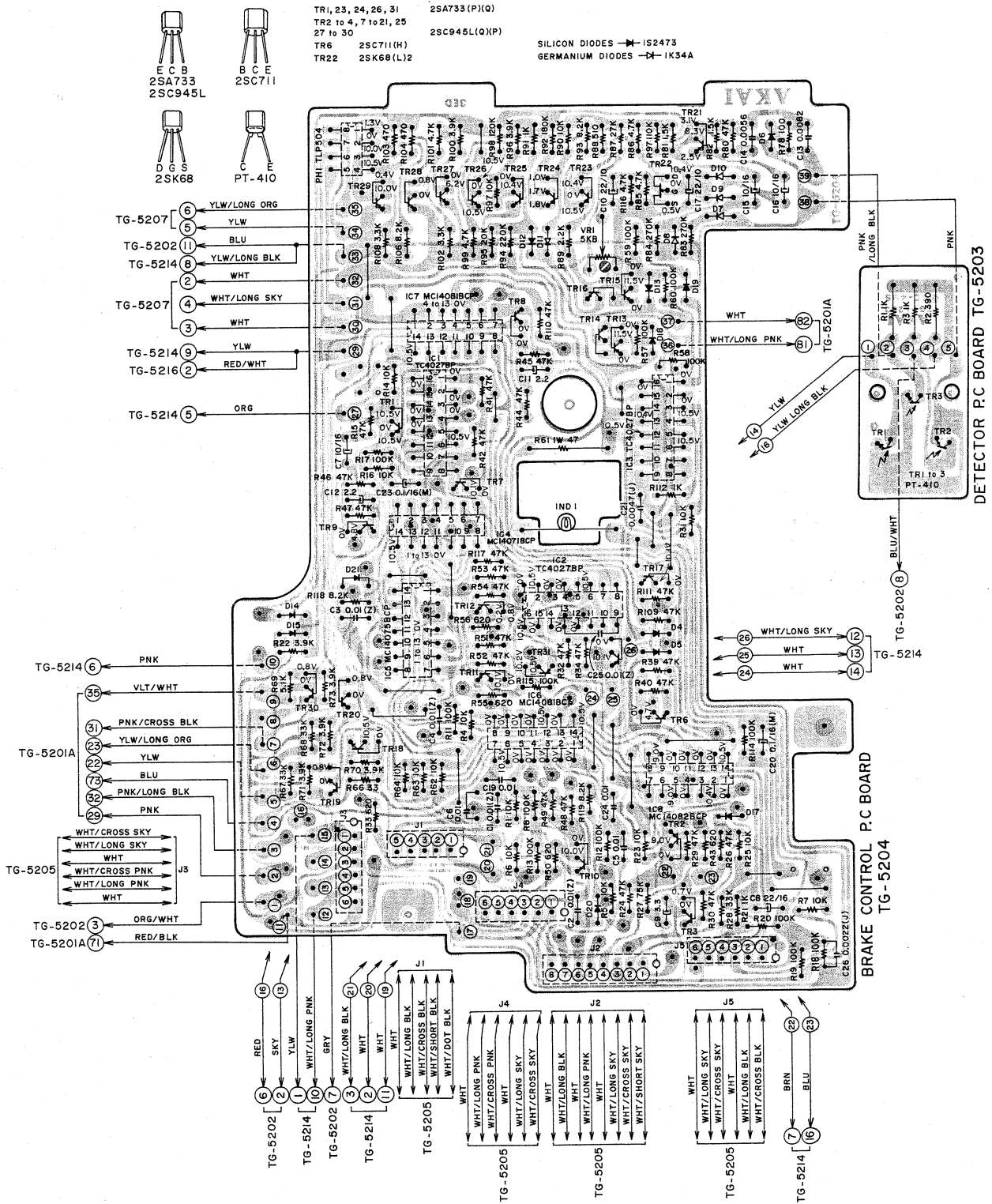

4) COUNTER P.C BOARD TG-5205 (2ED)

Due to a difference in Brake Control P.C Board edition numbers, there are alternative ways of connecting J5. Please pay special attention to connections when changing P.C Boards.

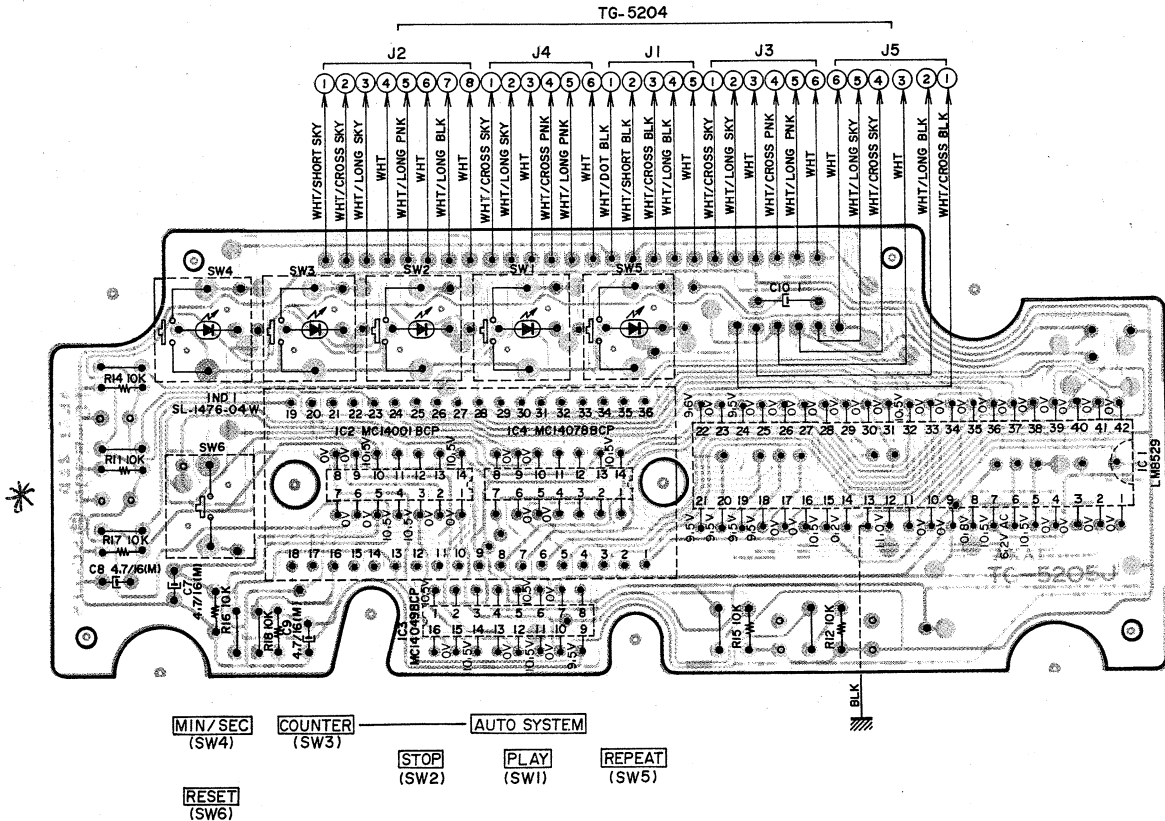
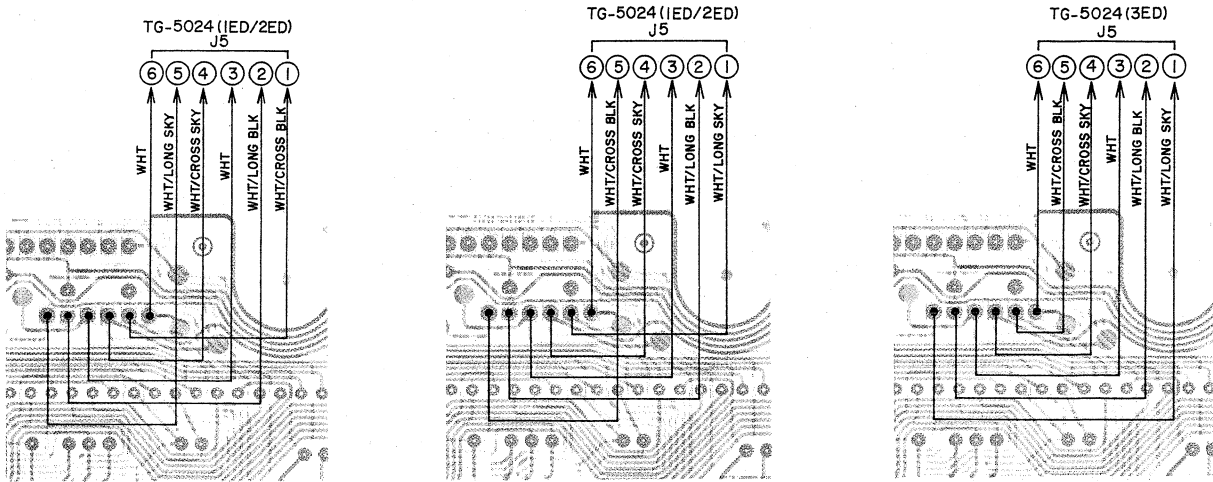

5) THYRISTOR P.C BOARD TG-5207 (4ED)

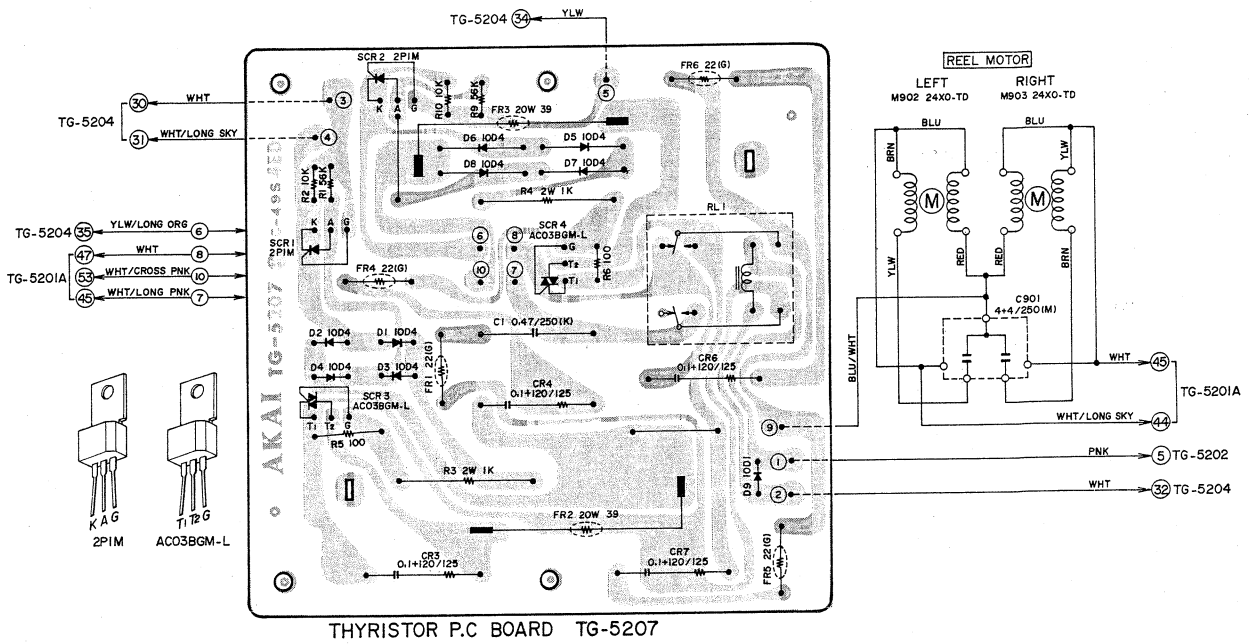

6) TIME IND. P.C BOARD TG-5214 (3ED)

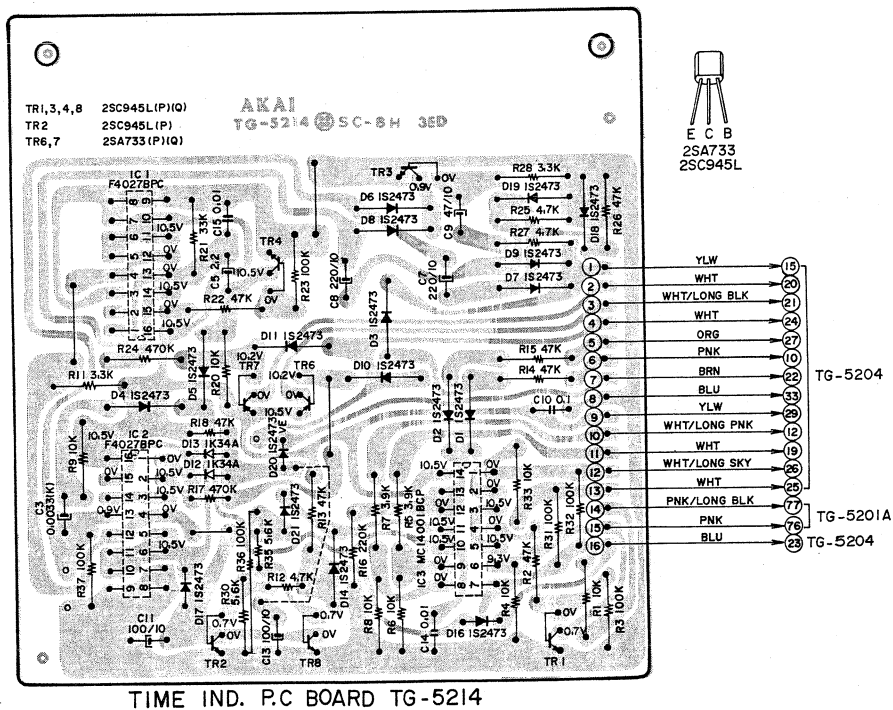

7) FILTER P.C BOARD TG-5216 (3ED)

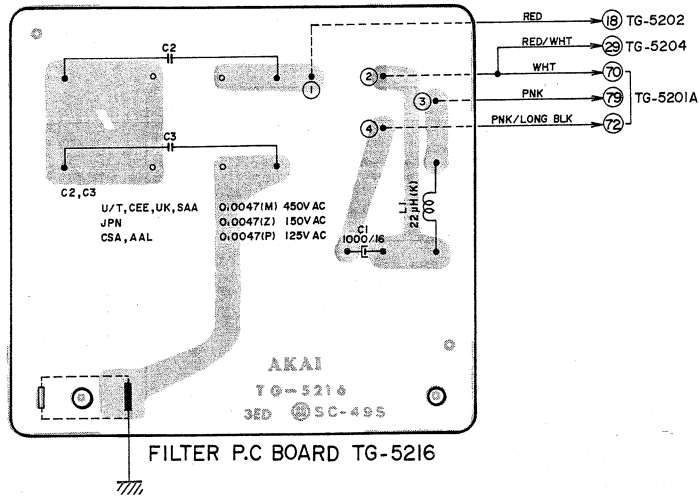

8) FUSE P.C BOARD TG-5202

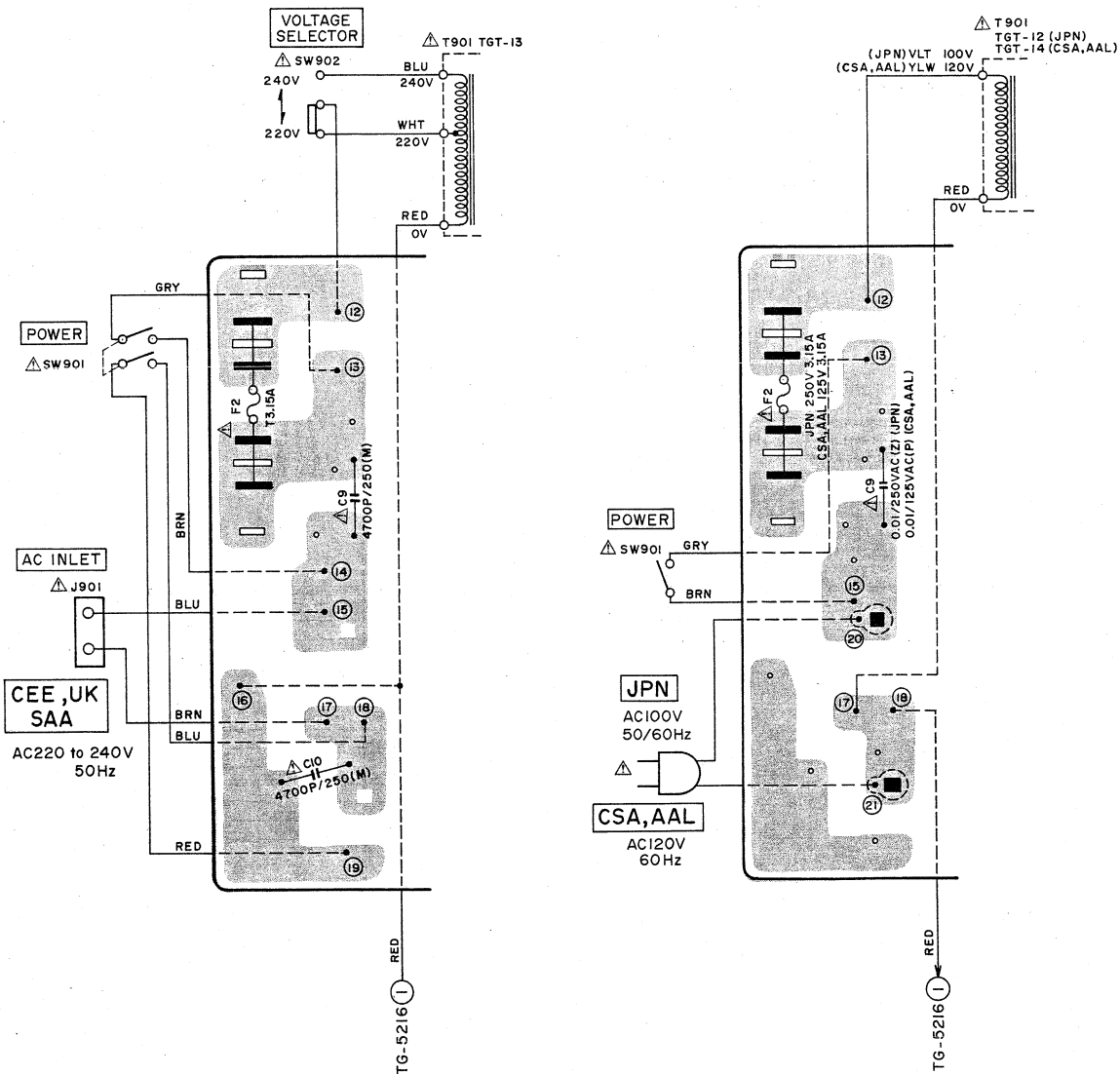

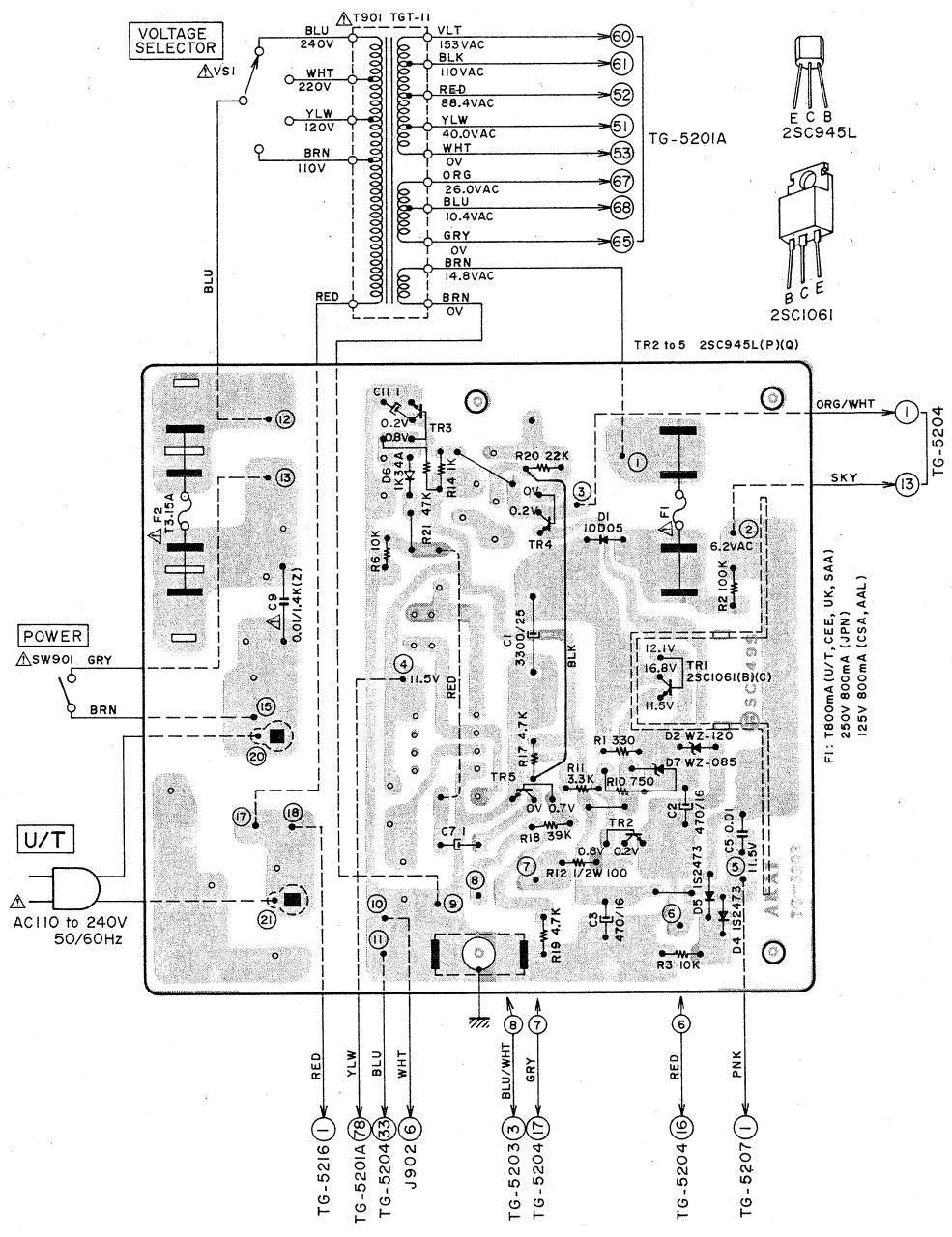

WARNING: Δ INDICATES SAFETY CRITICAL COMPONENTS. FOR CONTINUED SAFETY, REPLACE SAFETY CRITICAL COMPONENTS ONLY WITH MANUFACTURER'S RECOMMENDED PARTS

AVERTISSEMENT: Δ IL INDIQU LES COMPOSANTS CRITIQUES DE SÛRETÉ. POUR MAINTENIR LE DEGRÉ DE SÛRETÉ DE L'APPAREIL, NE REMPLACER LES COMPOSANTS DONT LE FONCTIONNEMENT EST CRITIQUE POUR LA SÛRETÉ QUE PAR DES PIÈCES RECOMMANDÉES PAR LE FABRICANT

MEMO

MEMO

MEMO

SECTION 2

PARTS LIST

TABLE OF CONTENTS

1.	RECOMMENDED SPARE PARTS LIST	50
2.	HEAD BASE BLOCK	54
3.	MOTOR BLOCK (SCM-200)	55
4.	MOTOR BLOCK (24X0-TD)	56
5.	IMPEDANCE ROLLER BLOCK	57
6.	POWER SUPPLY BLOCK	58
7.	AMP ASSEMBLY BLOCK	59
8.	MECHA ASSEMBLY BLOCK	60
9.	PRE AMP P.C BOARD BLOCK	62
10.	POWER & SYS. CON P.C BOARD BLOCK	62
11.	BRAKE CONTROL P.C BOARD BLOCK	63
12.	TIME IND. P.C BOARD BLOCK	63
13.	THYRISTOR P.C BOARD BLOCK	64
14.	FUSE P.C BOARD BLOCK	64
15.	COUNTER P.C BOARD BLOCK	65
16.	FILTER P.C BOARD BLOCK	65
17.	DETECTION P.C BOARD BLOCK	65
18.	FINAL ASSEMBLY BLOCK	66
	INDEX	68

Resistor and Capacitor which is not listed in this parts list, please refer to COMMON LIST FOR SERVICE PARTS.

HOW TO USE THIS PARTS LIST

1. This parts list is compiled by various individual blocks based on assembly process.
2. When ordering parts, please describe parts number, serial number, and model number in detail.
3. How to read List

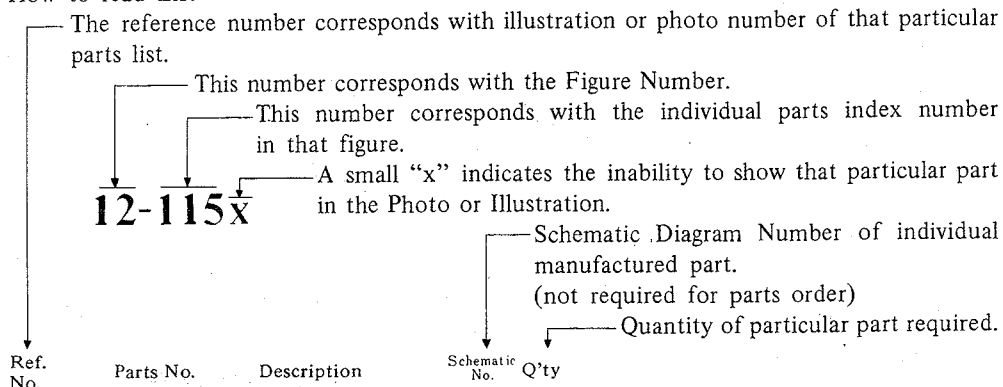

FLYWHEEL BLOCK #13				
12-115x	800425	Flywheel Block Assy. Comp.	RDG #13	1
12-116	244506	Flywheel Only	RD-233	1
12-117x	244754	Felt, Flywheel	RD-275	1
12-118	251324	Main Metal Case	RD-236	1
12-119	253080	Main Metal	RD-237	1

4. The symbol numbers shown on the P.C. Board list can be matched with the Composite Views of Components of the Schematic Diagram or Service Manual.
5. Please utilize separate "Common List for Service Parts" for Resistor Parts orders.
6. The shape of the parts and parts name, etc. can be confirmed by comparing them with the parts shown on the Electrical Parts Table of P.C. Board.
7. Both the kind of part and installation position can be determined by the Parts Number. To determine where a parts number is listed, utilize Parts Index at end of Parts List.
It is necessary first of all to find the Parts Number. This can be accomplished by using the Reference Number listed at right of parts number in the Parts Index. (meaning of ref. no. outlined in Item 3 above).
8. Utilize separate "Price List for Parts" to determine unit price. The most simple method of finding parts Price is to utilize the reference number.

- CAUTION:**
1. When placing an order for parts, be sure to list the parts no. model no., and description. There are instances in which if any of this information is omitted, parts cannot be shipped or the wrong parts will be delivered.
 2. Please be careful not to make a mistake in the parts no. If the parts no. is in error, a part different from the one ordered may be delivered.
 3. Because parts number and parts unit supply in the Preliminary Service Manual (Basic Parts List) may be partially changed, please use this parts list for all future reference.

WARNING: ⚠ INDICATES SAFETY CRITICAL COMPONENTS. FOR CONTINUED SAFETY, REPLACE SAFETY CRITICAL COMPONENTS ONLY WITH MANUFACTURER'S RECOMMENDED PARTS.

AVERTISSEMENT: ⚠ IL INDIQU LES COMPOSANTS CRITIQUES DE SURETE. POUR MAINTENIR LE DEGRE DE SECURITE DE L'APPAREIL NE REMPLACER LES COMPOSANTS DONT LE FONCTIONNEMENT EST CRITIQUE POUR LA SECURITE QUE PAR DES PIECES RECOMMANDEES PAR LE FABRICANT.

AC INLET SYSTEM

This model is equipped with an AC INLET SYSTEM. Please refer to the AC INLET SYSTEM CHART below for the specific type. By the AC INLET SYSTEM, AC (mains) cord can be connected to and disconnected from the model because the model is provided with socket exclusively for AC (mains) cord on its main body.

Please note, however, that certain models are not equipped with this system and has a built-in AC (mains) cord as before.

AC INLET SYSTEM CHART

CLASS I

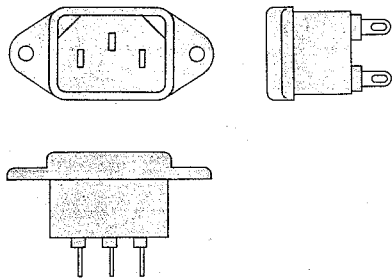

Picture 1
AC INLET
to be
installed
on machines

CLASS II

☐ This mark indicating double insulation will be attached to machine's rear panel

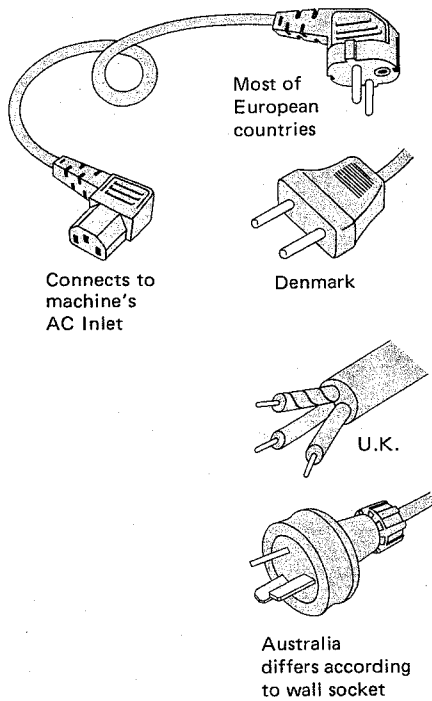
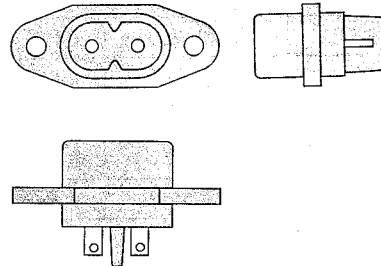

Picture 2
AC (mains)
cord

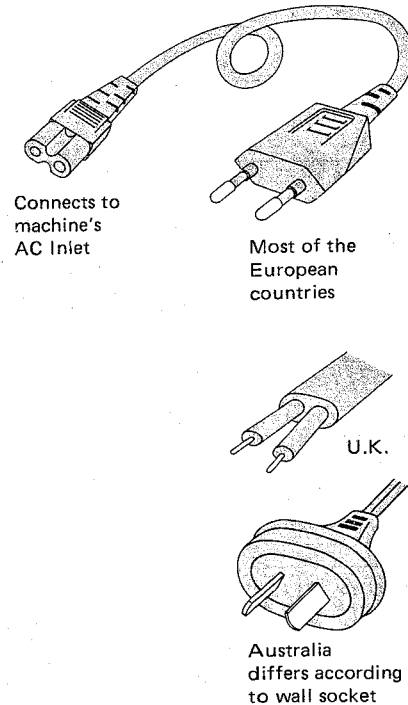

Parts List for AC (mains) Cord Set

	Standard	Description	Type of AC Inlet	Parts No.
Class I	CEE	Cord Set CEE (3 cores)	3P	EW302993
	BEAB	Cord Set BEAB (3 cores)	3P	EW302994
	SAA	Cord Set SAA (3 cores)	3P	EW302996
	U/T	Cord Set U/T (3 cores)	3P	EW302646
Class II	CEE	Cord Set CEE (2 cores)	2P	EW638144
	BEAB	Cord Set BEAB (2 cores)	2P	EW302995
	SAA	Cord Set SAA (2 cores)	2P	EW302991
	U/T	Cord Set U/T (2 cores)	2P	EW302899

1. RECOMMENDED SPARE PARTS LIST

Because, if the parts listed below are on hand, almost any repair can be accomplished, we suggest that you stock these Recommended Spare Parts Items.

Parts No.	Description	Notes
BA324729	Brake Control P.C Board Comp. GX-625	
BA324713	Fuse P.C Board Comp. GX-625 (JPN)	
BA324712	Fuse P.C Board Comp. GX-625 (U/T)	
BA324715	Fuse P.C Board Comp. GX-625 (CEE)	CEE, UK, SAA
BA324714	Fuse P.C Board Comp. GX-625 (CSA)	CSA, AAL
BA324733	Power & Sys. Con P.C Board Comp. GX-625 (JPN)	
BA324732	Power & Sys. Con P.C Board Comp. GX-625 (U/T)	
BA324735	Power & Sys. Con P.C Board Comp. GX-625 (AAL)	
BA324736	Power & Sys. Con P.C Board Comp. GX-625 (CEE)	CEE, UK, SAA
BA324734	Power & Sys. Con P.C Board Comp. GX-625 (CSA)	
BA324706	Pre Amp P.C Board Comp. GX-625 (JPN)	
BA324705	Pre Amp P.C Board Comp. GX-625 (U/T)	U/T, CSA, AAL
BA324707	Pre Amp P.C Board Comp. GX-625 (CEE)	CEE, UK, SAA
BA324722	Thyristor P.C Board Comp. GX-625	
BA320142	Time Ind. P.C Board Comp. GX-625	
BH314075	Head Base Block Comp. GX-620	
BI314142	Impedance Roller Block Comp. GX-620	
BK314428	Operation Key Assy GX-620	
BL314141	Tension Arm Block Comp. GX-620	
BM308310	Motor Block Comp. (SCM-200) GX-635D	
BM587518	Motor Block Comp. 24XO-TD TE	
BR587542	Reel Table Block Comp. TE (Supply)	
BR587553	Reel Table Block Comp. TE (Take-up)	
BT324656	△ Power Trans. TGT-11	U/T
BT324657	△ Power Trans. TGT-12	JPN
BT324658	△ Power Trans. TGT-13	CEE, SAA, UK
BT324659	△ Power Trans. TGT-14	CSA, AAL
EC316183	Elect./C. (Vert.) 1000 μ F 16WV	
EC316182	Elect./C. (Vert.) 2200 μ F 16WV	
EC316230	Elect./C. (Vert.) 2200 μ F 35WV	
EC321628	Elect./C. (Vert.) 3300 μ F 25WV	
EC322419	Elect./C. (Vert.) 3300 μ F 25WV	
EC558202	Trimmer/C. TM-80A 80PF	
ED308953	Germanium Diode 1K34A-LH	
ED308952	Germanium Diode 1K34A-LR	
ED310585	LED GL-9PG2	
ED310584	LED GL-9PR2	JPN
ED324676	LED, 4 Figures 7 Segments SL-1476-04W	
ED308941	Silicon Diode SVB10-200	
ED306109	Silicon Diode W03B	

Parts No.	Description	Notes
ED560913	Silicon Diode 1S2473 VE	
ED316143	Silicon Diode 1S2473-HS	
ED318292	Silicon Diode 1S2473T-77	
ED494583	Silicon Diode 10D05	
ED224550	Silicon Diode 10D4	
ED324669	Silicon Diode 10D4-FA-2	
ED326168	Silicon Stack 1D4B1	
ED324667	Thyristor 2P1M	
ED324013	Zener Diode HZ20-2	
ED309069	Zener Diode HZ6B-2	
ED281621	Zener Diode WZ-071	
ED491130	Zener Diode WZ-085	
ED510772	Zener Diode WZ-120	
EF309392	△ Fuse 1.25A 125V	CSA, AAL
EF306949	△ Fuse 1.25A 250V	U/T, JPN
EF308847	△ Fuse 1.6A 125V	CSA, AAL
EF311839	△ Fuse 1.6A 250V	U/T, JPN
EF323080	△ Fuse 3.15A 125V	CSA, AAL
EF326639	△ Fuse 3.15A 250V	JPN
EF309391	△ Fuse 800mA 125V	CSA, AAL
EF309388	△ Fuse 800mA 250V	U/T, JPN
EF602550	△ Fuse (Semko T) 1.25AT 250V	CEE, UK, SAA
EF623103	△ Fuse (Semko T) 1AT	CEE, UK, SAA
EF691007	△ Fuse (Semko T) 3.15AT	U/T, CEE, SAA, UK
EF593706	△ Fuse (Semko T) 500MAT	CEE, UK, SAA
EF601942	△ Fuse (Semko T) 630MAT	CEE, UK, SAA
EF258344	△ Fuse (Semko T) 800MAT	U/T, CEE, SAA, UK
EI310183	IC MC14001 BCP	
EI324681	IC HD14027BP	
EI306141	IC LA4170	
EI316170	IC LB1270	
EI324675	IC LM8523	
EI304165	IC MB400M	
EI304166	IC MB418	
EI696363	IC MC14049BCP	
EI324686	IC HD14071BP	
EI324690	IC HD14075BP	
EI324789	IC MC14078BCP	
EI324694	IC HD14081BP	
EI324699	IC HD14082BP	

Parts No.	Description	Notes
EI308936	IC M54410P	
EI324682	IC TC4027BP	
EI324668	Triac AC03BGM-L	
EJ301513	△ Inlet 2P	CEE, UK, SAA
EJ262732	△ Socket (Volt. Selector)	U/T
EJ249467	△ Voltage Selector	U/T
EJ316156	Head Phone Jack HLJ0315-01-020	
EJ306289	Mic Jack HLJ0278-01-010	
EJ306985	Pin Jack 4P	
EJ308986	Pin Jack 4P	JPN
EL316167	Lamp 24V 250mA	
EL324540	Lamp (Fuse Type) 12V 55mA	
EM316135	VU Meter KL-292B-1	
EM316689	VU Meter KL-292B-2	BL
EO383365	Osc. Coil OT-204	
EP316121	Plunger	
EP309056	Plunger 0730FLT	
EP315918	Plunger 1240PLTI	
EP308949	Relay BR211	
EP308973	Relay LAB2NS DC 24V	
EP324462	Relay MY4-02-US DC 12V	
EP324672	Relay 321D012	
ER308955	Cement/R. 20W 36 ohms (K)	
ER318415	Cement/R. 20W 360 ohms (K)	
ER320528	Fuse/R. F 1/4W 22 ohms (G)	
ER326169	Fuse/R. F 1/4W 22 ohms (G)	
ER308898	Fuse/R. 1/4W 100 ohms (J)	
ER561216	Fuse/R. 1/4W 100 ohms (K) 200mA	
ER326167	Fuse/R. 20W 39 ohms (K)	
ES309059	△ Push SW. JP-27	U/T, JPN, CSA, AAL
ES310333	△ Push SW. (S) (D) JP-28	CEE, UK, SAA
ES306430	△ Slide SW. J-S4013#01	CEE, UK, SAA
ES315747	Lever SW. 42388	
ES562465	Micro SW. K-1	
ES316169	Push SW. SUF-12	
ES316159	Push SW. SUF-54	
ES316117	Rotary SW. SRN-1013N	
ES323367	Sensi Touch SW. KEC 10001	
ES324677	Sensi Touch SW. KEC11902	
ES309094	Slide SW. SL13-6-6-2-2-B	U/T, JPN

Parts No.	Description	Notes
ET284264	FET 2SK68 (L) 2	
ET313717	FET 2SK68A (M)	
ET324539	Photo Transistor PT-410	
ET554657	Transistor 2SA733 (P) (Q)	
ET375603	Transistor 2SC1061 (B) (C)	
ET302502	Transistor 2SC2001 (K)	
ET304181	Transistor 2SC2002 (K)	
ET310832	Transistor 2SC2130 (G)	
ET308937	Transistor 2SC2130 (G) (H)	
ET308947	Transistor 2SC2336B (Q) (R)	
ET352146	Transistor 2SC458LG (D)	
ET316171	Transistor 2SC536K-NP (E) (F)	
ET429748	Transistor 2SC711 (H)	
ET638504	Transistor 2SC945L (P)	
ET639437	Transistor 2SC945L (Q) (P)	
ET666404	Transistor 2SD571 (K) (L)	
ET307349	Transistor 2SD794 (P) (Q)	
EV315751	Double-Axial 2-Throw/Vol. DM20R 50kA×2	
EV315753	Semi-Fixed/Vol. D8 Axial 20kB	
EV315540	Semi-Fixed/Vol. D8 Axial 5kB	
EV315541	Semi-Fixed/Vol. D8 Axial 50kB	
EV302718	Semi-Fixed/Vol. V18K3-6 (4US) 50kB	
EV309071	Semi-Fixed/Vol. V18K3-6 (4US) 20kB	
EV464207	Semi-Fixed/Vol. V8K4-1 5kB	
EV313538	Single-Axial 2-Throw/Vol. GM80R 10kB×2	
EV315928	Vol. VM10E 1kB	
EZ324787	Photo Coupler TLP504	
HE311139	Erase Head E4-201	
HP318522	PB Head P4-251	
HR308148	REC Head R4-241	
MB324611	Detection Belt	
MP582164	Pinch Roller D=42	
MT314987	Brake Band	

2. HEAD BASE BLOCK

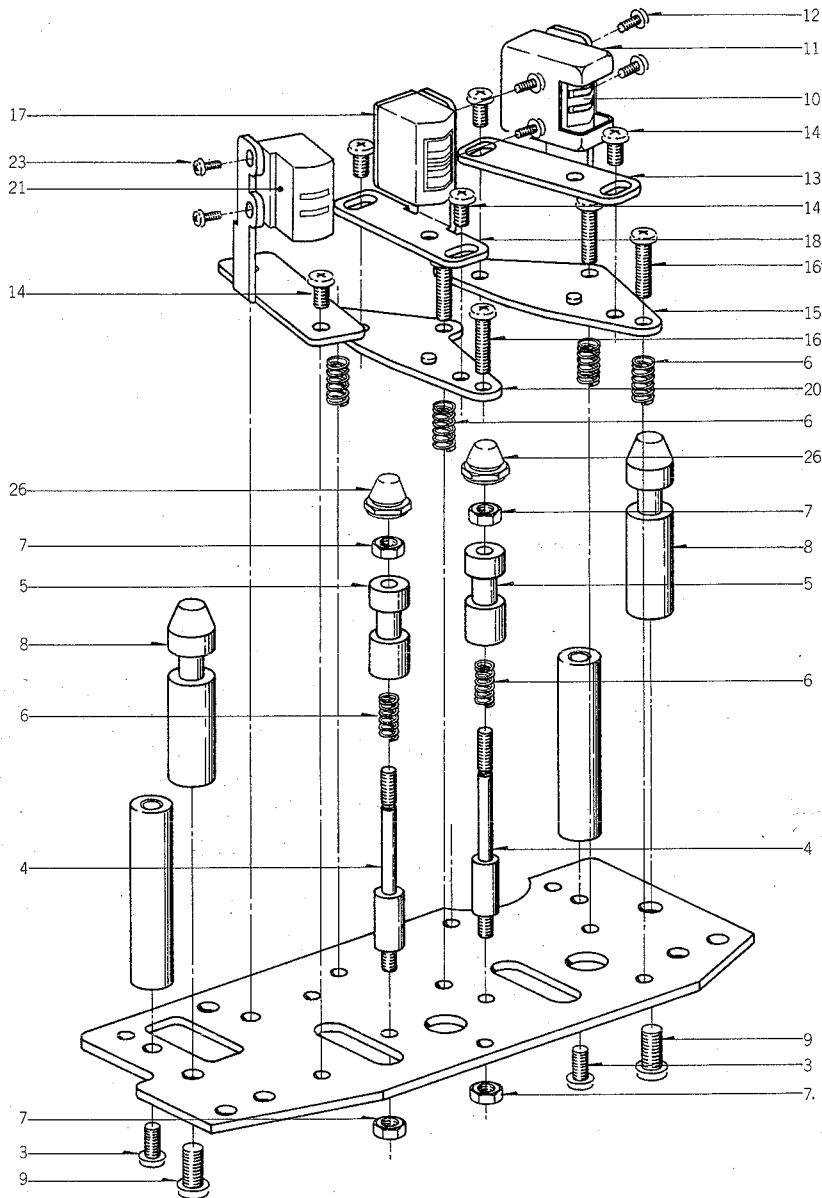

HEAD BASE BLOCK

Ref. No.	Parts No.	Description	Schematic No.	Ref. No.	Parts No.	Description	Schematic No.
2-1x	BH314075	Head Base Block Comp. GX-620		2-14	ZS304806	Screw, Bind 3x5 (Black)	
2-2x	ZS417150	Screw, Pan 4x6		2-15	HZ316006	P Head Base	TG-0005
2-3	ZS379350	Screw, Pan 3x6		2-16	ZS608501	Screw, Pan 3x12 (Black)	
2-4	MH316004	Tape Guide Prop	TG-0003	2-17	HR308148	REC Head R4-241	
2-5	HZ532710	Tape Guide (B)	TW-0006	2-18	HA316009	RH Angle	TG-0008
2-6	ZG466312	Angle Adjust Spring (E)	BS-0018	2-19	ZS539741	Screw, Pan 2x4 (Black)	
2-7	ZW265522	Nut, #2 M3		2-20	HZ316008	R Head Base	TG-0007
2-8	HZ316005	Tape Guide	TG-0004	2-21	HE311139	Erase Head E4-201	
2-9	ZS413201	Screw, Pan 4x8		2-22	HA321735	EH Angle	TG-0026
2-10	HP318522	PB Head P4-251		2-23	ZS304464	Screw, Pan 2x3 (Black)	
2-11	HZ301366	Head Shield	NE-0211	2-24x	EJ316129	4P Micro Connector Assy	26-6-332
2-12	ZS608411	Screw, Pan 2x5 (Black)		2-25x	EJ316130	7P Micro Connector Assy	26-6-333
2-13	HA316007	PH Angle	TG-0006	2-26	ZW316011	Decoration Nut	TG-0010

When ordering parts, please quote Parts Number, Description and Model Number.

3. MOTOR BLOCK (SCM-200)

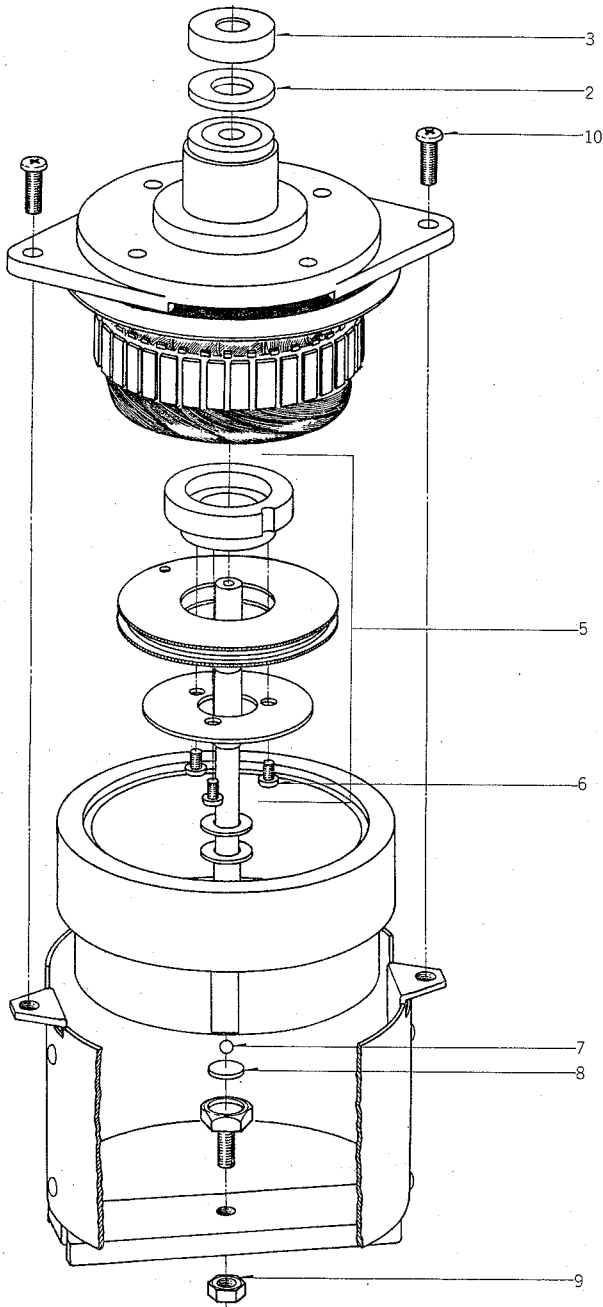

MOTOR BLOCK (SCM-200)

Ref. No.	Parts No.	Description	Schematic No.
3-1x	BM308310	Motor Block Comp. (SCM-200) GX-635D	
3-2	ZW597622	Felt Washer	KJ-7022
3-3	SK597633	Cap	KJ-7023
3-4x	ZS608308	Screw, Pan 3x18 w/Washer	
3-5	BZ308315	Detection Gear Assy GX-635D	
3-6	ZS201508	Screw, Pan 2x4	
3-7	MV368886	Steel Ball D3	
3-8	MZ597690	Ball Holder	KJ-7029
3-9	ZW413278	Nut, #1 M5	
3-10	ZS413201	Screw, Pan 4x8	

When ordering parts, please quote Parts Number, Description and Model Number.

4. MOTOR BLOCK (24XO-TD)

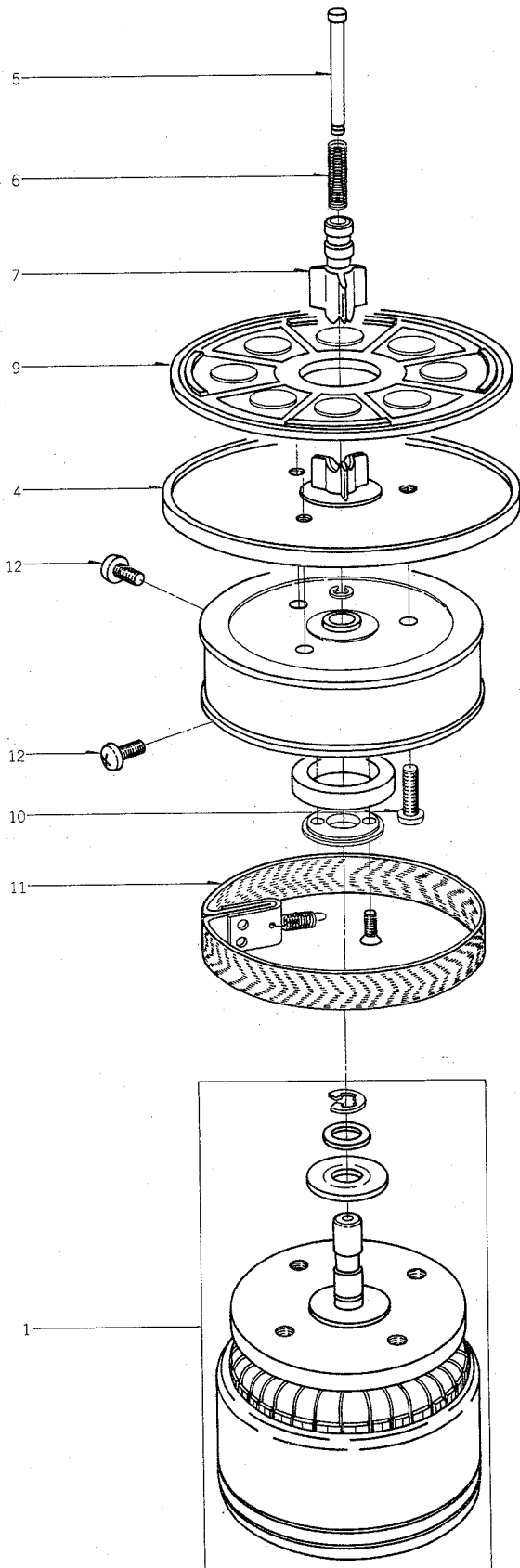

MOTOR BLOCK (24XO-TD)

Ref. No.	Parts No.	Description	Schematic No.
4-1	BM587518	Motor Block Comp. 24XO-TD TE	
4-2x	BR587542	Reel Table Block Comp. TE (Supply)	
4-3x	BR587553	Reel Table Block Comp. TE (Take-up)	
4-4	MT534666	Reel Table	TW-2031
4-5	MS342000	Reel Shaft	3R-108
4-6	ZG540617	Clamper Spring	TW-2096
4-7	MT534677	Reel Clamper	TW-2032
4-8	ZW270088	'E' Ring 1.9M	6-1-9
4-9	MT534688	Reel Table Rubber	TW-2033
4-10	ZS419670	Screw, Pan 3x12	
4-11	MT436860	Brake Cloth Comp.	MR-269
4-12	ZS424056	Screw, Pan 4x10	

When ordering parts, please quote Parts Number, Description and Model Number.

5. IMPEDANCE ROLLER BLOCK

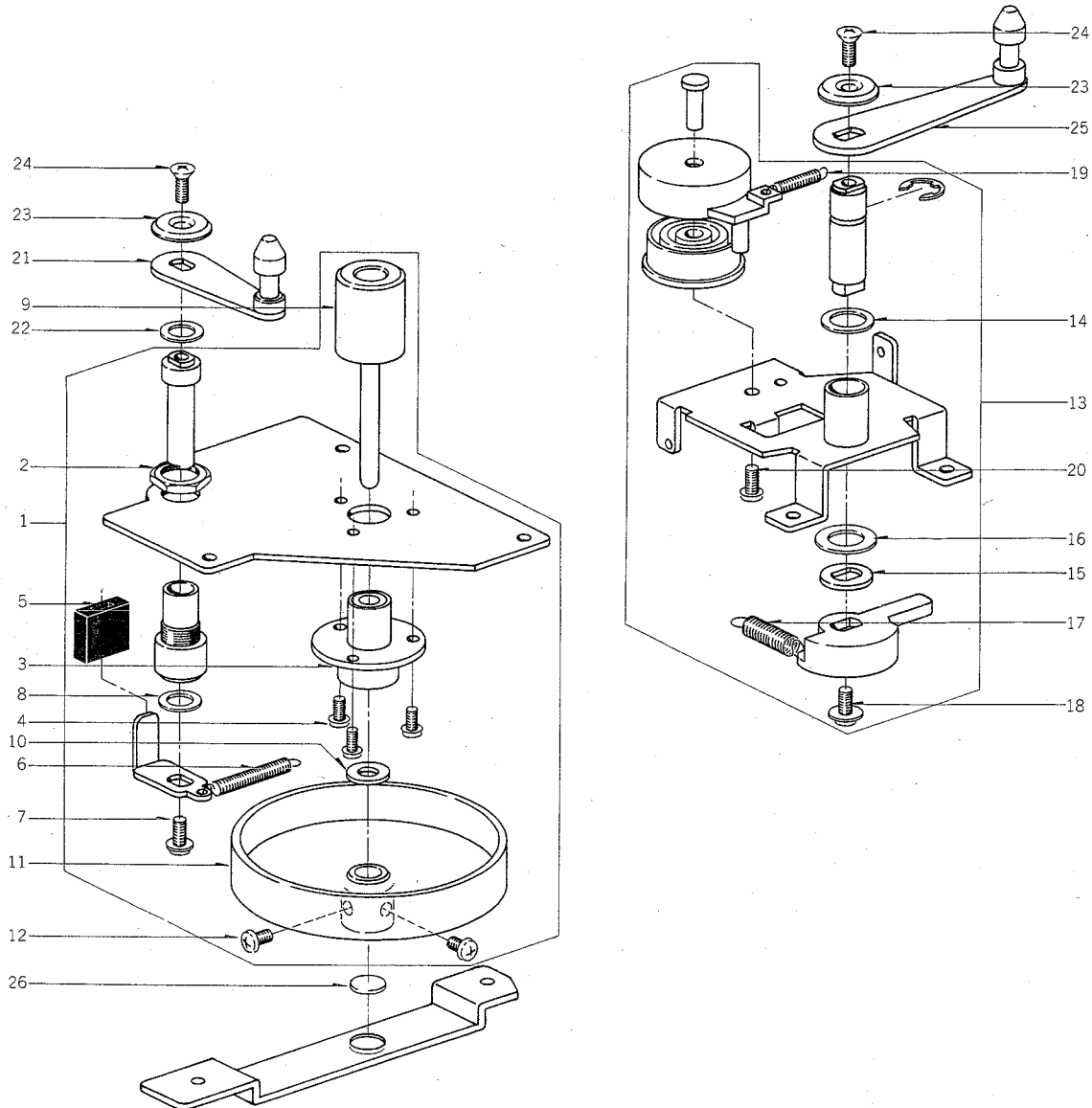

IMPEDANCE ROLLER BLOCK

Ref. No.	Parts No.	Description	Schematic No.	Ref. No.	Parts No.	Description	Schematic No.
5-1	BI314142	Impedance Roller Block Comp. GX-620		5-14	ZW260256	Washer (PBP) D8.1×13×0.1t	
5-2	ZW270191	E Jack Nut	7-1-56	5-15	ZW580498	Tension Arm Washer	TD-2042
5-3	BZ283432	Main Case Part	MY-2074	5-16	ZW575763	Washer (SPC) D8.1×13×0.5t	
5-4	ZS499331	Screw, Pan 2.3×5		5-17	ZG659608	Tension Spring	TE-2034
5-5	MB665561	TE Stopper Rubber	TE-2039	5-18	ZS608321	Screw, Pan 3×6 W=8	
5-6	ZG232121	Tension Lever Spring	MH-143	5-19	ZG312947	Coil Spring T1-3.2/0.29-18.0	
5-7	ZS558101	Screw, Pan 3×6 w/Washer		5-20	ZS379350	Screw, Pan 3×6	
5-8	ZW260010	Washer (PBP) D6.1×10×0.1t		5-21	ML692504	Tension Arm Part TE	TE-2003
5-9	MS301415	Z Roller Part	MY-2077	5-22	ZW560226	Washer (PBP) D6.1×10×0.2t	
5-10	ZW301378	Washer D3×10×0.5t Teflon		5-23	ZW302052	Decorative Washer	NE-1212
5-11	MI305146	Flywheel Part	MY-2078	5-24	ZS200384	Screw, Countersunk 3×6	
5-12	ZS422076	Screw, Pan 3×5		5-25	ML694506	Tension Arm Part TD	TD-2039
5-13	BL314141	Tension Arm Block Comp. GX-620		5-26	ZW462205	Washer (Nylon) D7.9×1t (without Hole)	

When ordering parts, please quote Parts Number, Description and Model Number.

6. POWER SUPPLY BLOCK

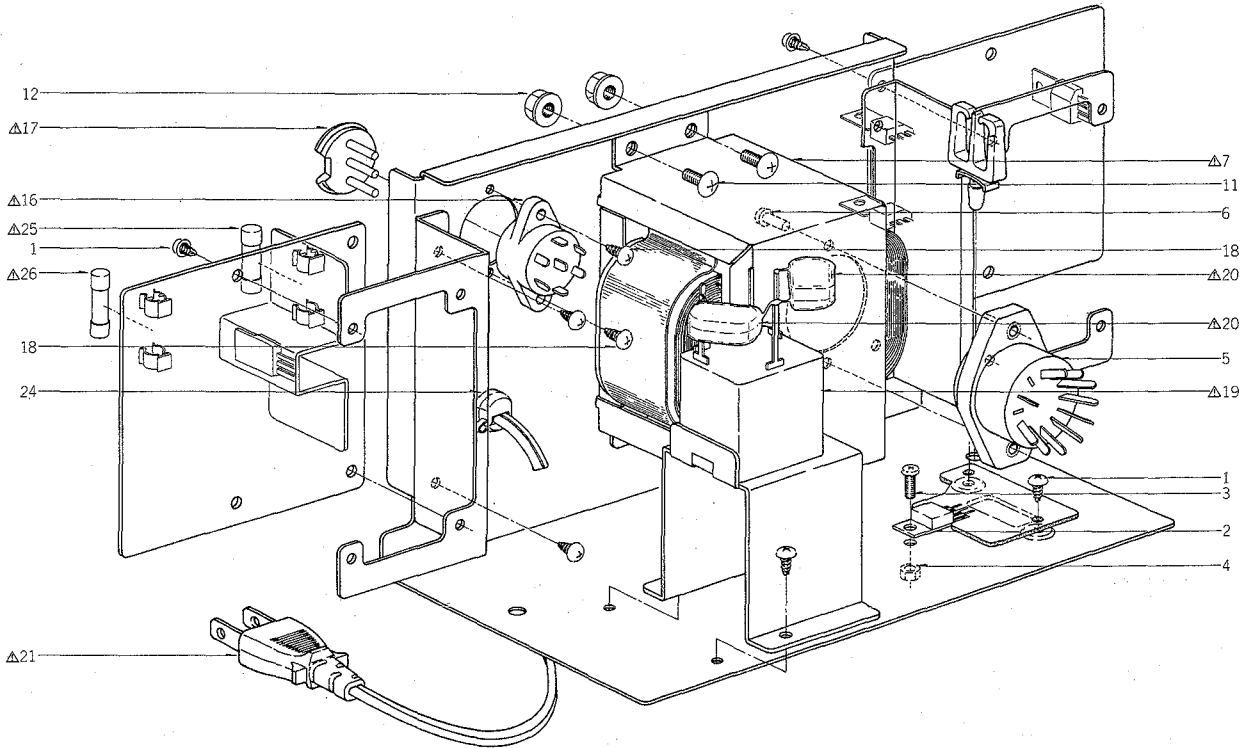

POWER SUPPLY BLOCK

Ref. No.	Parts No.	Description	Schematic No.	Ref. No.	Parts No.	Description	Schematic No.
6-1	ZS325495	Tapping Screw, #2 BR 3x6		6-20	EC325644	Δ Metallized Mylar/C. 0.47μF(K) 250WV	24-16-23
6-2	ET308947	Transistor 2SC2336B(Q)(R)	45-1-333	6-21	EW306428	Δ AC Cord (U/T)	26-3-64
6-3	ZS421806	Screw, Pan 3x8		6-22x	EW306427	Δ AC Cord (JPN)	26-3-63
6-4	ZW273756	Nut, #1 M3		6-23x	EW305691	Δ AC Cord CUL (CSA)	26-3-65
6-5	EJ307274	9P Remo. Con Socket	31-1-223	6-24	EZ631945	Strain Relief SR-4N-4 (U/T, JPN, CSA)	2-7-49
6-6	ZS421740	Screw, Pan 3x8 (Black)		6-25	EF258344	Δ Fuse (Semko T) 800MAT (U/T, CEE, SAA, UK)	39-1-53
6-7	BT324656	Δ Power Trans. TGT-11 (U/T)	38-4-814	6-26	EF691007	Δ Fuse (Semko T) 3.15AT (U/T, CEE, SAA, UK)	39-1-53
6-8x	BT324657	Δ Power Trans. TGT-12 (JPN)	38-4-815	6-27x	EF309388	Δ Fuse 800mA 250V. (JPN)	39-1-64
6-9x	BT324659	Δ Power Trans. TGT-14 (CSA, AAL)	38-4-817	6-28x	EF326639	Δ Fuse 3.15A 250V (JPN)	39-1-64
6-10x	BT324658	Δ Power Trans. TGT-13 (CEE, SAA, UK)	38-4-816	6-29x	EF309391	Δ Fuse 800mA 125V (CSA, AAL)	39-1-65
6-11	ZS435273	Screw, Bind 4x10		6-30x	EF323080	Δ Fuse 3.15A 125V(CSA, AAL)	39-1-65
6-12	ZW413267	Flange Nut M4		6-31x	EW315767	Δ AC Cord Set CEE 2 Cores (CEE)	26-3-72
6-13x	EJ301513	Δ Inlet 2P (CEE, UK, SAA)	31-1-200	6-32x	EW322400	Δ AC Cord Set BASEC 2 Cores (UK)	26-3-73
6-14x	ES306430	Δ Slide SW. J-S4013#01 (CEE, UK, SAA)	25-3-142	6-33x	EW322401	Δ AC Cord Set SAA 2 Cores (SAA)	26-3-77
6-15x	ZS447840	Tapping Screw, #2 BR 3x8 (CEE, UK, SAA)					
6-16	EJ262732	Δ Socket (Volt. Selector) (U/T)	31-1-190				
6-17	EJ249467	Δ Voltage Selector (U/T)	42-1-109				
6-18	ZS447840	Tapping Screw, #2 BR 3x8(U/T)					
6-19	EC316065	Δ Metallized Polyester/C. 4+4μF(M) 250VAC	24-16-18				

When ordering parts, please quote Parts Number, Description and Model Number.

7. AMP ASSEMBLY BLOCK

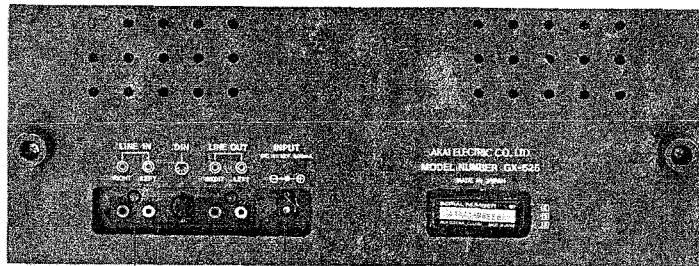
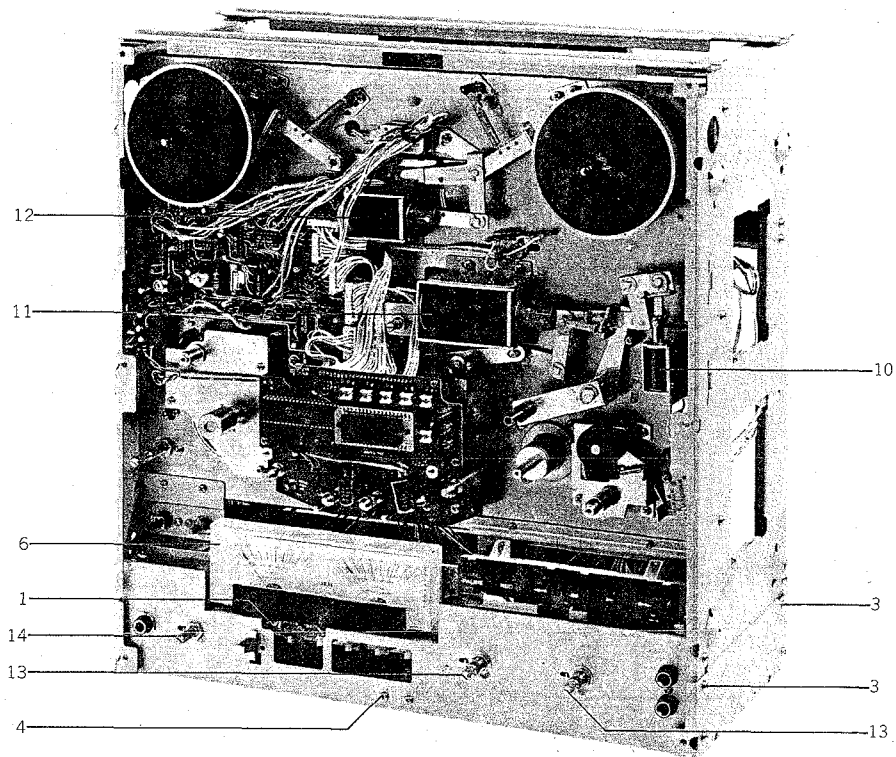

AMP ASSEMBLY BLOCK

Ref. No.	Parts No.	Description	Schematic No.	Ref. No.	Parts No.	Description	Schematic No.
7-1	ED310585	LED GL-9PG2	45-15-22	7-9	ZS302699	Tapping Screw, #2 Pan 2.3x6	
7-2x	ED310584	LED GL-9PR2 (JPN)	45-15-21	7-10	EP309056	Plunger 0730FLT	44-1-105
7-3	ZS325495	Tapping Screw, #2 BR 3x6		7-11	EP316121	Plunger	44-1-119
7-4	ZS422076	Screw, Pan 3x5		7-12	EP315918	Plunger 1240PLTI	44-1-120
7-5	ZW263946	Nylon Rivet 4x5	2-7-57	7-13	EV315751	Double-Axial 2-Throw/Vol.	
7-6	EM316135	VU Meter KL-292B-1	46-1-229			DM20R 50kA x2	36-18-16
7-7x	EM316689	VU Meter KL-292B-2 (BL)	46-1-232	7-14	EV313538	Single-Axial 2-Throw/Vol.	
7-8	EJ310203	△ Connector HEC-0630-01-020	42-1-135			GM80R 10kB x2	36-22-43

When ordering parts, please quote Parts Number, Description and Model Number.

8. MECHA ASSEMBLY BLOCK

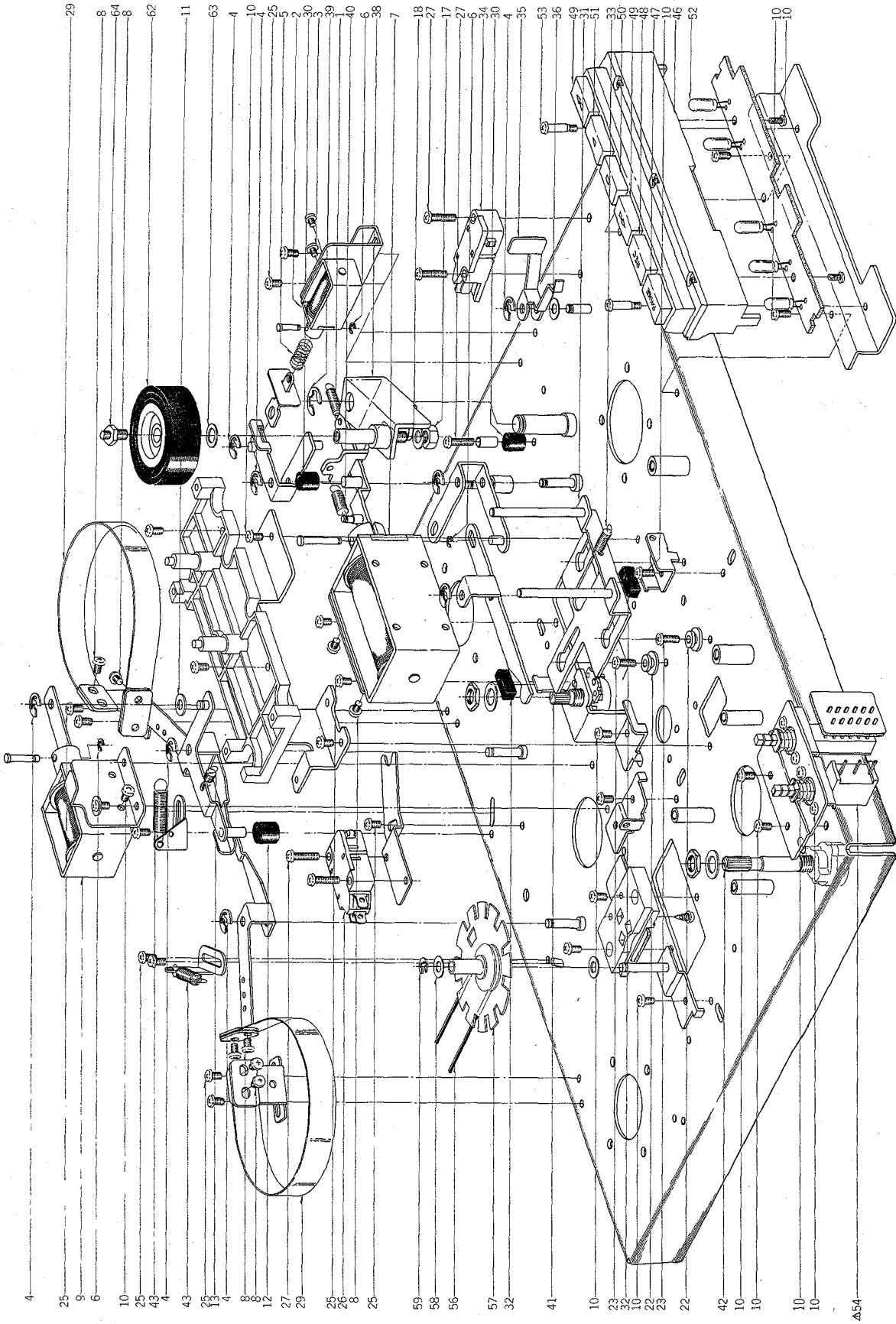

MECHA ASSEMBLY BLOCK

Ref. No.	Parts No.	Description	Schematic No.
8-1	ZG321132	P Lever Spring	TG-2024
8-2	EP309056	Plunger 0730FLT	44-1-105
8-3	ZS592378	Screw, Pan 2.6x3	
8-4	ZW290283	'U' Ring 2.85M	6-1-1
8-5	ZG308734	Joint Spring	TH-2031
8-6	ZW270088	'E' Ring 1.9M	6-1-9
8-7	EP316121	Plunger	44-1-119
8-8	ZS417216	Screw, Pan 3x4	
8-9	EP315918	Plunger 1240PLTI	44-1-120
8-10	ZS422076	Screw, Pan 3x5	
8-11	ZW420682	Washer (Nylon) D4.2x9x0.5t	
8-12	MZ397181	Lever Cushion	KD-1069
8-13	ZG580522	Clutch Lever Spring	TD-2045
8-14x	ZS413201	Screw, Pan 4x8	
8-15x	ZW273756	Nut, #1 M3	
8-16x	ZW413188	Nut, #1 M4	
8-17	ZW413278	Nut, #1 M5	
8-18	ZW274026	Spring Washer, M5	
8-19x	ZW462205	Washer (Nylon) D7.9x11 (without Hole)	
8-20x	ZS380046	Screw, Pan 3x10	
8-21x	ZS325495	Tapping Screw, #2 BR 3x6	
8-22	MH316022	Collar	TG-1009
8-23	ZS421806	Screw, Pan 3x8	
8-24x	ZS417150	Screw, Pan 4x6	
8-25	ZS323728	Screw, Bind 3x5	
8-26	ES573478	Micro SW. K-3	25-1-31
8-27	ZS419670	Screw, Pan 3x12	
8-28x	ZS483502	Screw, Pan 3x13 (UK)	
8-29	MT314987	Brake Band	MR-213
8-30	MB606712	Stopper Rubber KJ	KJ-2060
8-31	ML314426	Shifter Plate Part GX-620	TG-1010
8-32	MB668801	Stopper Rubber TE (B)	TE-2039
8-33	ZG312998	Coil Spring T1-4.0/0.4-18.0	
8-34	ES562465	Micro SW. K-1	25-1-26
8-35	MZ580680	Actuator	TD-2068
8-36	ZW316136	Washer D4.1x9x0.5t Nylon	
8-37x	ZS432674	Screw, Pan 3x3	
8-38	BL314071	P Arm Assy GX-620	TG-2028
8-39	ZW270156	'E' Ring 6M	6-1-9
8-40	ZG316040	P Spring	TG-2008
8-41	EV315928	Vol. VM10E 1kB	36-6-38
8-42	ES316117	Rotary SW. SRN-1013N	25-6-172
8-43	ZG672478	Brake Spring	TE-1017
8-44x	ZS201802	Screw, Pan 4x8 w/Lug	
8-45x	ZS413245	Screw, Pan 4x15	
8-46	BK314428	Operation Key Assy GX-620	25-5-324
8-47	SB316162	Operation Button (PAUSE)	25-5-324
8-48	SB316163	Operation Button (REC)	25-5-324
8-49	SB316164	Operation Button (FF, REW)	25-5-324
8-50	SB316165	Operation Button (STOP)	25-5-324
8-51	SB316166	Operation Button (FWD)	25-5-324
8-52	EL316167	Lamp 24V 250mA	25-5-324
8-53	ZS316119	Graduated Screw	TG-1020
8-54	ES309059	△ Push SW. JP-27 (U/T, JPN, CSA, AAL)	25-5-285
8-55x	ES310333	△ Push SW. (S)(D) (CEE, UK, SAA)	25-5-308
8-56	MB324611	Detection Belt	TG-1202
8-57	MR324582	Detection Pulley Outsert Part	TG-2202
8-58	ZW676045	Washer (Teflon) D4.2x9x0.5t	
8-59	ZW270101	'E' Ring 3M	6-1-9
8-60x	ZS310343	Special Tapping Screw, Pan 3x6	7-1-70
8-61x	ZS498273	Tapping Screw #2, BR 3x8 W=8	
8-62	MP582164	Pinch Roller D=42	TD-1034
8-63	ZW376391	Washer (Polyslider) D6.1x10x0.13t	
8-64	ZS527681	Pinch Roller Set Screw	ND-6019

When ordering parts, please quote Parts Number, Description and Model Number.

9. PRE AMP P.C BOARD BLOCK

Symbol No.	Parts No.	Description	Schematic No.
9-1	BA324705	Pre Amp P.C Board Comp. GX-625 (U/T) (U/T, CSA, AAL)	TG-5001A
9-2	BA324706	Pre Amp P.C Board Comp. GX-625 (JPN)	TG-5001A
9-3	BA324707	Pre Amp P.C Board Comp. GX-625 (CEE) (CEE, UK, SAA)	TG-5001A
9-IC1	EI306141	IC LA4170	45-8-305
9-TR1to3	ET352146	Transistor 2SC458LG(D)	45-1-29
9-TR4,5	ET639437	Transistor 2SC945L(Q)(P)	45-1-85
9-TR6,7	ET304181	Transistor 2SC2002(K)	45-1-281
9-TR8to10	ET352146	Transistor 2SC458LG(D)	45-1-29
9-TR11,12	ET639437	Transistor 2SC945L(Q)(P)	45-1-85
9-TR13	ET313717	FET 2SK68A(M)	45-12-9
9-TR14	ET639437	Transistor 2SC945L(Q)(P)	45-1-85
9-TR15	ET307349	Transistor 2SD794(P)(Q)	45-1-334
9-TR16to20	ET639437	Transistor 2SC945L(Q)(P)	45-1-85
9-D1	ED318292	Silicon Diode 1S2473T-77	45-3-59
9-D2	ED308953	Germanium Diode 1K34A-LH	45-3-46
9-D3	ED318292	Silicon Diode 1S2473T-77	45-3-59
9-D4,5	ED308953	Germanium Diode 1K34A-LH	45-3-46
9-D6,7	ED560913	Silicon Diode 1S2473 VE	45-3-23
9-D8to10	ED318292	Silicon Diode 1S2473T-77	45-3-59
9-D11	ED560913	Silicon Diode 1S2473 VE	45-3-23
9-D12	ED308953	Germanium Diode 1K34A-LH	45-3-46
9-VR1,2	EV315751	Double-Axial 2-Throw/Vol. DM20R 50kA x2	36-18-16
9-VR3	EV315753	Semi-Fixed/Vol. D8 Axial 20kB	36-10-282
9-VR4	EV315541	Semi-Fixed/Vol. D8 Axial 50kB	36-10-282
9-VR5	EV313538	Single-Axial 2-Throw/Vol. GM80R 10kB x2	36-22-43
9-VR6	EV315540	Semi-Fixed/Vol. D8 Axial 5kB	36-10-282
9-J1	EJ306289	Mic Jack HLJ0278-01-010	31-2-91
9-J2	EJ316156	Head Phone Jack HLJ0315-01-020	31-2-106
9-J3	EJ306985	Pin Jack 4P	31-5-142
9-J3	EJ308986	Pin Jack 4P (JPN)	31-5-145
9-SW1to5	ES316159	Push SW. SUF-54	25-5-323
9-SW6	ES315747	Lever SW. 42388	25-12-61
9-RL1	EP308973	Relay LAB2NS DC24V	47-2-30
9-T1	EO383365	Osc. Coil OT-204	23-4-20
9-L1	EO301467	Ferri Inductor RX-9P 3.3MH (J)	23-1-275
9-L2	EO316142	Ferri Inductor RC875 220µH (J)	23-1-335
9-VL1	EO346230	Inductor RX 22MH	23-1-15
9-VL2	EO316141	Inductor 55T131 1.5MH	23-1-315
9-VL3	EO346230	Inductor RX 22MH	23-1-15
9-FR1	ER308898	Fuse/R. 1/4W 100 ohms(J)	35-14-23
9-VC1	EC558202	Trimmer/C. TM-80A 80PF	24-2-26
9-R40,41	ER322787	Carbon/R. F 1/4WS 10 ohms (J)	35-11-30
9-R76	ER316144	Metal Oxide Film/R. 2W 390 ohms (J)	35-11-19
9-C28	EC306420	Styrol/C. 750PF(J) 50WV	24-11-14
9-C29	EC316149	Styrol/C. 1800PF(J) 500WV	24-11-16
9-C44	EC316150	Styrol/C. 820PF(J) 50WV	24-11-14
9-C70	EC321173	Styrol/C. 180PF(J) 50WV	24-11-14

10. POWER & SYS. CON P.C BOARD BLOCK

Symbol No.	Parts No.	Description	Schematic No.
10-1	BA324732	Power & Sys. Con P.C Board Comp. GX-625 (U/T)	TG-5201A
10-2	BA324733	Power & Sys. Con P.C Board Comp. GX-625 (JPN)	TG-5201A
10-3	BA324734	Power & Sys. Con P.C Board Comp. GX-625 (CSA)	TG-5201A
10-4	BA324735	Power & Sys. Con P.C Board Comp. GX-625 (AAL)	TG-5201A
10-5	BA324736	Power & Sys. Con. P.C Board Comp. GX-625 (CEE) (CEE, UK, SAA)	TG-5201A
10-IC1	EI308936	IC M54410P	45-8-304
10-IC2,3	EI316170	IC LB1270	45-8-369
10-IC4,5	EI304165	IC MB400M	45-8-252
10-IC6	EI304166	IC MB418	45-8-253
10-TR1	ET307349	Transistor 2SD794(P)(Q)	45-1-334
10-TR2	ET375603	Transistor 2SC1061(B)(C)	45-1-96
10-TR3	ET316171	Transistor 2SC536K-NP(E)(F)	45-1-362
10-TR4	ET375603	Transistor 2SC1061(B)(C)	45-1-96
10-TR5to9	ET316171	Transistor 2SC536K-NP(E)(F)	45-1-362
10-TR10to12	ET554657	Transistor 2SA733(P)(Q)	45-1-124
10-TR14	ET554657	Transistor 2SA733(P)(Q)	45-1-124
10-TR15to22	ET316171	Transistor 2SC536K-NP(E)(F)	45-1-362
10-TR23	ET308937	Transistor 2SC2130(G)(H)	45-1-317
10-TR24	ET310832	Transistor 2SC2130(G)	45-1-317
10-TR25	ET308937	Transistor 2SC2130(G)(H)	45-1-317
10-TR26	ET666404	Transistor 2SD571(K)(L)	45-1-218
10-TR27	ET302502	Transistor 2SC2001(K)	45-1-272
10-D1,2	ED494583	Silicon Diode 10D05	45-2-42
10-D3	ED326168	Silicon Stack 1D4B1	45-2-110
10-D4	ED308941	Silicon Diode SVB10-200	45-2-82
10-D5	ED309069	Zener Diode HZ6B-2	45-6-80
10-D6	ED324013	Zener Diode HZ20-2	45-6-80
10-D7,8	ED510772	Zener Diode WZ-120	45-6-67
10-D9to19	ED560913	Silicon Diode 1S2473 VE	45-3-23
10-D20to23	ED308952	Germanium Diode 1K34A-LR	45-3-47
10-D24to28	ED560913	Silicon Diode 1S2473 VE	45-3-23
10-D29	ED316143	Silicon Diode 1S2473-HS	45-3-53
10-D30	ED560913	Silicon Diode 1S2473 VE	45-3-23
10-D31	ED308952	Germanium Diode 1K34A-LR	45-3-47
10-D32	ED316143	Silicon Diode 1S2473-HS	45-3-53
10-D33	ED560913	Silicon Diode 1S2473 VE	45-3-23
10-D34to42	ED308952	Germanium Diode 1K34A-LR	45-3-47
10-D43to45	ED316143	Silicon Diode 1S2473-HS	45-3-53
10-D46	ED306109	Silicon Diode W03B	45-2-78
10-D47to49	ED224550	Silicon Diode 10D4	45-2-16
10-D50	ED281621	Zener Diode WZ-071	45-6-67
10-D51	ED316143	Silicon Diode 1S2473-HS	45-3-53
10-D52to54	ED560913	Silicon Diode 1S2473 VE	45-3-23
10-D55	ED308952	Germanium Diode 1K34A-LR	45-3-47
10-D56	ED494583	Silicon Diode 10D05	45-2-42
10-D57	ED560913	Silicon Diode 1S2473 VE	45-3-23
10-D58	ED494583	Silicon Diode 10D05	45-2-42
10-SW1	ES316169	Push SW. SUF-12 (SW. P.C Board Assy)	25-5-321
10-SW1	ES309094	Slide SW. SL13-6-6-2-2-B (U/T, JPN)	25-3-159
10-VR1	EV302718	Semi-Fixed/Vol. V18K3-6(4US) 50kB	36-9-26
10-VR2	EV309071	Semi-Fixed/Vol. V18K3-6 (4US) 20kB	36-9-26
10-RL1to3	EP324462	Relay MY4-02-US DC12V	47-1-42
10-RL4	EP308949	Relay BR211	47-2-31

When ordering parts, please quote Parts Number, Description and Model Number.

Symbol No.	Parts No.	Description	Schematic No.
10-CR1to7	ER300820	Spark Quencher CRU-112 0.1 μ +120 ohms 125WV	41-1-63
10-FR1	ER561216	Fuse/R. 1/4W 100 ohms (K) 200mA	35-14-9
10-F3	EF311839	Δ Fuse 1.6A 250V (U/T, JPN)	39-1-64
10-F3	EF308847	Δ Fuse 1.6A 125V (CSA, AAL)	39-1-65
10-F3	EF623103	Δ Fuse (Semko T) 1AT (CEE, UK, SAA)	39-1-53
10-F4	EF309388	Δ Fuse 800mA 250V (U/T, JPN)	39-1-64
10-F4	EF309391	Δ Fuse 800mA 125V (CSA, AAL)	39-1-65
10-F4	EF593706	Δ Fuse (Semko T) 500MAT (CEE, UK, SAA)	39-1-53
10-F5	EF306949	Δ Fuse 1.25A 250V (U/T, JPN)	39-1-64
10-F5	EF309392	Δ Fuse 1.25A 125V (CSA, AAL)	39-1-65
10-F5	EF602550	Δ Fuse (Semko T) 1.25AT 250V (CEE, UK, SAA)	39-1-53
10-F6	EF309388	Δ Fuse 800mA 250V (U/T, JPN)	39-1-64
10-F6	EF309391	Δ Fuse 800mA 125V (CSA, AAL)	39-1-65
10-F6	EF601942	Δ Fuse (Semko T) 630MAT (CEE, UK, SAA)	39-1-53
10-R4	ER311756	Metal Oxide Film/R. 1W 15 ohms (K)	35-19-1
10-R27	ER663298	Carbon/R. F 1/4W 330 ohms (J)	35-11-12
10-R28	ER233638	Carbon/R. F 1/4W 180 ohms (J)	35-11-12
10-R96	ER309092	Carbon/R. 2W 820 ohms (K)	35-15-8
10-R97	ER318415	Cement/R. 20W 360 ohms (K)	35-16-81
10-R98	ER308955	Cement/R. 20W 36 ohms (K)	35-16-81
10-R120	ER538064	Metal Oxide Film/R. 1W 68 ohms (K)	35-15-10
10-C1	EC316182	Elect./C. (Vert.) 2200 μ F 16WV	24-12-46
10-C2	EC316183	Elect./C. (Vert.) 1000 μ F 16WV	24-12-46
10-C4	EC316230	Elect./C. (Vert.) 2200 μ F 35WV	24-12-46
10-C7	EC322419	Elect./C. (Vert.) 3300 μ F 25WV	24-12-46
10-C39	EC316190	NP/C. 47 μ F (M) 10WV	24-17-31
10-C40	EC313534	NP/C. 10 μ F (M) 16WV	24-17-31
10-C41,42	EC313532	NP/C. 1 μ F (M) 50WV	24-17-31
10-C49,50	EC316194	Metallized Polyester/C. (Vert.) 0.4 μ F (K) 250WV	24-16-29
10-C51	EC316192	Metallized Compound/C. (Vert.) 1.5 μ F (K) 180WV (U/T, JPN, CEE, UK, SAA)	24-16-20
10-C52	EC316193	Metallized Compound/C. 3.5 μ F (J) 180VA	24-16-21
10-C55to68	EC316191	Metallized Polyester/C. (Vert.) 0.1 μ F (K) 250WV (CEE, UK, SAA)	24-16-19
10-C71	EC321146	Solid Aluminum/C. 0.22 μ F (M) 25WV	24-19-3
10-6	ZS421806	Screw, Pan 3x8	
10-7	ZW273756	Nut, #1 M3	

11. BRAKE CONTROL P.C BOARD BLOCK

Symbol No.	Parts No.	Description	Schematic No.
11-1	BA324729	Brake Control P.C Board Comp. GX-625	TG-5211
11-IC1to3	EI324682	IC TC4027BP	45-8-453
11-IC4	EI324686	IC HD14071BP	45-8-456
11-IC5	EI324690	IC HD14075BP	45-8-460
11-IC6,7	EI324694	IC HD14081BP	45-8-448
11-IC8	EI324699	IC HD14082BP	45-8-464
11-TR1	ET554657	Transistor 2SA733(P)(Q)	45-1-124
11-TR2to4	ET639437	Transistor 2SC945L(Q)(P)	45-1-85
11-TR6	ET429748	Transistor 2SC711(H)	45-1-67
11-TR7to21	ET639437	Transistor 2SC945L(Q)(P)	45-1-85
11-TR22	ET284264	FET 2SK68(L) 2	45-12-13
11-TR23,24	ET554657	Transistor 2SA733(P)(Q)	45-1-124
11-TR25	ET639437	Transistor 2SC945L(Q)(P)	45-1-85
11-TR26	ET554657	Transistor 2SA733(P)(Q)	45-1-124
11-TR27to30	ET639437	Transistor 2SC945L(Q)(P)	45-1-85
11-TR31	ET554657	Transistor 2SA733(P)(Q)	45-1-124
11-D4to6	ED560913	Silicon Diode 1S2473 VE	45-3-23
11-D7to11	ED308952	Germanium Diode 1K34A-LR	45-3-47
11-D12to21	ED560913	Silicon Diode 1S2473 VE	45-3-23
11-VR1	EV464207	Semi-Fixed/Vol. V8K4-1 5 kB	36-10-266
11-PH1	EZ324787	Photo Coupler TLP504	45-18-4
11-IND1	EL324540	Lamp (Fuse Type) 12V 55mA	28-2-85
11-R61	ER324649	Metal Oxide Film/R. 1W 47 ohms (J)	35-11-18
11-C20	EC223560	Solid Aluminum/C. (Vert.) 0.1 μ F (M) 16WV	24-19-2
11-C24	EC223560	Solid Aluminum/C. (Vert.) 0.1 μ F (M) 16WV	24-19-2
11-C25	EC325645	Polyester Film/C. (Vert.) 0.01 μ F (K) 50WV	24-1-15

12. TIME IND. P.C BOARD BLOCK

Symbol No.	Parts No.	Description	Schematic No.
12-1	BA320142	Time Ind. P.C Board Comp. GX-625	TG-5215
12-IC1,2	EI324681	IC HD14027BP	45-8-452
12-IC3	EI310183	IC MC1400BCP	45-8-121
12-TR1	ET639437	Transistor 2SC945L(Q)(P)	45-1-85
12-TR2	ET638504	Transistor 2SC945L(P)	45-1-85
12-TR3,4	ET639437	Transistor 2SC945L(Q)(P)	45-1-85
12-TR6,7	ET554657	Transistor 2SA733(P)(Q)	45-1-124
12-TR8	ET639437	Transistor 2SC945L(Q)(P)	45-1-85
12-D1to11	ED316143	Silicon Diode 1S2473-HS	45-3-53
12-D12,13	ED308952	Germanium Diode 1K34A-LR	45-3-47
12-D14	ED316143	Silicon Diode 1S2473-HS	45-3-53
12-D16,17	ED560913	Silicon Diode 1S2473 VE	45-3-23
12-D18,19	ED316143	Silicon Diode 1S2473-HS	45-3-53
12-D20,21	ED560913	Silicon Diode 1S2473 VE	45-3-23
12-2	ZS325495	Tapping Screw, #2 BR 3x6	

13. THYRISTOR P.C BOARD BLOCK

Symbol No.	Parts No.	Description	Schematic No.
13-1	BA324722	Thyristor P.C Board Comp. GX-625	TG-5210
13-D1to4	ED224550	Silicon Diode 10D4	45-2-16
13-D5to8	ED324669	Silicon Diode 10D4-FA-2	45-3-61
13-D9	ED306109	Silicon Diode W03B	45-2-78
13-RL1	EP324672	Relay 321D012	47-2-36
13-SCR1,2	ED324667	Thyristor 2P1M	45-13-7
13-SCR3,4	EI324668	Triac AC03BGM-L	45-13-6
13-CR3,4	ER300820	Spark Quencher CRU-112 0.1 μ +120 ohms 125WV	41-1-63
13-CR6	ER300820	Spark Quencher CRU-112 0.1 μ +120 ohms 125WV	41-1-63
13-FR1	ER326169	Fuse/R. F 1/4W 22 ohms (G)	35-14-31
13-FR2,3	ER326167	Fuse/R. 20W 39 ohms (K)	35-14-32
13-FR4to6	ER320528	Fuse/R. F 1/4W 22 ohms (G)	35-14-30
13-R3,4	ER324670	Metal Oxide Film/R. 2W 1K (J)	35-11-22
13-C1	EC316194	Metallized Polyester/C. (Vert.) 0.4 μ F (K) 250WV	24-16-29
13-2	ZS422076	Screw, Pan 3x5	

14. FUSE P.C BOARD BLOCK

Symbol No.	Parts No.	Description	Schematic No.
14-1	BA324712	Fuse P.C Board Comp. GX-625 (U/T)	TG-5208
14-2	BA324713	Fuse P.C Board Comp. GX-625 (JPN)	TG-5208
14-3	BA324714	Fuse P.C Board Comp. GX-625 (CSA)	TG-5208
14-4	BA324715	Fuse P.C Board Comp. GX-625 (CEE) (CEE, UK, SAA)	TG-5208
14-TR1	ET375603	Transistor 2SC1061(B)(C)	45-1-96
14-TR2to5	ET639437	Transistor 2SC945L(Q)(P)	45-1-85
14-D1	ED494583	Silicon Diode 10D05	45-2-42
14-D2	ED510772	Zener Diode WZ-120	45-6-67
14-D4,5	ED560913	Silicon Diode 1S2473 VE	45-3-23
14-D6	ED308952	Germanium Diode 1K34A-LR	45-3-47
14-D7	ED491130	Zener Diode WZ-085	45-6-67
14-F1	EF258344	Δ Fuse (Semko T) 800MAT (U/T, CEE, SAA, UK)	39-1-53
14-F1	EF309388	Δ Fuse 800mA 250V (JPN)	39-1-64
14-F1	EF309391	Δ Fuse 800mA 125V (CSA, AAL)	39-1-65
14-F2	EF691007	Δ Fuse (Semko T) 3.15AT (U/T, CEE, SAA, UK)	39-1-53
14-F2	EF326639	Δ Fuse 3.15A 250V (JPN)	39-1-64
14-F2	EF323080	Δ Fuse 3.15A 125V (CSA, AAL)	39-1-65
14-C1	EC321628	Elect./C. (Vert.) 3300 μ F 25WV	24-12-44
14-C9	EC551160	Ceramic/C. DB821 NA 0.01 μ F (Z) 1.4KWV(U/T)	24-5-55
14-C9	EC321302	Ceramic/C. E 0.01 μ F (Z) 250VAC (JPN)	24-5-90
14-C9	EC314688	Ceramic/C. DE7150 FZ 0.01 μ F (P) 125WV (CSA, AAL)	24-5-87
14-C9	EC327382	MP/C. (Vert.) 0.0047 μ F (M) 250WV (CEE, UK, SAA)	24-9-134
14-C10	EC327382	MP/C. (Vert.) 0.0047 μ F (M) 250WV (CEE, UK, SAA)	24-9-134
14-5	ZS455207	Tapping Screw, #2 BR 3x5	
14-6	ZS422076	Screw, Pan 3x5	
14-7	ZS558101	Screw, Pan 3x6 w/Washer	

When ordering parts, please quote Parts Number, Description and Model Number.

15. COUNTER P.C BOARD BLOCK

Symbol No.	Parts No.	Description	Schematic No.
15-IC1	EI324675	IC LM8523	45-8-479
15-IC2	EI310183	IC MC1400BCP	45-8-121
15-IC3	EI696363	IC MC14049BCP	45-8-171
15-IC4	EI324789	IC MC14078BCP	45-8-466
15-IND1	ED324676	LED, 4 Figures	
		7 Segments SL-1476-04W	59-2-2
15-SW1to6	ES324677	Sensi Touch SW.	
		KEC11902	25-9-14
15-SW7	ES323367	Sensi Touch SW.	
		KEC10001	25-9-9
15-C7to9	EC324586	Tantalum/C. 4.7 μ F(M)	
		16WV	24-15-12

16. FILTER P.C BOARD BLOCK

Symbol No.	Parts No.	Description	Schematic No.
16-L1	EO318363	Inductor LAL04 22 μ H(K)	23-1-313
16-C1	EC316183	Elect./C. (Vert.)	
		1000 μ F 16WV	24-12-46
16-C2	EC319459	Oil Paper/C.	
		0.0047 μ F(M) 450VAC	
		(U/T, CEE, UK, SAA)	24-8-8
16-C2	EC319457	Ceramic/C. Type DL	
		(Vert.) E 0.0047 μ F(Z)	
		150VAC (JPN)	24-5-106
16-C2	EC325266	Ceramic/C. DE7100	
		0.0047 μ F (P) 125VAC	
		(CSA, AAL)	24-5-87
16-C3	EC319459	Oil Paper/C.	
		0.0047 μ F(M) 450VAC	
		(U/T, CEE, UK, SAA)	24-8-8
16-C3	EC319457	Ceramic/C. Type DL	
		(Vert.) E 0.0047 μ F (Z)	
		150VAC (JPN)	24-5-106
16-C3	EC325266	Ceramic/C. DE7100	
		0.0047 μ F (P)	
		125VAC (CSA, AAL)	24-5-87

17. DETECTION P.C BOARD BLOCK

Symbol No.	Parts No.	Description	Schematic No.
17-TR1to3	ET324539	Photo Transistor PT-410	45-18-5
17-1	ZS609120	Tapping Screw, #2 Pan 3x6	

18. FINAL ASSEMBLY BLOCK

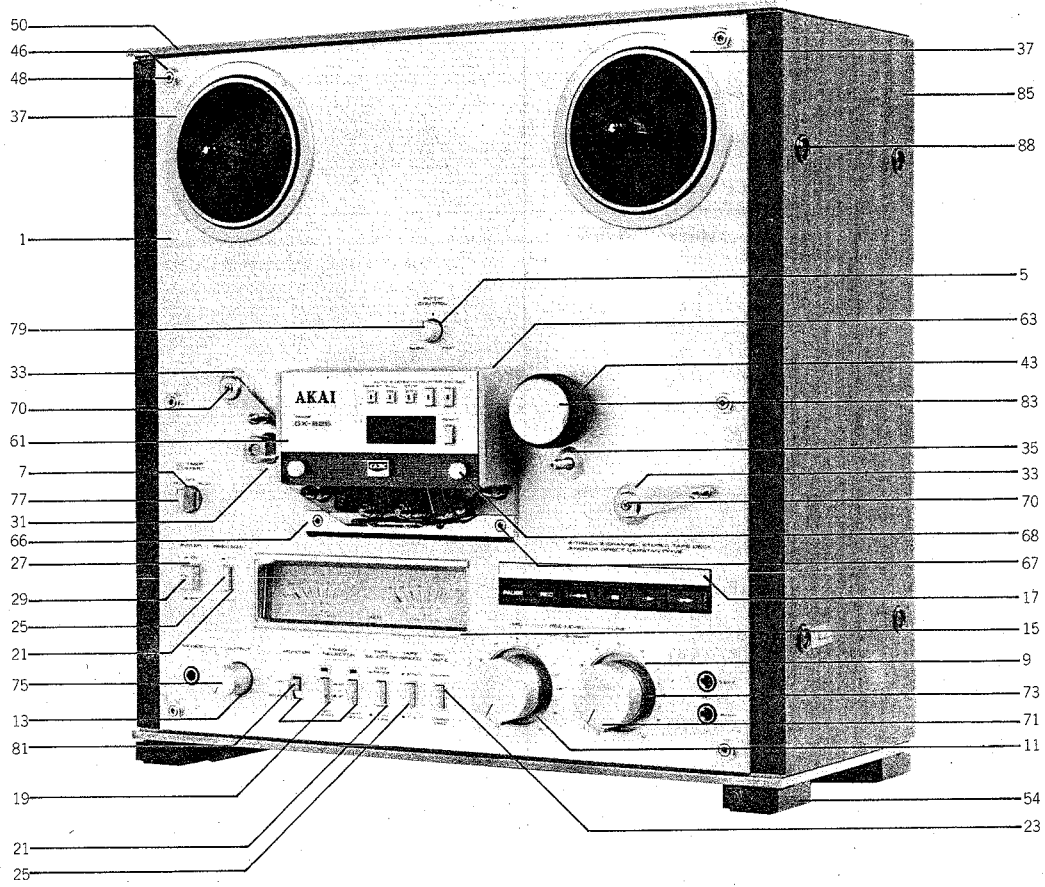

FINAL ASSEMBLY BLOCK

Ref. No.	Parts No.	Description	Schematic No.	Ref. No.	Parts No.	Description	Schematic No.
18-1	BD324762	Front Panel BLK GX-625(U/T)	TG-6221	18-71	SK314221	Double Knob (Upper) Part	
18-2x	BD324763	Front Panel BLK GX-625(JPN)	TG-6221			GX-620	TG-6028
18-3x	BD324765	Front Panel BLK GX-625-BL	TG-6221	18-72x	SK314258	Double Knob (Upper-BL) Part	
18-4x	BD326851	Front Panel BLK GX-625-BL (JPN)	TG-6221			GX-620-BL	TG-6028
18-5	SE316069	Pitch Control Escutcheon	TG-6004	18-73	SK316097	Double Knob (Lower)	TG-6030
18-5x	SE324549	Pitch Control Escutcheon (BL)	TG-6004	18-74x	SK316679	Double Knob (Lower-BL)	TG-6030
18-7	SE316070	Timer Escutcheon	TG-6005	18-75	SK314220	Knob (C) Part GX-620	TG-6032
18-8x	SE324550	Timer Escutcheon (BL)	TG-6005	18-76x	SK314259	Knob (C-BL) Part GX-620-BL	TG-6032
18-9	SE316072	Vol. Escutcheon (A)	TG-6007	18-77	SK316099	Knob (D)	TG-6033
18-10x	SE316661	Vol. Escutcheon (A-BL)	TG-6007	18-78x	SK324552	Knob (D-BL)	TG-6033
18-11	SZ316115	Decoration Ring	TG-6048	18-79	SK316100	Knob (E)	TG-6034
18-12x	SZ316683	Decoration Ring (BL)	TG-6048	18-80x	SK324553	Knob (E-BL)	TG-6034
18-13	SE316071	Vol. Escutcheon (B)	TG-6006	18-81	SK316111	Lever Knob	TG-6045
18-14x	SE319521	Vol. Escutcheon (B-BL)	TG-6006	18-82x	SK316682	Lever Knob (BL)	TG-6045
18-15	SE316076	Meter Escutcheon	TG-6011	18-83	SK314229	Pinch Roller Cap Part GX-620	TD-6013
18-16x	SE316665	Meter Escutcheon (BL)	TG-6011	18-84x	SK314260	Pinch Roller Cap (BL) Part	
18-17	SE316077	Operation Escutcheon	TG-6012			GX-620-BL	TD-6013
18-18x	SE316666	Operation Escutcheon (BL)	TG-6012	18-85	SP316101	Side Cover (A)	TG-6035
18-19	SE316079	SW. Escutcheon (A)	TG-6013	18-86x	SP316120	Side Cover (B) (JPN)	TG-6035
18-20x	SE316667	SW. Escutcheon (A-BL)	TG-6013	18-87x	SP316681	Side Cover (BL)	TG-6035
18-21	SE316081	SW. Escutcheon (B-1)	TG-6014	18-88	ZS318423	Screw (B), w/Spot Facing	
18-22x	SE316668	SW. Escutcheon (B-1-BL)	TG-6014			Washer	TH-6057
18-23	SE316118	SW. Escutcheon (B-2)	TG-6014	18-89x	ZS324342	Screw (E), Slide Type	
18-24x	SE316669	SW. Escutcheon (B-2-BL)	TG-6014			w/Washer	TH-6057
18-25	SK316082	Knob (A)	TG-6015	18-90x	ZW305013	Pop Rivet D3.2 (AAL)	7-6-9
18-26x	SK316670	Knob (A-BL)	TG-6015				
18-27	SE316084	Power Knob Escutcheon	TG-6017				
18-28x	SE316671	Power Knob Escutcheon (BL)	TG-6017				
18-29	SK316085	Knob (B)	TG-6018				
18-30x	SK316672	Knob (B-BL)	TG-6018				
18-31	SE316073	Tape Roller Escutcheon	TG-6008				
18-32x	SE316662	Tape Roller Escutcheon (BL)	TG-6008				
18-33	SE316074	Tension Arm Escutcheon	TG-6009				
18-34x	SE316663	Tension Arm Escutcheon (BL)	TG-6009				
18-35	SE316075	Capstan Escutcheon	TG-6010				
18-36x	SE316664	Capstan Escutcheon (BL)	TG-6010				
18-37	SE315931	Reel Table Escutcheon (2-C)	TD-6021				
18-38x	SE315577	Reel Table Escutcheon (2-D) (BL)	TD-6021				
18-39x	ZG316083	Button Spring	TG-6016				
18-40x	ZW316688	Nylon Rivet (Male) 4x5	2-7-57				
18-41x	ZG316086	Power Button Spring	TG-6019				
18-42x	ZW575730	Speed Nut (P Type) (3)	6-3-6				
18-43	MP582164	Pinch Roller D=42	TD-1034				
18-44x	ZW376391	Washer (Polyslider) D6.1x10x0.13t					
18-45x	ZS527681	Pinch Roller Set Screw	ND-6019				
18-46	ZW315917	Decoration Washer	TG-6020				
18-47x	ZW316673	Decoration Washer (BL)	TG-6020				
18-48	ZS613901	Panel Screw	CW-6031				
18-49x	ZS306435	Panel Screw (C) (BL)	CW-6031				
18-50	SP316087	Cover	TG-6021				
18-51x	SP316674	Cover (BL)	TG-6021				
18-52x	ZS316650	Screw, Pan 4x8					
18-53x	ZS201778	Screw, Pan Head 4x8 (Black)					
18-54	SA314222	Squar Foot Part GX-620	TG-6022				
18-55x	ZS520525	Screw, Bind 4x25 (Black)					
18-56	SP324640	Back Board (U/T-2)	TG-6216,6212				
18-57x	SP324644	Back Board (JPN-2)	TG-6216,6215				
18-58x	SP324642	Back Board (CSA, AAL-2)	TG-6216,6213				
18-59x	SP324643	Back Board (CEE, UK, SAA-2)	TG-6216,6214				
18-60	ZS297641	Tapping Screw #2, Bind 3x8 W=10					
18-61	BZ324774	Head Cover Plate Assy GX-625	TG-6222				
18-62x	BZ324776	Head Cover Plate Assy GX-625-BL	TG-6222				
18-63	BZ324777	Head Cover Assy GX-625	TG-6223				
18-64x	BZ324778	Head Cover Assy GX-625-BL	TG-6223				
18-65x	ZS421806	Screw, Pan 3x8					
18-66	SP316094	Decoration Panel	TG-6027				
18-67	ZS316114	Panel Screw	TG-6047				
18-68	ZS322429	Decoration Screw (B)	CF-6210				
18-69x	ZS322430	Decoration Screw (B-BL)	CF-6210				
18-70	ZS411660	Screw, Oval Countersunk 3x6					

When ordering parts, please quote Parts Number, Description and Model Number.

INDEX

Parts No.	Ref. No. & Symbol No.	Parts No.	Ref. No. & Symbol No.	Parts No.	Ref. No. & Symbol No.	Parts No.	Ref. No. & Symbol No.
BA320142	12-1	ED308941	10-D4	EI324668	13-SCR3,4	ET308947	6-2
BA324705	9-1	ED308952	10-D20to23	EI324675	15-IC1	ET310832	10-TR24
BA324706	9-2	ED308952	10-D31	EI324681	12-IC1,2	ET313717	9-TR13
BA324707	9-3	ED308952	10-D34to42	EI324682	11-IC1to3	ET316171	10-TR3
BA324712	14-1	ED308952	10-D55	EI324686	11-IC4	ET316171	10-TR5to9
BA324713	14-2	ED308952	11-D7to11	EI324690	11-IC5	ET316171	10-TR15to22
BA324714	14-3	ED308952	12-D12,13	EI324694	11-IC6,7	ET324539	17-TR1to3
BA324715	14-4	ED308952	14-D6	EI324699	11-IC8	ET352146	9-TR1to3
BA324722	13-1	ED308953	9-D2	EI324789	15-IC4	ET352146	9-TR8to10
BA324729	11-1	ED308953	9-D4,5	EI696363	15-IC3	ET375603	10-TR2
BA324732	10-1	ED308953	9-D12	EJ249467	6-17	ET375603	10-TR4
BA324733	10-2	ED309069	10-D5	EJ262732	6-16	ET375603	14-TR1
BA324734	10-3	ED310584	7-2x	EJ301513	6-13x	ET429748	11-TR6
BA324735	10-4	ED310585	7-1	EJ306289	9-J1	ET554657	10-TR10to12
BA324736	10-5	ED316143	10-D29	EJ306985	9-J3	ET554657	10-TR14
BD324762	18-1	ED316143	10-D32	EJ307274	6-5	ET554657	11-TR1
BD324763	18-2x	ED316143	10-D43to45	EJ308986	9-J3	ET554657	11-TR23,24
BD324765	18-3x	ED316143	10-D51	EJ310203	7-8	ET554657	11-TR26
BD326851	18-4x	ED316143	12-D1to11	EJ316129	2-24x	ET554657	11-TR31
BH314075	2-1x	ED316143	12-D14	EJ316130	2-25x	ET554657	12-TR6,7
BI314142	5-1	ED316143	12-D18,19	EJ316156	9-J2	ET638504	12-TR2
BK314428	8-46	ED318292	9-D1	EL316167	8-52	ET639437	9-TR4,5
BL314071	8-38	ED318292	9-D3	EL324540	11-IND1	ET639437	9-TR11,12
BL314141	5-13	ED318292	9-D8to10	EM316135	7-6	ET639437	9-TR14
BM308310	3-1x	ED324013	10-D6	EM316689	7-7x	ET639437	9-TR16to20
BM587518	4-1	ED324667	13-SCR1,2	EO301467	9-L1	ET639437	11-TR2to4
BR587542	4-2x	ED324669	13-D5to8	EO316141	9-VL2	ET639437	11-TR7to21
BR587553	4-3x	ED324676	15-IND1	EO316142	9-L2	ET639437	11-TR25
BT324656	6-7	ED326168	10-D3	EO318363	16-L1	ET639437	11-TR27to30
BT324657	6-8x	ED491130	14-D7	EO346230	9-VL1	ET639437	12-TR1
BT324658	6-10x	ED494583	10-D1,2	EO346230	9-VL3	ET639437	12-TR3,4
BT324659	6-9x	ED494583	10-D56	EO383365	9-T1	ET639437	12-TR8
BZ283432	5-3	ED494583	10-D58	EP308949	10-RL4	ET639437	14-TR2to5
BZ308315	3-5	ED494583	14-D1	EP308973	9-RL1	ET666404	10-TR26
BZ324774	18-61	ED510772	10-D7,8	EP309056	7-10	EV302718	10-VR1
BZ324776	18-62x	ED510772	14-D2	EP309056	8-2	EV309071	10-VR2
BZ324777	18-63	ED560913	9-D6,7	EP315918	7-12	EV313538	7-14
BZ324778	18-64x	ED560913	9-D11	EP315918	8-9	EV313538	9-VR5
EC223560	11-C20	ED560913	10-D9to19	EP316121	7-11	EV315540	9-VR6
EC223560	11-C24	ED560913	10-D24to28	EP316121	8-7	EV315541	9-VR4
EC306420	9-C28	ED560913	10-D30	EP324462	10-RL1to3	EV315751	7-13
EC313532	10-C41,42	ED560913	10-D33	EP324672	13-RL1	EV315751	9-VR1,2
EC313534	10-C40	ED560913	10-D52to54	ER233638	10-R28	EV315753	9-VR3
EC314688	14-C9	ED560913	10-D57	ER300820	10-CR1to7	EV315928	8-41
EC316065	6-19	ED560913	11-D4to6	ER300820	13-C3,4	EV464207	11-VR1
EC316149	9-C29	ED560913	11-D12to21	ER300820	13-CR6	EW305691	6-23x
EC316150	9-C44	ED560913	12-D16,17	ER308898	9-FR1	EW306427	6-22x
EC316182	10-C1	ED560913	12-D20,21	ER308955	10-R98	EW306428	6-21
EC316183	10-C2	ED560913	14-D4,5	ER309092	10-R96	EW315767	6-31x
EC316183	16-C1	EF258344	6-25	ER311756	10-R4	EW322400	6-32x
EC316190	10-C39	EF258344	14-F1	ER316144	9-R76	EW322401	6-33x
EC316191	10-C55to68	EF306949	10-F5	ER318415	10-R97	EZ324787	11-PH1
EC316192	10-C51	EF308847	10-F3	ER320528	13-FR4to6	EZ631945	6-24
EC316193	10-C52	EF309388	6-27x	ER322787	9-R40,41	HA316007	2-13
EC316194	10-C49,50	EF309388	10-F4	ER324649	11-R61	HA316009	2-18
EC316194	13-C1	EF309388	10-F6	ER324670	13-R3,4	HA321735	2-22
EC316230	10-C4	EF309388	14-F1	ER326167	13-FR2,3	HE311139	2-21
EC319457	16-C2	EF309391	6-29x	ER326169	13-FR1	HP318522	2-10
EC319457	16-C3	EF309391	10-F4	ER538064	10-R120	HR308148	2-17
EC319457	16-C2	EF309391	10-F6	ER561216	10-FR1	HZ301366	2-11
EC319459	16-C3	EF309391	14-F1	ER663298	10-R27	HZ316005	2-8
EC321146	10-C71	EF309392	10-F5	ES306430	6-14x	HZ316006	2-15
EC321173	9-C70	EF311839	10-F3	ES309059	8-54	HZ316008	2-20
EC321302	14-C9	EF323080	6-30x	ES309094	10-SW1	HZ532710	2-5
EC321628	14-C1	EF323080	14-F2	ES310333	8-55x	MB324611	8-56
EC322419	10-C7	EF326639	6-28x	ES315747	9-SW6	MB606712	8-30
EC324586	15-C7to9	EF326639	14-F2	ES316117	8-42	MB665561	5-5
EC325266	16-C2	EF593706	10-F4	ES316159	9-SW1to5	MB668801	8-32
EC325266	16-C3	EF601942	10-F6	ES316169	10-SW1	MH316004	2-4
EC325644	6-20	EF602550	10-F5	ES323367	15-SW7	MH316022	8-22
EC325645	11-C25	EF623103	10-F3	ES324677	15-SW1to6	MI305146	5-11
EC327382	14-C9	EF691007	6-26	ES562465	8-34	ML314426	8-31
EC327382	14-C10	EF691007	14-F2	ES573478	8-26	ML692504	5-21
EC551160	14-C9	EI304165	10-IC4,5	ET284264	11-TR22	ML694506	5-25
EC558202	9-VC1	EI304166	10-IC6	ET302502	10-TR27	MP582164	8-62
ED224550	10-D47to49	EI306141	9-IC1	ET304181	9-TR6,7	MP582164	18-43
ED224550	13-D1to4	EI308936	10-IC1	ET307349	9-TR15	MR324582	8-57
ED281621	10-D50	EI310183	12-IC3	ET307349	10-TR1	MS301415	5-9
ED306109	10-D46	EI310183	15-IC2	ET308937	10-TR23	MS342000	4-5
ED306109	13-D9	EI316170	10-IC2,3	ET308937	10-TR25	MT314987	8-29

INDEX

Parts No.	Ref. No. & Symbol No.	Parts No.	Ref. No. & Symbol No.	Parts No.	Ref. No. & Symbol No.	Parts No.	Ref. No. & Symbol No.
MT436860	4-11	ZG321132	8-1	ZW270156	8-39		
MT534666	4-4	ZG466312	2-6	ZW270191	5-2		
MT534677	4-7	ZG540617	4-6	ZW273756	6-4		
MT534688	4-9	ZG580522	8-13	ZW273756	8-15x		
MV368886	3-7	ZG659608	5-17	ZW273756	10-7		
MZ397181	8-12	ZG672478	8-43	ZW274026	8-18		
MZ580680	8-35	ZS200384	5-24	ZW290283	8-4		
MZ597690	3-8	ZS201508	3-6	ZW301378	5-10		
SA314222	18-54	ZS201778	18-53x	ZW302052	5-23		
SB316162	8-47	ZS201802	8-44x	ZW305013	18-90x		
SB316163	8-48	ZS297641	18-60	ZW315917	18-46		
SB316164	8-49	ZS302699	7-9	ZW316011	2-26		
SB316165	8-50	ZS304464	2-23	ZW316136	8-36		
SB316166	8-51	ZS304806	2-14	ZW316673	18-47x		
SE315577	18-38x	ZS306435	18-49x	ZW316688	18-40x		
SE315931	18-37	ZS310343	8-60x	ZW376391	8-63		
SE316069	18-5	ZS316114	18-67	ZW376391	18-44x		
SE316070	18-7	ZS316119	8-53	ZW413188	8-16x		
SE316071	18-13	ZS316650	18-52x	ZW413267	6-12		
SE316072	18-9	ZS318423	18-88	ZW413278	3-9		
SE316073	18-31	ZS322429	18-68	ZW413278	8-17		
SE316074	18-33	ZS322430	18-69x	ZW420682	8-11		
SE316075	18-35	ZS323728	8-25	ZW462205	5-26		
SE316076	18-15	ZS324342	18-89x	ZW462205	8-19x		
SE316077	18-17	ZS325495	6-1	ZW560226	5-22		
SE316079	18-19	ZS325495	7-3	ZW575730	18-42x		
SE316081	18-21	ZS325495	8-21x	ZW575763	5-16		
SE316084	18-27	ZS325495	12-2	ZW580498	5-15		
SE316118	18-23	ZS379350	2-3	ZW597622	3-2		
SE316661	18-10x	ZS379350	5-20	ZW676045	8-58		
SE316662	18-32x	ZS380046	8-20x				
SE316663	18-34x	ZS411660	18-70				
SE316664	18-36x	ZS413201	2-9				
SE316665	18-16x	ZS413201	3-10				
SE316666	18-18x	ZS413201	8-14x				
SE316667	18-20x	ZS413245	8-45x				
SE316668	18-22x	ZS417150	2-2x				
SE316669	18-24x	ZS417150	8-24x				
SE316671	18-28x	ZS417216	8-8				
SE319521	18-14x	ZS419670	4-10				
SE324549	18-6x	ZS419670	8-27				
SE324550	18-8x	ZS421740	6-6				
SK314220	18-75	ZS421806	6-3				
SK314221	18-71	ZS421806	8-23				
SK314229	18-83	ZS421806	10-6				
SK314258	18-72x	ZS421806	18-65x				
SK314259	18-76x	ZS422076	5-12				
SK314260	18-84x	ZS422076	7-4				
SK316082	18-25	ZS422076	8-10				
SK316085	18-29	ZS422076	13-2				
SK316097	18-73	ZS422076	14-6				
SK316099	18-77	ZS424056	4-12				
SK316100	18-79	ZS432674	8-37x				
SK316111	18-81	ZS435273	6-11				
SK316670	18-26x	ZS447840	6-15x				
SK316672	18-30x	ZS447840	6-18				
SK316679	18-74x	ZS455207	14-5				
SK316682	18-82x	ZS483502	8-28x				
SK324552	18-78x	ZS498273	8-61x				
SK324553	18-80x	ZS499331	5-4				
SK597633	3-3	ZS520525	18-55x				
SP316087	18-50	ZS527681	8-64				
SP316094	18-66	ZS527681	18-45x				
SP316101	18-85	ZS539741	2-19				
SP316120	18-86x	ZS558101	5-7				
SP316674	18-51x	ZS558101	14-7				
SP316681	18-87x	ZS592378	8-3				
SP324640	18-56	ZS608308	3-4x				
SP324642	18-58x	ZS608321	5-18				
SP324643	18-59x	ZS608411	2-12				
SP324644	18-57x	ZS608501	2-16				
SZ316115	18-11	ZS609120	17-1				
SZ316683	18-12x	ZS613901	18-48				
ZG232121	5-6	ZW260010	5-8				
ZG308734	8-5	ZW260256	5-14				
ZG312947	5-19	ZW263946	7-5				
ZG312998	8-33	ZW265522	2-7				
ZG316040	8-40	ZW270088	4-8				
ZG316083	18-39x	ZW270088	8-6				
ZG316086	18-41x	ZW270101	8-59				

SECTION 3

SCHEMATIC DIAGRAM

1. SCHEMATIC DIAGRAM OF ICs
2. GX-625 NO. 3-1 1600444A POWER & SYS. CON SCHEMATIC DIAGRAM
3. GX-625 NO. 3-2 1600445A SCHEMATIC DIAGRAM
4. GX-625 NO. 3-3 1600446A PRE AMP SCHEMATIC DIAGRAM

LA4170

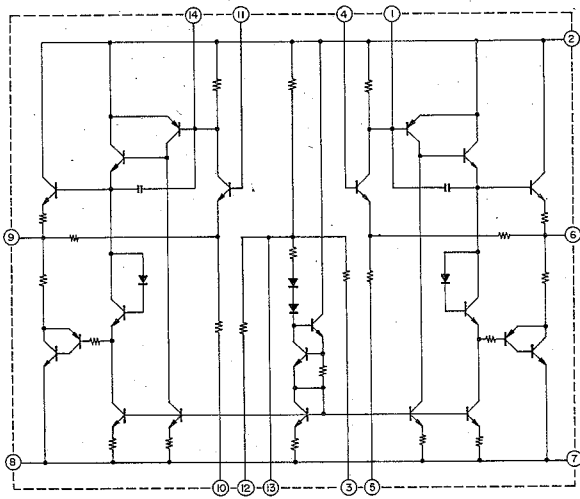

MB400M

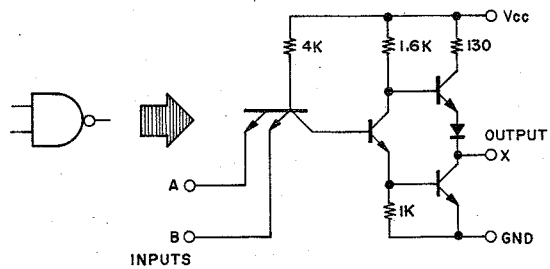
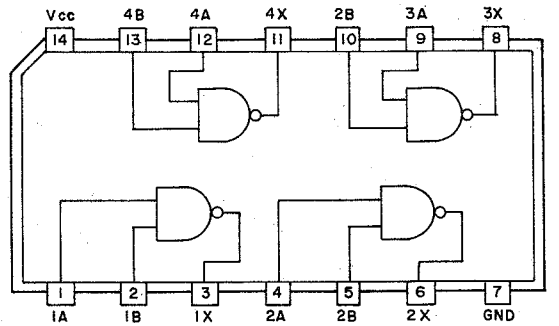

LB1270

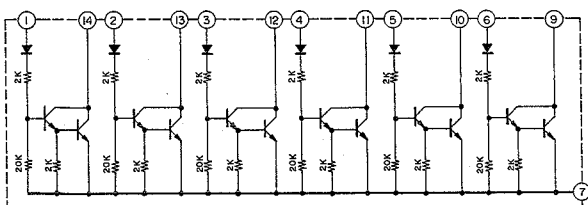

MB418

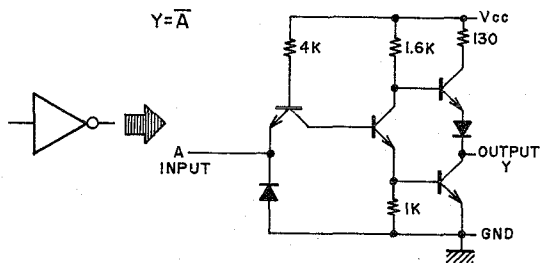
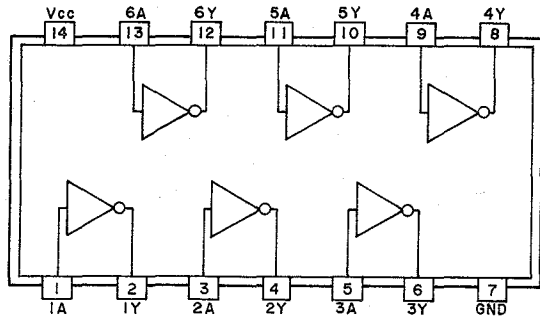

M54410P

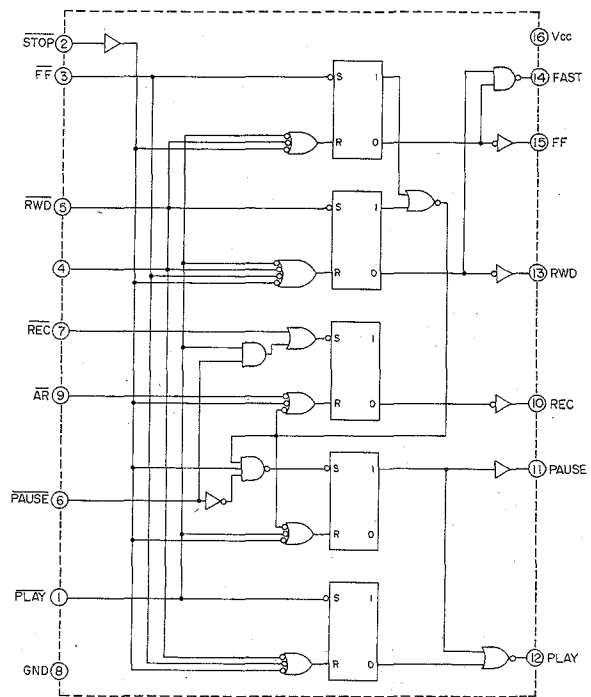

LM8529

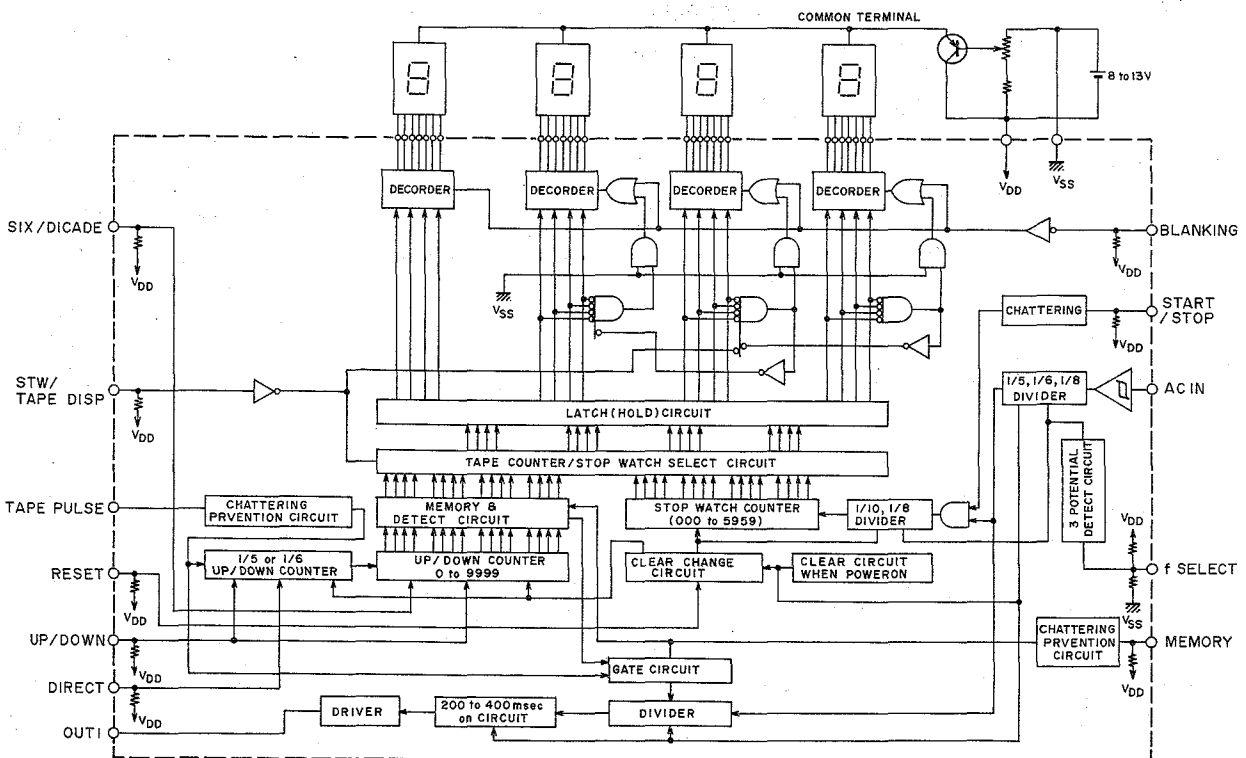

MC14049BCP

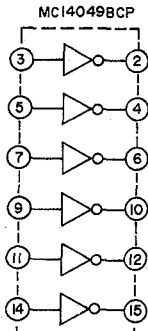

NC= Pin 13,16
VSS= Pin 8
VCC= Pin 1

MC14071BCP

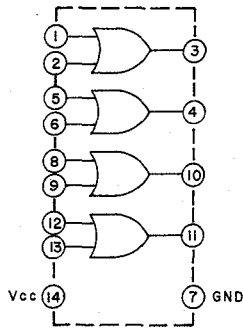

MC14081BCP

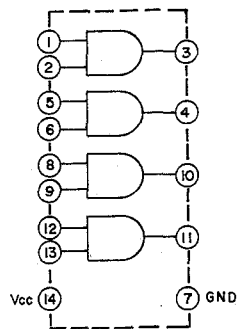

MC14078BCP

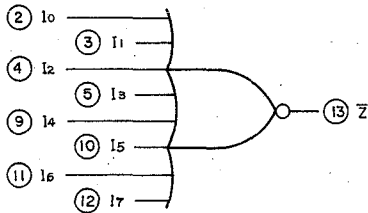
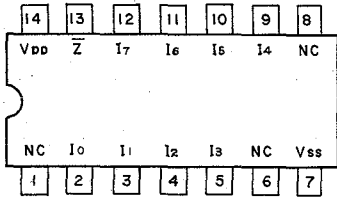

VDD = PIN 14
VSS = PIN 7
NC = PINS 1, 6, 8

MC14075BCP

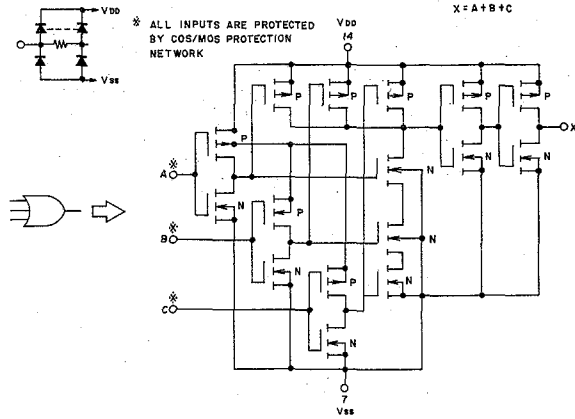
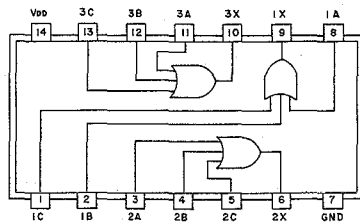

MC14001BCP

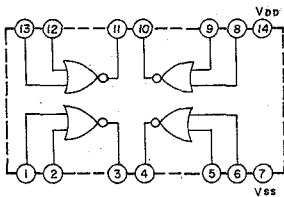

F4027BPC

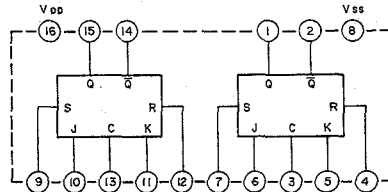

TC4027BP

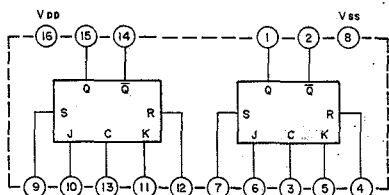

MC14082BCP

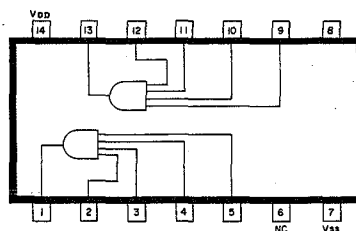

GX-625

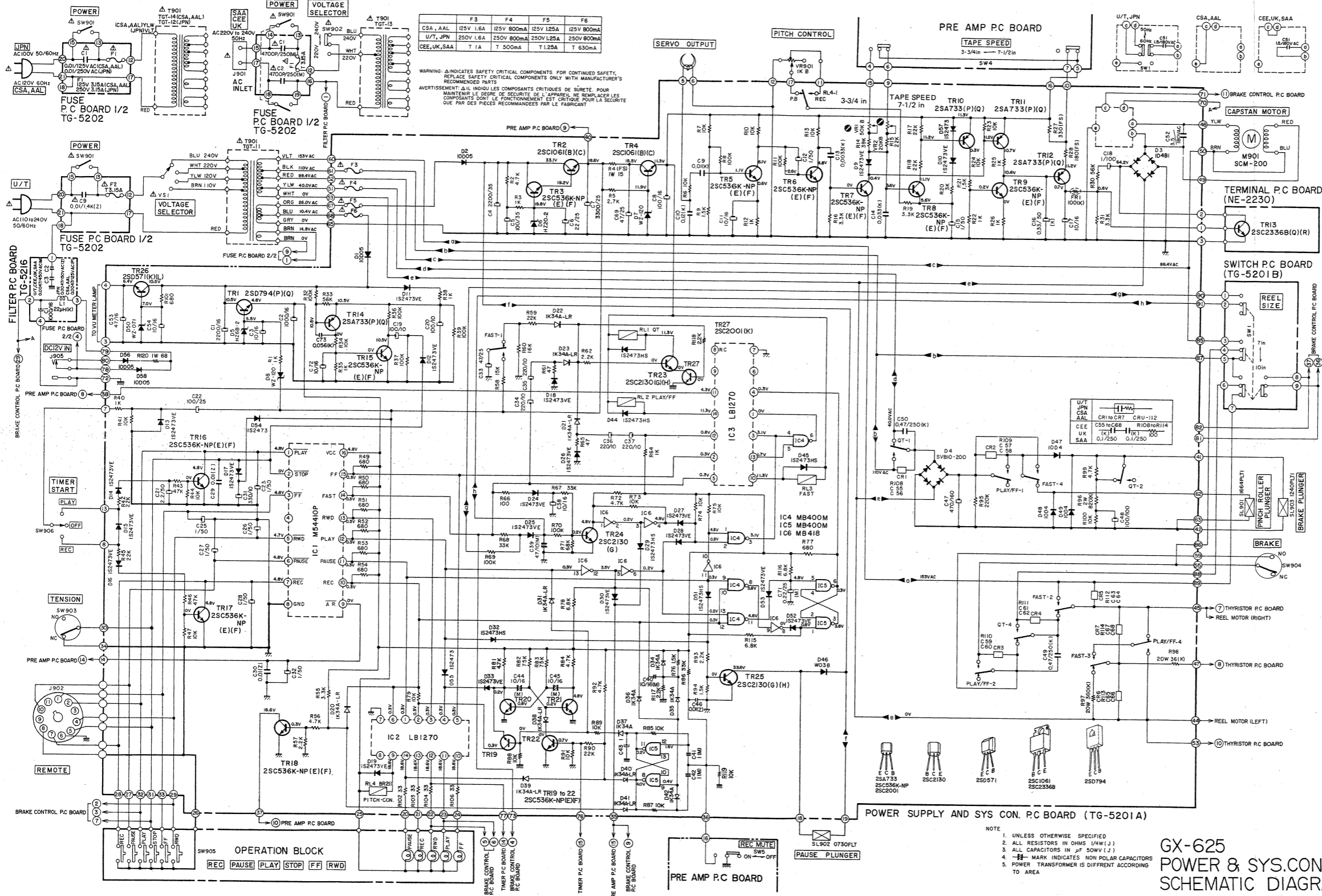

0010984

GX-625

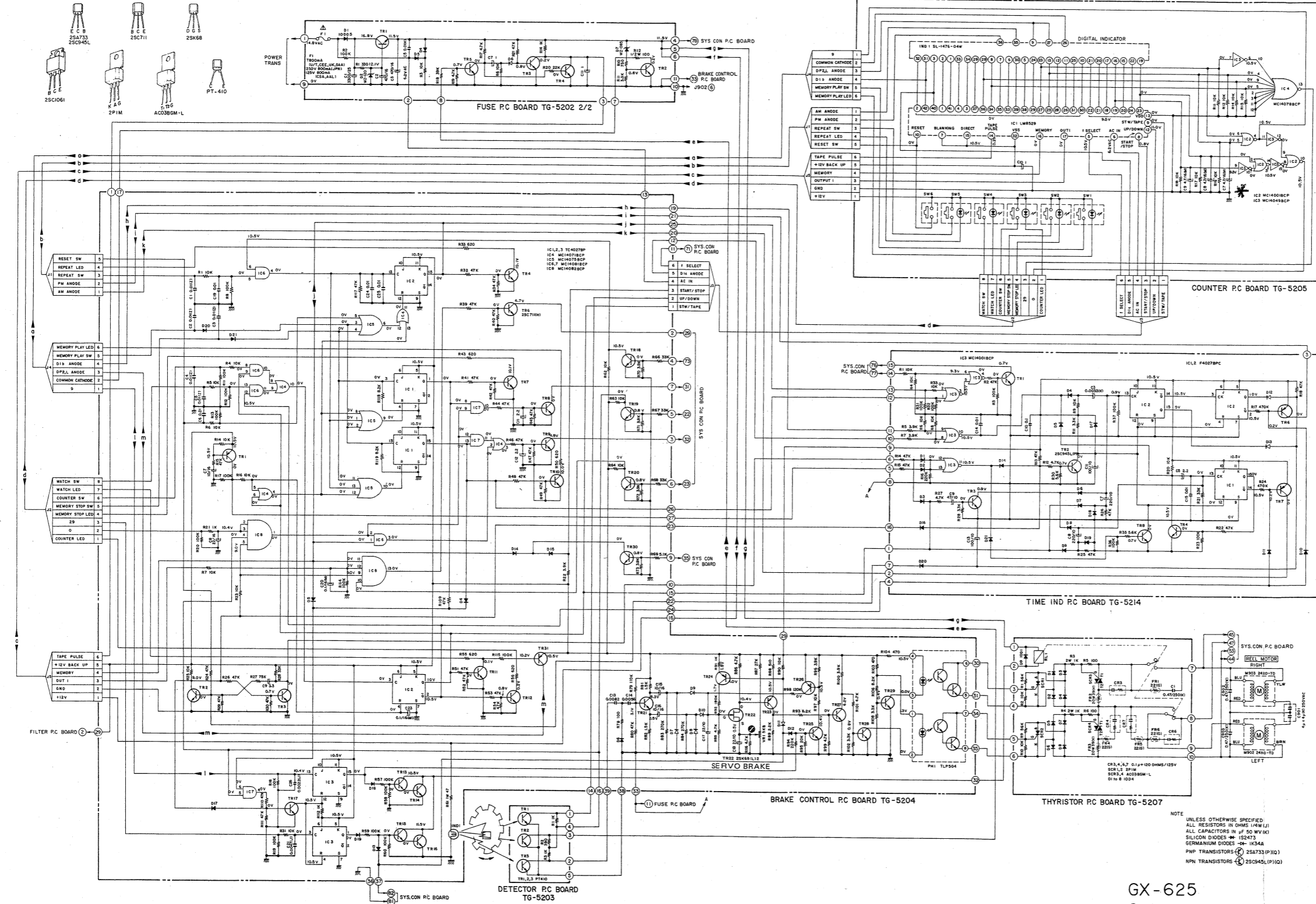

GX-625
 SCHEMATIC DIAGRAM
 NO.3-2 1600445A

GX-625

PRE AMP P.C BOARD TG-5001A

* REC MODE		
	7-1/2 in	3-3/4 in
TR17	B 0.2V	0.2V
	C 15.7V	12.8V
TR16	B 4.3V	11.7V
	C 13.7V	11.2V
TR6,7	E 0.5V	0.5V
	F 1.0V	1.0V
	G 1.5V	1.0V
T1	B 56.3V AC	47.2V AC
	G 96.3V AC	78.4V AC

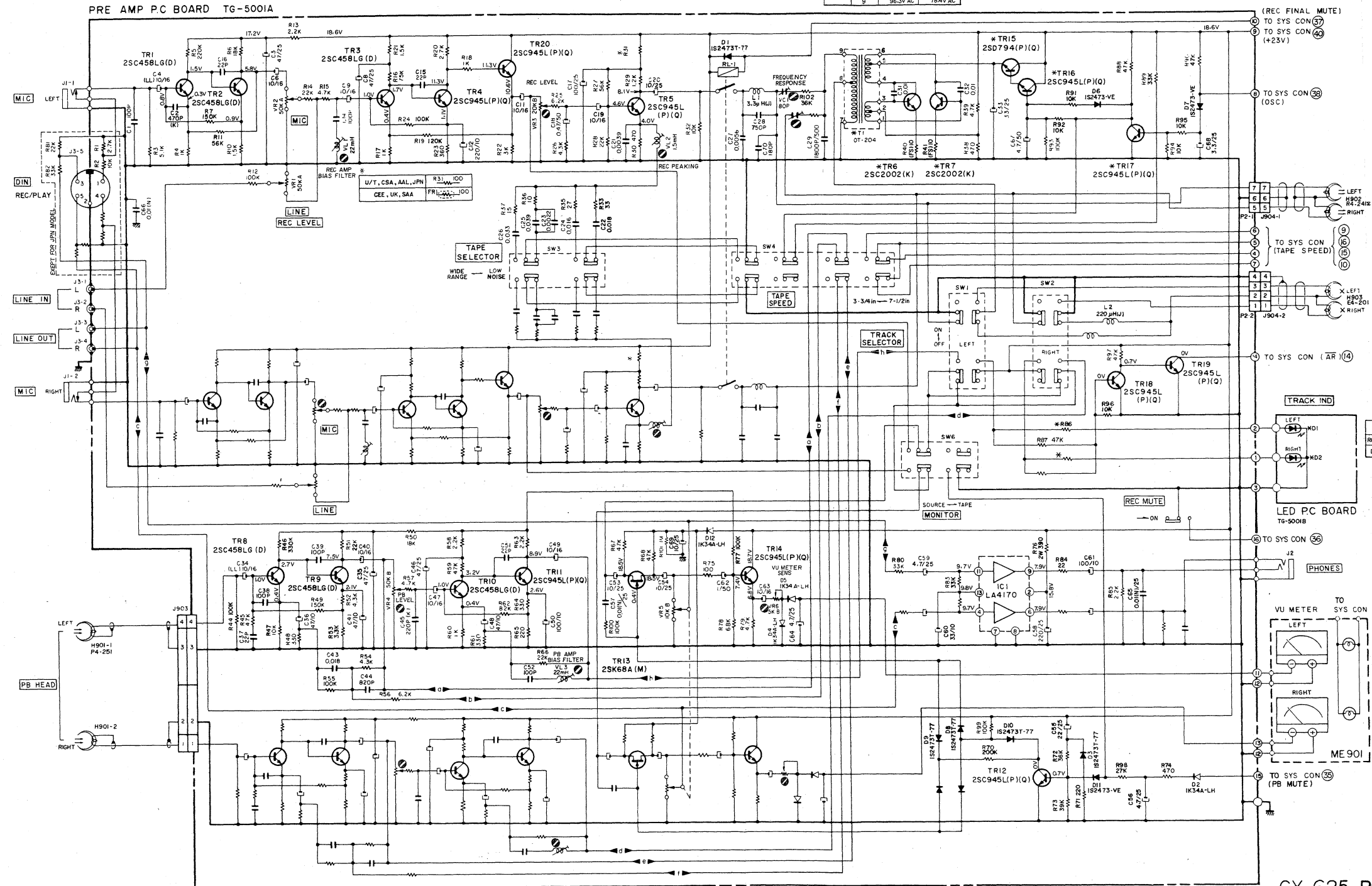

- E C B
 - 25C458L6
 - 25C945L
 - 25C2002K
 - D G S
 - 25K66
 - 25D794
- | * | JPN | OTHER MODELS |
|------|------|--------------|
| R86 | 4.3K | 1.5K |
| D1,2 | 9PR2 | 9PR2 |

NOTE
 UNLESS OTHERWISE SPECIFIED
 ALL RESISTORS IN OHMS 1/4W (1/2)
 ALL CAPACITORS IN P.F. 50MV (1)
 (LL): LOW LEAKAGE CAPACITOR

GX-625 PRE AMP
 SCHEMATIC DIAGRAM
 NO.3-3 1600446A