



## STEREO TAPE DECK

### MODEL GX-210D

SECTION 1	SERVICE MANUAL .....	3
SECTION 2	PARTS LIST .....	31
SECTION 3	SCHEMATIC DIAGRAM .....	56

---

---

---

SECTION 1

**SERVICE MANUAL**

TABLE OF CONTENTS

I.	SPECIFICATIONS .....	4
II.	MEASURING METHOD .....	6
	1. TAPE SPEED DEVIATION .....	6
	2. WOW AND FLUTTER .....	6
	3. FREQUENCY RESPONSE .....	6
	4. SIGNAL TO NOISE RATIO .....	6
	5. TOTAL HARMONIC DISTORTION FACTOR .....	7
	6. CROSS TALK .....	7
	7. ERASE RATIO .....	7
III.	DISMANTLING OF UNIT .....	8
IV.	SYSTEM CONTROL CIRCUIT OPERATION .....	10
	1. STOP MODE .....	13
	2. FORWARD PLAYBACK MODE .....	13
	3. FROM FWD TO REV PLAYBACK, AND AT REV PLAYBACK MODE .....	14
	4. FROM REVERSE TO FORWARD PLAYBACK .....	15
	5. RECORDING MODE .....	15
	6. FAST FORWARD AND REWIND MODE .....	15
	7. MUTING OPERATION .....	15
V.	MECHANISM ADJUSTMENTS .....	16
	1. REEL TABLE HEIGHT ADJUSTMENT .....	17
	2. PINCH WHEEL PRESSURE MEASURING METHOD .....	17
	3. BRAKE TENSION ADJUSTMENT .....	17
	4. LEFT AND RIGHT REEL MOTOR TENSION AT VARIOUS OPERATING MODES .....	18
	5. FLYWHEEL LOOSE PLAY ADJUSTMENT .....	18
	6. FLYWHEEL BELT POSITION ADJUSTMENT .....	18
VI.	HEAD ADJUSTMENTS .....	19
	1. HEAD HEIGHT ADJUSTMENT .....	19
	2. HEAD AZIMUTH ALIGNMENT ADJUSTMENT .....	19
VII.	AMPLIFIER ADJUSTMENTS .....	21
	1. PLAYBACK LEVEL ADJUSTMENTS .....	21
	2. VU METER SENSITIVITY ADJUSTMENT .....	24
	3. HIGH RANGE FREQUENCY DEVIATION CHECK .....	24
	4. RECORDING LEVEL ADJUSTMENT .....	24
	5. FREQUENCY RESPONSE ADJUSTMENT .....	25
	6. RECORDING BIAS FREQUENCY MEASURING METHOD .....	25
VIII.	D.C. RESISTANCE OF VARIOUS COIL .....	26
IX.	COMPOSITE VIEWS OF COMPONENTS .....	27

# I. SPECIFICATIONS

An asterisk next to a figure indicates the minimum guaranteed performance.

TRACK SYSTEM		4-track 2-channel stereo system
TAPE SPEED		7-1/2 ips (19 cm/sec.) $\pm 0.8\%$ 3-3/4 ips (9.5 cm/sec.) $\pm 1\%$
WOW AND FLUTTER		Less than 0.08% (*0.12%) RMS at 7-1/2 ips Less than 0.12% (*0.25%) RMS at 3-3/4 ips
TOTAL WOW AND FLUTTER		Less than 0.18% RMS at 7-1/2 ips (SCOTCH #175 tape, 3,000 Hz recording and playback)
FREQUENCY RESPONSE	S.R.T. TAPE	30 to 25,000 Hz $\pm 3$ dB at 7-1/2 ips 40 to 20,000 Hz $\pm 3$ dB at 3-3/4 ips
	REGULAR TAPE	30 to 23,000 Hz $\pm 3$ dB at 7-1/2 ips 40 to 18,000 Hz $\pm 3$ dB at 3-3/4 ips
TOTAL DISTORTION FACTOR		Less than 1.5% *Less than 2% at 1,000 Hz 0 VU recording *Less than 3% at 1,000 Hz 0 VU recording
OUTPUTS	LINE OUTPUT	1.228V (4 $\pm 1$ dB) at FWD mode, using a 250 Hz 0 VU pre-recorded tape 1.228V (4 $\pm 1.5$ dB) at REV mode, using a 250 Hz 0 VU pre-recorded tape
	DIN OUTPUT	610 mV ( $-2$ dB), using a 250 Hz 0 VU pre-recorded tape
INPUTS	MIC INPUT	More than 0.3 mV
	LINE INPUT	More than 60 mV
	DIN INPUT	More than 5 mV (Low) More than 60 mV (High)
RECORDING/PLAYBACK LEVEL		1.228V (4 $\pm 1.5$ dB) at 7-1/2 ips 1,000 Hz 0 VU recording
S/N RATIO		Better than 50 dB *Better than 50 dB at 7-1/2 ips *Better than 47 dB at 3-3/4 ips
TOTAL S/N RATIO		Better than 47 dB at 7-1/2 ips
CROSS TALK		Better than 45 dB *Better than 40 dB at 1,000 Hz, 3 VU recording
ERASE RATIO		Better than 70 dB
RECORDING BIAS FREQUENCY		102 kHz $\pm 5\%$
BIAS LEAK		Less than $-30$ VU
HIGH FREQUENCY DEVIATION	Between FWD channels	Within 3 dB
	Between REV channels	Within 4 dB
	Between FWD-REV	Within 3.5 dB
REVERSING TIME		2 to 3 seconds
RECORDING CAPACITY		45 min. stereo recording, using a 1,800 ft. tape at 7-1/2 ips
F.FWD AND RWD TIME		110/90 sec., using a 1,800 ft. tape at 50/60 Hz
MOTORS	CAPSTAN MOTOR	2 speed Hysteresis Synchronous Motor Type: HM2-16MC (winterized) 4-8 pole Revolutions: 1,500/1,800 r.p.m. at 50/60 Hz 750/900 r.p.m. at 50/60 Hz
	REEL MOTOR	Two 6-pole eddy current outer rotor motor Type: 24XO-MR Revolutions: 930/1,120 r.p.m. at 50/60 Hz
HEADS	COMBO RECORDING/ERASE HEAD	Type: RE4-6 GX Head Gap: 3.5 to 5.5 microns (REC) 0.2 mm W Gap (Erase) Impedance: 1,400 $\Omega$ $\pm 25\%$ at 100 kHz (REC) 130 $\Omega$ $\pm 7\%$ at 100 kHz (Erase) D.C. Resistance: 5.5 $\Omega$ (REC) 2.3 $\Omega$ (Erase)
	PLAYBACK HEAD	Type: P4-202 GX Head Gap: 1.2 to 2.2 microns Impedance: 1,400 $\Omega$ at 1,000 Hz D.C. Resistance: 268 $\Omega$

TRANSISTORS	2SC711(D) (E) (F) . . . 14 2SD360(D) . . . 1	2SC1312(G) (H) . . . 14
DIODES	1N34A . . . 4 10D05 . . . 4 10D2 . . . 1	1S2473VE . . . 4 10D1 . . . 1 WG713 . . . 1
ZENER DIODES	WZ240 . . . 1	YZ088 . . . 2
POWER SUPPLY	100 to 240V A.C. 50/60 Hz for Universal and WG models 120V A.C. 60 Hz for CSA models 220V A.C. 50 Hz for CEE models	
POWER CONSUMPTION	100W max.	
DIMENSIONS	371(H) x 368(W) x 227(D) mm (14.6" x 14.5" x 8.9")	
WEIGHT	15.4 kg (33.9 lbs.)	

**NOTE:** Specifications subject to change without notice.

## II. MEASURING METHOD

### 1. TAPE SPEED DEVIATION

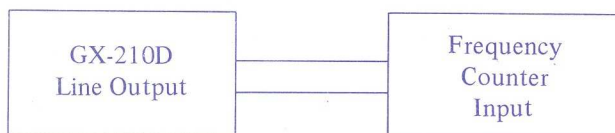

Fig. 1

As shown in Fig. 1, connect a Frequency Counter to the Line Output. Playback a 1,000 Hz pre-recorded test tape. Take a frequency counter reading at the beginning, middle, and end of tape winding during playback. The maximum value of these respective readings will represent tape speed deviation.

### 2. WOW AND FLUTTER

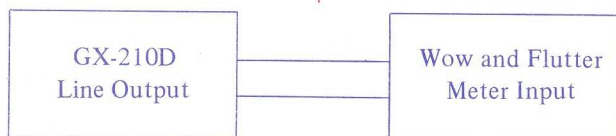

Fig. 2

#### Method A

As shown in Fig. 2, connect the Line output to the Input of a Wow and Flutter Meter. Playback a 3,000 Hz pre-recorded test tape and take a wow and flutter meter reading at the beginning, middle, and end of tape winding. The maximum value of these respective readings will represent the wow and flutter.

#### Method B

Supply a 3,000 Hz sine wave signal from an Audio Frequency Oscillator and make a recording on a blank tape at the beginning, middle, and end of tape winding. Rewind and playback the resultant signals. Measure wow and flutter with a Wow and Flutter Meter. (The wow and flutter value of Method B will be close to twice that of Method A.)

### 3. FREQUENCY RESPONSE

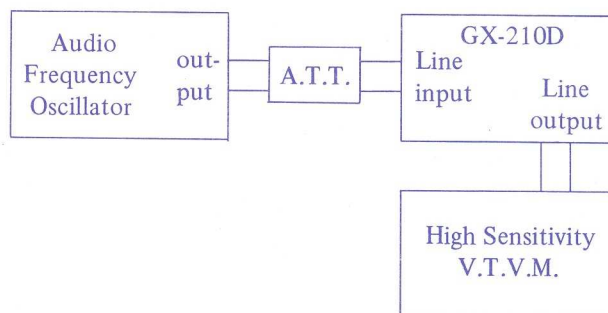

Fig. 3

For measuring frequency response, connect instruments as shown in Fig. 3 and proceed as follows:

- 1) Supply a 2,000 Hz sine wave signal to the Line input from an Audio Frequency Oscillator through an Attenuator.
- 2) Set tape deck to recording mode and turn recording level control volume to maximum. Adjust attenuator to obtain a +4 dB V.T.V.M. reading.
- 3) Under conditions described in 2) above, re-adjust attenuator so that the Line output is -16 dB, and record 30 to 23,000 Hz at 7-1/2 ips spot frequencies.
- 4) Rewind the tape and playback from the beginning. Take V.T.V.M. spot frequency readings and plot values on a graph.

NOTE: When measuring frequency response, new tape should be used.

### 4. SIGNAL TO NOISE RATIO

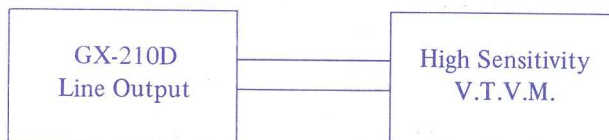

Fig. 4

As shown in Fig. 4, connect a High Sensitivity V.T.V.M. to the Line output. Playback a 250 Hz "0" VU pre-recorded test tape and measure the output. Then remove the tape and measure the noise level under the same condition. Convert each of the measured values into decibels.

## 5. TOTAL HARMONIC DISTORTION FACTOR

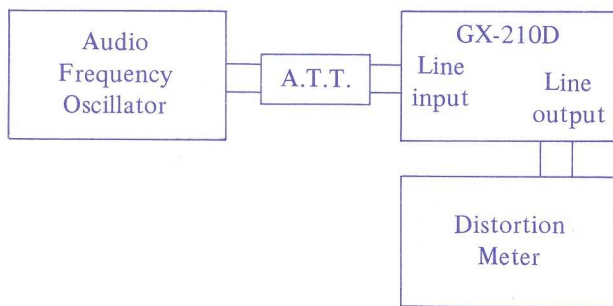

Fig. 5

Connect the measuring instruments as shown in Fig. 5 and record a 1,000 Hz sine wave signal at "0" VU. Playback the resultant signal and measure the overall distortion factor. Measure the noise level of the tape recorder without the tape. Connect the audio frequency oscillator directly to the distortion meter for measurement of the distortion factor of the oscillator. The required distortion factor can be obtained from the results of the above measurement by the following formula:

$$d_0 = d - d_1 - d_2$$

where,  $d_0$  = Required distortion factor  
 $d$  = Overall distortion factor  
 $d_1$  = Noise Level  
 $d_2$  = Distortion factor of the oscillator

NOTE: When measuring the distortion factor, new tape should be used.

## 6. CROSS TALK (Cross talk between the channels)

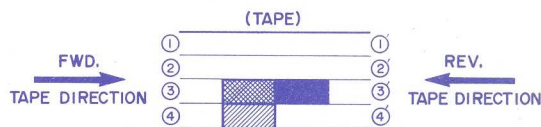

Fig. 6

As shown in Fig. 6, first record a 1,000 Hz sine wave signal on Track No. 3 at +3 VU level. Next, record under a non-input condition. Then, playback the tape on Tracks No. 3 and 4 (reversed condition of tape) through the B.P.F. (band pass filter, Sensitivity ... 1:1) and obtain a ratio between the two from the following formula:

$$C = 20 \log \frac{E_0}{E_2 - E_1} \text{ (dB)}$$

where,  $C$  = Desired cross talk ratio (dB)

$E_0$  = 1,000 Hz signal output level

$E_2$  = 1,000 Hz cross talk level

$E_1$  = Non-input signal recorded level



## 7. ERASE RATIO

As shown in Fig. 4, connect a High Sensitivity V.T.V.M. to the Line output. Playback a virgin tape and take a V.T.V.M. reading of the output level. Next, record a 1,000 Hz sine wave signal at +3 VU, then playback this recorded signal and take a V.T.V.M. reading of the output level. Next, using this pre-recorded tape, record under a non-input condition and take a reading of the noise level output of the erased signal and obtain a ratio between the two from the following formula:

$$E_r = 20 \log \frac{E_0}{E_2 - E_1} \text{ (dB)}$$

where,  $E_r$  = Desired erase ratio (dB)

$E_0$  = 1,000 Hz signal output level

$E_2$  = Non-input signal recorded level

$E_1$  = Virgin tape noise output level

### III. DISMANTLING OF UNIT

In case of trouble, etc. necessitating disassembly, please disassemble in the order shown in photographs. Reassemble in reverse order.

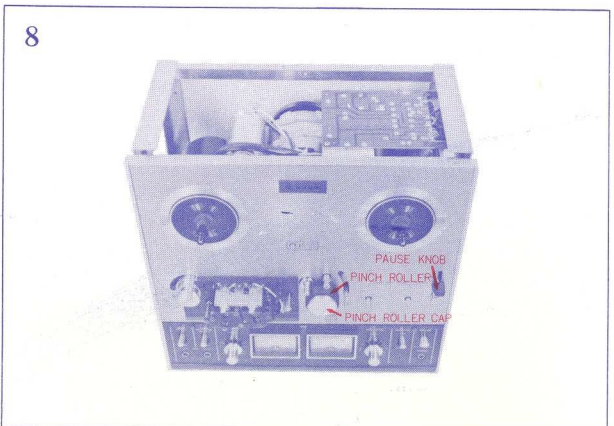
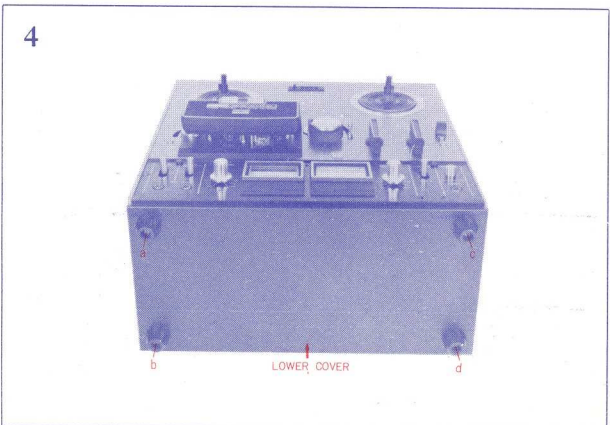
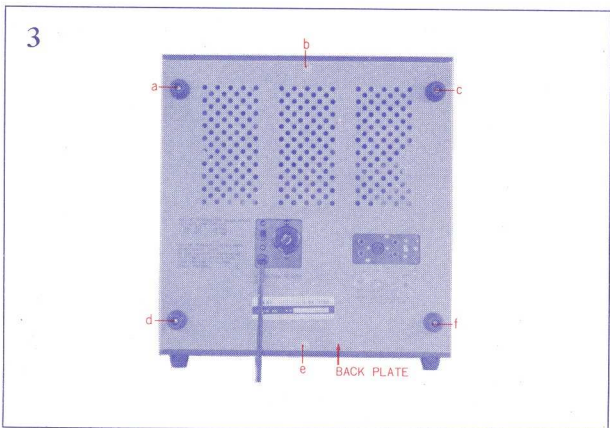
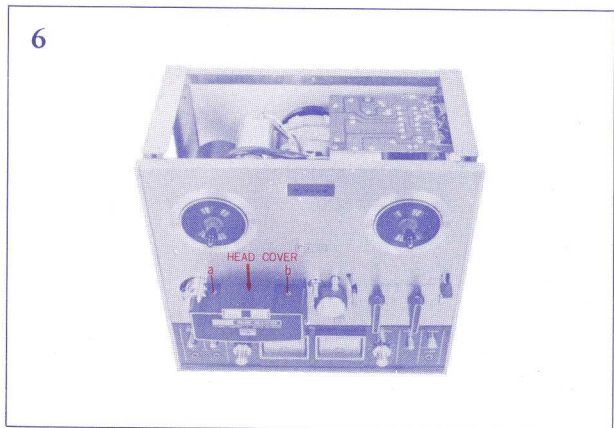



9

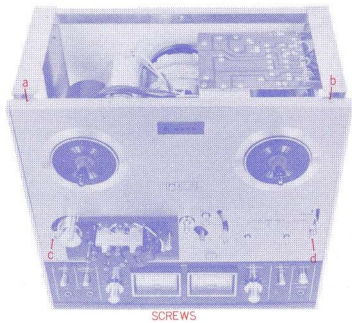

SCREWS

13

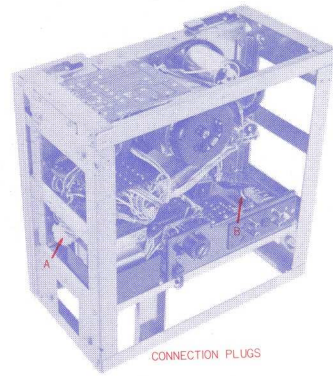

CONNECTION PLUGS

10

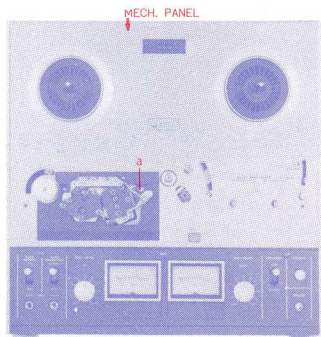

14

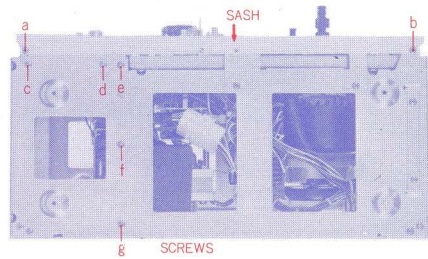

SCREWS

11



AMPLIFIER KNOBS

15

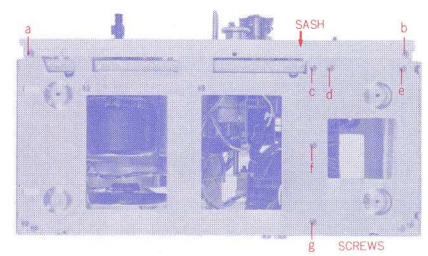

SCREWS

12

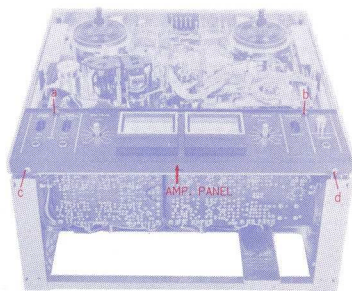

AMP. PANEL

16

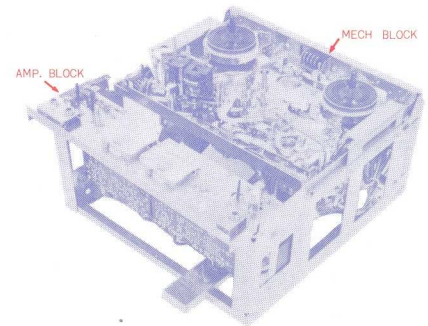

# IV. SYSTEM CONTROL CIRCUIT OPERATION

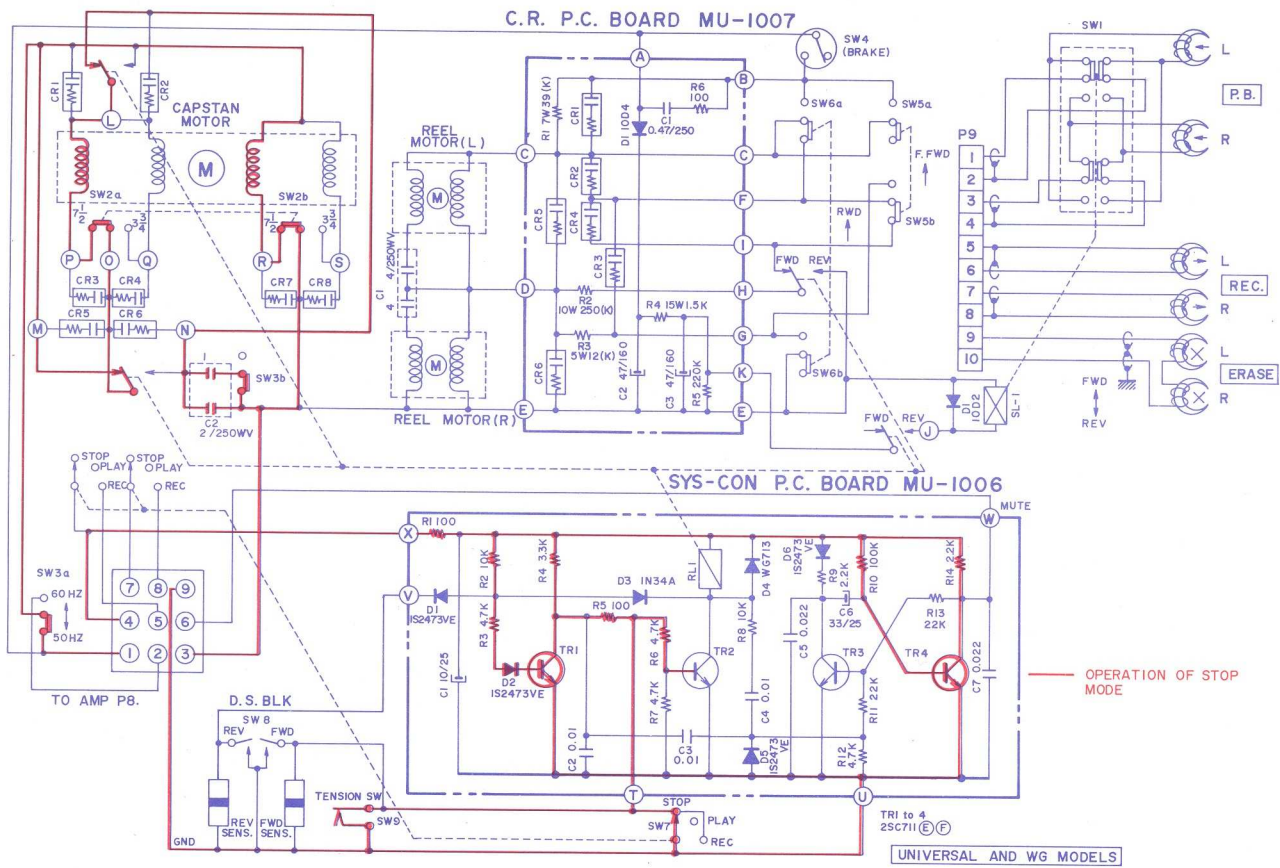

SCHMATIC 1

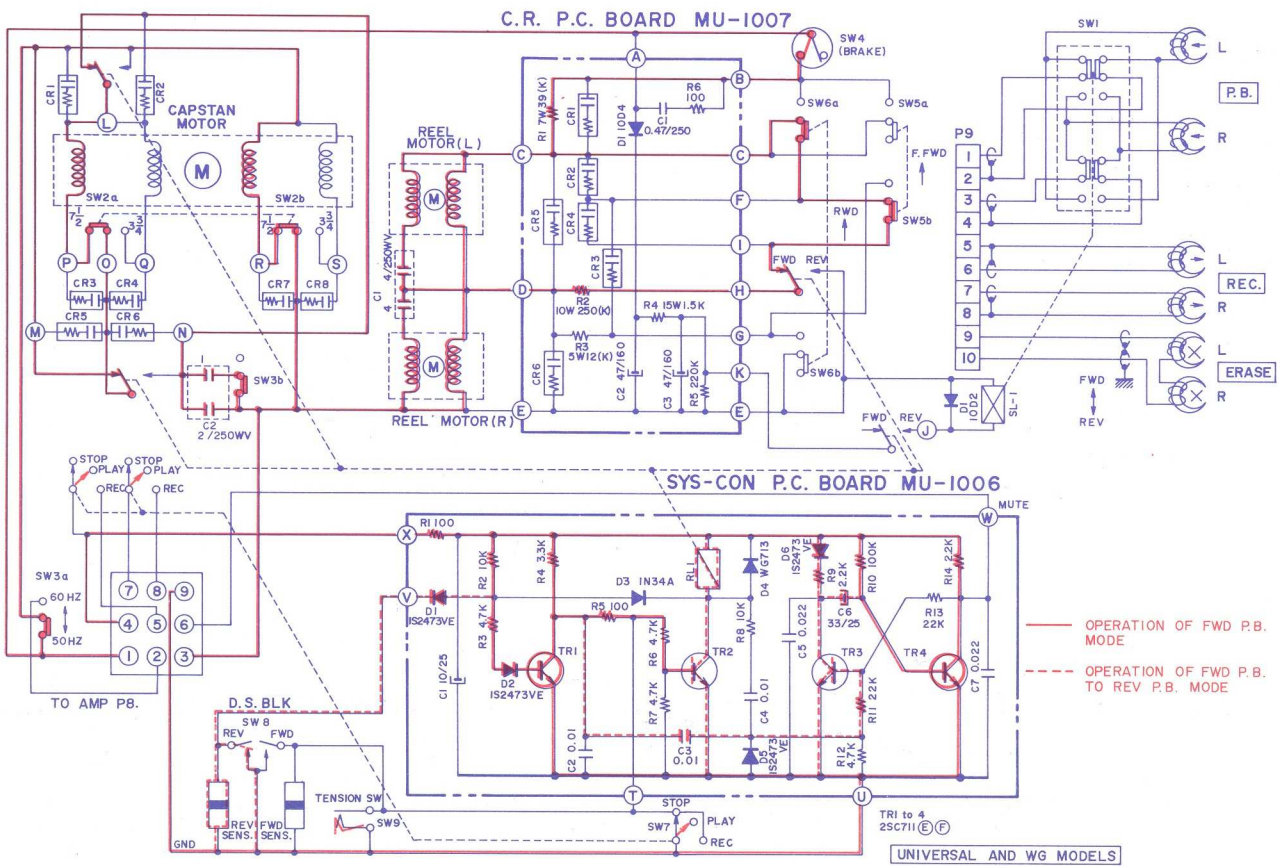

SCHMATIC 2

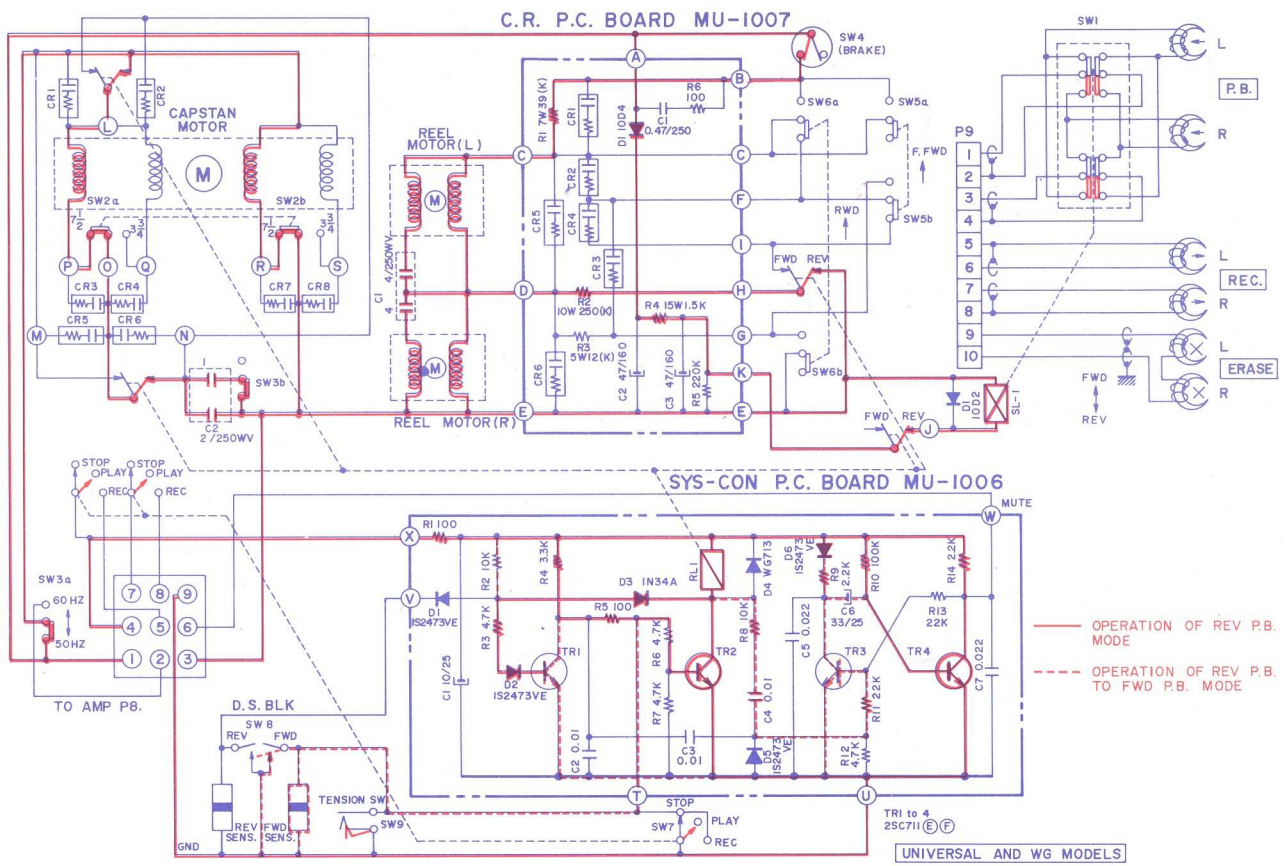

SCHMATIC 3

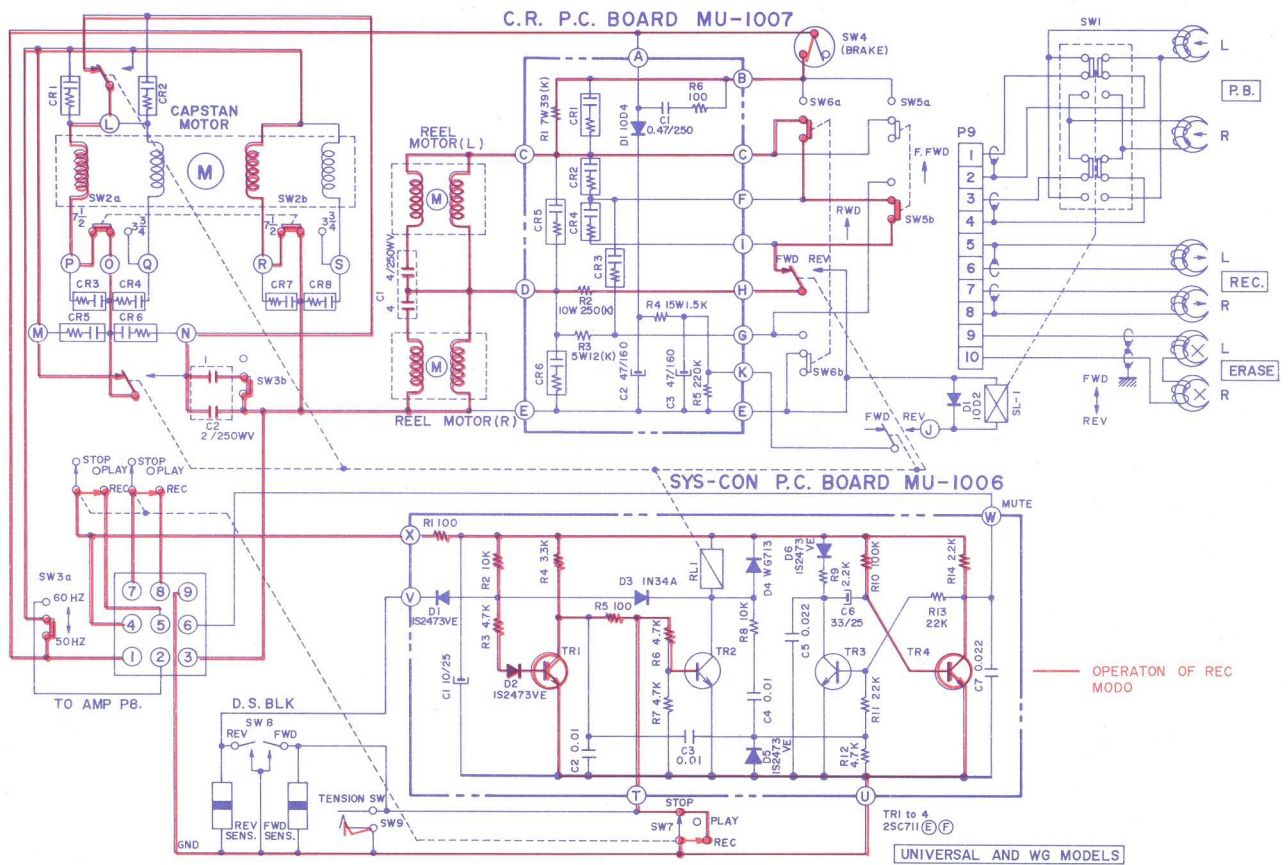

SCHMATIC 4

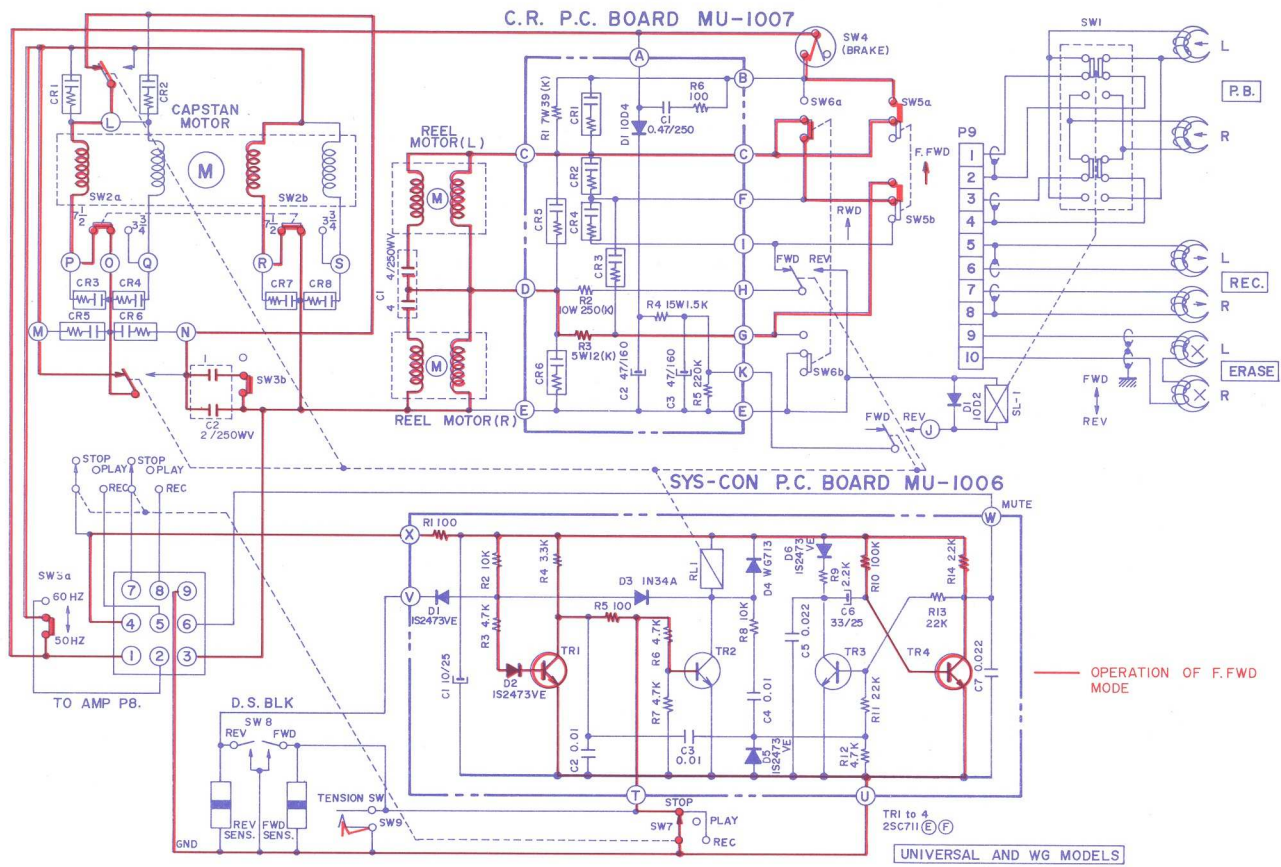

SCHMATIC 5

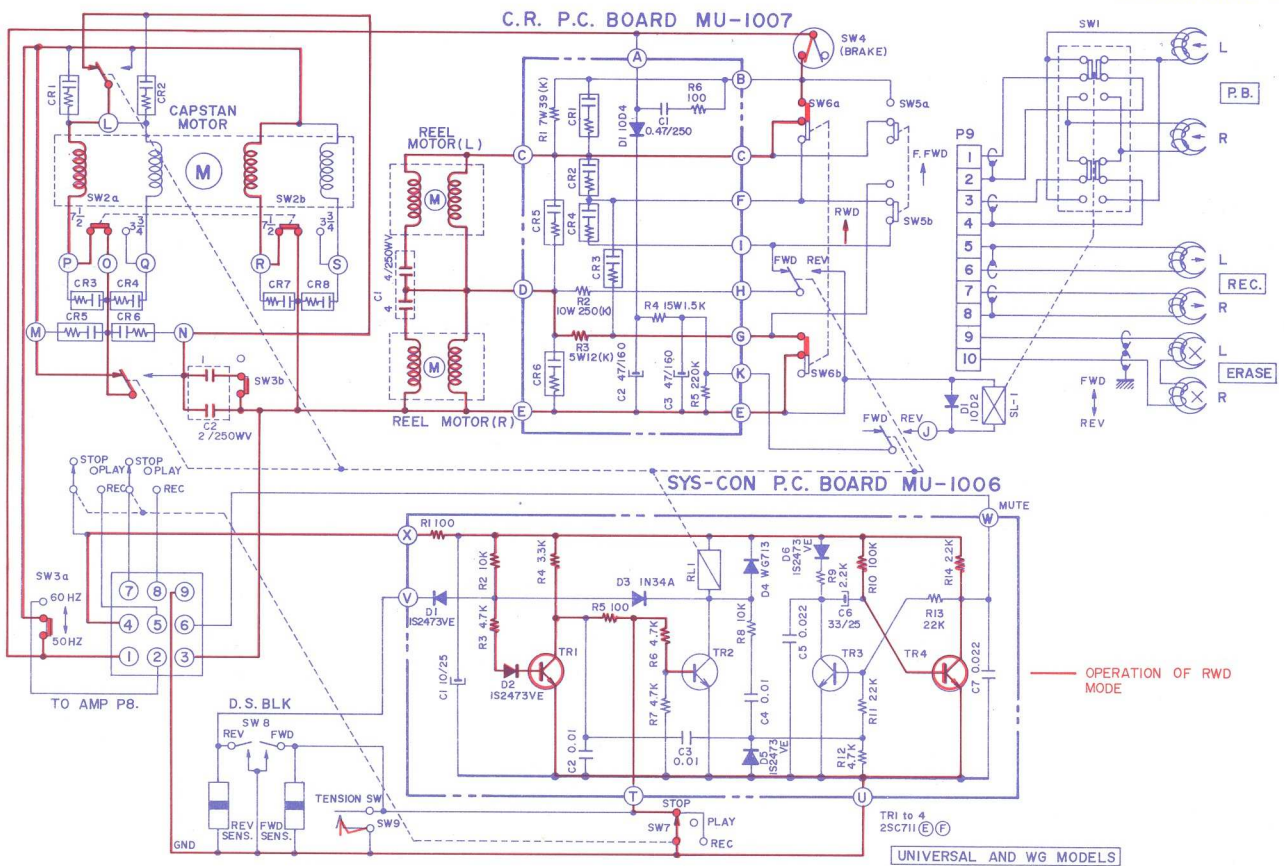

SCHMATIC 6

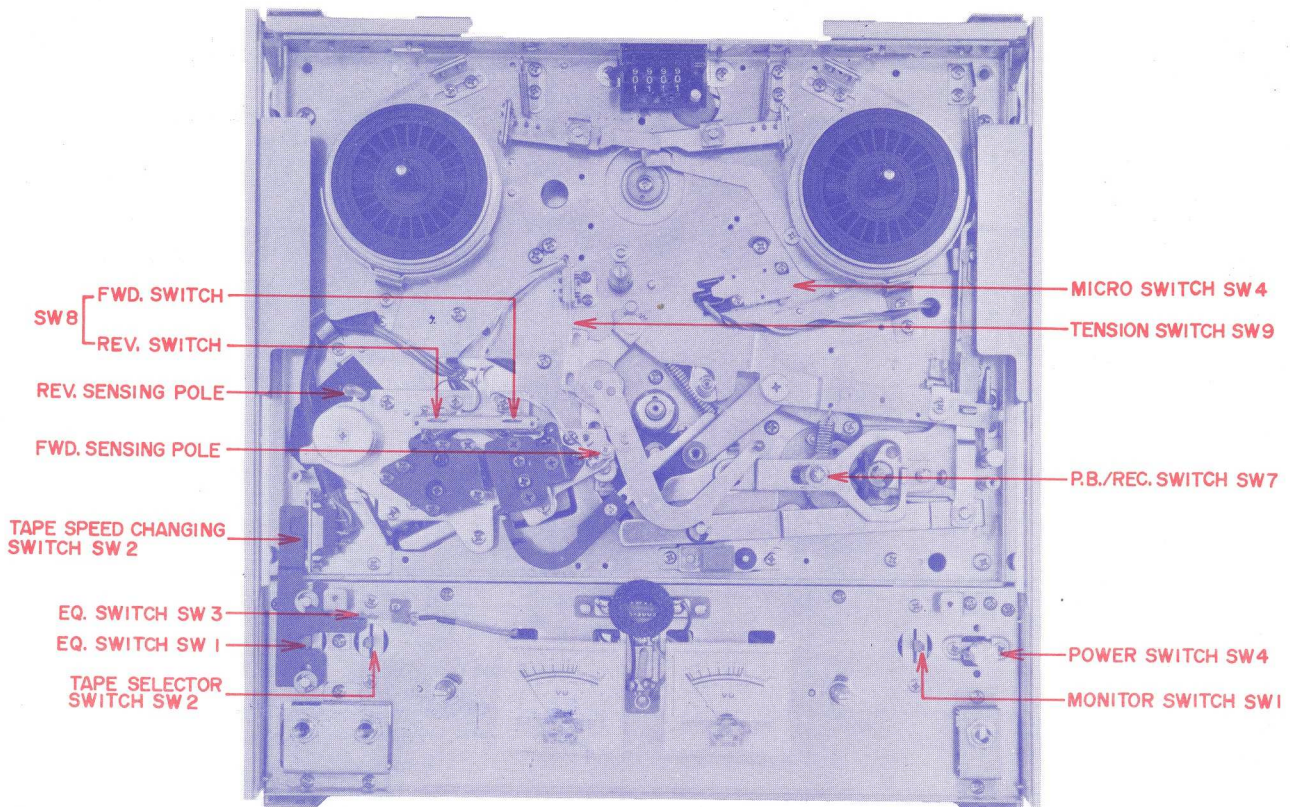

Fig. 7

## 1. STOP MODE (Refer to Schematic Diagram-1)

At Stop Mode, the various System Control (hereinafter referred to as SYSCON) transistors are maintained as follows: TR1(ON), TR2(OFF), TR3(OFF), and TR4(ON). Accordingly, the reverse relay connected to the collector of TR2 is OFF, and capstan motor revolutions are in forward direction. Also as TR4 is ON and TR4 collector voltage is roughly zero and thus Diode D1 (Playback Amp. P.C. Board) connected to the collector of TR4 is turned OFF, the playback Amp. Mute Circuit is also turned OFF. Both the supply and take-up reel motor are equipped with a Micro Switch SW4 which is activated to OFF and ON by the operation of the brake lever, and which at Stop Mode are turned OFF. Consequently, no voltage is supplied to either reel motor (both reel motors are connected in series).

When at Stop Mode, switching by means of P.B./REC Switch SW-7 does not take place because the base of SYSCON TR2 is grounded and maintained at OFF condition.

That is to say, capstan motor revolutions will not reverse even when a REV Button is depressed. When the tension lever is raised, Tension Switch SW-9 is turned OFF. Thus, when no tape is loaded, this switch is ON.

Also, because Tension Switch SW-9 is installed in parallel with P.B./REC Switch SW-7, when SW-7 is at Stop Mode, if a tape is loaded, but not threaded through the Tension Lever and playback is effected,

reverse mode cannot be effected when a Reverse Button is depressed. And, of course, reverse mode will not be effected when the sensing foil passes the sensing poles.

## 2. FORWARD PLAYBACK MODE (Refer to Schematic Diagram-2)

When the P.B./REC Switch is at PLAY position, the various SYSCON transistors are maintained as follows: TR1(ON), TR2(OFF), TR3(OFF), and TR4(ON), i.e. functionally, the same as at stop mode. The difference is that the base of TR2 which was grounded by P.B./REC Switch SW-7 is now open. That is to say, when TR1 is turned OFF and TR1 collector voltage increases, bias is supplied to TR2, and TR2 is turned ON. Accordingly, while TR1 is (ON) and TR2(OFF) (FWD Playback Mode), capstan motor revolutions are in forward direction. Also Micro SW-4 is ON, and voltage is supplied to both reel motors.

At FWD Playback mode, an R2 (10W, 250Ω) resistor is in parallel with left reel motor winding. That is to say, the left reel motor resistance differs from the right reel motor resistance due to the R2 (10W, 250Ω) resistor which is parallel with the left reel motor as shown in Fig. 8.

In short, the voltage supplied to the left reel motor is low and FWD. Playback mode is maintained.

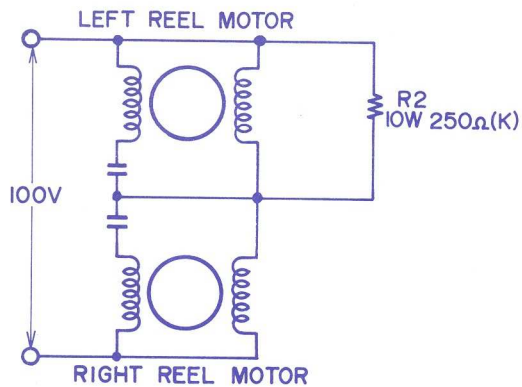

Fig. 8

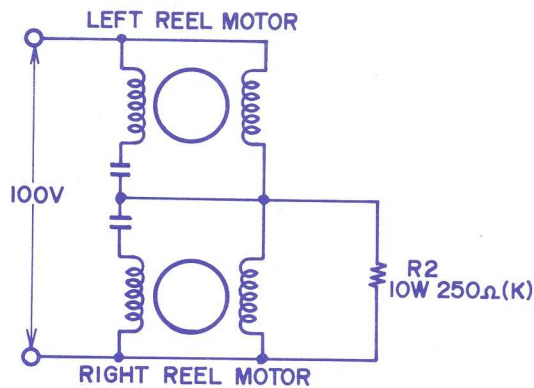

Fig. 9

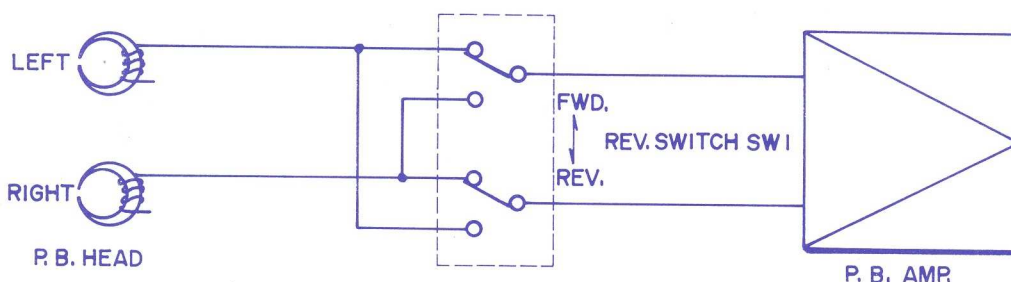

Fig. 10

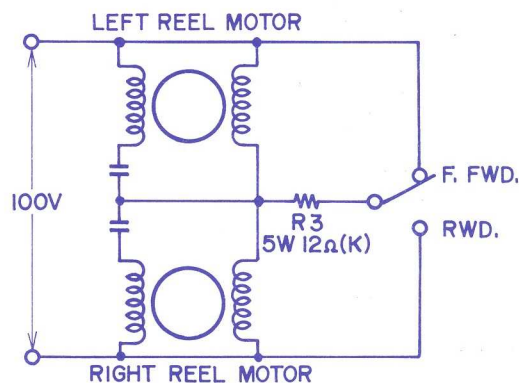
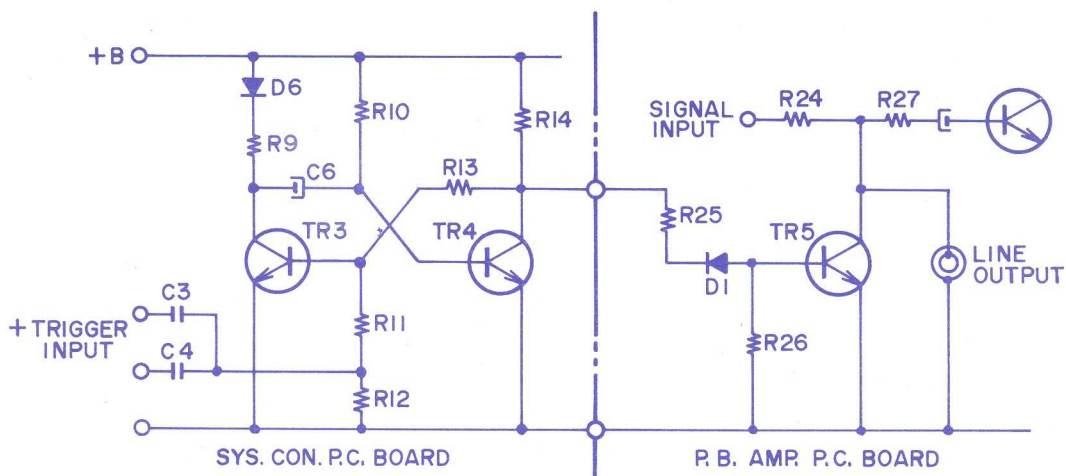

Fig. 11

### 3. FROM FWD TO REV PLAYBACK, AND REV PLAYBACK MODE (Refer to Schematic Diagrams-2, 3)

When the sensing tape passes the reverse sensing poles or when the Reverse Button is depressed, the base of TR1 is biased at zero electrical potential and TR1 is instantly turned OFF, TR1 collector voltage increases and bias is applied to the base of TR2, TR2 is turned ON, and Reverse Relay RL-1 is turned ON. In this TR1 and TR2 circuit, TR1 is maintained at OFF and TR2 at ON by means of Diode D3 (1N34A). (Refer to Schematic Diagram-3) By means of the reverse relay function, current flows from the reverse direction to the capstan motor sub coil, and reverse revolutions begin. Also, at FWD playback time, Resistor R2 (10W, 250Ω) connected in parallel with the left reel motor becomes parallel with the right reel motor. (Refer to Fig. 9)

At this condition, reverse playback begins and is maintained, and the capstan motor revolutions begin reversing from forward direction. For normalized and stable revolutions, flywheel inertia at time of forward revolutions and flywheel mass when reverse revolutions begin is applied so that stabilized tape speed is not immediate. For this reason, the signal output circuit must be muted until the capstan motor revolutions have been stabilized. (Refer to MUTING CIRCUIT OPERATION explanation) Solenoid Plunger SL1 also functions to shift down Reverse Switch SW-1 and the P.B. Head. In other words, P.B. Head left and right channels are reversed by means of SW-1 as shown in Fig. 10.



SCHEMATIC 7

#### 4. FROM REVERSE TO FORWARD PLAYBACK (Refer to Schematic Diagram-3)

When the sensing tape passes the FWD sensing pole or when the FWD Button is depressed and the base of TR2 becomes biased at zero electrical potential, TR2 is instantly turned OFF, and reverse relay RL-1 is also turned OFF.

Diode D3 (1N34A) is also inverse biased, TR1 base current passes R2 (10 k $\Omega$ ), R3 (4.7 k $\Omega$ ), and D2 (1S2473VE) and is biased, and TR1 is turned ON and maintained.

Consequently, reverse relay RL1 returns to its original condition (FWD P.B.) and FWD playback mode is effected.

Refer to MUTING CIRCUIT OPERATION for mute function during change from REV to FWD playback.

#### 5. RECORDING MODE

SYSCON operation at recording time is exactly the same as Stop mode.

#### 6. FAST FORWARD AND REWIND MODE (Refer to Schematic Diagrams-5, 6)

In this case, SYSCON operation is also exactly the same as Stop mode. However, the voltage supply to both reel motors are as shown in Fig. 11.

#### 7. MUTING CIRCUIT OPERATION (Refer to Schematic Diagrams 2, 3, and 7)

As shown in Schematic Diagram-7, the muting circuit is made up of an electronic switch from transistor TR5 and a one-shot multi-vibrator comprised of TR3 and TR4. When stabilization is attained, TR3 of the one-shot multi-vibrator is turned OFF, and TR4 turned ON. Accordingly, the electrical potential of TR4 collector is lowered, Zener Diode D1 is biased in reverse direction, and TR5 assumes an OFF condition. If Button SW-8 is now depressed for FWD to REV playback, or REV to FWD playback, a charge current flows to condenser C3 or C4. Thus the base of TR3 is biased (this becomes the trigger signal), the one-shot multi vibrator comprised of TR3 and TR4 is inverted, and after a certain period of time (2 to 3 seconds) again returns to its stabilized condition.

Further, while this one-shot multi-vibrator is inverted, (while TR4 is OFF) because TR4 collector voltage is high, the voltage exceeding the zener point of Zener Diode D1 is applied to the cathode of D1 and D1 assumes a lead-through condition. Thus, electronic switch transistor TR5 is turned ON, and the signal is muted (the internal resistance TR5 at lead through time is extremely low).

# V. MECHANISM ADJUSTMENTS

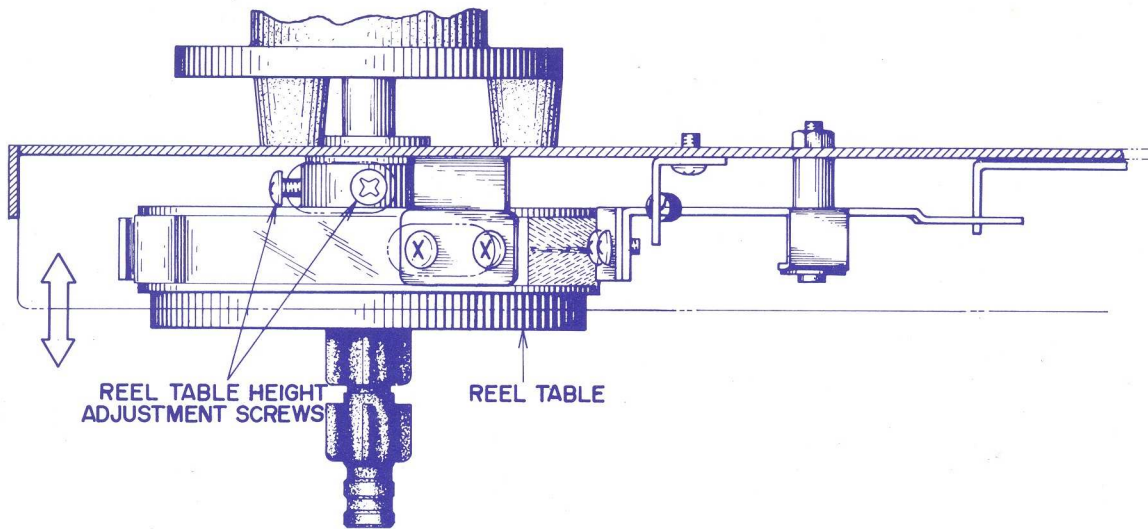

Fig. 12

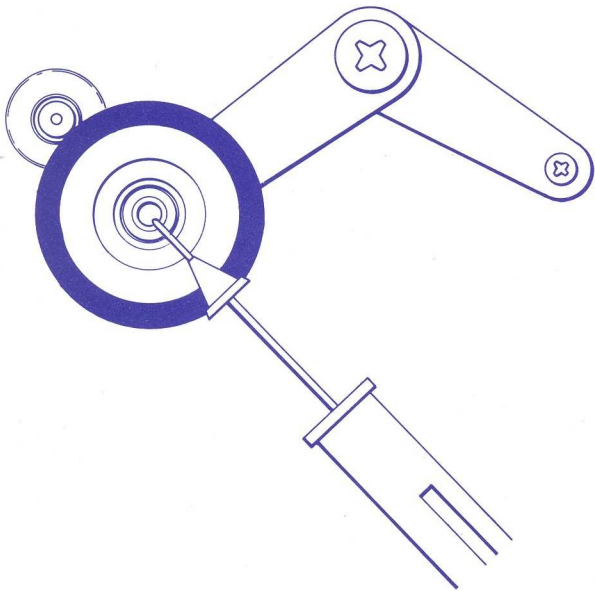

Fig. 13

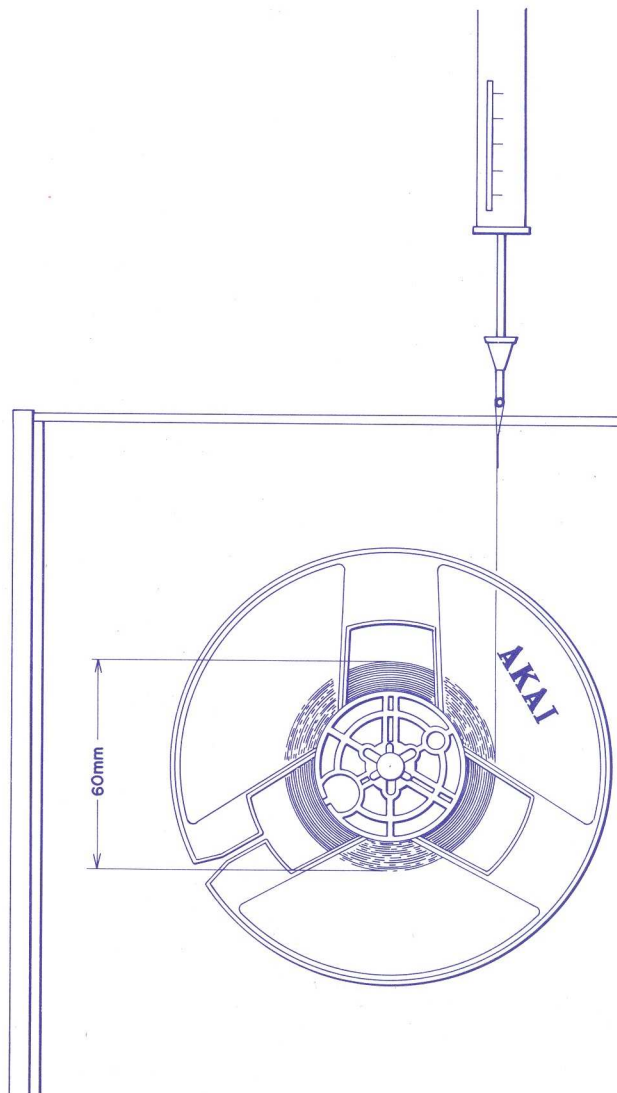

Fig. 14



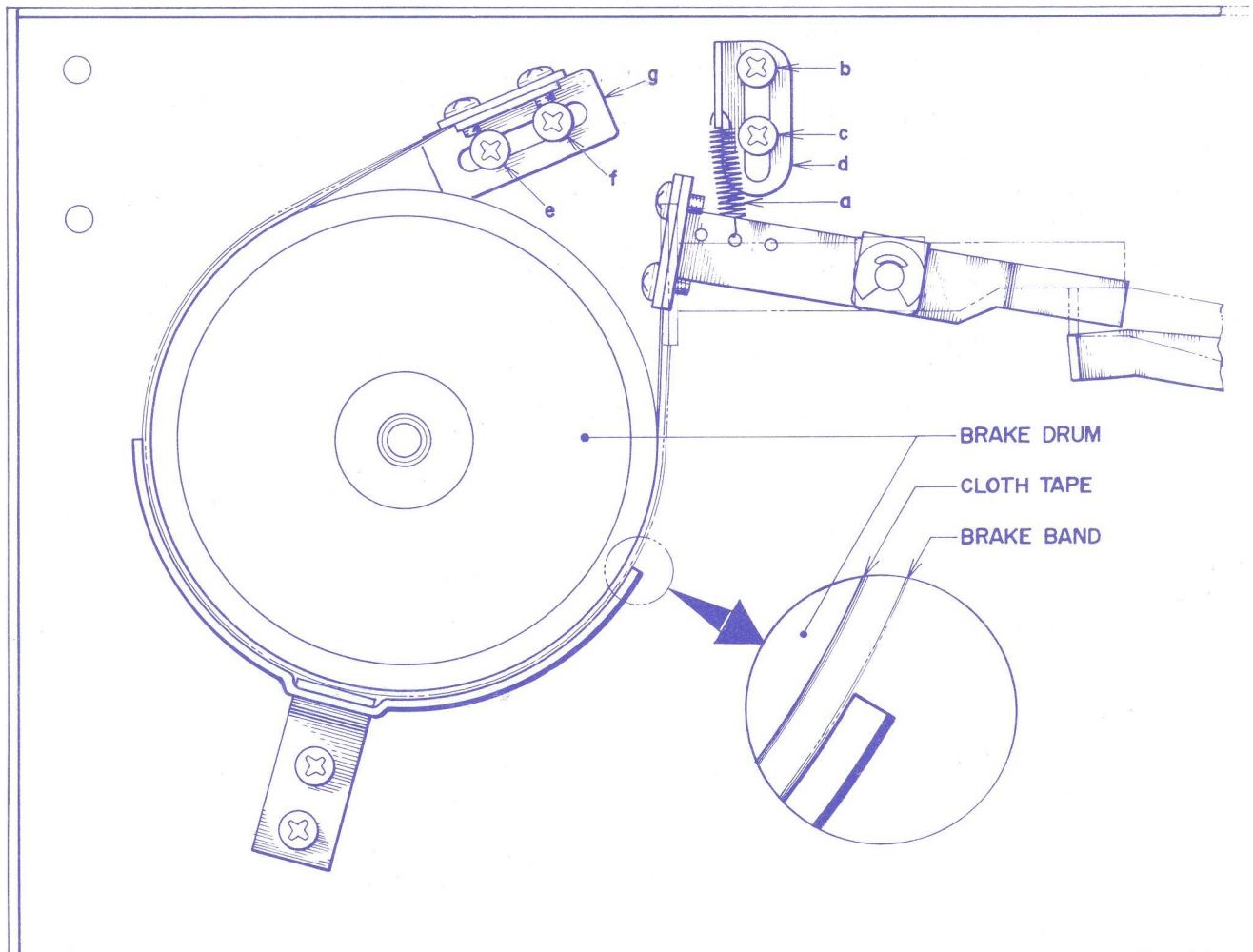

Fig. 15

### 1. REEL TABLE HEIGHT ADJUSTMENT

As shown in Fig. 12, loosen reel table height adjustment screws, and adjust reel table height by moving table in direction of arrow and positioning so that the tape winds in the center of the reel.

### 2. PINCH WHEEL PRESSURE MEASURING METHOD

Measure pinch wheel pressure with a tension gauge as shown in Fig. 13. Read the value on the tension gauge as soon as the pinch wheel separates from the tape and tape travel stops. Ideal pinch wheel pressure is 1.8 kg.

### 3. BRAKE TENSION ADJUSTMENT

- 1) As shown in Fig. 14, use a 60 mm diameter tape wound on a 5" reel and measure the brake tension with a tension gauge. Ideal brake tension is from 300 to 370 grams.
- 2) Brake tension adjustment can be made as follows: (Refer to Fig. 15)
  - a) Change position of suspended spring (a).
  - b) Loosen screws (b) and (c) and adjust the vertical position of spring suspension metal (d).
  - c) Loosen screws (e) and (f) and adjust the horizontal position of brake band suspension metal (g).
  - d) Only the left side is shown in Fig. 15, but the right side must be adjusted in the same way.

NOTE: In making brake tension adjustment, at all modes except stop mode, confirm that the brake band completely separates from the cloth tape on the brake drum. (Refer to Fig. 15)

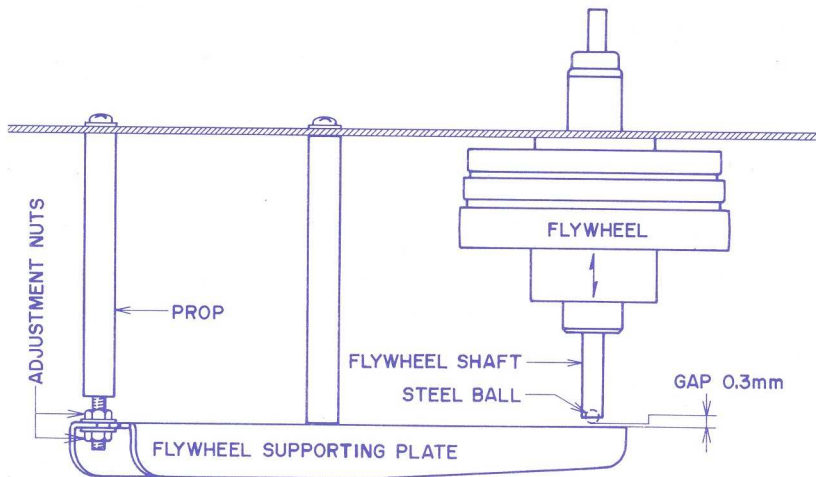

Fig. 16

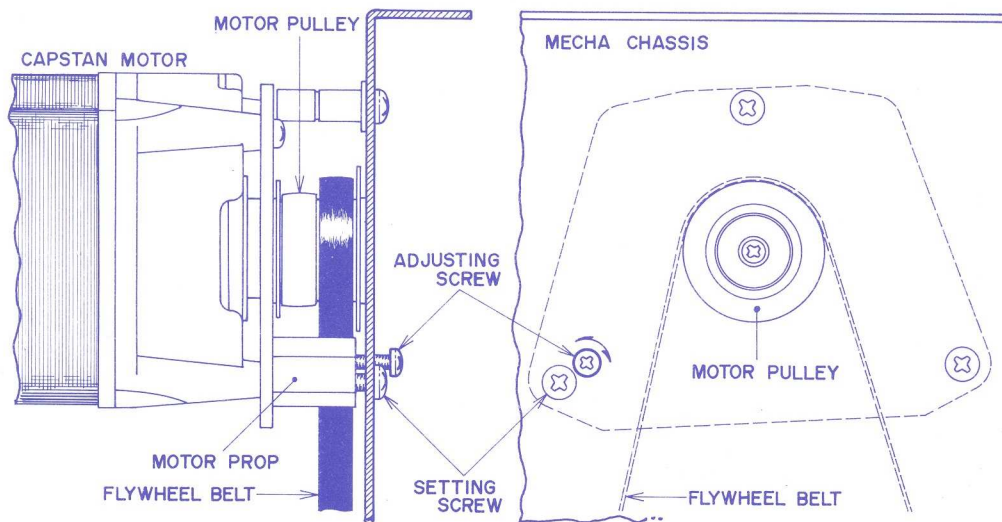

Fig. 17

#### 4. LEFT AND RIGHT REEL MOTOR TENSION AT VARIOUS OPERATING MODES

Mode \ Reel Motor	Left Reel Motor	Right Reel Motor
FWD P.B.	60g	180g
REV P.B.	180g	60g
F.FWD	10g	450g
RWD	450g	10g

Chart 1

#### 5. FLYWHEEL LOOSE PLAY ADJUSTMENT

Turn the adjustment nuts to obtain a 0.3 mm gap between the steel ball and flywheel supporting plate when the flywheel is moved in the direction of the arrow as shown in Fig. 16.

#### 6. FLYWHEEL BELT POSITION ADJUSTMENT

- 1) With capstan motor revolutions operating at Rev. mode, loosen setting screw and turn flywheel belt position adjustment screw until the flywheel belt comes to the center of the motor pulley. (Refer to Fig. 17)
- 2) Tighten setting screw to maintain center positioning of flywheel belt at Rev. mode.
- 3) Confirm that the flywheel belt runs on the center of the motor pulley at Fwd. mode also.

## VI. HEAD ADJUSTMENTS

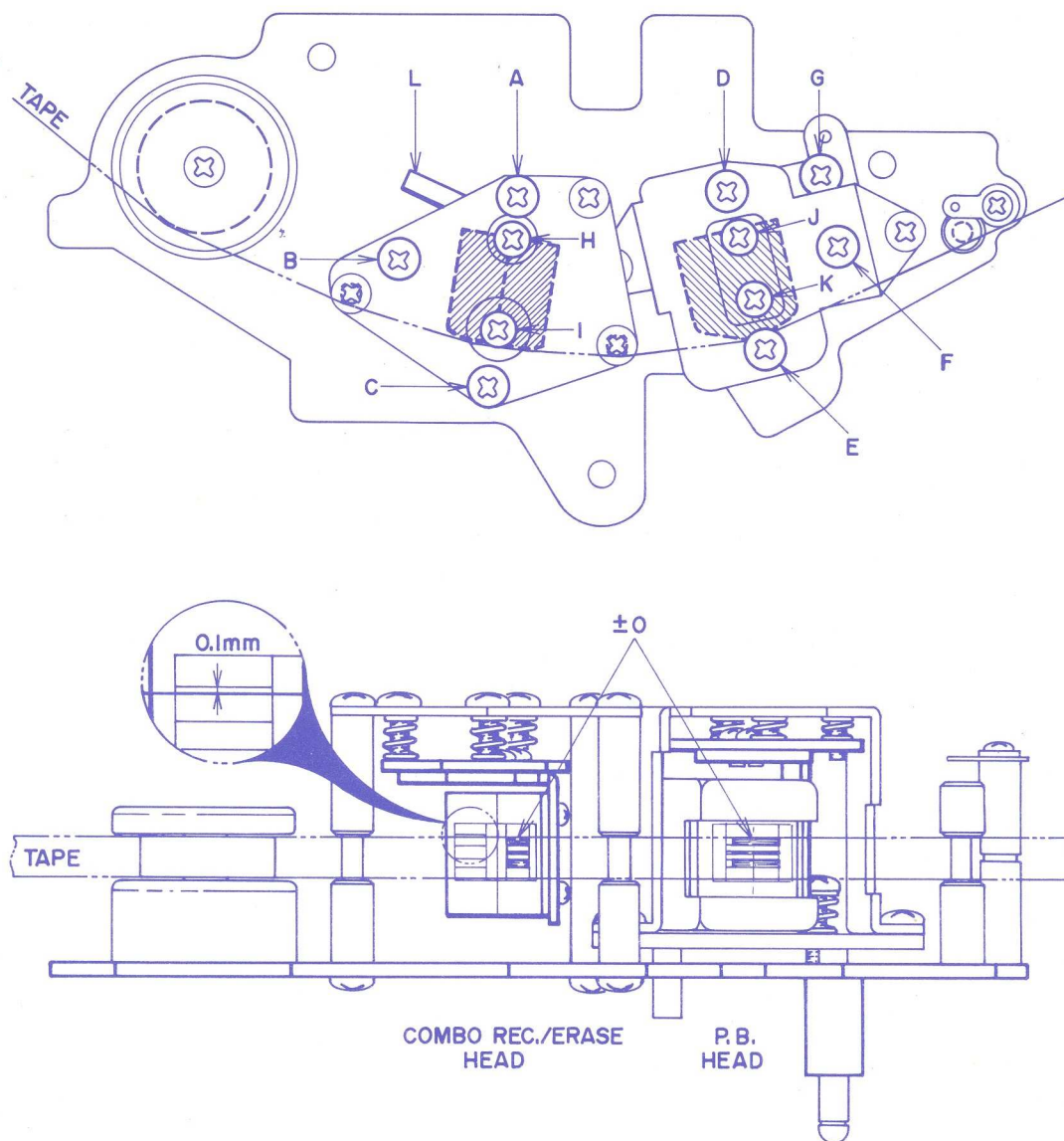

Fig. 18

### 1. HEAD HEIGHT ADJUSTMENT

#### 1) COMBO Head

At Playback mode adjust COMBO head height by turning screws (A) (B) and (C) shown in Fig. 18 to left and right until the upper edge of the tape is the same height as the upper edge of the left channel recording head core.

#### 2) Playback Head

a) At Forward Playback mode, adjust playback head height by turning screws (D) (E) and (F) shown in Fig. 18 to left and right until the upper edge of the tape is the same height as the upper edge of the left channel playback head core.

b) At Reverse Playback mode, adjust playback head height by turning screw (G) shown in Fig. 18 to left and right until the lower edge of the tape is the same height as the lower edge of the right channel playback head core.

### 2. HEAD AZIMUTH ALIGNMENT ADJUSTMENT

#### 1) Playback Head

- a) Connect a high sensitivity V.T.V.M. to the line output terminals.
- b) Set the Tape Speed Switch to 7-1/2 ips. (19 cm/sec.), and set the Monitor Switch to TAPE position.
- c) Playback an 8,000 Hz 3-3/4 ips. recorded Ampex Alignment test tape.
- d) At Forward Playback mode, turn Azimuth Alignment Screw (F) shown in Fig. 18 to obtain maximum line output level on both channels.
- e) After the adjustment in Item d) above has been completed, loosen screws (J) and (K) shown in Fig. 18 and move the head gap side of the playback head to left and right. When tension is applied to the supply reel side and

---

the line output level of both channels do not fluctuate, (maximum allowable fluctuation within  $+0.5/-0$  dB) fix screws (J) and (K) to maintain this condition.

- f) At reverse playback mode, make the same adjustment as outlined above until the line output level of both channels do not fluctuate.

## 2) COMBO Head

- a) Connect an audio frequency oscillator to the line input terminals, and connect a high sensitivity V.T.V.M. to the line output terminals and load a blank tape.
- b) Set the Tape Speed Switch to 7-1/2 ips. (19 cm/sec.) and set the monitor switch to TAPE position.
- c) Record a 16,000 Hz audio frequency at  $-10$  dB recording level.
- d) At recording mode, turn Azimuth Alignment Adjustment Screw (B) shown in Fig. 18 to left and right until the line output level of both channels is maximum and does not fluctuate.
- e) After completing adjustment in Item d) above, adjust gap side of recording head by moving installation angle (L) shown in Fig. 18 to left and right until the line output level of both channels do not fluctuate (maximum allowable fluctuation within  $+0.5/-0$  dB) when tension is applied to the supply reel side.

3. To obtain best results, repeat adjustments outlined in paragraphs 1 and 2 above 2 or 3 times. New blank tape should be used when making these adjustments.

## VII. AMPLIFIER ADJUSTMENTS

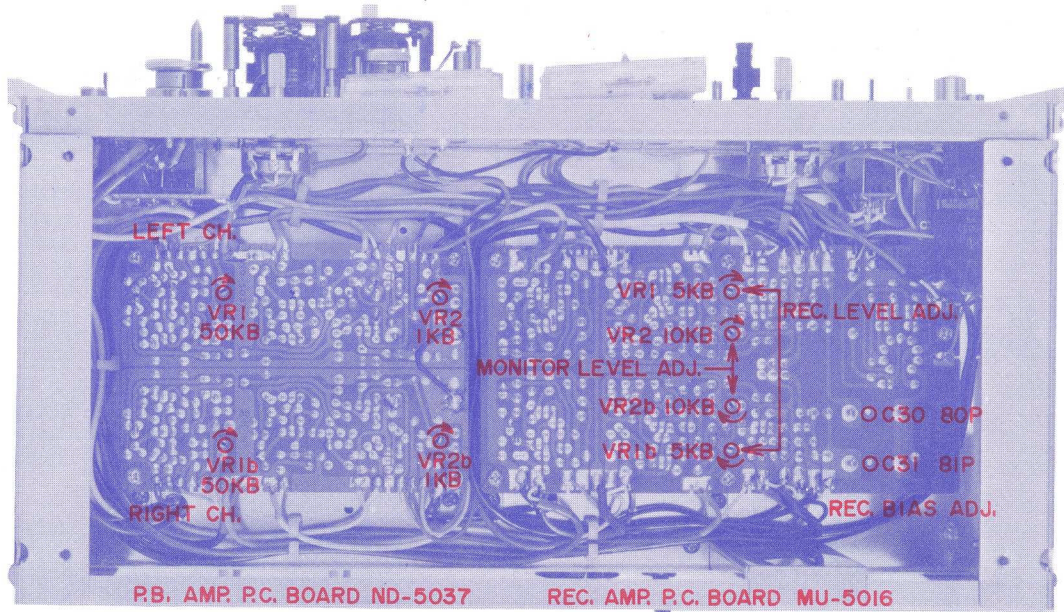

Fig. 19

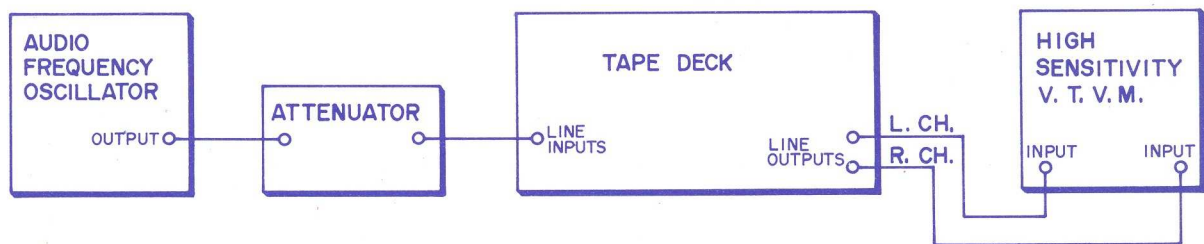

Fig. 20

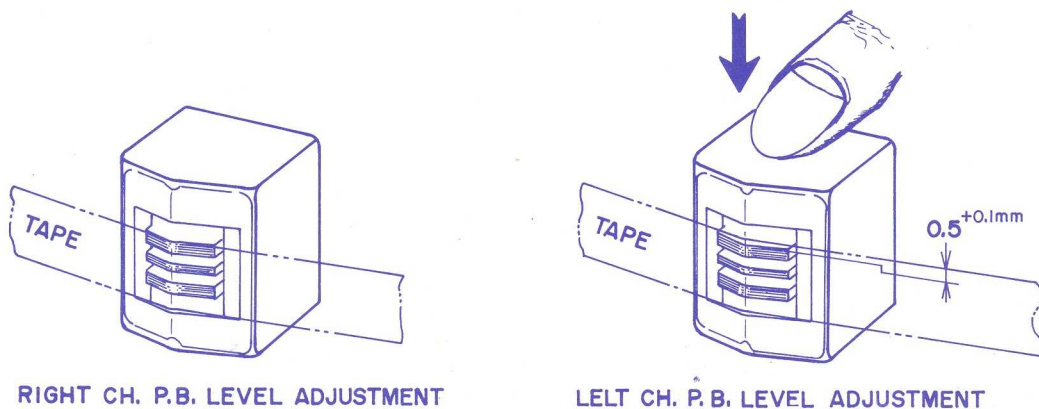

Fig. 21

Connect the various measuring instruments as shown in Fig. 20.

### 1. PLAYBACK LEVEL ADJUSTMENTS

- 1) Set Tape Speed Selector to 7-1/2 ips.
- 2) Set Monitor Switch to TAPE position.
- 3) Playback a 250 Hz recorded test tape at 7-1/2 ips.
- 4) Adjust Playback Amp. P.C. Board semi-fixed resistors VR1 50 k $\Omega$  (left ch.), and VR1b 50 k $\Omega$  (right ch.) shown in Fig. 19 to obtain a high sensitivity V.T.V.M. indication of 4 dB (1.228V) line output level on both channels.
- 5) When making the left channel line output level adjustment, press playback head slightly downward with one finger and regulate to 4 dB.

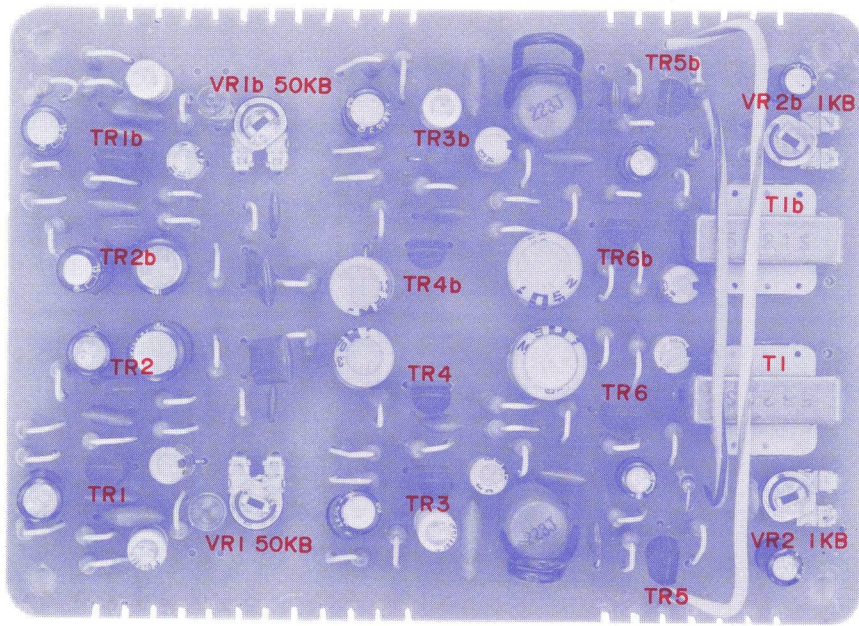

Fig. 22 PLAYBACK AMP. P.C. BOARD ND-5037

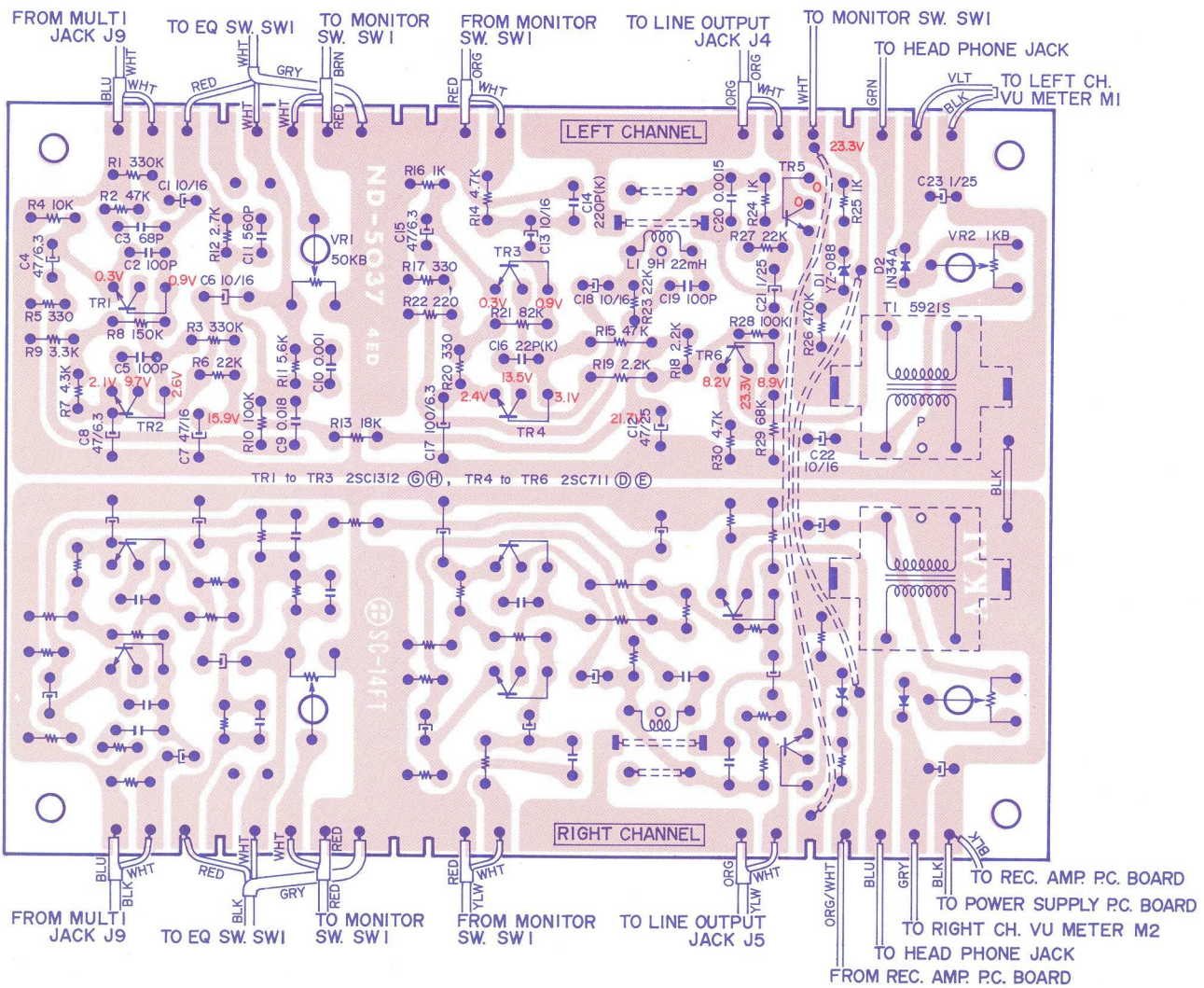

Fig. 23 PLAYBACK AMP. P.C. BOARD ND-5037 (Reverse Side)

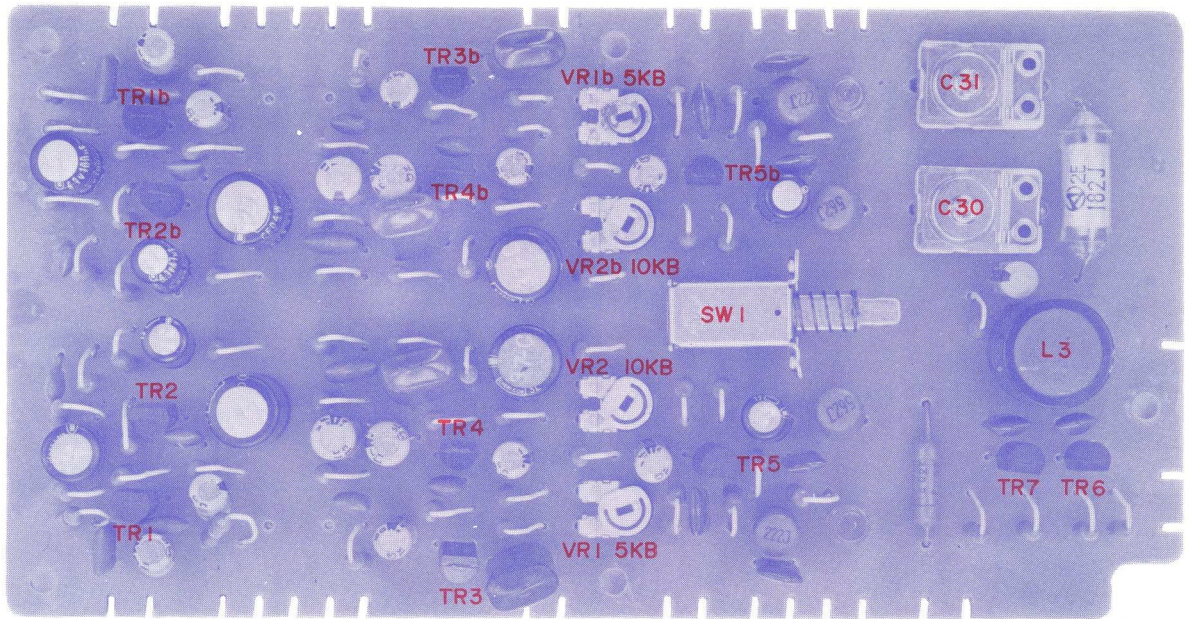

Fig. 24 RECORDING AMP. P.C. BOARD MU-5016

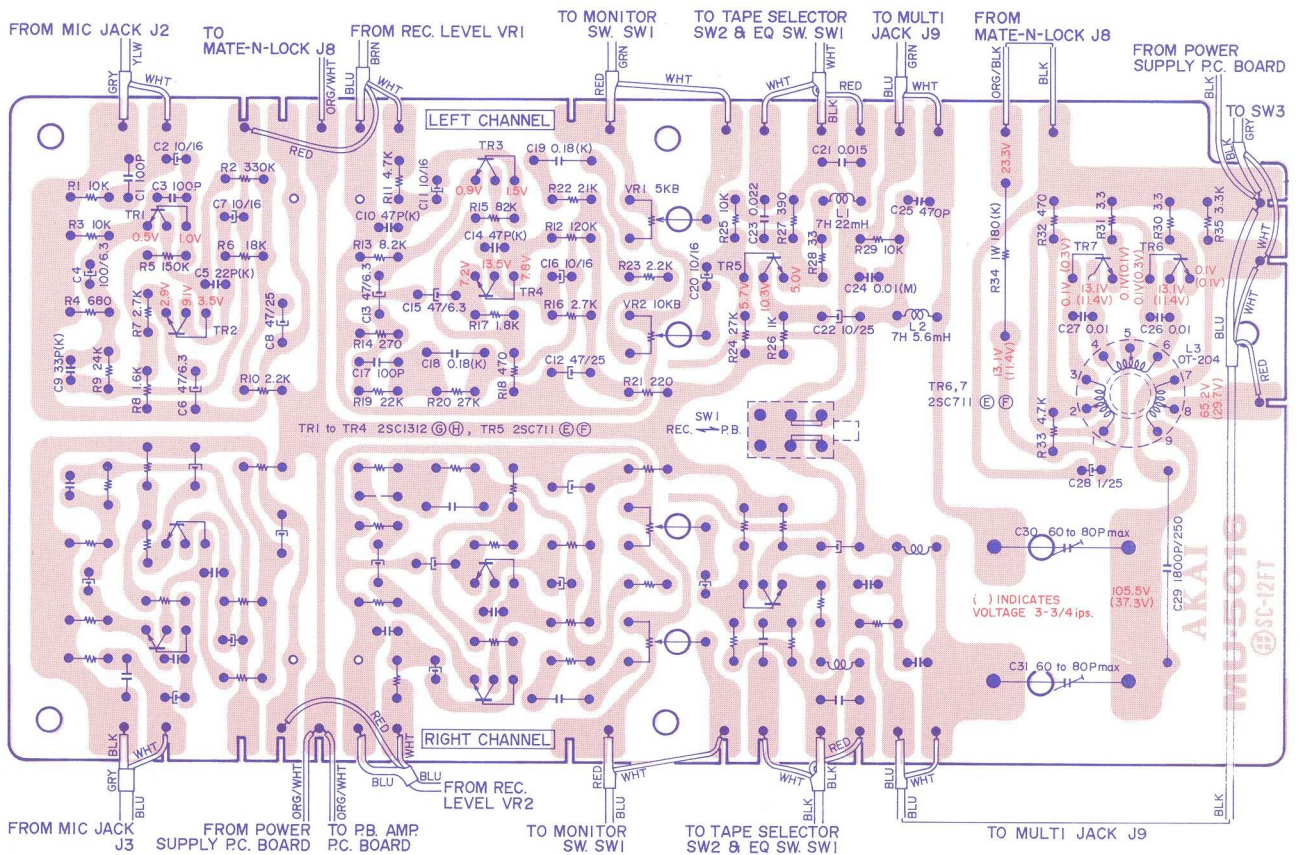

Fig. 25 RECORDING AMP. P.C. BOARD MU-5016 (Reverse Side)

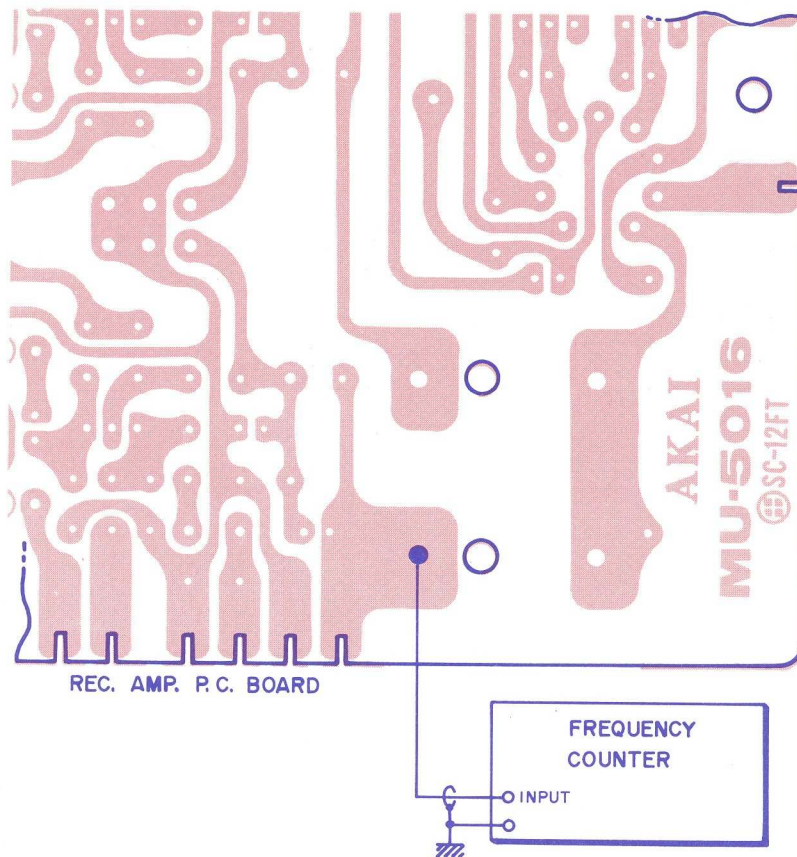

Fig. 26

## 2. VU METER SENSITIVITY ADJUSTMENT

After playback level adjustments has been completed, with the playback level of both channels at 4 dB, adjust P.B. Amp. P.C. Board semi-fixed resistors VR2 1 k $\Omega$  (left ch.) and VR2b 1 k $\Omega$  (right ch.) shown in Fig. 19 to obtain a left/right VU meter indication of 0 VU.

## 3. HIGH RANGE FREQUENCY DEVIATION CHECK

### 1) Between Channels

When an 8,000 Hz 3-3/4 ips. Ampex Alignment Test Tape is played back at 7-1/2 ips, check to confirm that the difference in high range output between left and right channel is within 3 dB at FWD mode and within 4 dB at REV mode.

### 2) Between FWD and REV Playback

When an 8,000 Hz 3-3/4 ips. Ampex Alignment Test Tape is played back at 7-1/2 ips, check to confirm that the difference in high range output between FWD and REV playback is within 3.5 dB.

3) If in Items 3-1) and 3-2) above, the difference is not within specifications, repeat Head Azimuth Alignment adjustment.

## 4. RECORDING LEVEL ADJUSTMENT

- 1) Set Tape Speed Selector to 7-1/2 ips.
- 2) Set Monitor Switch to TAPE position.
- 3) Set Left and Right ch. recording level to maximum (turn fully clockwise) and load a blank tape.
- 4) Set tape deck to recording mode and supply a 1,000 Hz, -70 dB (0.25 mV) sine wave signal to the Mic Inputs from the audio frequency oscillator.
- 5) Adjust Recording Amp. P.C. Board semi-fixed resistors VR2 10 k $\Omega$  (left ch.) and VR2b 10 k $\Omega$  (right ch.) shown in Fig. 19 to obtain a high sensitivity V.T.V.M. indication of 4 dB (1.228V) line output level on both channels.
- 6) Set Monitor Switch to SOURCE position.
- 7) Adjust Recording Amp. P.C. Board semi-fixed resistors VR1 5 k $\Omega$  (left ch.) and VR1b 5 k $\Omega$  (right ch.) shown in Fig. 19 to obtain a high sensitivity V.T.V.M. indication of 4 dB (1.228V) line output level on both channels.

NOTE: In Item 4) above if sine wave is supplied to Line Input, set audio frequency oscillator output to -24.5 dB (46 mV).



---

## 5. FREQUENCY RESPONSE ADJUSTMENT

- 1) Set Tape Speed Selector to 7-1/2 ips.
- 2) Set Monitor Switch to TAPE position.
- 3) Set Left and Right ch. recording level to maximum (turn fully clockwise) and load a blank tape.
- 4) Set tape deck to recording mode and supply a 2,000 Hz sine wave signal to the Mic or Line Inputs. Adjust attenuator to obtain a high sensitivity V.T.V.M. indication of -16 dB (120 mV) line output level.
- 5) Switch the oscillation frequency of the audio frequency oscillator from the condition described in Item 5-4) above to 20,000 Hz.
- 6) Adjust Recording Amp. P.C. Board Trimmer Condenser C30 80p max (left ch.) and C31 80p max (right ch.) shown in Fig. 19 until the same high sensitivity V.T.V.M. indication level is obtained on both the left and right channel at the two frequencies described in Items 5-4) and 5-5) above.

## 6. RECORDING BIAS FREQUENCY MEASURING METHOD

As shown in Fig. 26, connect a Frequency Counter to the output side of the trimmer condenser. Set tape deck to recording mode, and take a frequency counter reading. Specifications are 102 kHz $\pm$ 5%.

## VIII. D.C. RESISTANCE OF VARIOUS COIL

D.C. Resistance shown in chart are average values.

Parts	Designation	D.C. Resistance
CAPSTAN MOTOR	HM-12-16MC	Between PNK-RED 130Ω Between PNK-BRN 180Ω Between GRN-GRY 360Ω Between GRN-YLW 370Ω
REEL MOTOR	24XO-MR	Between RED-BLU 74Ω Between GRN-YLW 166Ω
HEAD REVERSE SOLENOID	RGA-10143	630Ω
REVERSE RELAY	MY4-0-US-AD4 DC24V	650Ω
HEADPHONE OUTPUT TRANSFORMER	5921S	Primary 230Ω Secondary 0.9Ω
OSCILLATOR COIL	OT-204	Between 1-3 0.3Ω Between 4-6 0.7Ω Between 7-9 8.2Ω
COMBO HEAD	RE4-6	5.5Ω (REC) 2.3Ω (ERASE)
PLAYBACK HEAD	P4-202	268Ω

Chart 2



2. EQ. P.C. BOARD MU-5018

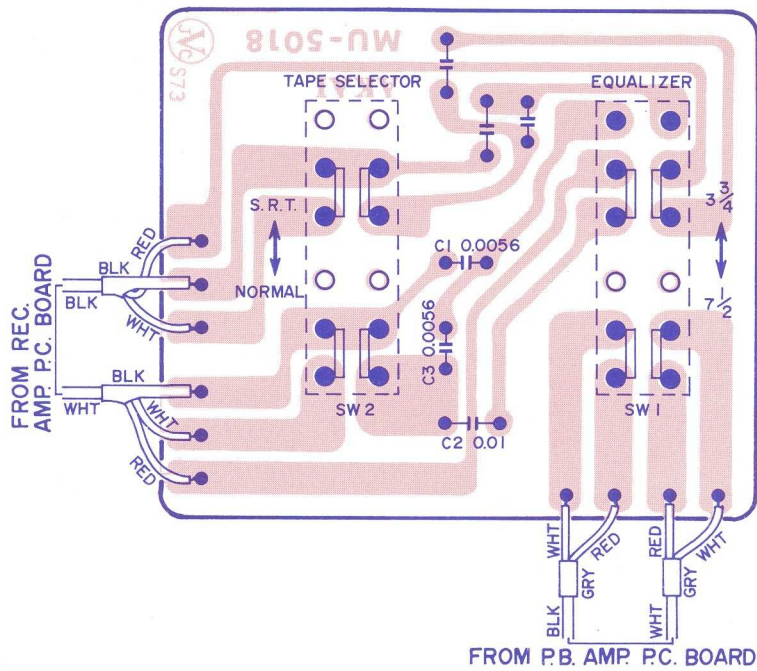

3. CR. P.C. BOARD MU-1007

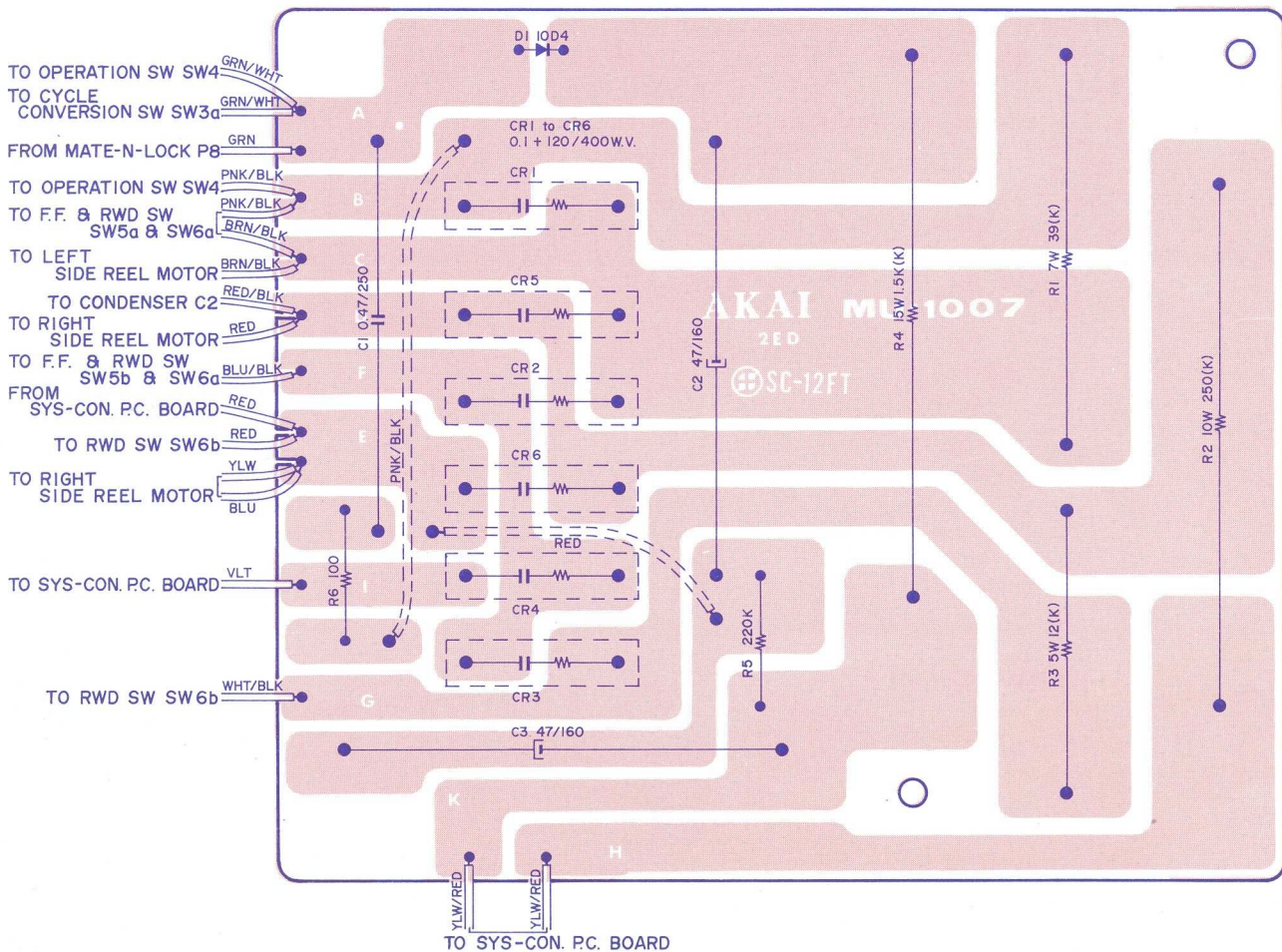

#### 4. POWER SUPPLY P.C. BOARD MU-5017

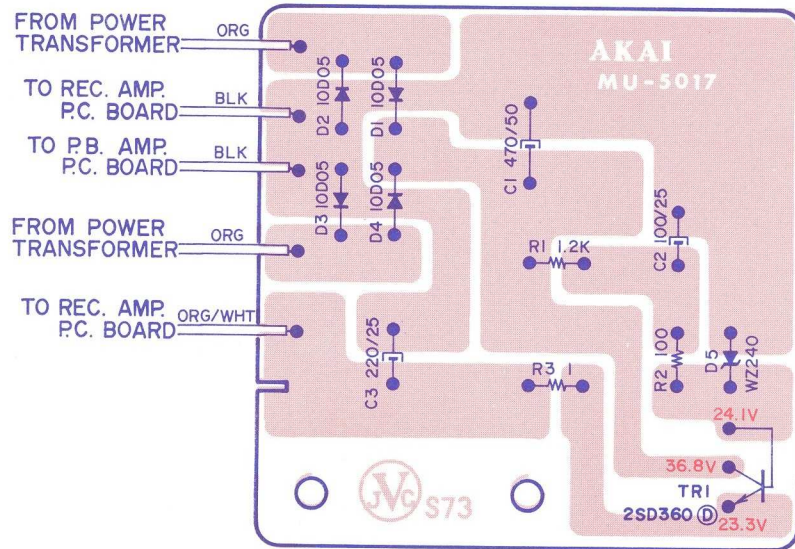



---

SECTION 2

**PARTS LIST**

TABLE OF CONTENTS

FIG. 1	MU GX HEAD BLOCK .....	34
FIG. 2	REEL MOTOR & REEL TABLE BLOCK .....	36
FIG. 3	MAIN MOTOR BLOCK .....	38
FIG. 4	FLYWHEEL BLOCK .....	39
FIG. 5	SWITCH BLOCK .....	40
FIG. 6	MECHANISM ASSEMBLY BLOCK .....	41
FIG. 7	SYS. CON. P.C. BOARD (MU-1006) BLOCK .....	44
FIG. 8	CR P.C. BOARD (MU-1007) BLOCK .....	45
FIG. 9	REC. AMP. P.C. BOARD (MU-5016) BLOCK .....	46
FIG. 10	P.B. AMP. P.C. BOARD (ND-5037) BLOCK .....	47
FIG. 11	EQ. P.C. BOARD (MU-5018) BLOCK .....	48
FIG. 12	POWER SUPPLY P.C. BOARD (MU-5017) BLOCK .....	49
FIG. 13	AMPLIFIER ASSEMBLY BLOCK .....	50
FIG. 14	FINAL ASSEMBLY BLOCK .....	52
INDEX	.....	54

## HOW TO USE THIS PARTS LIST

1. This parts list is compiled by various individual blocks based on assembly process.
2. When ordering parts, please describe parts number, serial number, and model number in detail.
3. How to read List

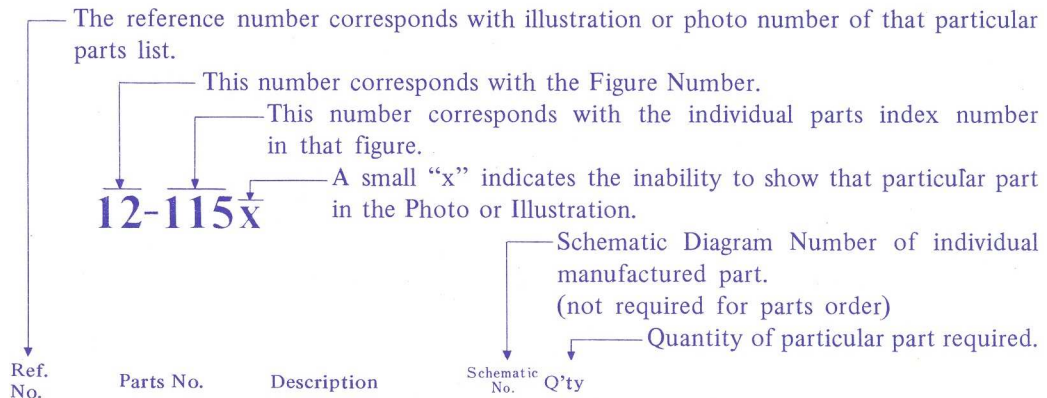

### FLYWHEEL BLOCK #13

Ref. No.	Parts No.	Description	Schematic No.	Q'ty
12-115x	800425	Flywheel Block Assy. Comp.	RDG #13	1
12-116	244506	Flywheel Only	RD-233	1
12-117x	244754	Felt, Flywheel	RD-275	1
12-118	251324	Main Metal Case	RD-236	1
12-119	253080	Main Metal	RD-237	1

4. The symbol numbers shown on the P.C. Board list can be matched with the Composite Views of Components of the Schematic Diagram or Service Manual.
5. The indications of Resistors and Capacitors in the photos of P.C. Board are being eliminated.
6. The shape of the parts and parts name, etc. can be confirmed by comparing them with the parts shown on the Electrical Parts Table of P.C. Board.
7. Both the kind of part and installation position can be determined by the Parts Number. To determine where a parts number is listed, utilize Parts Index at end of Parts List.  
It is necessary first of all to find the Parts Number. This can be accomplished by using the Reference Number listed at right of parts number in the Parts Index. (meaning of ref. no. outlined in Item 3 above).
8. Utilize separate "Price List for Parts" to determine unit price. The most simple method of finding parts Price is to utilize the reference number.



## ELECTRICAL PARTS TABLE

<p>Because the indication of resistors and capacitors in the P.C. Board photos are being eliminated, please confirm parts name and shape by comparing them with the parts shown in this table.</p>	<p style="text-align: center;">1</p>  <p style="text-align: center;">Solid Resistor</p>	<p style="text-align: center;">2</p>  <p style="text-align: center;">Carbon Resistor</p> <p style="text-align: right;">Stopper Type Insulator Type</p>	<p style="text-align: center;">3</p>  <p style="text-align: center;">Metal Oxide Film Resistor</p>
<p style="text-align: center;">4</p>  <p style="text-align: center;">Cement Resistor</p>	<p style="text-align: center;">5</p>  <p style="text-align: center;">Wire-Wound Resistor</p>	<p style="text-align: center;">6</p>  <p style="text-align: center;">Thermister</p>	<p style="text-align: center;">7</p>  <p style="text-align: center;">Enamel Resistor</p>
<p style="text-align: center;">1</p>  <p style="text-align: center;">MP Capacitor (Tubular Type)</p>	<p style="text-align: center;">2</p>  <p style="text-align: center;">Plastic Capacitor</p>	<p style="text-align: center;">3</p>  <p style="text-align: center;">Mylar Capacitor</p>	<p style="text-align: center;">4</p>  <p style="text-align: center;">VFM (Hi-Q) Capacitor</p>
<p style="text-align: center;">5</p>  <p style="text-align: center;">Mylar Capacitor</p>	<p style="text-align: center;">6</p>  <p style="text-align: center;">Tantalum Capacitor</p>	<p style="text-align: center;">7</p>  <p style="text-align: center;">Oil Capacitor (Tubular Type)</p>	<p style="text-align: center;">8</p>  <p style="text-align: center;">Styrol Capacitor</p> <p style="text-align: right;">Vertical Type Tubular Type</p>
<p style="text-align: center;">9</p>  <p style="text-align: center;">Electrolytic Capacitor (Tubular Type)</p>	<p style="text-align: center;">10</p>  <p style="text-align: center;">Electrolytic Capacitor</p> <p style="text-align: right;">Vertical Type Tubular Type</p>	<p style="text-align: center;">11</p>  <p style="text-align: center;">Ceramic Capacitor</p>	<p style="text-align: center;">12</p>  <p style="text-align: center;">Metalized Mylar (Paper) Capacitor</p>
<p style="text-align: center;">13</p>  <p style="text-align: center;">Trimmer Condenser</p>		<p style="text-align: center;">VR</p>  <p style="text-align: center;">Semi-Fixed Volume</p>	
<p style="text-align: center;">L</p>  <p style="text-align: center;">Ferri Inductor</p>	<p style="text-align: center;">TR</p>  <p style="text-align: center;">Transistor</p>		
<p style="text-align: center;">CR</p>  <p style="text-align: center;">Spark Quencher</p>	<p style="text-align: center;">D</p>  <p style="text-align: center;">Diode (Silicon, Zener, Germanium)</p>		

FIG. 1 ILLUSTRATION OF MU GX HEAD BLOCK

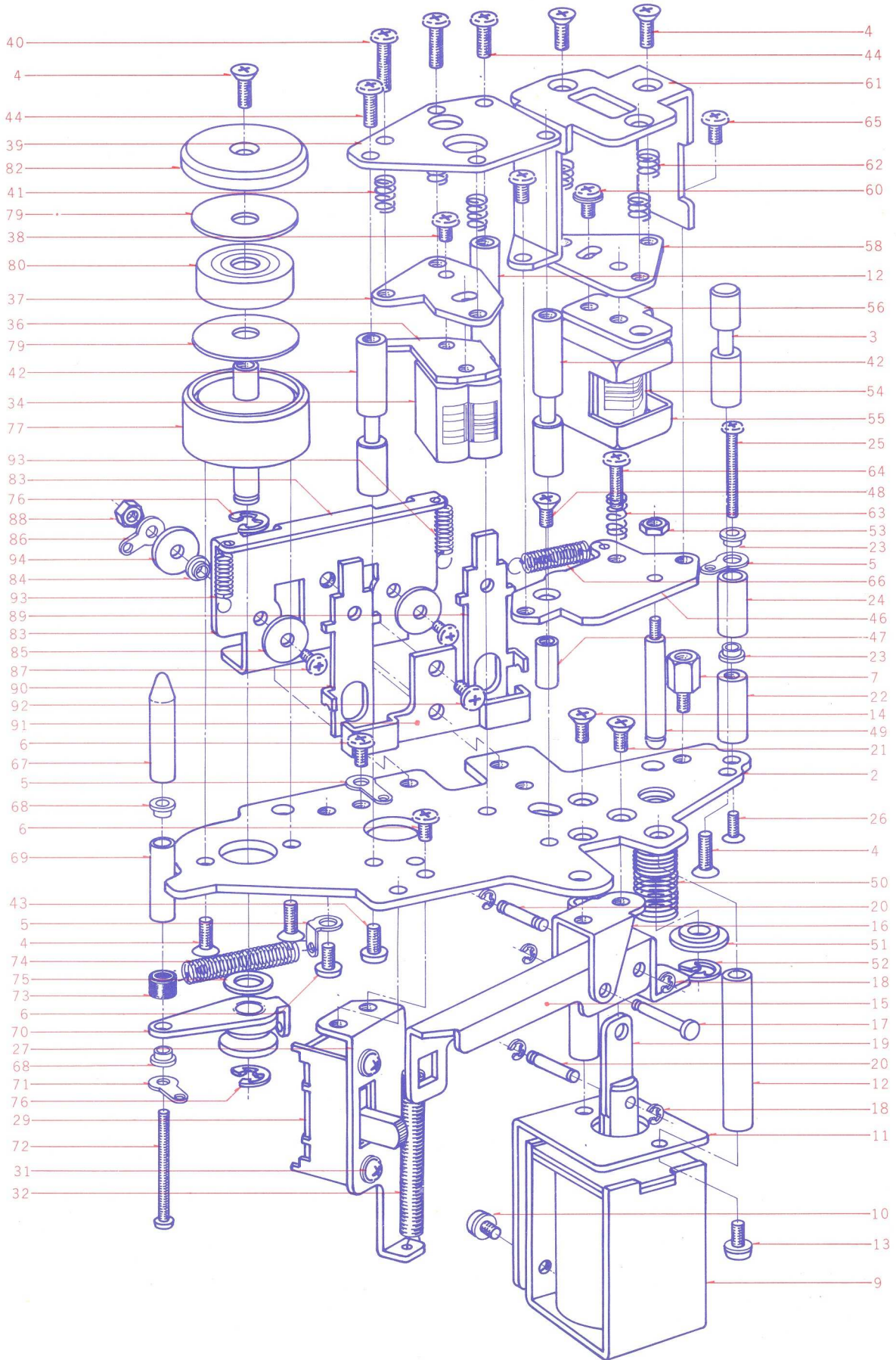

## MU GX HEAD BLOCK

Ref. No.	Parts No.	Description	Schematic No.	Q'ty	Ref. No.	Parts No.	Description	Schematic No.	Q'ty
1-1x	BH558358	MU GX Head Block Comp.	MU	1	1-72	ZS554962	Screw, pan head 2.3x25		1
1-2	HZ544498	Head Base, w/metal	MU-0001	1	1-73	HZ467010	Cushion Rubber, MC	MC-0004	1
1-3	HZ317597	Tape Guide A, MR	MR-4	1	1-74	ZG317114	Tension Lever Spring	MR-39	1
1-4	ZS414033	Screw, countersunk head 3x8		7	1-75	ZW259885	Washer (PBP)D5.1x10.3x0.1t		1
1-5	ZW273778	Earth Lug M3		4	1-76	ZW270123	'E' Ring 4M	6-1-9	2
1-6	ZS323728	Screw, binding head 3x5		5	1-77	HZ547751	Tape Guide A, w/shaft	MU-0015	1
1-7	HZ541170	Panel Support	MC-0209	1	1-78x	MS318093	Guide Roller Shaft	MR-30	1
1-8x	ED224548	Silicon Diode 10D2	45-2-14	1	1-79	ZW231805	Tape Guide Washer (large)	3A-356	2
1-9	EP558123	Plunger Solenoid			1-80	MV248117	Bearing 635AHZZMC1ERB32		1
		SDC-840FHT1	44-1-59	1	1-81x	ZW326463	Washer (PBP)D5.1x10.3x0.2t		1
1-10	ZS555737	ISO Screw, binding head 3x6, w/washer		2	1-82	HZ317092	Tape Guide Table B	MR-32	1
1-11	HZ544252	Solenoid Mt. Plate	MU-0008	1	<b>MECH. ASSEMBLY BLOCK</b>				
1-12	MH544195	Head Base Prop	MU-0002	3	1-83	ML544285	D.S Table	MU-0011	1
1-13	ZS413728	Screw, binding head 3x6, w/washer		2	1-84	MZ316822	Insulator Collar B	MR-225	2
1-14	ZS200384	Screw, countersunk head 3x6		2	1-85	HZ542092	Insulator Washer	MC-0213	2
1-15	HL544241	Solenoid Lever	MU-0007	1	1-86	ZW316800	Earth Lug M2.6		2
1-16	HZ317687	Lever Support	MR-15	1	1-87	ZS464692	Screw, binding head 2.3x6		2
1-17	MH257477	Connecting Pin	RD-211	1	1-88	ZW273688	Nut M2.3		2
1-18	ZW270088	'E' Ring 1.9M	6-1-9	5	1-89	HL541168	D.S Lever A	MC-0208	1
1-19	HZ544263	Pull Plate	MU-0009	1	1-90	HL542687	D.S Lever B	MC-0208	1
1-20	HZ544274	Solenoid Pin	MU-0010	2	1-91	HL541157	D.S Lever Support	MC-0207	1
1-21	ZS559056	Screw, countersunk head 3x6		2	1-92	ZS417137	Screw, binding head 3x4		2
1-22	HZ455962	Sensing Collar B	MC-1019	1	1-93	ZG317777	Pull Spring	MR-47	2
1-23	HZ317632	Insulator Collar A	MR-36	2	1-94	ZW563218	Washer (Bake)D3.2x10x1t		2
1-24	HZ455973	Sensing Collar A	MC-1018	1	1-95x	ZS558101	Screw, pan head 3x6, w/washer		2
1-25	ZS554916	Screw, binding head 2.3x20		1					
1-26	ZS558134	Screw, countersunk head 2.3x5		1					
1-27	HZ317733	Slide SW. Base	MR-18	1					
1-28x	EA382713	Head Connector P.C. Board	RD-A8	1					
1-29	ES317744	Slide SW. SL-242B4V	25-3-28	1					
1-30x	ZW317801	Toothed Lock Washer M2.6		2					
1-31	ZS372183	Screw, round head 2.6x5		2					
1-32	ZG317766	Plunger Lever Spring	MR-19	1					
1-33x	HZ583176	RE4-6 Terminal Plate	TW-0035	1					
1-34	HR556582	REC./ERASE HEAD RE4-6		1					
1-35x	ZS461395	Screw, round head 2x3		2					
1-36	HZ544230	Head Mt. Angle	MU-0006	1					
1-37	HZ544228	Head Angle Base	MU-0005	1					
1-38	ZS417137	Screw, binding head 3x4		2					
1-39	HZ544217	Head Mt. Plate	MU-0004	1					
1-40	ZS413785	Screw, binding head 3x12		3					
1-41	ZG540584	Angle Adjust Spring G	TW-0025	3					
1-42	HZ544206	Tape Guide	MU-0003	2					
1-43	ZS413741	Screw, binding head 3x8		3					
1-44	ZS396044	Screw, binding head 3x8		3					
1-45x	ZW430863	Washer (SPC)D3.3x6x0.5t		2					
1-46	HZ531551	Base Plate B	MR-10	1					
1-47	HZ298012	4-TR Hold-down Base Guide	3A-69	1					
1-48	ZS554938	Screw, countersunk head 2.3x6		1					
1-49	HZ541135	PH Shaft	MC-0205	1					
1-50	ZG317902	PH Spring	MR-13	1					
1-51	ZW317913	Spring Holder	MR-12	1					
1-52	ZW290283	'U' Ring 2.85M	6-1-1	1					
1-53	ZW554940	Nut M3		1					
1-54	HP536501	P.B. HEAD P4-202		1					
1-55	HZ411017	Head Shield Case	LF-0005	1					
1-56	HZ541124	Head Mt. Angle	MC-0204	1					
1-57x	ZS460440	Screw, pan head 2x4		2					
1-58	HZ541113	Angle Base	MC-0203	1					
1-59x	EA463206	Terminal P.C. Board A	RD-A36	2					
1-60	ZS558257	Screw, binding head 3x5, w/washer		2					
1-61	HZ541102	Base Angle	MC-0203	1					
1-62	ZG317968	Angle Spring	MR-14	3					
1-63	ZG466312	Angle Adjust Spring E	BS-0018	1					
1-64	ZS425114	Screw, round head 3x10		1					
1-65	ZS384131	Screw, round head 3x5		2					
1-66	ZG317777	Pull Spring	MR-47	1					
1-67	HZ541181	Sensing Post B	MC-0210	1					
1-68	HZ317632	Insulator Collar A	MR-36	2					
1-69	HZ318047	Sensing Collar A	MR-35	1					
1-70	HZ318036	Tension Arm, w/pulley	MR-37	1					
1-71	ZW316800	Earth Lug M2.6		1					

When ordering parts, please describe Parts Number, Serial Number, and Model Number in detail.

FIG. 2 ILLUSTRATION OF REEL MOTOR & REEL TABLE BLOCK

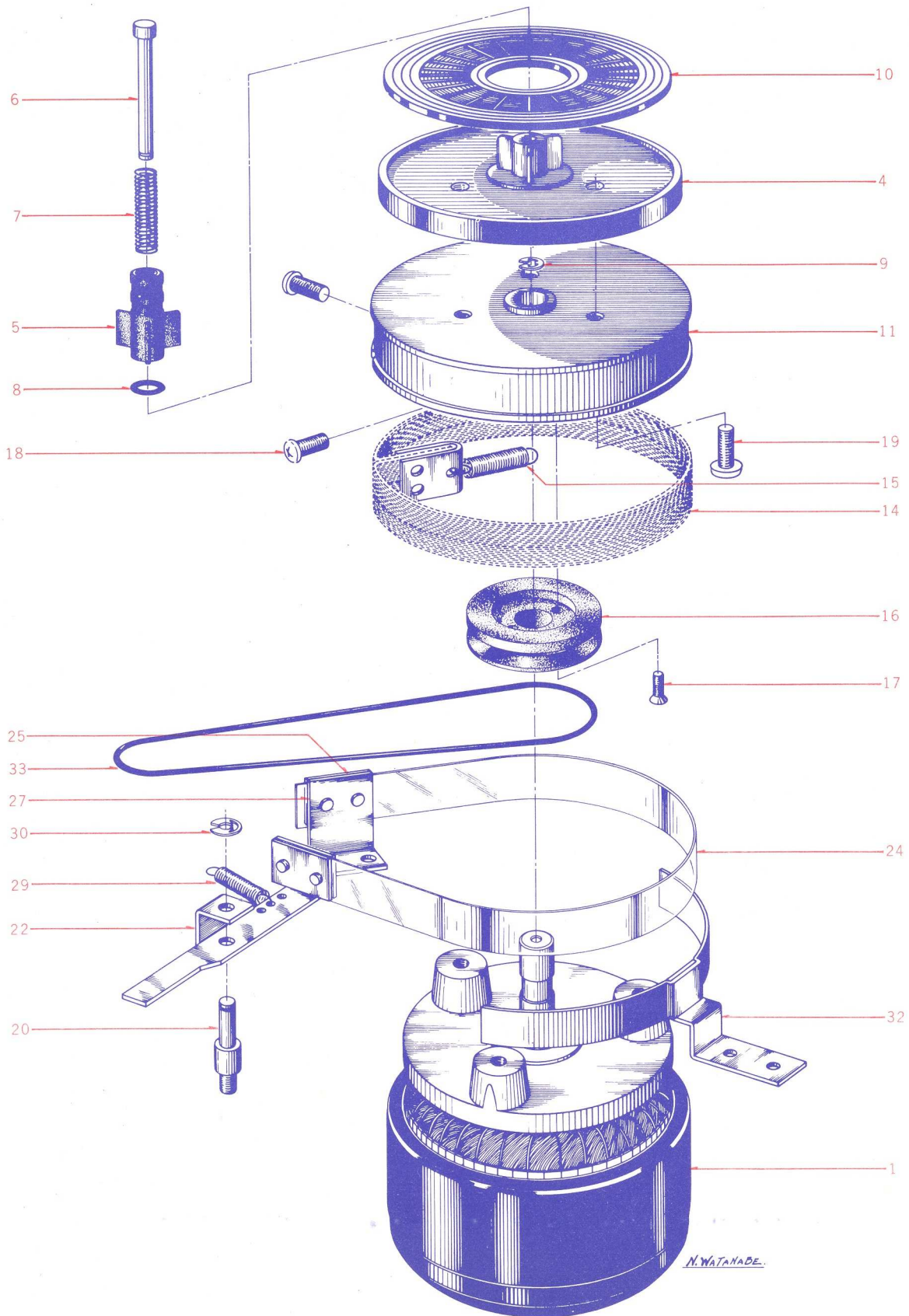

## REEL MOTOR & REEL TABLE BLOCK

Ref. No.	Parts No.	Description	Schematic No.	Q'ty
2-1	BM314741	Reel Motor Block (24XO-2)		
		Comp. MR, KD, MS, MC		1
2-2x	BR317395	Supply Reel Table Block		
		Comp. MU, MC, MR		1
2-3x	BR317384	Take-up Reel Table Block		
		Comp. MU, MR		1
2-4	MT317441	Reel Table, MR	MR-215	2
2-5	MT255420	Reel Retainer	3R-102	2
2-6	MS342000	Reel Shaft	3R-108	2
2-7	ZG255633	Reel Spring	3R-109	2
2-8	MT297663	3R 'O' Ring 2.9x1.65M	3R-139	2
2-9	ZW270088	'E' Ring 1.9M	6-1-9	2
2-10	MT317463	Reel Table Rubber, MR	MR-250	1
2-11	MT317452	Brake Drum (R) (Take-up)	MR-216	1
2-12x	MT325473	Brake Drum (L) (Supply)	MR-216	1
2-13x	ZW273778	Earth Lug M3		2
2-14	MT436860	Brake Cloth Comp.	MR-269	2
2-15	ZG317496	Felt Tension Spring	MR-260	2
2-16	MR317507	Counter Pulley (Take-up)	MR-217	1
2-17	ZS365973	Screw, countersunk head		
		2.3x12		2
2-18	ZS424056	Screw, pan head 4x10		4
2-19	ZS413785	Screw, binding head 3x12		6

### MECH. ASSEMBLY BLOCK

2-20	MH317373	Brake Lever Prop	MR-102	2
2-21x	ZW416698	Nut M4		2
2-22	ML314976	Brake Lever A (Take-up)	MR-210	1
2-23x	ML396810	Brake Lever B (Supply)	KD-1038	1
2-24	MT314987	Brake Band	MR-213	2
2-25	MZ314998	Brake Band Retaining Plate	MR-212	4
2-26x	ZS417137	Screw, binding head 3x4		6
2-27	MZ315000	Brake Band Support	MR-214	2
2-28x	ZS425981	Screw, binding head 3x3		2
2-29	ZG315011	Brake Lever Spring	MR-116	2
2-30	ZW290283	'U' Ring 2.85M	6-1-1	2
2-31x	ZS323728	Screw, binding head 3x5		8
2-32	MZ317406	Brake Band Guide, w/base	MR-120	2
2-33	MB230286	Timer Belt D74x1.4 (Counter)	3A-120	1

FIG. 3 ILLUSTRATION OF MAIN MOTOR BLOCK

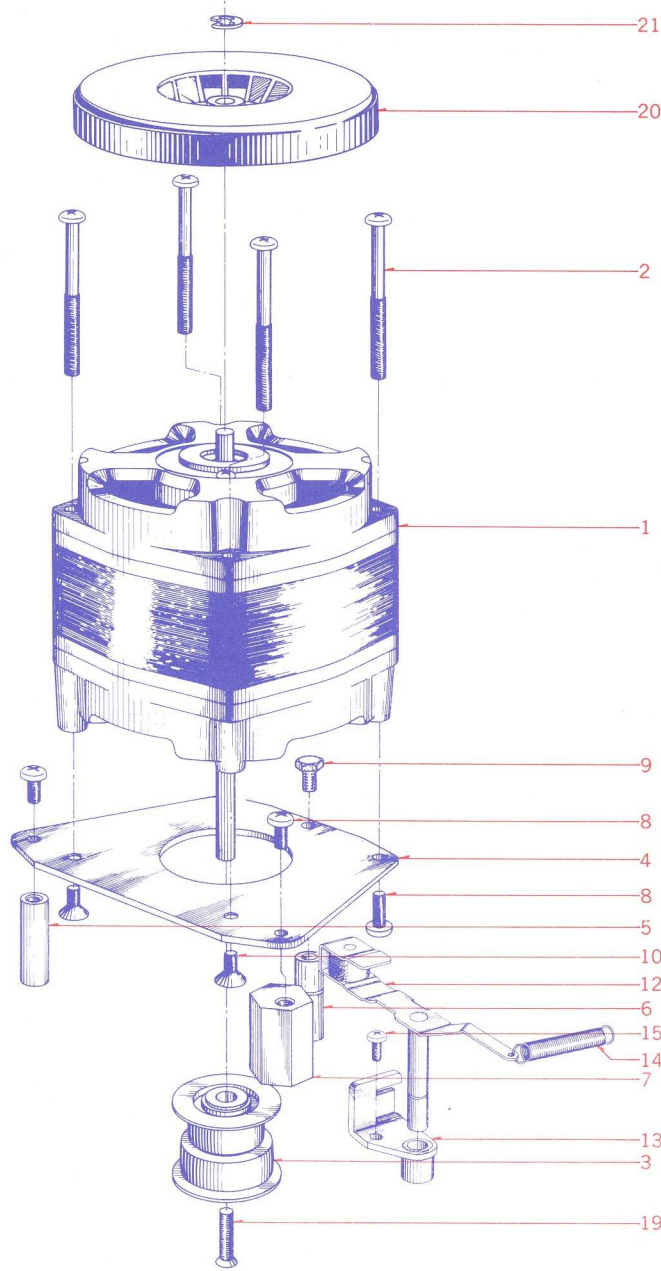

**MAIN MOTOR BLOCK**

Ref. No.	Parts No.	Description	Schematic No.	Q'ty
<b>MAIN MOTOR BLOCK</b>				
3-1	BM563196	Main Motor Block (HM2-16MU) Comp.	MU	1
3-2	ZS427037	Screw, pan head 4x50, w/washer		4
3-3	MR540876	Motor Pulley Comp.	MC-7201	1
3-4	MZ316293	Motor Mt. Plate, MR	MR-717	1
3-5	MH254160	Motor Prop A	24X-730	1
3-6	MZ254182	Motor Prop B	24X-731	1
3-7	MH316304	Motor Prop, MR	MR-706	1
3-8	ZS424056	Screw, pan head 4x10		4
3-9	ZS272395	Motor Prop Retaining Screw, M-7	24X-732	1
3-10	ZS427026	Screw, countersunk head 4x10		2

Ref. No.	Parts No.	Description	Schematic No.	Q'ty
<b>BELT CHANGE LEVER BLOCK</b>				
3-11x	BL555344	Belt Change Lever Block Comp.	MU,MC-2	1
3-12	ML540990	Belt Change Lever, w/roller	MC-1207	1
3-13	ML541001	Belt Change Lever Stopper, w/metal	MC-1208	1
3-14	ZG217337	Belt Return Spring	4TR-224	1
3-15	ZS417150	Screw, pan head 4x6		1
3-16x	ZG217394	Belt Change Spring B	MH-125	1
3-17x	ZW260054	Washer (SUP)D6.1x10x0.25t		1
3-18x	ZW290283	'U' Ring 2.85M	6-1-1	1
3-19	ZS203016	Screw, oval countersunk head 3x15		1
3-20	SZ529108	Main Motor Fan	ND-7010	1
3-21	ZW270134	'E' Ring 5M	6-1-9	1

When ordering parts, please describe Parts Number, Serial Number, and Model Number in detail.

FIG. 4 ILLUSTRATION OF FLYWHEEL BLOCK

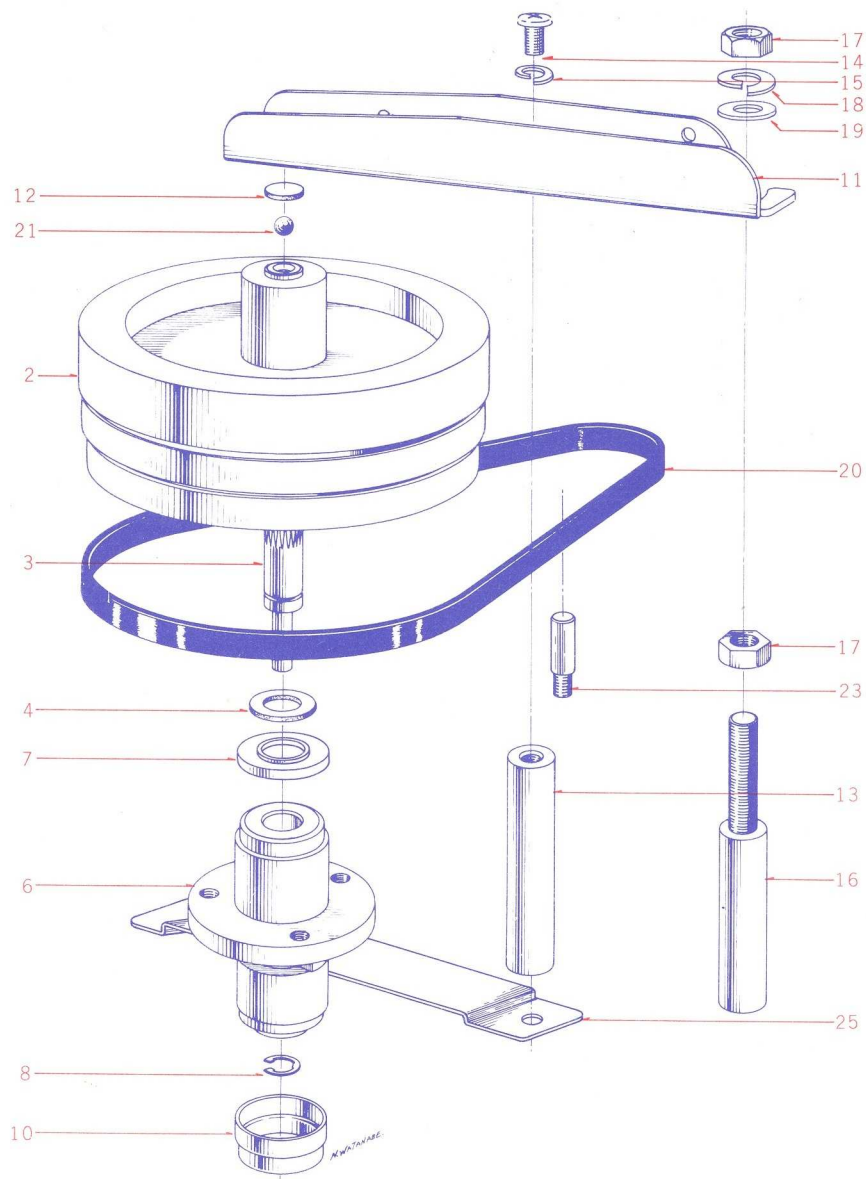

**FLYWHEEL BLOCK**

Ref. No.	Parts No.	Description	Schematic No.	Q'ty	Ref. No.	Parts No.	Description	Schematic No.	Q'ty
4-1x	BF476550	Flywheel Block Comp.	MR-2,MS-2.3	1	4-13	MH273036	Flywheel Prop A, M-9	M9-310	1
4-2	MI296245	Flywheel 24	MH-202	1	4-14	ZS413201	Screw, pan head 4x8		1
4-3	MS476572	Main Shaft, D6	MR-2005	1	4-15	ZW273914	Spring Washer M4		3
4-4	ZW447208	Flywheel Thrust B			4-16	MH273047	Flywheel Prop B, M-9	M9-311	1
		D7.9x13x0.5t	101025	1	4-17	ZW413280	Inch Nut 1/4" mountain 20		2
4-5x	ZS373577	Set Screw, hexagon socket			4-18	ZW393232	Spring Washer 1/4"		1
		5x6(flat)		2	4-19	ZW413998	Washer (SUP)D6.8x12.7x1t		1
4-6	MZ296256	Main Case A 24, w/metal	MH-206	1	4-20	MB541012	Drive Belt (Flat)D116.9x1.6x7	MC-1209	1
4-7	MZ446635	Thrust Cap, Main Metal B2	LF-2006	1	4-21	MV269965	Steel Ball D4		1
4-8	MH244710	Flywheel Fixing Pin	900-250	1	4-22x	ZS424056	Screw, pan head 4x10		2
4-9x	MZ244113	Felt D12.5x16x2t		1	4-23	MH248343	Belt Guide Pin	4TR-109	1
4-10	MZ253113	Main Metal Cap B	MH-208	1	4-24x	ZW416698	Nut M4		1
					4-25	MZ439525	Flywheel Belt Holding Plate B	MS-1014	1
					4-26x	ZS439514	Screw, binding head 3x18		1
					4-27x	ZW273756	Nut M3		1
<b>MECH. ASSEMBLY BLOCK</b>									
4-11	MZ314897	Flywheel Support Plate, MR	MR-121	1					
4-12	ZW392681	Washer (Nylon)D8x1t (without hole)		1					

When ordering parts, please describe Parts Number, Serial Number, and Model Number in detail.

FIG. 5 ILLUSTRATION OF SWITCH BLOCK

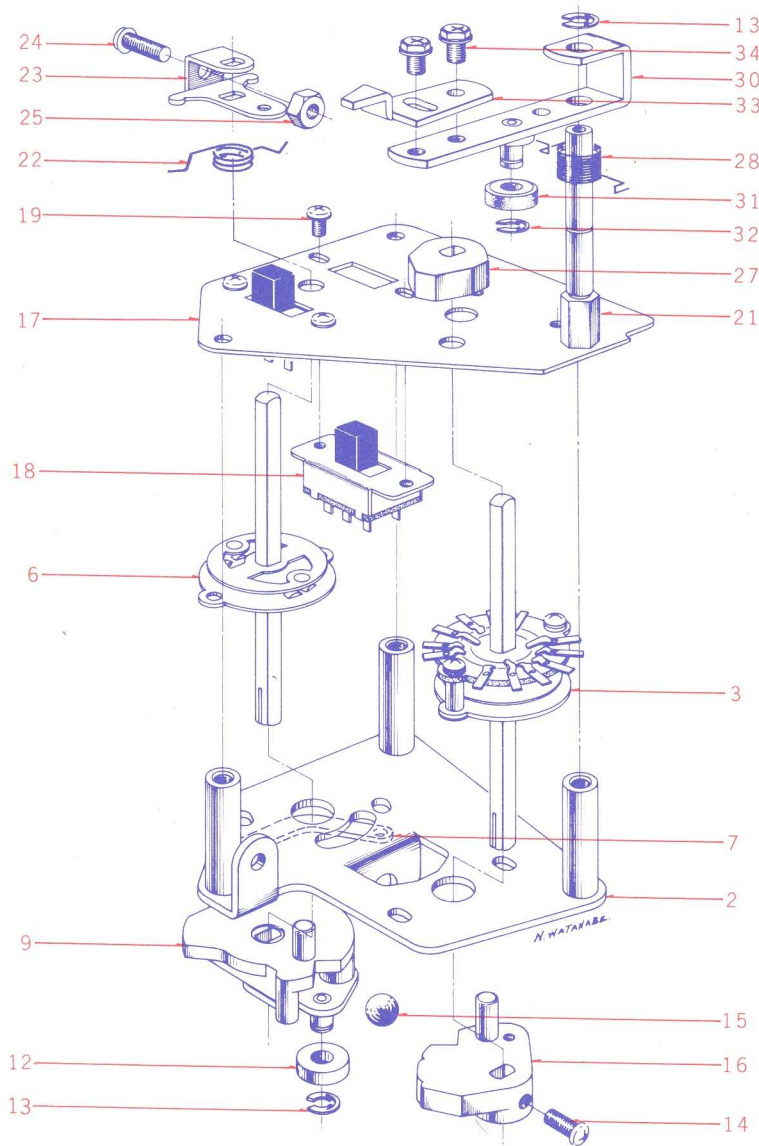

**SWITCH BLOCK**

Ref. No.	Parts No.	Description	Schematic No.	Q'ty	Ref. No.	Parts No.	Description	Schematic No.	Q'ty
<b>SWITCH BLOCK</b>					<b>SWITCH LEVER BLOCK</b>				
5-1x	BS558336	Switch Block Comp.	MU	1	5-20x	ZS559045	Screw, binding head 4x8, w/washer		2
5-2	HZ402390	SW. Table A-2, MR (w/prop)	MR-201	1	5-21	MH317046	REC. Lever Prop	MR-206	1
5-3	ES316923	Play Shaft (Y type) Y-133	25-8-6	1	5-22	ZG225516	SW. Spring	MR-255	1
5-4x	ZW273802	Toothed Lock Washer M3		2	5-23	MZ317024	SW. Cam	MR-204	1
5-5x	ZW273756	Nut M3		2	5-24	ZS424056	Screw, pan head 4x10		1
5-6	ES316934	Rewind Shaft (Y type)	25-8-5	1	5-25	ZW416698	Nut M4		1
5-7	MZ316945	Nut Plate	MR-245	1	5-26x	ZS323728	Screw, binding head 3x5		3
5-8x	ZS413728	Screw, binding head 3x6, w/washer		2	5-27	MZ317068	Amp. SW. Cam B	MR-243	1
5-9	MZ316956	Cam A-3, w/plate	MR-242	1	5-28	ZG227564	Spring H	900-120	1
5-10x	ZW259942	Washer (Fiber)D5.1x10.3x0.5t		1					
5-11x	ZW376402	Washer (Fiber)D5.1x10.3x1t		2					
5-12	MR269730	Cam Roller D12	900-213	1	5-29x	BL204480	Switch Lever Block Comp.	MR	1
5-13	ZW290283	'U' Ring 2.85M	6-1-1	2	5-30	ML226080	SW. Lever A, w/shaft B	900-255	1
5-14	ZS413201	Screw, pan head 4x8		3	5-31	MR217203	Cam Roller A (Nylon)D12	900-153	1
5-15	MV270066	Steel Ball D8		1	5-32	ZW290283	'U' Ring 2.85M	6-1-1	1
5-16	MZ405483	Cam B-1, w/tap	900-206	1	5-33	ML226124	SW. Lever B	900-256	1
5-17	MZ544364	Control Chassis	MU-2001	1	5-34	ZS437545	Hexagon Bolt 4x7, w/washer		2
5-18	ES479485	Slide SW. S-1	25-3-66	2					
5-19	ZS371856	ISO Screw, binding head 3x5		4	5-35x	MZ256814	Rewind Shaft Spacer	M9-124	2

When ordering parts, please describe Parts Number, Serial Number, and Model Number in detail.



FIG. 6 (A) ILLUSTRATION OF MECHANISM ASSEMBLY BLOCK

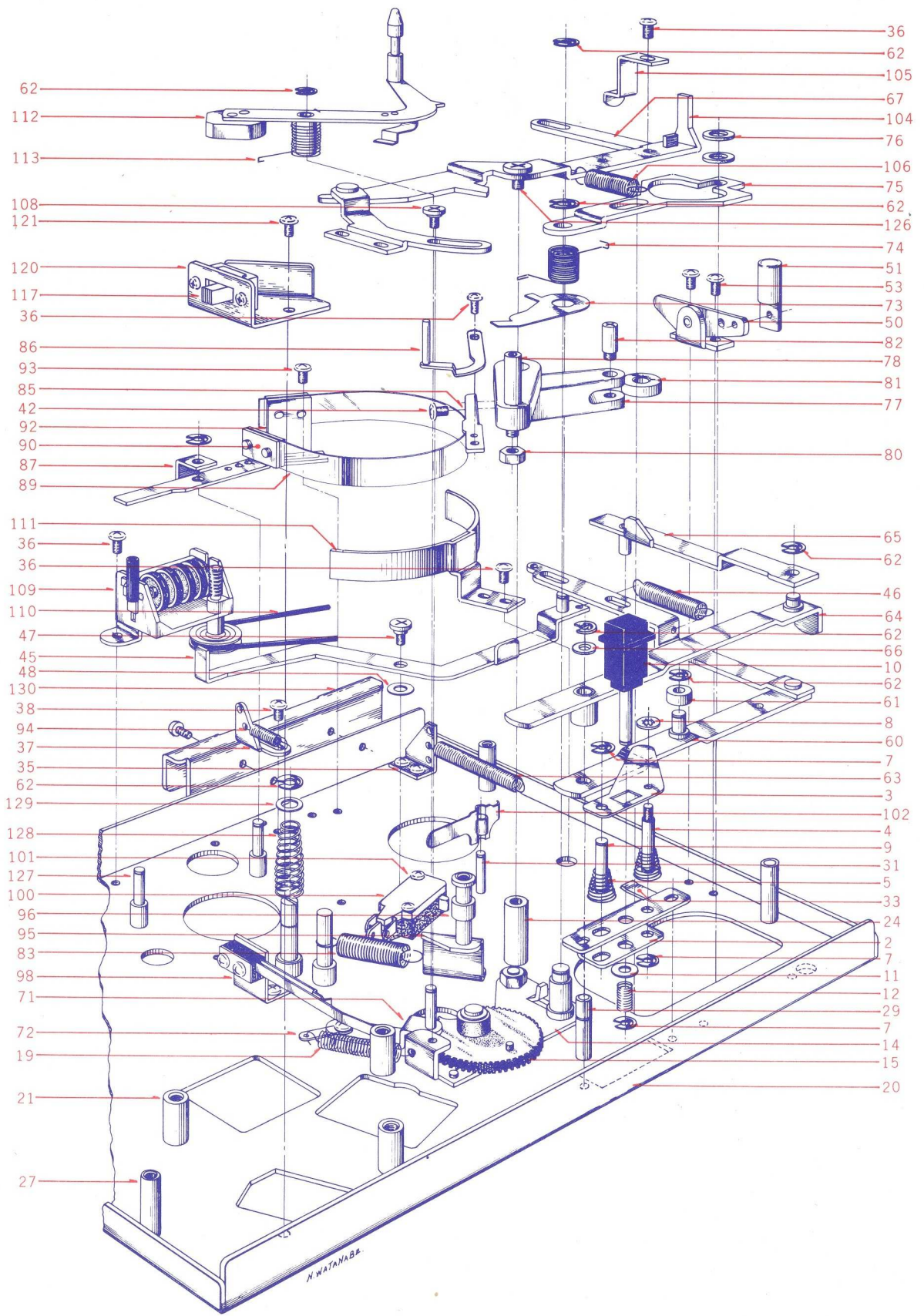
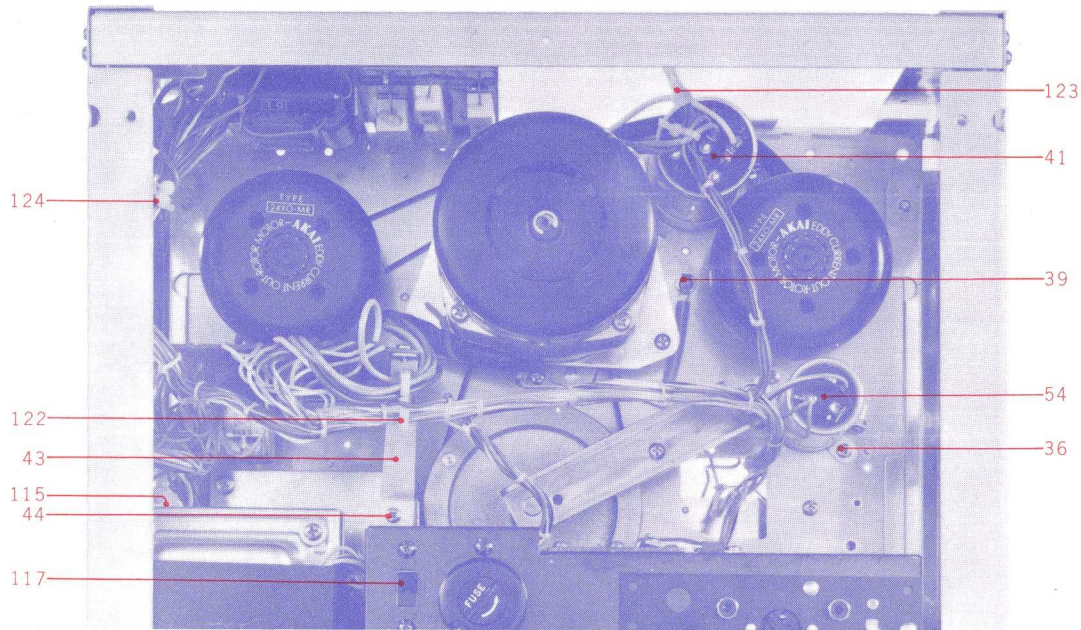

FIG. 6 (B) PHOTO OF MECHANISM ASSEMBLY BLOCK



**MECHANISM ASSEMBLY BLOCK**

Ref. No.	Parts No.	Description	Schematic No.	Q'ty	Ref. No.	Parts No.	Description	Schematic No.	Q'ty
<b>REC. BUTTON BLOCK</b>									
6-1x	BZ558347	REC. Button Block Comp.	MU-1,2	1	6-35	MZ227340	Spring Rack B	900-172	1
6-2	MZ316708	Stopper Table	MR-219	1	6-36	ZS323728	Screw, binding head 3x5		20
6-3	MZ316710	Cam Stopper	MR-220	1	6-37	MZ314605	Spring Rack, MR	MR-104	2
6-4	MS316721	Stopper Shaft	MR-221	1	6-38	ZS425981	Screw, binding head 3x3		4
6-5	ZG316732	Cone Spring	MR-244	2	6-39	ZS413212	Screw, binding head 3x5,		
6-6x	ZW322525	Washer (PBP)D4.1x7x0.2t		1			w/lug		1
6-7	ZW290283	'U' Ring 2.85M	6-1-1	4	6-40x	MZ452496	Cycle Angle (CEE, CSA)	LS-1007	1
6-8	ZW432944	Push Nut 3x10x0.3t		1	6-41	EC520626	MP/C. (3+1) $\mu$ Fx2 250WVAC		
6-9	MS316776	Stopper Shaft B	MR-259	1			(Lug type)	24-9-74	1
6-10	SK543857	REC. Button B	MR-222	1	6-42	ZS413223	Screw, binding head 3x5,		
6-11	ZW419646	Washer (SPC)D4.5x9.8x0.5t		1			w/washer		4
6-12	ZG316765	REC. Button Spring	MR-252	1	6-43	MZ544331	P.C. Board Holder B	MU-1004	1
<b>ECCENTRIC GEAR BLOCK</b>									
6-13x	BZ248027	Eccentric Gear Block Comp.	MU,MC,MS	1	6-44	ZS413155	Screw, binding head 3x6		2
6-14	MZ248016	Eccentric Gear Table, w/shaft	4TR-243	1	6-45	ML314684	Brake Lever C, w/pin	MR-227	1
6-15	MZ248005	Eccentric Gear	4TR-245	1	6-46	ZG314706	Spring IB	MR-115	1
6-16x	ZW861344	Washer (PBP)D6.1x10x0.4t		1	6-47	ZS314717	Graduated Screw, MR	MR-254	1
6-17x	ZW260144	Washer (Nylon)D6.1x10x0.3t		1	6-48	ZW432347	Washer (Luminar)		
6-18x	ZW290283	'U' Ring 2.85M	6-1-1	1			D6.2x13x0.125t		1
6-19	ZG437253	Eccentric Gear Return Spring	MS-2022	1	6-49x	ZW273756	Nut M3		1
<b>MECH. ASSEMBLY BLOCK</b>									
6-20	MZ317340	MR Mech. Frame, w/pin	MR-101	1	6-50	ML226258	Start Lever A, w/lever B-2	4TR-122	1
6-21	MH247533	Head Prop E	100012	3	6-51	SB425777	Start Button D	MS-1002	1
6-22x	ZS413201	Screw, pan head 4x8		2	6-52x	ZW314728	Cotter Pin 1.6x8		1
6-23x	ZS414044	Screw, countersunk head 4x8		1	6-53	ZS425788	Screw, round head 3x4		2
6-24	MS317362	Pinch Roller Arm Shaft	MR-125	1	6-54	EC442056	MP/C. 2+1 $\mu$ F 250WVAC		
6-25x	ZW274026	Spring Washer M5		1			(Lug type)	24-9-61	1
6-26x	ZW413278	Nut M5		1	6-55x	EC536938	MP/C. 2 $\mu$ F 250WVAC		
6-27	MH273295	Mech. Panel Prop, M-9	M9-302	2			(Lug type) (CSA)	24-9-78	1
6-28x	ZS421806	Screw, pan head 3x8		2	6-56x	ZW330412	Adjust Washer (U)		
6-29	MS260515	A Lever Shaft	900-126	1			D4x13x0.13t		1
6-30x	ZW413267	Flange Nut M4		1	6-57x	ZW330423	Adjust Washer (U)		
6-31	MS250536	Micro Lever Shaft	3A-239	1			D4x13x0.25t		1
6-32x	ZW273688	Nut M2.3		1	6-58x	ZW330434	Adjust Washer (U)		
6-33	MZ217697	Pause Lever Stopper Plate	M9-113	1			D4x13x0.5t		1
6-34x	MZ256814	Rewind Shaft Spacer	M9-124	2	6-59x	ZW330445	Adjust Washer (U)		
							D4x13x0.8t		1
					6-60	ML314763	Lever B, MR (w/lever D)	MR-122	1
					6-61	MR314785	Cam Roller D9	MR-237	1
					6-62	ZW290283	'U' Ring 2.85M	6-1-1	5
					6-63	ZG314818	D Lever Spring	MR-114	1
					6-64	ML334506	Lever A, MR (w/metal)	MR-126	1
					6-65	ML314842	C Lever, MR (w/pin)	MR-108	1

When ordering parts, please describe Parts Number, Serial Number, and Model Number in detail.

Ref. No.	Parts No.	Description	Schematic No.	Qty
6-66	ZW419826	Washer (Fiber)D6.2x10x1t		2
6-67	ML314864	IB Lever	MR-111	1
6-68x	ZW259705	Washer (BSP)D4.1x13x1t		1
6-69x	ZS207314	Amp. Lever Set Screw	3A-737	1
6-70x	ZW259885	Washer (PBP)D5.1x10.3x0.1t		1
6-71	MZ549426	AS Lever Prop Table B,		
		w/prop	MC-1214	1
6-72	ZS202116	Screw, binding head 3x5,		
		w/lug		1
6-73	MZ218125	Gear Stopper	4TR-120	1
6-74	ZG226697	Stopper Spring	4TR-121	1
6-75	ML228868	Auto. Mech. Control Lever	4TR-125	1
6-76	ZW260087	Washer (Fiber)D6.1x10x0.5t		1
6-77	ML314932	Pinch Roller Lever, MR	MR-119	1
6-78	MS243404	Pinch Roller Shaft C	4TR-102	1
6-79x	ZW259975	Washer (SUP)D5.1x10.3x0.8t		1
6-80	ZW416698	Nut M4		1
6-81	MR269763	Cam Roller D13	900-154	1
6-82	MS582906	Cam Roller Shaft A-1	7-3-6	1
6-83	ZG455692	Pinch Roller Spring, MS	MS-1015	1
6-84x	ZW314943	Washer (Nylon)D8	MR-113	1
6-85	ML314954	Shifter Lever A	MR-117	1
6-86	ML544353	Shifter Lever, w/pin	MU-1008	1
6-87	ML314976	Brake Lever A (Take-up)	MR-210	1
6-88x	ML396810	Brake Lever B (Supply)	KD-1038	1
6-89	MT314987	Brake Band	MR-213	2
6-90	MZ314998	Brake Band Retaining Plate	MR-212	4
6-91x	ZS417137	Screw, binding head 3x4		6
6-92	MZ315000	Brake Band Support	MR-214	2
6-93	ZS425981	Screw, binding head 3x3		2
6-94	ZG315011	Brake Lever Spring	MR-116	1
6-95	HZ315077	Reverse Guide Base, w/prop	MR-229	1
6-96	HZ315090	Reverse Guide	RD-225	1
6-97x	ZS344463	Set Screw, hexagon socket		
		4x6(cup)		1
6-98	ES546794	Tension SW. Comp.	MU-1012	1
6-99x	ZS427048	Screw, round head 3x3		2
6-100	ES562465	Micro SW. K-1	25-1-26	1
6-101	ZS417148	Screw, binding head 3x15		2
6-102	ML316394	Operation SW. Lever	MR-112	1
6-103x	ZW270088	'E' Ring 1.9M	6-1-9	1
6-104	ML316427	Pause Lever, MR (w/lever B)	MR-233	1
6-105	MZ316451	Pause Stopper, M-7	MH-126	1
6-106	ZG301061	Pause Spring 990A	4TR-128	1
6-107x	ZW260010	Washer (PBP)D6.1x10x0.1t		1
6-108	ZS207314	Amp. Lever Set Screw	3A-737	1
6-109	MC316473	Counter MP-491-17		
		(MD-481-17)	9-1-8	1
6-110	MB230286	Timer Belt D74x1.4(Counter)	3A-120	1
6-111	MZ317406	Brake Band Guide, w/base	MR-120	2
6-112	BL316484	AS Lever Comp.	MR,MS,MC	1
6-113	ZG260706	AS Lever Spring	4TR-118	1
6-114x	MP271170	Pinch Roller, LC D=38	LC-321	1
6-115	EJ450573	Mate-N-Lock Cap Housing		
		9P 1-480277-0	52-1-7	1
6-116x	EJ373623	Pin Contact 61116-1	52-1-1	9
6-117	ES375478	Slide SW. ESD-279DU(black)	25-3-23	2
6-118x	ES479485	Slide SW. S-1 (EC, CSA)	25-3-66	1
6-119x	ZS444273	ISO Screw, binding head 3x4		4
6-120	ML544307	SW. Retaining Plate S	MU-1001	1
6-121	ZS413728	Screw, binding head 3x6,		
		w/washer		1
6-122	EJ510333	Wire Clip 220-JD481610-		
		0104(Nylon)	2-7-17	1
6-123	EJ205975	Cramp Terminal 1-SD	32-1-7	7
6-124	EJ553948	Wire Bundle Holder B	2-35-3	2
6-125x	MZ219576	Cord Retainer D	M9-123	1
6-126	ZS217877	Pause Lever Set Screw	900-136	1
6-127	MH317373	Brake Lever Prop	MR-102	2
6-128	ZG217394	Belt Change Spring B	MH-125	1
6-129	ZW260054	Washer (SUP)D6.1x10x0.25t		1
6-130	SZ547648	Panel Supporting Plate	MU-6027	2
6-131x	ZS339502	Tapping Screw #2 3x5(round)		4

FIG. 7 PHOTO OF SYS. CON. P.C. BOARD (MU-1006)

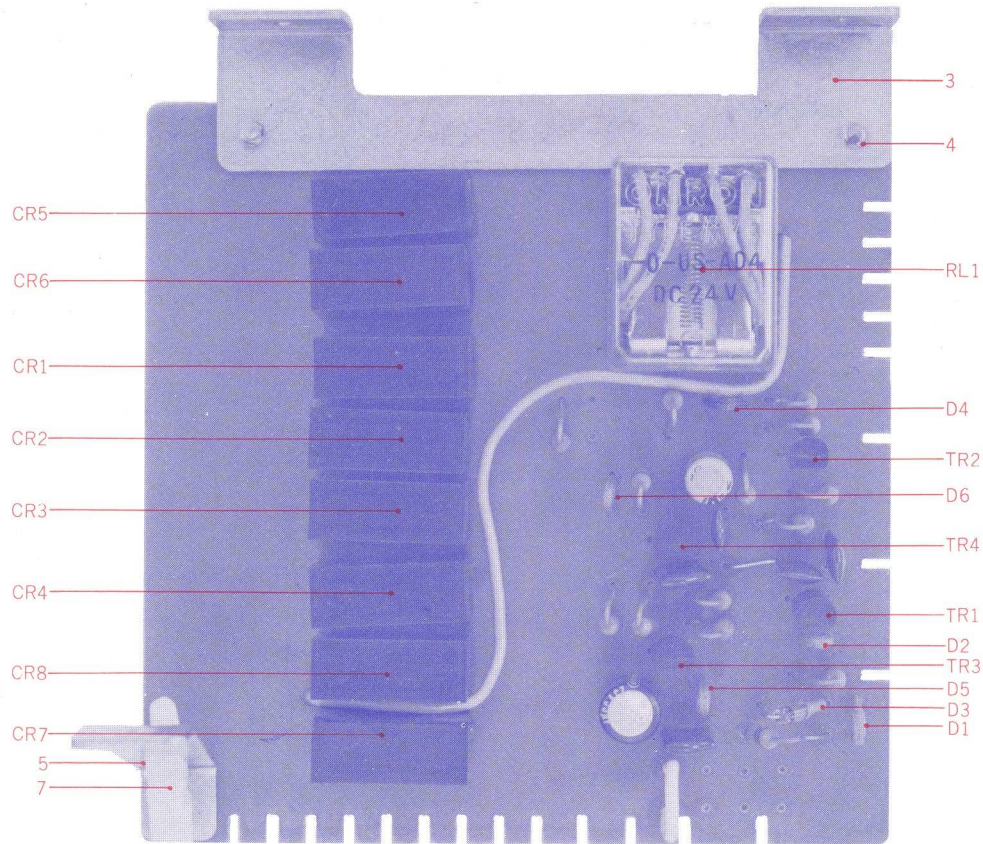

**SYS. CON. P.C. BOARD (MU-1006) BLOCK**

Symbol No.	Parts No.	Description	Q'ty	Symbol No.	Parts No.	Description	Q'ty
7-1x	BA558371	Sys. Con. P.C. Board Comp. (MU-1006)	1	<b>Resistor, Stopper Type</b>			
7-2x	BA570058	Sys. Con. P.C. Board Comp. (MU-1006) (CSA)	1	7-R1	ER211667	Carbon RD1/4 100(J)	1
7-TR1 to 4	ET398711	Transistor 2SC945(Q) (R)	4	7-R2	ER336442	Carbon RD1/4 10k(J)	1
7-D1, 2	ED560913	Silicon Diode 1S2473 VE	2	7-R3	ER212883	Carbon RD1/4 4.7k(J)	1
7-D3	ED219464	Germanium Diode 1N34A	1	7-R4	ER212477	Carbon RD1/4 3.3k(J)	1
7-D4	ED536062	Silicon Diode WG-713	1	7-R5	ER211667	Carbon RD1/4 100(J)	1
7-D5, 6	ED514721	Silicon Diode WG-599	2	7-R5	ER564772	Fuse FRN1/4 100k 200MA (CSA)	1
7-RL1	EP344136	Relay MY4-0-US-AD4 24V	1	7-R6, 7	ER212883	Carbon RD1/4 4.7k(J)	2
7-CR1 to 8	ER450786	Spark Quencher U/L 0.1μ+120Ω 400WV	8	7-R8	ER336442	Carbon RD1/4 10k(J)	1
7-3	EZ544320	P.C. Board Holder A	1	7-R9	ER357456	Carbon RD1/4 2.2k(J)	1
7-4	ZS447772	Tapping Screw #2 3x6(BR)	2	7-R10	ER211757	Carbon RD1/4 100k(J)	1
7-5	MZ544331	P.C. Board Holder B	1	7-R11	ER212264	Carbon RD1/4 22k(J)	1
7-6x	ZS413155	Screw, binding head 3x6	2	7-R12	ER212883	Carbon RD1/4 4.7k(J)	1
7-7	EJ510333	Wire Clip 220-JD481610-0104 (Nylon)	1	7-R13	ER212264	Carbon RD1/4 22k(J)	1
		<b>Capacitor, Vertical Type</b>		7-R14	ER357456	Carbon RD1/4 2.2k(J)	1
7-C1	EC220994	Elect. 10μF 25WV	1				
7-C2	EC383501	Mylar 0.001μF(M) 50WV	1				
7-C3, 4	EC250918	Mylar 0.01μF(M) 50WV	2				
7-C5	EC391498	Mylar 0.022μF(M) 50WV	1				
7-C6	EC220612	Elect. 33μF 25WV	1				
7-C7	EC391498	Mylar 0.022μF(M) 50WV	1				

When ordering parts, please describe Parts Number, Serial Number, and Model Number in detail.

FIG. 8 PHOTO OF CR P.C. BOARD (MU-1007)

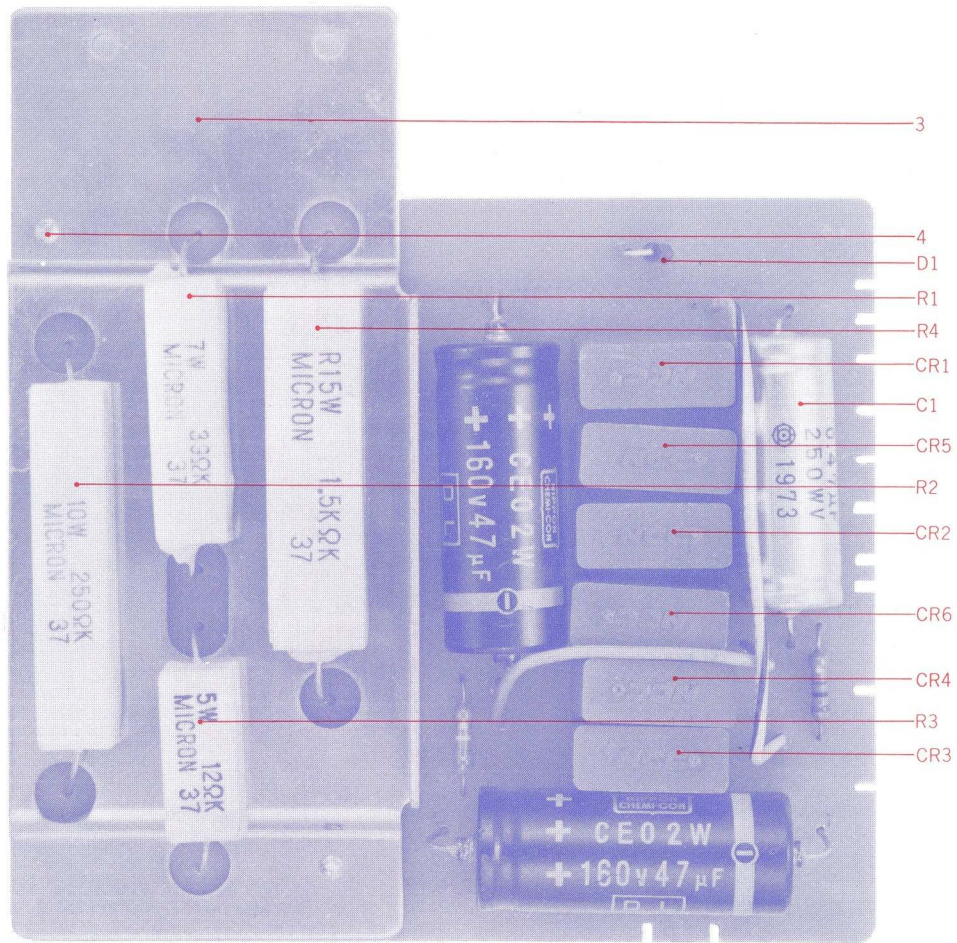

**CR P.C. BOARD (MU-1007) BLOCK**

Symbol No.	Parts No.	Description	Q'ty
8-1x	BA558360	CR P.C. Board Comp. (MU-1007)	1
8-2x	BA574806	CR P.C. Board Comp. (MU-1007) (CSA, EC)	1
8-D1	ED224550	Silicon Diode 10D4	1
8-CR1 to 6	ER450786	Spark Quencher U/L 0.1μ+120Ω 400WV	6
8-CR7	ER570532	Spark Quencher 0.5μ+120Ω 400WV (CSA, EC)	1
8-3	MZ544342	P.C. Board Holder C	1
8-4	ZS447772	Tapping Screw #2 3x6(BR)	2
<b>Capacitor, Tubular Type</b>			
8-C1	EC350987	MP 0.47μF(M) 250VAC	1
8-C2, 3	EC316113	Elect. 47μF 160WV	2
<b>Resistor, Wire-wound Type</b>			
8-R1	ER554883	Cement 7W 39Ω(K)	1
8-R2	ER554861	Cement 10W 250Ω(K)	1
8-R3	ER554905	Cement 5W 12Ω(K)	1
8-R4	ER558461	Cement 15W 1.5k(K) (Metal Ox. Film type)	1
8-R5	ER365016	Carbon RD1/4 220k(J) (Insu. type)	1
8-R6	ER324808	Carbon RD1/4 100(J)(Insu. type)	1

When ordering parts, please describe Parts Number, Serial Number, and Model Number in detail.

FIG. 9 PHOTO OF REC. AMP. P.C. BOARD (MU-5016)

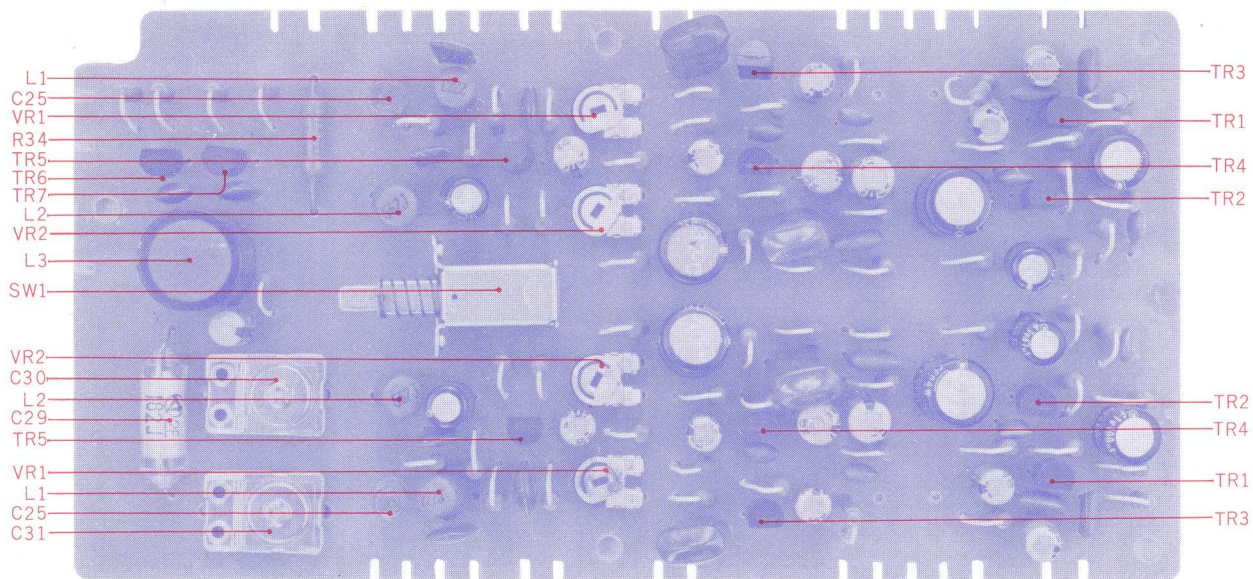

REC. AMP. P.C. BOARD (MU-5016) BLOCK

Symbol No.	Parts No.	Description	Q'ty	Symbol No.	Parts No.	Description	Q'ty
9-1x	BA558404	Rec. Amp. P.C. Board Comp. (MU-5016)	1	<b>Resistor, Stopper Type</b>			
9-TR1,2,3,4	ET517263	Transistor 2SC1312(G) (H)	8	9-R1	ER336442	Carbon RD1/4 10k(J)	2
9-TR5,6,7	ET368021	Transistor 2SC458(B) (C)	4	9-R2	ER362485	Carbon RD1/4 330k(J)	2
9-SW1	ES558191	Slide SW. SPJ-10109	1	9-R3	ER336442	Carbon RD1/4 10k(J)	2
9-VR1	EV464207	Semi-fixed/Vol. V8K4-1 5 kΩ	2	9-R4	ER213300	Carbon RD1/4 680(J)	2
9-VR2	EV520806	Semi-fixed/Vol. V8K4-1 10 kΩ	2	9-R5	ER357570	Carbon RD1/4 150k(J)	2
9-L1	EO458932	Ferri Inductor FL7H 2.2MH(J)	2	9-R6	ER346994	Carbon RD1/4 18k(J)	2
9-L2	EO321254	Ferri Inductor FL7H 5.6MH(J)	2	9-R7	ER343078	Carbon RD1/4 2.7k(J)	2
9-L3	EO383365	OSC. Coil 0T-204	1	9-R8	ER343135	Carbon RD1/4 1.6k(J)	2
<b>Capacitor, Vertical Type</b>				9-R9	ER407316	Carbon RD1/4 24k(J)	2
9-C1	EC290520	VFM 100PF(J) 50WV	2	9-R10	ER357456	Carbon RD1/4 2.2k(J)	2
9-C2	EC320051	Elect. 10μF 16WV	2	9-R11	ER212883	Carbon RD1/4 4.7k(J)	2
9-C3	EC290520	VFM 100PF(J) 50WV	2	9-R12	ER450011	Carbon RD1/4 120k(J)	2
9-C4	EC220364	Elect. 100μF 6.3WV	2	9-R13	ER349942	Carbon RD1/4 8.2k(J)	2
9-C5	EC456322	VFM 22PF(K) 50WV	2	9-R14	ER347038	Carbon RD1/4 270(J)	2
9-C6	EC329771	Elect. 47μF 6.3WV	2	9-R15	ER357491	Carbon RD1/4 82k(J)	2
9-C7	EC320051	Elect. 10μF 16WV	2	9-R16	ER343078	Carbon RD1/4 2.7k(J)	2
9-C8	EC220678	Elect. 47μF 25WV	2	9-R17	ER362441	Carbon RD1/4 1.8k(J)	2
9-C9	EC394918	VFM 33PF(K) 50WV	2	9-R18	ER304402	Carbon RD1/4 470(J)	2
9-C10	EC487394	VFM 47PF(K) 50WV	2	9-R19	ER212264	Carbon RD1/4 22k(J)	2
9-C11	EC320051	Elect. 10μF 16WV	2	9-R20	ER342933	Carbon RD1/4 27k(J)	2
9-C12	EC220678	Elect. 47μF 25WV	2	9-R21	ER357412	Carbon RD1/4 220(J)	2
9-C13	EC329771	Elect. 47μF 6.3WV	2	9-R22	ER342933	Carbon RD1/4 27k(J)	2
9-C14	EC487394	VFM 47PF(K) 50WV	2	9-R23	ER357456	Carbon RD1/4 2.2k(J)	2
9-C15	EC329771	Elect. 47μF 6.3WV	2	9-R24	ER342933	Carbon RD1/4 27k(J)	2
9-C16	EC320051	Elect. 10μF 16WV	2	9-R25	ER336442	Carbon RD1/4 10k(J)	2
9-C17	EC290520	VFM 100PF(J) 50WV	2	9-R26	ER211465	Carbon RD1/4 1k(J)	2
9-C18, 19	EC333562	Mylar 0.18μF(K) 50WV	2	9-R27	ER349784	Carbon RD1/4 390(J)	2
9-C20	EC320051	Elect. 10μF 16WV	2	9-R28	ER380913	Carbon RD1/4 33(J)	2
9-C21	EC250975	Mylar 0.015μF(J) 50WV	2	9-R29	ER336442	Carbon RD1/4 10k(J)	2
9-C22	EC220994	Elect. 10μF 25WV	2	9-R30, 31	ER315944	Carbon RD1/4 3.3(J)	2
9-C23	EC368335	Mylar 0.022μF(J) 50WV	2	9-R32	ER304402	Carbon RD1/4 470(J)	1
9-C24	EC250918	Mylar 0.01μF(M) 50WV	2	9-R33	ER212883	Carbon RD1/4 4.7k(J)	1
9-C25	EC405898	Styrol 470PF(J) 50WV	2	9-R34	ER511288	Metal Oxide Film 1W 180(K)	1
9-C26, 27	EC250841	Mylar 0.01μF(J) 50WV	2	9-R35	ER212477	Carbon RD1/4 3.3k(J)	1
9-C28	EC450055	Elect. 1μF 25WV	1				
9-C29	EC558235	Styrol 1800PF(J) 250WV (Tub. type)	1				
9-C30, 31	EC558202	Trimmer TM-80A	2				

When ordering parts, please describe Parts Number, Serial Number, and Model Number in detail.

FIG. 10 PHOTO OF P.B. AMP. P.C. BOARD (ND-5037)

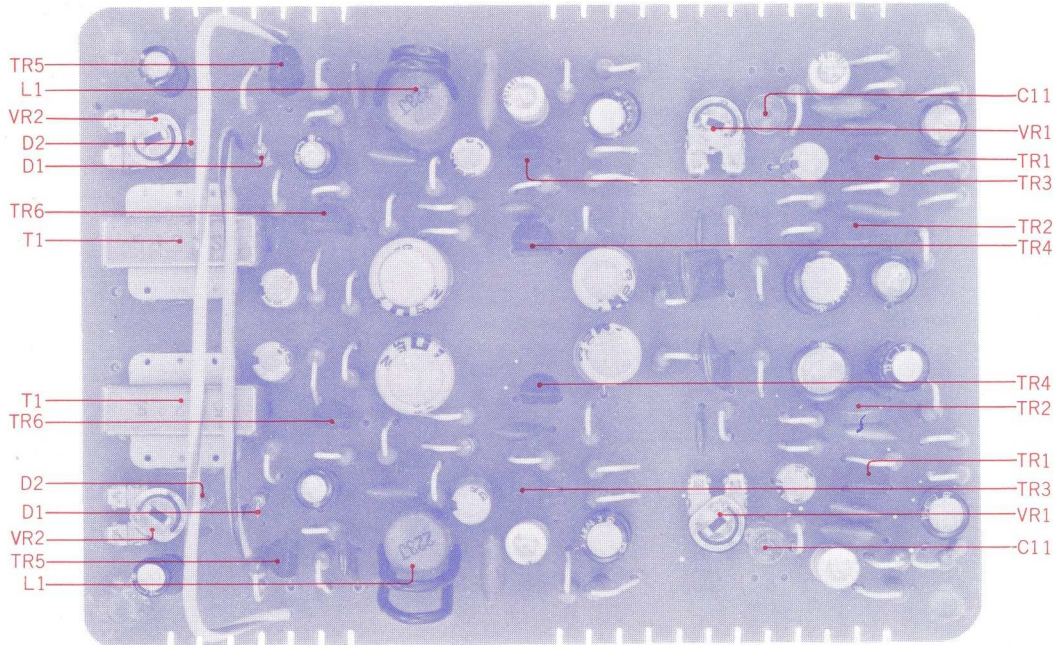

**P.B. AMP. P.C. BOARD (ND-5037) BLOCK**

Symbol No.	Parts No.	Description	Q'ty	Symbol No.	Parts No.	Description	Q'ty
10-1x	BA558415	P.B. Amp. P.C. Board Comp. (ND-5037)	1				
		<b>Capacitor, Vertical Type</b>					
10-C1	EC320051	Elect. 10 $\mu$ F 16WV	2	10-R1	ER362485	Carbon RD1/4 330k(J)	2
10-C2	EC290520	VFM 100PF(J) 50WV	2	10-R2	ER346601	Carbon RD1/4 47k(J)	2
10-C3	EC467133	VFM 68PF(J) 50WV	2	10-R3	ER362485	Carbon RD1/4 330k(J)	2
10-C4	EC329771	Elect. 47 $\mu$ F 6.3WV	2	10-R4	ER336442	Carbon RD1/4 10k(J)	2
10-C5	EC290520	VFM 100PF(J) 50WV	2	10-R5	ER212681	Carbon RD1/4 330(J)	2
10-C6	EC320051	Elect. 10 $\mu$ F 16WV	2	10-R6	ER212264	Carbon RD1/4 22k(J)	2
10-C7	EC320040	Elect. 47 $\mu$ F 16WV	2	10-R7	ER212872	Carbon RD1/4 4.3k(J)	2
10-C8	EC329771	Elect. 47 $\mu$ F 6.3WV	2	10-R8	ER357570	Carbon RD1/4 150k(J)	2
10-C9	EC389485	Mylar 0.018 $\mu$ F(J) 50WV	2	10-R9	ER212477	Carbon RD1/4 3.3k(J)	2
10-C10	EC350875	Mylar 0.001 $\mu$ F(J) 50WV	2	10-R10	ER211757	Carbon RD1/4 100k(J)	2
10-C11	EC435690	Styrol 560PF(J) 50WV	2	10-R11	ER213030	Carbon RD1/4 5.6k(J)	2
10-C12	EC336126	Elect. 47 $\mu$ F 25WV	2	10-R12	ER343078	Carbon RD1/4 2.7k(J)	2
10-C13	EC320051	Elect. 10 $\mu$ F 16WV	2	10-R13	ER346994	Carbon RD1/4 18k(J)	2
10-C14	EC290564	VFM 220PF(K) 50WV	2	10-R14	ER212883	Carbon RD1/4 4.7k(J)	2
10-C15	EC329771	Elect. 47 $\mu$ F 6.3WV	2	10-R15	ER346601	Carbon RD1/4 47k(J)	2
10-C16	EC456322	VFM 22PF(K) 50WV	2	10-R16	ER211465	Carbon RD1/4 1k(J)	2
10-C17	EC336104	Elect. 100 $\mu$ F 6.3WV	2	10-R17	ER212681	Carbon RD1/4 330(J)	2
10-C18	EC320051	Elect. 10 $\mu$ F 16WV	2	10-R18, 19	ER357456	Carbon RD1/4 2.2k(J)	4
10-C19	EC290520	VFM 100PF(J) 50WV	2	10-R20	ER212681	Carbon RD1/4 330(J)	2
10-C20	EC389474	Mylar 0.0015 $\mu$ F(J) 50WV	2	10-R21	ER357491	Carbon RD1/4 82k(J)	2
10-C21	EC450055	Elect. 1 $\mu$ F 25WV	2	10-R22	ER357412	Carbon RD1/4 220(J)	2
10-C22	EC320051	Elect. 10 $\mu$ F 16WV	2	10-R23	ER212264	Carbon RD1/4 22k(J)	2
10-C23	EC450055	Elect. 1 $\mu$ F 25WV	2	10-R24, 25	ER211465	Carbon RD1/4 1k(J)	4
				10-R26	ER429996	Carbon RD1/4 470k(J)	2
				10-R27	ER212264	Carbon RD1/4 22k(J)	2
				10-R28	ER211757	Carbon RD1/4 100k(J)	2
				10-R29	ER350100	Carbon RD1/4 68k(J)	2
				10-R30	ER212883	Carbon RD1/4 4.7k(J)	2

When ordering parts, please describe Parts Number, Serial Number, and Model Number in detail.

FIG. 11 PHOTO OF EQ. P.C. BOARD (MU-5018)

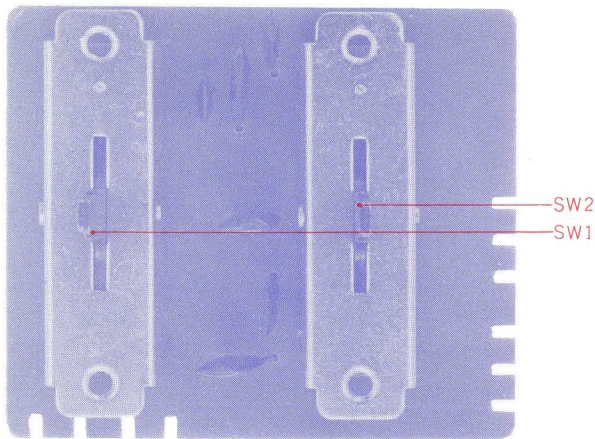

**EQ. P.C. BOARD (MU-5018) BLOCK**

Symbol No.	Parts No.	Description	Q'ty
11-1x	BA558426	EQ. P.C. Board Comp. (MU-5018)	1
11-SW1, 2	ES457514	Lever SW. SQ11 (PVB) 12-4-2 (Black) (M)	2
<b>Capacitor, Vertical Type</b>			
11-C1	EC329883	Mylar 0.0056 $\mu$ F(J) 50WV	2
11-C2	EC311793	Mylar 0.012 $\mu$ F(J) 50WV	2
11-C3	EC329883	Mylar 0.0056 $\mu$ F(J) 50WV	2

When ordering parts, please describe Parts Number, Serial Number, and Model Number in detail.



FIG. 12 PHOTO OF POWER SUPPLY P.C. BOARD (MU-5017)

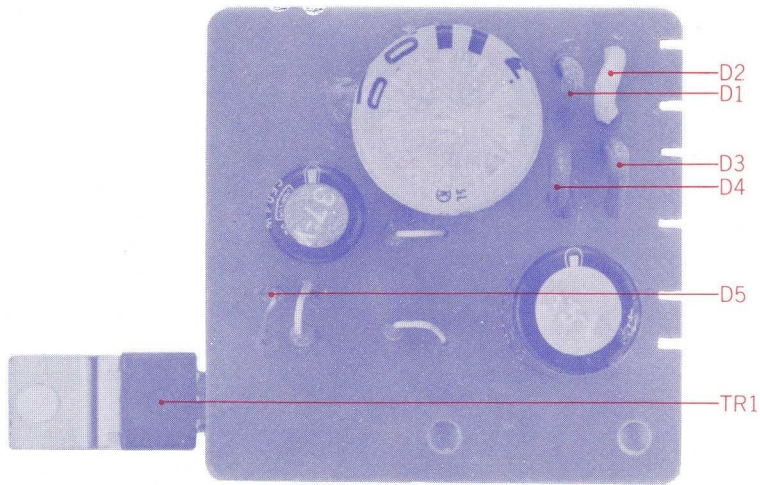

**POWER SUPPLY P.C. BOARD  
(MU-5017) BLOCK**

Symbol No.	Parts No.	Description	Q'ty
12-1x	BA558450	Power Supply P.C. Board Comp. (MU-5017)	1
12-TR1	ET495371	Transistor 2SC1098(L)	1
12-D1,2,3,4	ED494583	Silicon Diode 10D05	4
12-D5	ED511918	Zener Diode WZ-240	1
<b>Capacitor, Vertical Type</b>			
12-C1	EC557651	Elect. 470 $\mu$ F 50WV	1
12-C2	EC220151	Elect. 100 $\mu$ F 25WV	1
12-C3	EC336115	Elect. 220 $\mu$ F 25WV	1
<b>Resistor, Stopper Type</b>			
12-R1	ER306843	Carbon RD1/4 1.2k(J)	1
12-R2	ER211667	Carbon RD1/4 100(J)	1
12-R3	ER430018	Carbon RD1/4 1(J)	1

FIG. 13 PHOTO OF AMPLIFIER ASSEMBLY BLOCK

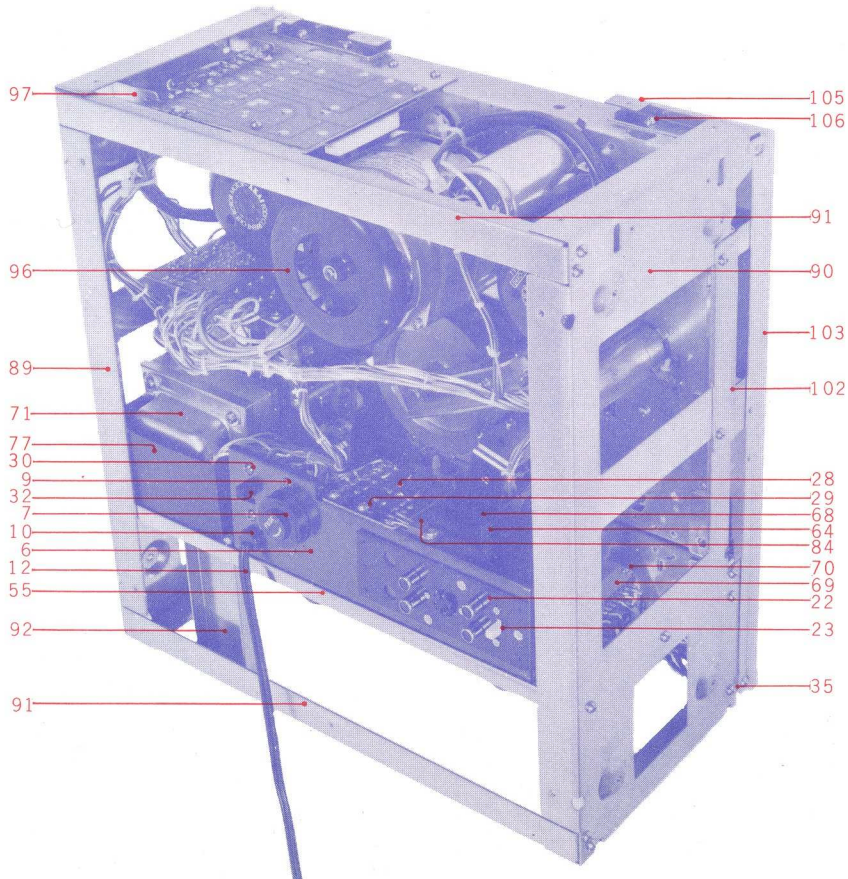
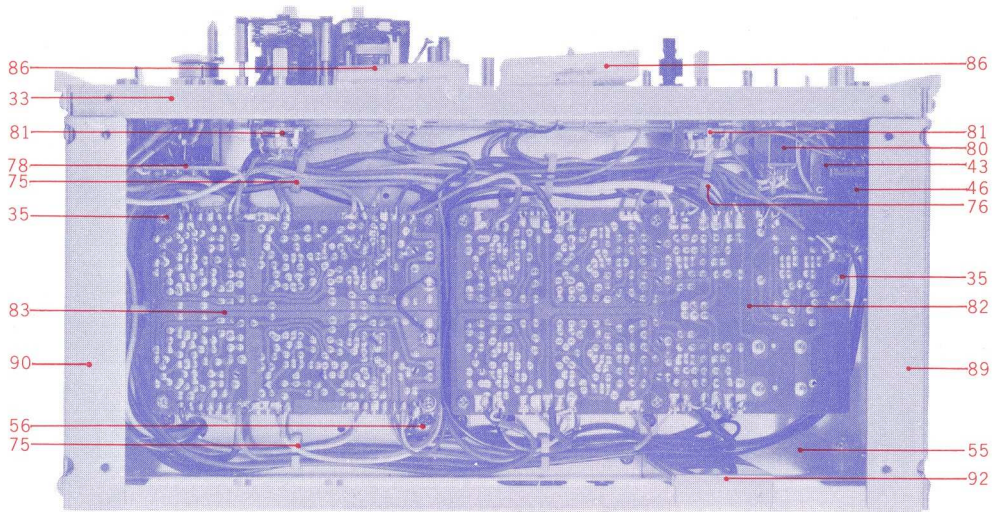
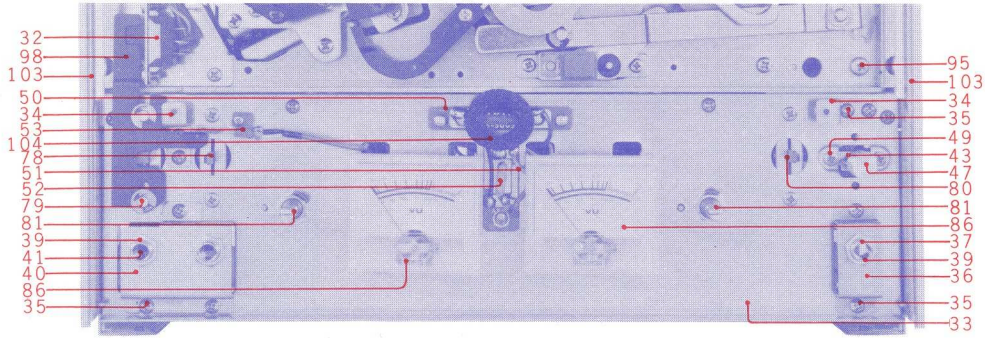

## AMPLIFIER ASSEMBLY BLOCK

Ref. No.	Parts No.	Description	Schematic No.	Q'ty	Ref. No.	Parts No.	Description	Schematic No.	Q'ty
<b>JACK PLATE BLOCK</b>									
13-1x	BZ558437	Jack Plate Block Comp.	MU	1	13-54x	EZ449471	VU Mat	BS-5010	2
13-2x	BZ558448	Jack Plate Block Comp. (3 core)	MU	1	13-55	EZ544680	Amp. Chassis	MU-5001	1
13-3x	BZ570082	Jack Plate Block Comp. (EC)	MU	1	13-56	EZ544375	P.C. Board Bracket	MU-5002	9
13-4x	BZ570093	Jack Plate Block Comp. (CSA)	MU	1	13-57x	ML544432	REC. Lever (Lower)	MU-5010	1
13-5x	BZ570330	Jack Plate Block Comp. (WG)	MU	1	13-58x	MH314280	REC. Lever Pin	MR-528	1
13-6	EZ544511	Jack Plate Bracket	MU-5011	1	13-59x	ZW273892	Toothed Lock Washer M4		1
13-7	EJ233370	Socket (Volt. Selector) S-18010	40-2-3	1	13-60x	ZW416698	Nut M4		1
13-8x	EF558066	Fuse 2A 125V	39-1-47	1	13-61x	ZS314717	Graduated Screw, MR	MR-254	2
13-9	ZS372025	ISO Screw, truss head 3x6 (black)		2	13-62x	ZW273802	Toothed Lock Washer M3		3
13-10	EZ382263	Strain Relief SR-4K-4	2-7-12	1	13-63x	ZW273756	Nut M3		3
13-11x	EZ246936	Strain Relief SR-6W-1 (WG, 3 core)	2-7-8	1	13-64	ML314313	REC. Lever A (Upper)	MR-516	1
13-12	EW540112	AC Cord (CUL) 2.5M	26-3-19	1	13-65x	ZS207314	Amp. Lever Set Screw	3A-737	2
13-13x	EW315448	Australia Cord (3 core)	26-3-11	1	13-66x	ZG314324	REC. Lever Spring A, MR	MR-527	1
13-14x	EW516600	Power Supply Cord, CEE VM-0065 (EC)	26-3-28	1	13-67x	ZW273778	Earth Lug M3		1
13-15x	EW486797	Power Supply Cord, VDE (WG)	26-3-26	1	13-68	ZG227441	Spring C	900-117	1
13-16x	EW524845	AC Cord (J) 2.5M (J)	26-3-31	1	13-69	EJ292961	Multi-jack 10P 500-010-005	31-4-4	1
13-17x	EJ569441	Fuse Holder D (EC)	A0392	1	13-70	ZW558145	Tapping Screw #2 2.6x10		2
13-18x	EF375660	Fuse (T type) 1AT (EC)		1	13-71	BT558167	Power Trans. MUT-1	38-4-237	1
13-19x	EF375715	Fuse (T type) 450MAT (EC)		2	13-72x	BT565931	Power Trans. MUT-2 (CSA)	38-4-265	1
13-20x	EJ569452	Fuse Terminal Plate GX-210D (CSA)	A0383	1	13-73x	BT565920	Power Trans. MUT-3 (EC)	38-4-266	1
13-21x	EF565975	Fuse 800MA 125V	39-1-44	4	13-74x	ZS468112	Tapping Screw #2 4x8(truss) (Nylon)	2-7-18	4
13-22	EJ547198	Jack Plate Comp. MU	MU-5028	1	13-75	EJ514607	Wire Clip 220-JD485210-01		
13-23	ES379045	Slide SW., 6P (small) SJ-0282	25-3-36	1	13-76	EJ510333	Wire Clip 220-JD481610- 0104 (Nylon)	2-7-17	2
13-24x	ER443790	Carbon/R. RD1/4 470k(J) (Insu. type)	35-9-5	2	13-77	EZ461125	Trans. Shield Plate C	MC-5017	1
13-25x	ER345712	Carbon/R. RD1/4 22k(J) (Insu. type)	35-9-5	4	13-78	BA558426	EQ. P.C. Board Comp. (MU-5018)		1
13-26x	ER440921	Carbon/R. RD1/4 27k(J) (Insu. type)	35-9-5	2	13-79	MH544397	Slide Prop	MU-5005	2
13-27x	EJ255093	Lug Plate VB1L1	33-4-1	1	13-80	ES443013	Lever SW. SQ11 12-4-2 (black) (M)	25-12-3	1
13-28	BA558450	Power Supply P.C. Board Comp. (MU-5017)		1	13-81	EV476223	Volume V24N 50 kA	36-2-26	2
13-29	ZS447772	Tapping Screw #2 3x6(BR)		2	13-82	BA558404	REC. Amp. P.C. Board Comp. (MU-5016)		1
13-30	ZS462532	ISO Screw, truss head 3x4		2	13-83	BA558415	P.B. Amp. P.C. Board Comp. (ND-5037)		1
13-31x	ZW273778	Earth Lug M3		1	13-84	ET495371	Transistor 2SC1098(L)	45-1-122	1
13-32	ES375478	Slide SW. ESD-279DU(black)	25-3-23	2	13-85x	ZS323728	Screw, binding head 3x5		1
<b>AMP. ASSEMBLY BLOCK</b>									
13-33	EZ544500	Amp. Plate	MU-5003	1	13-86	EM558180	VU Meter KL-243S-5	46-1-74	2
13-34	EZ544408	Panel Supporting Plate	MU-5006	2	13-87x	EJ300508	Mate-N-Lock Plug Housing 9P 1-480274-O	52-1-7	1
13-35	ZS447772	Tapping Screw #2 3x6(BR)		56	13-88x	EJ373634	Socket Contact 61115-1	52-1-1	9
13-36	EZ544410	Jack Mt. Plate A	MU-5007	1	13-89	EZ544667	Side Plate R	MU-5013	1
13-37	EJ447603	Mic. Jack 3PMJ1	31-2-24	1	13-90	EZ544678	Side Plate L	MU-5013	1
13-38x	ZW272722	Toothed Lock Washer M9 D9.3x13x0.5t		3	13-91	EZ544522	Reinforcement Angle	MU-5012	2
13-39	ZW554624	Nut, E Jack	7-1-56	3	13-92	EZ547661	Amp. Reinforcement Plate	MU-5030	1
13-40	EZ544421	Jack Mt. Plate B	MU-5008	1	13-93x	ZW273767	Earth Lug D3x20L (EC)		1
13-41	EJ391094	Mic. Jack 2PMJ1P	31-2-27	2	13-94x	EJ205975	Cramp Terminal 1-SD (EC, CSA)	32-1-7	1
13-42x	ER364948	Carbon/R. RD1/4 3.3k(J) (Insu. type)	35-9-5	2	13-95	ZS563297	Screw, binding head 4x8, w/spring washer		4
13-43	ES246025	Push SW. SDF1PBP1 (UEH-12BP U/L)	25-5-11	1	13-96	SZ529108	Main Motor Fan	ND-7010	1
13-44x	ES561767	Push SW. NP-285-2 (EC)	25-5-111	1	13-97	SZ544476	P.C. Board Holder D	MU-6016	1
13-45x	ES499972	Push SW. JS-09 (WG)	25-5-67	1	13-98	SZ544386	Coupling Plate	MU-5004	1
13-46	ER450797	Spark Quencher U/L 0.033μ+120Ω 400WV	41-1-34	1	13-99x	ZW558088	Washer D5.2x10.3x0.3t		2
13-47	SK487697	Knob B	CG-2007	1	13-100x	ZW270101	'E' Ring 3M	6-1-9	2
13-48x	SK569632	Knob F (EC)	CG-2007	1	13-101x	SZ544465	Reinforcement Plate L	MU-6015	1
13-49	ZS379405	ISO Screw, binding head 3x6		6	13-102	SZ544691	Reinforcement Plate R	MU-6015	1
13-50	EA449414	Lamp P.C. Board	BS-5005	1	13-103	SE544566	Sash	MU-6011	2
13-51	EA476256	Lamp P.C. Board	MR-5004	1	13-104	UM494267	Lamp Cover	CG-2206	1
13-52	EL295312	Lamp (No. 2) 8V 0.2A	28-2-8	2	13-105	SZ547648	Panel Reinforcement Plate	MU-6027	2
13-53	ES563242	Leaf SW. BSW-1E	25-10-18	1	13-106	ZS339502	Tapping Screw #2 3x5 (round)		4

When ordering parts, please describe Parts Number, Serial Number, and Model Number in detail.

FIG. 14 PHOTO OF FINAL ASSEMBLY BLOCK



## FINAL ASSEMBLY BLOCK

Ref. No.	Parts No.	Description	Schematic No.	Q'ty
14-1	SP544645	Mech. Panel	MU-6001	1
14-2x	SP544656	Mech. Panel B (EC, CSA)	MU-6001	1
14-3	SZ476076	Spin Ring	MR-6003	2
14-4	SE330895	Counter Escutcheon, MR	MR-646	1
14-5	SC544533	Head Cover Base	MU-6003	1
14-6x	ZS413155	Screw, binding head 3x6		6
14-7	ZW408418	Panel Washer	KD-6029	2
14-8	ZS411660	Screw, oval countersunk head 3x6		2
14-9x	ZS447772	Tapping Screw #2 3x6(BR)		4
14-10	SC544544	Head Cover	MU-6004	1
14-11	SM544443	Head Cover Name Plate	MU-6005	1
14-12	SB544454	Direction Button	MU-6006	2
14-13	SP544555	Amp. Panel	MU-6007	1
14-14	SZ457975	Lamp Lens B	55-5012	1
14-15	SE544601	VU Meter Escutcheon	MU-6017	2
14-16x	ZS425788	Screw, round head 3x4		4
14-17	SE544487	SW. Cover	MU-6018	3
14-18	ZW526577	Collar B, Jack	MC-5006	3
14-19	SZ483737	Panel Washer B (black)	KD-6029	2
14-20	ZS425125	Screw, oval countersunk head 3x6(black)		2
14-21x	ZW432347	Washer (Luminar) D6.2x13x0.125t		2
14-22	SK476684	Mech. Knob	LE-6018	2
14-23x	ZS253405	Mech. Knob Screw	7-1-46	2
14-24	SK314100	Pause Knob B	MR-612	1
14-25x	ZS433001	Set Screw, hexagon socket 3x5(cup)		1
14-26	SK425158	Pinch Roller Cap	MS-6020	1
14-27	MP271170	Pinch Roller, LC D=38	LC-321	1
14-28	SK476111	Amp. Knob Comp.	MR-6010	2
14-29	SZ544577	Upper Plate	MU-6012	1
14-30x	ZW461610	Decorative Washer For 3M/M		4
14-31x	ZS482815	Screw, oval countersunk head 3x8		4
14-32	SZ544588	Lower Plate	MU-6012	1
14-33	SA377190	Rubber Foot, LM	LM-404	8
14-34x	ZW419646	Washer (SPC)D4.5x9.8x0.5t		8
14-35x	ZS487776	Screw, truss head 4x18		8
14-36	SK544702	Lever SW. Knob A	MU-6019	3
14-37	BC544590	Side Plate	MU-6013	2
14-38	ZW548010	Spot Facing Washer	MU-6028	8
14-39	ZS558090	Screw, binding head 4x14		8
14-40x	SP544612	Back Plate	MU-6009	1
14-41x	SP544634	Back Plate C (EC)	MU-6009	1
14-42x	SP544623	Back Plate B (CSA)	MU-6009	1
14-43x	ZS498273	Tapping Screw #2 3x8, w/washer		2
14-44x	EF563681	Fuse 1A 250V	39-1-50	1
14-45x	EF558066	Fuse 2A 125V	39-1-47	1
14-46x	EF304626	Fuse ST-4 1A	39-1-28	1

# INDEX

Parts No.	Ref. No. & Symbol No.	Parts No.	Ref. No. & Symbol No.	Parts No.	Ref. No. & Symbol No.	Parts No.	Ref. No. & Symbol No.	Parts No.	Ref. No. & Symbol No.
BA558360	8-1x	EC336126	10-C12	ER212264	7-R13	ER558461	8-R4	HZ541170	1-7
BA558371	7-1x	EC350875	10-C10	ER212264	9-R19	ER564772	7-R5	HZ541181	1-67
BA558404	9-1x	EC350987	8-C1	ER212264	10-R6	ER570532	8-CR7	HZ542092	1-85
BA558404	13-82	EC368335	9-C23	ER212264	10-R23	ES246025	13-43	HZ544206	1-42
BA558415	10-1x	EC383501	7-C2	ER212264	10-R27	ES316923	5-3	HZ544217	1-39
BA558415	13-83	EC389474	10-C20	ER212477	7-R4	ES316934	5-6	HZ544228	1-37
BA558426	11-1x	EC389485	10-C9	ER212477	9-R35	ES317744	1-29	HZ544230	1-36
BA558426	13-78	EC391498	7-C5	ER212477	10-R9	ES375478	6-117	HZ544252	1-11
BA558450	12-1x	EC391498	7-C7	ER212681	10-R5	ES375478	13-32	HZ544263	1-19
BA558450	13-28	EC394918	9-C9	ER212681	10-R17	ES379045	13-23	HZ544274	1-20
BA570058	7-2x	EC405898	9-C25	ER212681	10-R20	ES443013	13-80	HZ544498	1-2
BA574806	8-2x	EC435690	10-C11	ER212872	10-R7	ES457514	11-SW1, 2	HZ547751	1-77
BC544590	14-37	EC442056	6-54	ER212883	7-R3	ES479485	5-18	HZ583176	1-33x
BF476550	4-1x	EC450055	9-C28	ER212883	7-R6, 7	ES479485	6-118x	MB230286	2-33
BH558358	1-1x	EC450055	10-C21	ER212883	7-R12	ES499972	13-45x	MB230286	6-110
BL204480	5-29x	EC450055	10-C23	ER212883	9-R11	ES546794	6-98	MB541012	4-20
BL316484	6-112	EC456322	9-C5	ER212883	9-R33	ES558191	9-SW1	MC316473	6-109
BL555344	3-11x	EC456322	10-C16	ER212883	10-R14	ES561767	13-44x	MH244710	4-8
BM314741	2-1	EC467133	10-C3	ER212883	10-R30	ES562465	6-100	MH247533	6-21
BM563196	3-1	EC487394	9-C10	ER213030	10-R11	ES563242	13-53	MH248343	4-23
BR317384	2-3x	EC487394	9-C14	ER213300	9-R4	ET368021	9-TR5,6,7	MH254160	3-5
BR317395	2-2x	EC520626	6-41	ER304402	9-R18	ET379462	10-TR4,5,6	MH257477	1-17
BS558336	5-1x	EC536938	6-55x	ER304402	9-R32	ET398711	7-TR1 to 4	MH273036	4-13
BT247768	10-T1	EC557651	12-C1	ER306843	12-R1	ET495371	12-TR1	MH273047	4-16
BT558167	13-71	EC558202	9-C30, 31	ER315944	9-R30, 31	ET495371	13-84	MH273295	6-27
BT565920	13-73x	EC558235	9-C29	ER324808	8-R6	ET517263	9-TR1,2,3,4	MH314280	13-58x
BT565931	13-72x	ED219464	7-D3	ER336442	7-R2	ET517263	10-TR1,2,3	MH316304	3-7
BZ248027	6-13x	ED219464	10-D2	ER336442	7-R8	EV464207	9-VR1	MH317046	5-21
BZ558347	6-1x	ED224548	1-8x	ER336442	9-R1	EV464220	10-VR1	MH317373	2-20
BZ558437	13-1x	ED224550	8-D1	ER336442	9-R3	EV476223	13-81	MH317373	6-127
BZ558448	13-2x	ED494583	12-D1,2,3,4	ER336442	9-R25	EV478686	10-VR2	MH544195	1-12
BZ570082	13-3x	ED511918	12-D5	ER336442	9-R29	EV520806	9-VR2	MH544397	13-79
BZ570093	13-4x	ED514721	7-D5, 6	ER336442	10-R4	EW315448	13-13x	MI296245	4-2
BZ570330	13-5x	ED520762	10-D1	ER342933	9-R20	EW486797	13-15x	ML226080	5-30
EA382713	1-28x	ED536062	7-D4	ER342933	9-R22	EW516600	13-14x	ML226124	5-33
EA449414	13-50	ED560913	7-D1, 2	ER342933	9-R24	EW524845	13-16x	ML226258	6-50
EA463206	1-59x	EF304626	14-46x	ER343078	9-R7	EW540112	13-12	ML228868	6-75
EA476256	13-51	EF375660	13-18x	ER343078	9-R16	EZ246936	13-11x	ML314313	13-64
EC220151	12-C2	EF375715	13-19x	ER343078	10-R12	EZ382263	13-10	ML314684	6-45
EC220364	9-C4	EF558066	13-8x	ER343135	9-R8	EZ449471	13-54x	ML314763	6-60
EC220612	7-C6	EF558066	14-45x	ER345712	13-25x	EZ461125	13-77	ML314842	6-65
EC220678	9-C8	EF563681	14-44x	ER346601	10-R2	EZ544320	7-3	ML314864	6-67
EC220678	9-C12	EF565975	13-21x	ER346601	10-R15	EZ544375	13-56	ML314932	6-77
EC220994	7-C1	EJ205975	6-123	ER346994	9-R6	EZ544408	13-34	ML314954	6-85
EC220994	9-C22	EJ205975	13-94x	ER346994	10-R13	EZ544410	13-36	ML314976	2-22
EC250841	9-C26, 27	EJ233370	13-7	ER347038	9-R14	EZ544421	13-40	ML314976	6-87
EC250918	7-C3, 4	EJ255093	13-27x	ER349784	9-R27	EZ544500	13-33	ML316394	6-102
EC250918	9-C24	EJ292961	13-69	ER349942	9-R13	EZ544511	13-6	ML316427	6-104
EC250975	9-C21	EJ300508	13-87x	ER350100	10-R29	EZ544522	13-91	ML334506	6-64
EC290520	9-C1	EJ373623	6-116x	ER357412	9-R21	EZ544667	13-89	ML396810	2-23x
EC290520	9-C3	EJ373634	13-88x	ER357412	10-R22	EZ544678	13-90	ML396810	6-88x
EC290520	9-C17	EJ391094	13-41	ER357456	7-R9	EZ544680	13-55	ML540990	3-12
EC290520	10-C2	EJ447603	13-37	ER357456	7-R14	EZ547661	13-92	ML541001	3-13
EC290520	10-C5	EJ450573	6-115	ER357456	9-R10	HP536501	1-54	ML544285	1-83
EC290520	10-C19	EJ510333	6-122	ER357456	9-R23	HL541157	1-91	ML544307	6-120
EC290564	10-C14	EJ510333	7-7	ER357456	10-R18, 19	HL541168	1-89	ML544353	6-86
EC311793	11-C2	EJ510333	13-76	ER357491	9-R15	HL542687	1-90	ML544432	13-57x
EC316113	8-C2, 3	EJ514607	13-75	ER357491	10-R21	HL544241	1-15	MP271170	6-114x
EC320040	10-C7	EJ547198	13-22	ER357570	9-R5	HR556582	1-34	MP271170	14-27
EC320051	9-C2	EJ553948	6-124	ER357570	10-R8	HZ298012	1-47	MR217203	5-31
EC320051	9-C7	EJ569441	13-17x	ER362441	9-R17	HZ315077	6-95	MR269730	5-12
EC320051	9-C11	EJ569452	13-20x	ER362485	9-R2	HZ315090	6-96	MR269763	6-81
EC320051	9-C16	EL295312	13-52	ER362485	10-R1	HZ317092	1-82	MR314785	6-61
EC320051	9-C20	EM558180	13-86	ER362485	10-R3	HZ317597	1-3	MR317507	2-16
EC320051	10-C1	EO244012	10-L1	ER364948	13-42x	HZ317632	1-23	MR540876	3-3
EC320051	10-C6	EO321254	9-L2	ER365016	8-R5	HZ317632	1-68	MS243404	6-78
EC320051	10-C13	EO383365	9-L3	ER380913	9-R28	HZ317687	1-16	MS250536	6-31
EC320051	10-C18	EO458932	9-L1	ER407316	9-R9	HZ317733	1-27	MS260515	6-29
EC320051	10-C22	EP344136	7-RL1	ER429996	10-R26	HZ318036	1-70	MS316721	6-4
EC329771	9-C6	EP558123	1-9	ER430018	12-R3	HZ318047	1-69	MS316776	6-9
EC329771	9-C13	ER211465	9-R26	ER440921	13-26x	HZ402390	5-2	MS317362	6-24
EC329771	9-C15	ER211465	10-R16	ER443790	13-24x	HZ411017	1-55	MS318093	1-78x
EC329771	10-C4	ER211465	10-R24, 25	ER450011	9-R12	HZ455962	1-22	MS342000	2-6
EC329771	10-C8	ER211667	7-R1	ER450786	7-CR1 to 8	HZ455973	1-24	MS476572	4-3
EC329771	10-C15	ER211667	7-R5	ER450786	8-CR1 to 6	HZ467010	1-73	MS582906	6-82
EC329883	11-C1	ER211667	12-R2	ER450797	13-46	HZ531551	1-46	MT255420	2-5
EC329883	11-C3	ER211757	7-R10	ER511288	9-R34	HZ541102	1-61	MT297663	2-8
EC333562	9-C18, 19	ER211757	10-R10	ER554861	8-R2	HZ541113	1-58	MT314987	2-24
EC336104	10-C17	ER211757	10-R28	ER554883	8-R1	HZ541124	1-56	MT314987	6-89
EC336115	12-C3	ER212264	7-R11	ER554905	8-R3	HZ541135	1-49	MT317441	2-4

# INDEX

Parts No.	Ref. No. & Symbol No.	Parts No.	Ref. No. & Symbol No.	Parts No.	Ref. No. & Symbol No.	Parts No.	Ref. No. & Symbol No.	Parts No.	Ref. No. & Symbol No.
MT317452	2-11	SZ544691	13-102	ZS417148	6-101	ZW290283	2-30		
MT317463	2-10	SZ547648	6-130	ZS417150	3-15	ZW290283	3-18x		
MT325473	2-12x	SZ547648	13-105	ZS421806	6-28x	ZW290283	5-13		
MT436860	2-14	UM494267	13-104	ZS424056	2-18	ZW290283	5-32		
MV248117	1-80	ZG217337	3-14	ZS424056	3-8	ZW290283	6-7		
MV269965	4-21	ZG217394	3-16x	ZS424056	4-22x	ZW290283	6-18x		
MV270066	5-15	ZG217394	6-128	ZS424056	5-24	ZW290283	6-62		
MZ217697	6-33	ZG225516	5-22	ZS425114	1-64	ZW314728	6-52x		
MZ218125	6-73	ZG226697	6-74	ZS425125	14-20	ZW314943	6-84x		
MZ219576	6-125x	ZG227441	13-68	ZS425788	6-53	ZW316800	1-71		
MZ227340	6-35	ZG227564	5-28	ZS425788	14-16x	ZW316800	1-86		
MZ244113	4-9x	ZG255633	2-7	ZS425981	2-28x	ZW317801	1-30x		
MZ248005	6-15	ZG260706	6-113	ZS425981	6-38	ZW317913	1-51		
MZ248016	6-14	ZG301061	6-106	ZS425981	6-93	ZW322525	6-6x		
MZ253113	4-10	ZG314324	13-66x	ZS427026	3-10	ZW326463	1-81x		
MZ254182	3-6	ZG314706	6-46	ZS427037	3-2	ZW330412	6-56x		
MZ256814	5-35x	ZG314818	6-63	ZS427048	6-99x	ZW330423	6-57x		
MZ256814	6-34x	ZG315011	2-29	ZS433001	14-25x	ZW330434	6-58x		
MZ296256	4-6	ZG315011	6-94	ZS437545	5-34	ZW330445	6-59x		
MZ314605	6-37	ZG316732	6-5	ZS439514	4-26x	ZW376402	5-11x		
MZ314897	4-11	ZG316765	6-12	ZS444273	6-119x	ZW392681	4-12		
MZ314998	2-25	ZG317114	1-74	ZS447772	7-4	ZW393232	4-18		
MZ314998	6-90	ZG317496	2-15	ZS447772	8-4	ZW408418	14-7		
MZ315000	2-27	ZG317766	1-32	ZS447772	13-29	ZW413267	6-30x		
MZ315000	6-92	ZG317777	1-66	ZS447772	13-35	ZW413278	6-26x		
MZ316293	3-4	ZG317777	1-93	ZS447772	14-9x	ZW413280	4-17		
MZ316451	6-105	ZG317902	1-50	ZS460440	1-57x	ZW413998	4-19		
MZ316708	6-2	ZG317968	1-62	ZS461395	1-35x	ZW416698	2-21x		
MZ316710	6-3	ZG437253	6-19	ZS462532	13-30	ZW416698	4-24x		
MZ316822	1-84	ZG455692	6-83	ZS464692	1-87	ZW416698	5-25		
MZ316945	5-7	ZG466312	1-63	ZS468112	13-74x	ZW416698	6-80		
MZ316956	5-9	ZG540584	1-41	ZS482815	14-31x	ZW416698	13-60x		
MZ317024	5-23	ZS200384	1-14	ZS487776	14-35x	ZW419646	6-11		
MZ317068	5-27	ZS202116	6-72	ZS498273	14-43x	ZW419646	14-34x		
MZ317340	6-20	ZS203016	3-19	ZS554916	1-25	ZW419826	6-66		
MZ317406	2-32	ZS207314	6-69x	ZS554938	1-48	ZW430863	1-45x		
MZ317406	6-111	ZS207314	6-108	ZS554962	1-72	ZW432347	6-48		
MZ405483	5-16	ZS207314	13-65x	ZS555737	1-10	ZW432347	14-21x		
MZ439525	4-25	ZS217877	6-126	ZS558090	14-39	ZW432944	6-8		
MZ446635	4-7	ZS253405	14-23x	ZS558101	1-95x	ZW447208	4-4		
MZ452496	6-40x	ZS272395	3-9	ZS558134	1-26	ZW461610	14-30x		
MZ544331	6-43	ZS314717	6-47	ZS558257	1-60	ZW526577	14-18		
MZ544331	7-5	ZS314717	13-61x	ZS559045	5-20x	ZW548010	14-38		
MZ544342	8-3	ZS323728	1-6	ZS559056	1-21	ZW554624	13-39		
MZ544364	5-17	ZS323728	2-31x	ZS563297	13-95	ZW554940	1-53		
MZ549426	6-71	ZS323728	5-26x	ZW231805	1-79	ZW558088	13-99x		
SA377190	14-33	ZS323728	6-36	ZW259705	6-68x	ZW558145	13-70		
SB425777	6-51	ZS323728	13-85x	ZW259885	1-75	ZW563218	1-94		
SB544454	14-12	ZS339502	6-131x	ZW259885	6-70x	ZW861344	6-16x		
SC544533	14-5	ZS339502	13-106	ZW259942	5-10x				
SC544544	14-10	ZS344463	6-97x	ZW259975	6-79x				
SE330895	14-4	ZS365973	2-17	ZW260010	6-107x				
SE544487	14-17	ZS371856	5-19	ZW260054	3-17x				
SE544566	13-103	ZS372025	13-9	ZW260054	6-129				
SE544601	14-15	ZS372183	1-31	ZW260087	6-76				
SK314100	14-24	ZS373577	4-5x	ZW260144	6-17x				
SK425158	14-26	ZS379405	13-49	ZW270088	1-18				
SK476111	14-28	ZS384131	1-65	ZW270088	2-9				
SK476684	14-22	ZS396044	1-44	ZW270088	6-103x				
SK487697	13-47	ZS411660	14-8	ZW270101	13-100x				
SK543857	6-10	ZS413155	6-44	ZW270123	1-76				
SK544702	14-36	ZS413155	7-6x	ZW270134	3-21				
SK569632	13-48x	ZS413155	14-6x	ZW272722	13-38x				
SM544443	14-11	ZS413201	4-14	ZW273688	1-88				
SP544555	14-13	ZS413201	5-14	ZW273688	6-32x				
SP544612	14-40x	ZS413201	6-22x	ZW273756	4-27x				
SP544623	14-42x	ZS413212	6-39	ZW273756	5-5x				
SP544634	14-41x	ZS413223	6-42	ZW273756	6-49x				
SP544645	14-1	ZS413728	1-13	ZW273756	13-63x				
SP544656	14-2x	ZS413728	5-8x	ZW273767	13-93x				
SZ457975	14-14	ZS413728	6-121	ZW273778	1-5				
SZ476076	14-3	ZS413741	1-43	ZW273778	2-13x				
SZ483737	14-19	ZS413785	1-40	ZW273778	13-31x				
SZ529108	3-20	ZS413785	2-19	ZW273778	13-67x				
SZ529108	13-96	ZS414033	1-4	ZW273802	5-4x				
SZ544386	13-98	ZS414044	6-23x	ZW273802	13-62x				
SZ544465	13-101x	ZS417137	1-38	ZW273892	13-59x				
SZ544476	13-97	ZS417137	1-92	ZW273914	4-15				
SZ544577	14-29	ZS417137	2-26x	ZW274026	6-25x				
SZ544588	14-32	ZS417137	6-91x	ZW290283	1-52				

---

SECTION 3

**SCHEMATIC DIAGRAM**

1. GX-210D SCHEMATIC DIAGRAM



# PRICE LIST FOR PARTS

## AKAI STEREO TAPE DECK

### MODEL GX-210D



**AKAI AMERICA, LTD.**  
2139 E. DEL AMO BLVD.  
COMPTON, CALIF. 90220

Ref. No. & Symbol No.	Parts No.	Sugg. List Price	Ref. No. & Symbol No.	Parts No.	Sugg. List Price	Ref. No. & Symbol No.	Parts No.	Sugg. List Price	Ref. No. & Symbol No.	Parts No.	Sugg. List Price
<b>MU GX HEAD BLOCK</b>			1-49	HZ541135	.36	2-1	BM314741	64.00	3-8	ZS424056	.18
1-1x	BH558358	144.00	1-50	ZG317902	.06	2-2x	BR317395	10.25	3-9	ZS272395	.06
1-2	HZ544498	1.16	1-51	ZW317913	.06	2-3x	BR317384	10.75	3-10	ZS427026	.18
1-3	HZ317597	1.06	1-52	ZW290283	.18	2-4	MT317441	3.00	<b>BELT CHANGE LEVER BLOCK</b>		
1-4	ZS414033	.18	1-53	ZW554940	.18	2-5	MT255420	.36	3-11x	BL555344	3.00
1-5	ZW273778	.18	1-54	HP536501	98.00	2-6	MS342000	.74	3-12	ML540990	.74
1-6	ZS323728	.18	1-55	HZ411017	2.25	2-7	ZG255633	.18	3-13	ML541001	.12
1-7	HZ541170	.12	1-56	HZ541124	.18	2-8	MT297663	.18	3-14	ZG217337	.06
1-8x	ED224548	.66	1-57x	ZS460440	.18	2-9	ZW270088	.18	3-15	ZS417150	.18
1-9	EP558123	4.00	1-58	HZ541113	.12	2-10	MT317463	.74	3-16x	ZG217394	.06
1-10	ZS555737	.36	1-59x	EA463206	.06	2-11	MT317452	1.16	3-17x	ZW260054	.36
1-11	HZ544252	.24	1-60	ZS558257	.36	2-12x	MT325473	1.16	3-18x	ZW290283	.18
1-12	MH544195	.24	1-61	HZ541102	.36	2-13x	ZW273778	.18	3-19	ZS203016	.18
1-13	ZS413728	.36	1-62	ZG317968	.06	2-14	MT436860	.90	3-20	SZ529108	.52
1-14	ZS200384	.18	1-63	ZG466312	.06	2-15	ZG317496	.06	3-21	ZW270134	.18
1-15	HL544241	.36	1-64	ZS425114	.18	2-16	MR317507	.44	<b>FLYWHEEL BLOCK</b>		
1-16	HZ317687	.06	1-65	ZS384131	.18	2-17	ZS365973	.18	4-1x	BF476550	22.00
1-17	MH257477	.06	1-66	ZG317777	.06	2-18	ZS424056	.18	4-2	MI296245	4.66
1-18	ZW270088	.18	1-67	HZ541181	.44	2-19	ZS413785	.18	4-3	MS476572	.90
1-19	HZ544263	.12	1-68	HZ317632	.06	<b>MECH. ASSEMBLY BLOCK</b>			4-4	ZW447208	.06
1-20	HZ544274	.06	1-69	HZ318047	.66	2-20	MH317373	.30	4-5x	ZS373577	.12
1-21	ZS559056	.18	1-70	HZ318036	.52	2-21x	ZW416698	.18	4-6	MZ296256	2.65
1-22	HZ455962	.52	1-71	ZW316800	.18	2-22	ML314976	.44	4-7	MZ446635	.18
1-23	HZ317632	.06	1-72	ZS554962	.18	2-23x	ML396810	.44	4-8	MH244710	.06
1-24	HZ455973	.52	1-73	HZ467010	.06	2-24	MT314987	.66	4-9x	MZ244113	.06
1-25	ZS549116	.18	1-74	ZG317114	.06	2-25	MZ314998	.06	4-10	MZ253113	.36
1-26	ZS558134	.18	1-75	ZW259885	.36	2-26x	ZS417137	.18	<b>MECH. ASSEMBLY BLOCK</b>		
1-27	HZ317733	.06	1-76	ZW270123	.18	2-27	MZ315000	.06	4-11	MZ314897	.44
1-28x	EA382713	.90	1-77	HZ547751	1.06	2-28x	ZS425981	.18	4-12	ZW392681	.30
1-29	ES317744	1.60	1-78x	MS318093	.66	2-29	ZG315011	.06	4-13	MH273036	.52
1-30x	ZW317801	.30	1-79	ZW231805	.06	2-30	ZW290283	.18	4-14	ZS413201	.18
1-31	ZS372183	.18	1-80	MV248117	3.50	2-31x	ZS323728	.18	4-15	ZW273914	.30
1-32	ZG317766	.06	1-81x	ZW326463	.36	2-32	MZ317406	.66	4-16	MH273047	.66
1-33x	HZ583176	.12	1-82	HZ317092	.36	2-33	MB230286	.98	4-17	ZW413280	.18
1-34	HR556582	121.00	<b>MECH. ASSEMBLY BLOCK</b>			<b>MAIN MOTOR BLOCK</b>			4-18	ZW393232	.30
1-35x	ZS461395	.18	1-83	ML544285	.24	3-1	BM563196	73.00	4-19	ZW413998	.30
1-36	HZ544230	.18	1-84	MZ316822	.06	3-2	ZS427037	.36	4-20	MB541012	.52
1-37	HZ544228	.12	1-85	HZ542092	.36	3-3	MR540876	2.25	4-21	MV269965	.06
1-38	ZS417137	.18	1-86	ZW316800	.18	3-4	MZ316293	1.06	<b>MECH. ASSEMBLY BLOCK</b>		
1-39	HZ544217	.30	1-87	ZS464692	.18	3-5	MH254160	.18	4-12	ZW392681	.30
1-40	ZS413785	.18	1-88	ZW273688	.18	3-6	MZ254182	.18	4-13	MH273036	.52
1-41	ZG540584	.06	1-89	HL541168	.36	3-7	MH316304	.66	4-14	ZS413201	.18
1-42	HZ544206	.74	1-90	HL542687	.36	<b>MAIN MOTOR BLOCK</b>			4-15	ZW273914	.30
1-43	ZS413741	.18	1-91	HL541157	.06	3-1	BM563196	73.00	4-16	MH273047	.66
1-44	ZS396044	.18	1-92	ZS417137	.18	3-2	ZS427037	.36	4-17	ZW413280	.18
1-45x	ZW430863	.18	1-93	ZG317777	.06	3-3	MR540876	2.25	4-18	ZW393232	.30
1-46	HZ531551	.30	1-94	ZW563218	.36	3-4	MZ316293	1.06	4-19	ZW413998	.30
1-47	HZ298012	.30	1-95x	ZS558101	.36	3-5	MH254160	.18	4-20	MB541012	.52
1-48	ZS554938	.18	<b>REEL MOTOR &amp; REEL TABLE BLOCK</b>			3-6	MZ254182	.18	4-21	MV269965	.06

When ordering parts, please describe Parts Number, Serial Number, and Model Number in detail.

Ref. No. & Symbol No.	Parts No.	Sugg. List Price	Ref. No. & Symbol No.	Parts No.	Sugg. List Price	Ref. No. & Symbol No.	Parts No.	Sugg. List Price	Ref. No. & Symbol No.	Parts No.	Sugg. List Price
4-22x	ZS424056	.18	6-14	MZ248016	1.50	<b>MECHANISM ASSEMBLY BLOCK</b>			7-TR1 to 4	ET398711	.74
4-23	MH248343	.06	6-15	MZ248005	.66				7-D1, 2	ED560913	.18
4-24x	ZW416698	.18	6-16x	ZW861344	.30				7-D3	ED219464	.36
4-25	MZ439525	.52	6-17x	ZW260144	.30				7-D4	ED536062	.18
4-26x	ZS439514	.18	6-18x	ZW290283	.18				7-D5, 6	ED514721	.06
4-27x	ZW273756	.18	6-19	ZG437253	.06				7-RL1	EP344136	7.30
<b>SWITCH BLOCK</b>			<b>MECH. ASSEMBLY BLOCK</b>						7-CR1 to 8	ER450786	.98
<b>SWITCH BLOCK</b>			6-20	MZ317340	8.00				7-3	EZ544320	.24
5-1x	BS558336	25.00	6-21	MH247533	.18				7-4	ZS447772	.18
5-2	HZ402390	2.25	6-22x	ZS413201	.18				7-5	MZ544331	.12
5-3	ES316923	2.25	6-23x	ZS414044	.18	7-6x	ZS413155	.18			
5-4x	ZW273802	.30	6-24	MS317362	.66	7-7	EJ510333	.18			
5-5x	ZW273756	.18	6-25x	ZW274026	.30	<b>Capacitor, Vertical Type</b>					
5-6	ES316934	2.25	6-26x	ZW413278	.18	7-C1	EC220994	.30			
5-7	MZ316945	.06	6-27	MH273295	.18	7-C2	EC383501	.18			
5-8x	ZS413728	.36	6-28x	ZS421806	.18	7-C3, 4	EC250918	.18			
5-9	MZ316956	1.16	6-29	MS260515	.36	7-C5	EC391498	.18			
5-10x	ZW259942	.30	6-30x	ZW413267	.18	7-C6	EC220612	.36			
5-11x	ZW376402	.30	6-31	MS250536	.06	7-C7	EC391498	.18			
5-12	MR269730	.06	6-32x	ZW273688	.18	<b>Resistor, Stopper Type</b>					
5-13	ZW290283	.18	6-33	MZ217697	.06	7-R1	ER211667	.12			
5-14	ZS413201	.18	6-34x	MZ256814	.06	7-R2	ER336442	.12			
5-15	MV270066	.06	6-35	MZ227340	.06	7-R3	ER212883	.12			
5-16	MZ405483	.52	6-36	ZS323728	.18	7-R4	ER212477	.12			
5-17	MZ544364	.52	6-37	MZ314605	.06	7-R5	ER211667	.12			
5-18	ES479485	1.06	6-38	ZS425981	.18	7-R5	ER564772	.66			
5-19	ZS371856	.18	6-39	ZS413212	.18	7-R6, 7	ER212883	.12			
5-20x	ZS559045	.36	6-40x	MZ452496	.06	7-R8	ER336442	.12			
5-21	MH317046	.40	6-41	EC520626	6.80	7-R9	ER357456	.12			
5-22	ZG225516	.06	6-42	ZS413223	.36	7-R10	ER211757	.12			
5-23	MZ317024	.06	6-43	MZ544331	.12	7-R11	ER212264	.12			
5-24	ZS424056	.18	6-44	ZS413155	.18	7-R12	ER212883	.12			
5-25	ZW416698	.18	6-45	ML314684	3.50	7-R13	ER212264	.12			
5-26x	ZS323728	.18	6-46	ZG314706	.06	7-R14	ER357456	.12			
5-27	MZ317068	.30	6-47	ZS314717	.06	<b>CR P.C. BOARD (MU-1007) BLOCK</b>					
5-28	ZG227564	.66	6-48	ZW432347	.30	8-1x	BA558360	30.00			
<b>SWITCH LEVER BLOCK</b>			6-49x	ZW273756	.18	8-2x	BA574806	28.00			
5-29x	BL204480	2.25	6-50	ML226258	.36	8-D1	ED224550	.44			
5-30	ML226080	.52	6-51	SB425777	.30	8-CR1 to 6	ER450786	.98			
5-31	MR217203	.06	6-52x	ZW314728	.06	8-CR7	ER570532	3.30			
5-32	ZW290283	.18	6-53	ZS425788	.18	8-3	MZ544342	.66			
5-33	ML226124	.30	6-54	EC442056	3.50	8-4	ZS447772	.18			
5-34	ZS437545	.12	6-55x	EC536938	3.50	<b>Capacitor, Tubular Type</b>					
5-35x	MZ256814	.06	6-56x	ZW330412	.30	8-C1	EC350987	1.06			
<b>MECHANISM ASSEMBLY BLOCK</b>			6-57x	ZW330423	.30	8-C2, 3	EC316113	1.06			
<b>REC. BUTTON BLOCK</b>			6-58x	ZW330434	.30	<b>Resistor, Wire-wound Type</b>					
6-1x	BZ558347	3.50	6-59x	ZW330445	.30	8-R1	FR554883	.44			
6-2	MZ316708	.06	6-60	ML314763	1.80	8-R2	ER554861	.74			
6-3	MZ316710	.30	6-61	MR314785	.06	8-R3	ER554905	.44			
6-4	MS316721	.18	6-62	ZW290283	.18	8-R4	ER558461	.74			
6-5	ZG316732	.06	6-63	ZG314818	.06	8-R5	ER365016	.12			
6-6x	ZW322525	.30	6-64	ML334506	1.16	8-R6	ER324808	.12			
6-7	ZW290283	.18	6-65	ML314842	.66	<b>REC. AMP. P.C. BOARD (MU-5016) BLOCK</b>					
6-8	ZW432944	.18	6-66	ML314826	.30	9-1x	BA558404	72.00			
6-9	MS316776	.06	6-67	ML314864	.06	9-TR1,2,3,4	ET517263	.66			
6-10	SK543857	.44	6-68x	ZW259705	.18	9-TR5,6,7	ET368021	.98			
6-11	ZW419646	.30	6-69x	ZS207314	.06	9-SW1	ES558191	2.80			
6-12	ZG316765	.06	6-70x	ZW259885	.30	<b>SYS. CON. P.C. BOARD (MU-1006) BLOCK</b>					
<b>ECCENTRIC GEAR BLOCK</b>			6-71	MZ549426	.06	7-1x	BA558371	40.00			
6-13x	BZ248027	3.50	6-72	ZS202116	.18	7-2x	BA570058	41.00			
			6-73	MZ218125	.30						
			6-74	ZG226697	.18						

Ref. No. & Symbol No.	Parts No.	Sugg. List Price	Ref. No. & Symbol No.	Parts No.	Sugg. List Price	Ref. No. & Symbol No.	Parts No.	Sugg. List Price	Ref. No. & Symbol No.	Parts No.	Sugg. List Price
9-VR1	EV464207	.18	10-1x	BA558415	62.00	<b>POWER SUPPLY P.C. BOARD (MU-5017) BLOCK</b>			13-35	ZS447772	.18
9-VR2	EV520806	.36	10-TR1,2,3	ET517263	.66	12-1x	BA558450	12.80	13-36	EZ544410	.06
9-L1	EO458932	.36	10-TR4,5,6	ET379462	.74	12-TR1	ET495371	1.50	13-37	EJ447603	.80
9-L2	EO321254	.36	10-D1	ED520762	.52	12-D1,2,3,4	ED494583	.90	13-38x	ZW272722	.36
9-L3	EO383365	1.30	10-D2	ED219464	.36	12-D5	ED511918	.66	13-39	ZW554624	.06
<b>Capacitor, Vertical Type</b>			10-T1	BT247768	.90	<b>Capacitor, Vertical Type</b>			13-40	EZ544421	.30
9-C1	EC290520	.12	10-L1	EO244012	.66	10-C1	EC320051	.30	13-41	EJ391094	.80
9-C2	EC320051	.30	10-VR1	EV464220	.18	10-C2	EC290520	.12	13-42x	ER364948	.12
9-C3	EC290520	.12	10-VR2	EV478686	.18	10-C3	EC467133	.06	13-43	ES246025	2.00
9-C4	EC220364	.36	<b>Capacitor, Vertical Type</b>			10-C4	EC329771	.30	<b>AMPLIFIER ASSEMBLY BLOCK</b>		
9-C5	EC456322	.18	10-C5	EC290520	.06	10-C5	EC290520	.06	13-44x	ES561767	4.00
9-C6	EC329771	.30	10-C6	EC320051	.30	10-C6	EC320051	.30	13-45x	ES499972	2.80
9-C7	EC320051	.30	10-C7	EC320040	.36	10-C7	EC320040	.36	13-46	ER450797	.98
9-C8	EC220678	.36	10-C8	EC329771	.30	10-C8	EC329771	.30	13-47	SK487697	.66
9-C9	EC394918	.06	10-C9	EC389485	.36	10-C9	EC389485	.36	13-48x	SK569632	.66
9-C10	EC487394	.06	10-C10	EC350875	.36	10-C10	EC350875	.36	13-49	ZS379405	.18
9-C11	EC320051	.30	10-C11	EC435690	.18	10-C11	EC435690	.18	13-50	EA449414	.12
9-C12	EC220678	.36	10-C12	EC336126	.36	10-C12	EC336126	.36	13-51	EA476256	.18
9-C13	EC329771	.30	10-C13	EC320051	.30	10-C13	EC320051	.30	13-52	EL295312	.66
9-C14	EC487394	.06	10-C14	EC290564	.12	10-C14	EC290564	.12	13-53	ES563242	.66
9-C15	EC329771	.30	10-C15	EC329771	.30	10-C15	EC329771	.30	13-54x	EZ449471	.06
9-C16	EC320051	.30	10-C16	EC456322	.18	10-C16	EC456322	.18	13-55	EZ544680	2.80
9-C17	EC290520	.12	10-C17	EC336104	.36	10-C17	EC336104	.36	13-56	EZ544375	.06
9-C18, 19	EC333562	1.30	10-C18	EC320051	.30	10-C18	EC320051	.30	13-57x	ML544432	.30
9-C20	EC320051	.30	10-C19	EC290520	.12	10-C19	EC290520	.12	13-58x	MH314280	.18
9-C21	EC250975	.36	10-C20	EC389474	.36	10-C20	EC389474	.36	13-59x	ZW273892	.36
9-C22	EC220994	.30	10-C21	EC450055	.30	10-C21	EC450055	.30	13-60x	ZW416698	.18
9-C23	EC368335	.44	10-C22	EC320051	.30	10-C22	EC320051	.30	13-61x	ZS314717	.06
9-C24	EC250918	.18	10-C23	EC450055	.30	10-C23	EC450055	.30	13-62x	ZW273802	.36
9-C25	EC405898	.30	<b>Resistor, Stopper Type</b>			10-R1	ER362485	.12	13-63x	ZW273756	.18
9-C26, 27	EC250841	.36	10-R2	ER346601	.12	10-R2	ER346601	.12	13-64	ML314313	.36
9-C28	EC450055	.30	10-R3	ER362485	.12	10-R3	ER362485	.12	13-65x	ZS207314	.06
9-C29	EC558235	.30	10-R4	ER336442	.12	10-R4	ER336442	.12	13-66x	ZG314324	.06
9-C30, 31	EC558202	.52	10-R5	ER212681	.12	10-R5	ER212681	.12	13-67x	ZW273778	.18
<b>Resistor, Stopper Type</b>			10-R6	ER212264	.12	10-R6	ER212264	.12	13-68	ZG227441	.06
9-R1	ER336442	.12	10-R7	ER212872	.12	10-R7	ER212872	.12	13-69	EJ292961	1.30
9-R2	ER362485	.12	10-R8	ER357570	.12	10-R8	ER357570	.12	13-70	ZW558145	.18
9-R3	ER336442	.12	10-R9	ER212477	.12	10-R9	ER212477	.12	13-71	BT558167	20.00
9-R4	ER213300	.12	10-R10	ER211757	.12	10-R10	ER211757	.12	13-72	BT565931	32.00
9-R5	ER357570	.12	10-R11	ER213030	.12	10-R11	ER213030	.12	13-73x	BT565920	36.00
9-R6	ER346994	.12	10-R12	ER343078	.12	10-R12	ER343078	.12	13-74x	ZS468112	.18
9-R7	ER343078	.12	10-R13	ER346994	.12	10-R13	ER346994	.12	13-75	EJ514607	.18
9-R8	ER343135	.12	10-R14	ER212883	.12	10-R14	ER212883	.12	13-76	EJ510333	.18
9-R9	ER407316	.12	10-R15	ER346601	.12	10-R15	ER346601	.12	13-77	EZ461125	2.00
9-R10	ER357456	.12	10-R16	ER211465	.12	10-R16	ER211465	.12	13-78	BA558426	11.16
9-R11	ER212883	.12	10-R17	ER212681	.12	10-R17	ER212681	.12	13-79	MH544397	.06
9-R12	ER450011	.12	10-R18, 19	ER357456	.12	10-R18, 19	ER357456	.12	13-80	ES443013	1.06
9-R13	ER349942	.12	10-R20	ER212681	.12	10-R20	ER212681	.12	13-81	EV476223	.80
9-R14	ER347038	.12	10-R21	ER357491	.12	10-R21	ER357491	.12	13-82	BA558404	72.00
9-R15	ER357491	.12	10-R22	ER357412	.12	10-R22	ER357412	.12	13-83	BA558415	62.00
9-R16	ER343078	.12	10-R23	ER212264	.12	10-R23	ER212264	.12	13-84	ET495371	1.50
9-R17	ER362441	.12	10-R24, 25	ER211465	.12	10-R24, 25	ER211465	.12	13-85x	ZS323728	.18
9-R18	ER304402	.12	10-R26	ER429996	.12	10-R26	ER429996	.12	13-86	EM558180	5.80
9-R19	ER212264	.12	10-R27	ER212264	.12	10-R27	ER212264	.12	13-87x	EJ300508	1.30
9-R20	ER342933	.12	10-R28	ER211757	.12	10-R28	ER211757	.12	13-88x	EJ373634	.06
9-R21	ER357412	.12	10-R29	ER350100	.12	10-R29	ER350100	.12	13-89	EZ544667	4.00
9-R22	ER342933	.12	10-R30	ER212883	.12	10-R30	ER212883	.12	13-90	EZ544678	4.06
9-R23	ER357456	.12	<b>EQ. P.C. BOARD (MU-5018) BLOCK</b>			11-1x	BA558426	11.00	13-91	EZ544522	.98
9-R24	ER342933	.12	11-SW1, 2	ES45751	1.30	11-SW1, 2	ES45751	1.30	13-92	EZ547661	.52
9-R25	ER336442	.12	<b>Capacitor, Vertical Type</b>			11-C1	EC329883	.36	13-93x	ZW273767	.18
9-R26	ER211465	.12	11-C1	EC329883	.36	11-C2	EC311793	.36	<b>AMP. ASSEMBLY BLOCK</b>		
9-R27	ER349784	.12	11-C2	EC311793	.36	11-C3	EC329883	.36	13-33	EZ544500	1.80
9-R28	ER380913	.12	<b>Capacitor, Vertical Type</b>			13-34	EZ544408	.06			
9-R29	ER336442	.12	11-C1	EC329883	.36						
9-R30, 31	ER315944	.12	11-C2	EC311793	.36						
9-R32	ER304402	.12	11-C3	EC329883	.36						
9-R33	ER212883	.12									
9-R34	ER511288	.18									
9-R35	ER212477	.12									
<b>P.B. AMP. P.C. BOARD (ND-5037) BLOCK</b>											

When ordering parts, please describe Parts Number, Serial Number, and Model Number in detail.

Ref. No. & Symbol No.	Parts No.	Sugg. List Price	Ref. No. & Symbol No.	Parts No.	Sugg. List Price	Ref. No. & Symbol No.	Parts No.	Sugg. List Price	Ref. No. & Symbol No.	Parts No.	Sugg. List Price
13-94x	EJ205975	.06									
13-95	ZS563297	.36									
13-96	SZ529108	.52									
13-97	SZ544476	.18									
13-98	SZ544386	.24									
13-99x	ZW558088	.36									
13-100x	ZW270101	.18									
13-101x	SZ544465	.66									
13-102	SZ544691	.66									
13-103	SE544566	1.40									
13-104	UM494267	.30									
13-105	SZ547648	.24									
13-106	ZS339502	.18									
<b>FINAL ASSEMBLY BLOCK</b>											
14-1	SP544645	30.00									
14-2x	SP544656	11.30									
14-3	SZ476076	1.16									
14-4	SE330895	1.30									
14-5	SC544533	1.60									
14-6x	ZS413155	.18									
14-7	ZW408418	.18									
14-8	ZS411660	.18									
14-9x	ZS447772	.18									
14-10	SC544544	2.50									
14-11	SM544443	4.06									
14-12	SB544454	.24									
14-13	SP544555	6.30									
14-14	SZ457975	.06									
14-15	SE544601	.90									
14-16x	ZS425788	.18									
14-17	SE544487	.36									
14-18	ZW526577	.18									
14-19	SZ483737	.12									
14-20	ZS425125	.18									
14-21x	ZW432347	.36									
14-22	SK476684	1.16									
14-23x	ZS253405	.18									
14-24	SK314100	.88									
14-25x	ZS433001	.12									
14-26	SK425158	1.16									
14-27	MP271170	2.50									
14-28	SK476111	1.20									
14-29	SZ544577	6.50									
14-30x	ZW461610	.18									
14-31x	ZS482815	.18									
14-32	SZ544588	6.50									
14-33	SA377190	.30									
14-34x	ZW419646	.36									
14-35x	ZS487776	.18									
14-36	SK544702	.52									
14-37	BC544590	8.30									
14-38	ZW548010	.12									
14-39	ZS558090	.18									
14-40x	SP544612	1.80									
14-41x	SP544634	1.80									
14-42x	SP544623	1.80									
14-43x	ZS498273	.36									
14-44x	EF563681	.24									
14-45x	EF558066	.36									
14-46x	EF304626	.66									

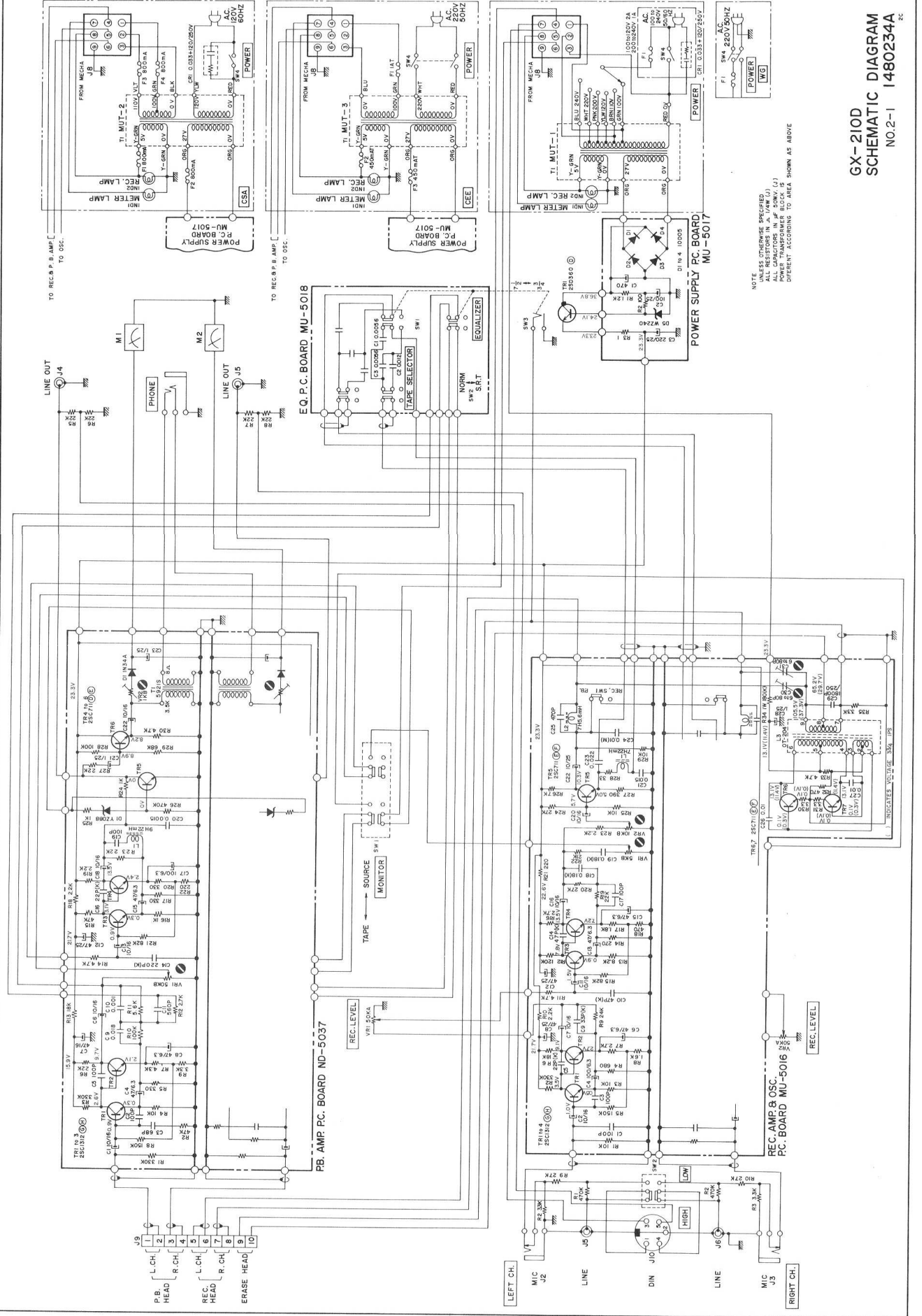

**GX-210D  
SCHEMATIC DIAGRAM  
NO.2-1 1480234A**

NOTE:  
ALL RESISTORS IN A TANK (J)  
DIFFERENT ACCORDING TO AREA SHOWN AS ABOVE

