

MINOLTA

SPOTMETER F

E OWNER'S MANUAL

F MODE D'EMPLOI



MINOLTA SPOTMETER F

Minolta's Spotmeter F is designed specifically for professionals and advanced amateurs and enables precise 1° spot measurements of both ambient and flash light. A full range of exposure information is shown in digital and analog form on external and viewfinder displays.

Besides enabling accurate readings of mid-tone areas, the Spotmeter F can automatically calculate the correct exposure for highlight and shadow areas, as well calculate the average exposure from two readings. To monitor contrast and lighting conditions, the relative brightness of various parts of the scene can be quickly checked while looking through the viewfinder.

The Spotmeter F uses advanced micro-electronic circuitry to assure the highest possible accuracy and reliability. And its low power consumption permits a single, inexpensive AA-size penlight battery to provide thousands of readings.

To obtain the best results and to get maximum use from your Minolta Spotmeter F, please read this manual thoroughly.

TABLE OF CONTENTS

PREPARATION

NAMES OF PARTS	2
INSTALLING THE BATTERY	6
ADJUSTING THE EYEPIECE	8
DISPLAYS	
External digital display	10
Analog display	11
Viewfinder display	12
Over-range and under-range warnings	13
SETTING THE FILM SPEED	14
SETTING THE SHUTTER SPEED	16
SELECTING FNo./EV DISPLAY MODE.	18

OPERATION

GENERAL INFORMATION	20
Mid-tone readings	21
Ambient light measurements	22
Flash measurements	24
EXPOSURE CALCULATION MODES	26
Using the memory function	28
Highlight readings	30
Shadow readings	32
Average readings	34
MONITORING THE LIGHTING CONDITIONS	
Checking differences in brightness	36
Taking brightness-difference reading	37
Determining contrast ratios	39
Luminance measurements	40
CINE MEASUREMENTS	42
CALIBRATION	43
CARE AND STORAGE	44
TECHNICAL DETAILS	45

NAME OF PARTS

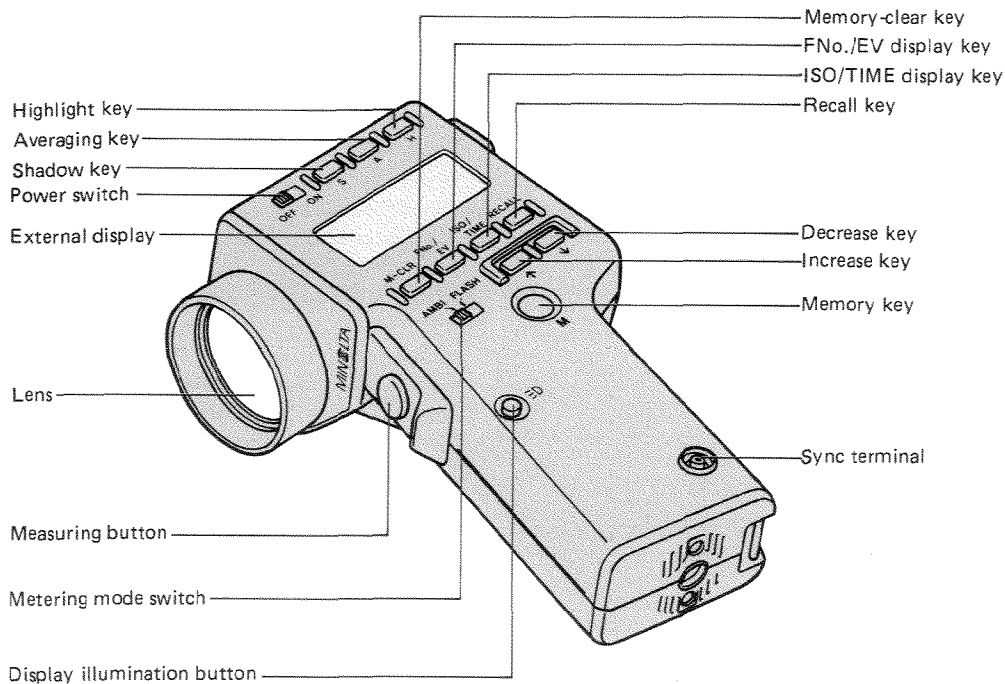

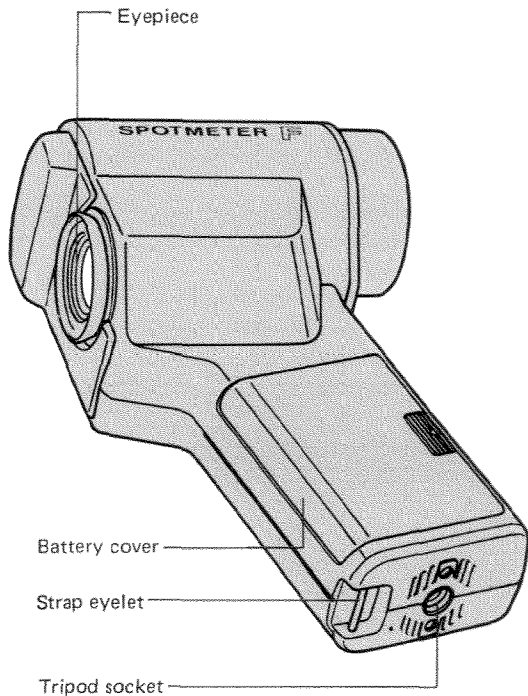

Power switch

Use to switch off the meter to prevent battery drain from accidental readings. Even when switched off, the meter retains the film-speed and shutter-speed settings, along with any memorized/calculated exposure readings.

Shadow key

To bias exposure for a dark shadow area, measure the dark area, then press shadow key. The meter will automatically calculate exposure setting to correctly reproduce shadow areas of scene.

Averaging key

To calculate the average exposure of a scene, measure and memorize readings for both bright and dark areas, then press averaging key. The meter will automatically calculate a median exposure point.

Highlight key

To bias exposure for bright, highlight areas, measure the bright area, then press highlight key. The meter will automatically calculate exposure setting to correctly reproduce highlight areas of scene.

Lens

Fixed focus for readings from about 1.3 meters to infinity.

External display

Refer to page 10.

Measuring button

Press to make an exposure reading. In ambient mode, meter will make continuous readings when button is held in. In flash mode, pressing button triggers flash unit that has been connected to meter's sync terminal.

Memory clear key

Press to clear any memorized readings.

FNo./EV key

Press to select either f-number (FNo.) or exposure value (EV) digital display.

ISO/TIME key

Press to display or select film-speed settings from ISO 12 to 6400 or shutter-speed settings from 1/8000 sec. to 30 min. (plus 1/50 sec. cine setting) in ambient mode and 1/1000 sec. to 1 sec. in flash mode.

Recall key

Press to recall memorized exposure readings to the digital display.

Metering mode switch

Set to "AMBI" mode for ambient light readings. Set to "FLASH" mode for flash readings. Memorized and displayed readings are cleared when the switch is moved to either setting.

Increase and decrease keys

When "TIME" is displayed, the shutter speed is changed by one stop each time a key is pressed. When "ISO" is displayed, these keys are used to change the film-speed setting in 1/3-stop increments. Settings change continuously when a key is held down.

Eyepiece

Built-in eyepiece is adjustable from -2.5 to $+1.2$ diopters.

Memory key

Press to enter exposure reading into memory. Up to two readings can be stored, and will remain displayed on the analog scale.

Display illumination button

Press to illuminate viewfinder display for viewing digital readout in low light.

Sync terminal

To take flash readings, insert flash's sync cord into sync terminal. Terminal is threaded to secure optional Sync Cord II.

Battery cover

Meter is powered by one AA-size penlight battery.

Tripod socket

Standard $1/4-20$ thread matches most tripod-mounting screws.

Strap eyelet

Attach neckstrap as shown here.

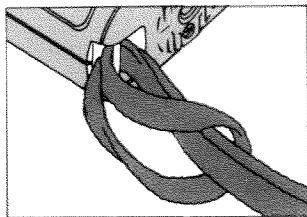

Measuring-level adjustment screw

Use to re-calibrate the meter reading to match that of another meter.

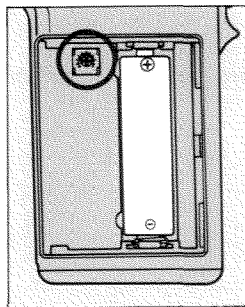

INSTALLING THE BATTERY

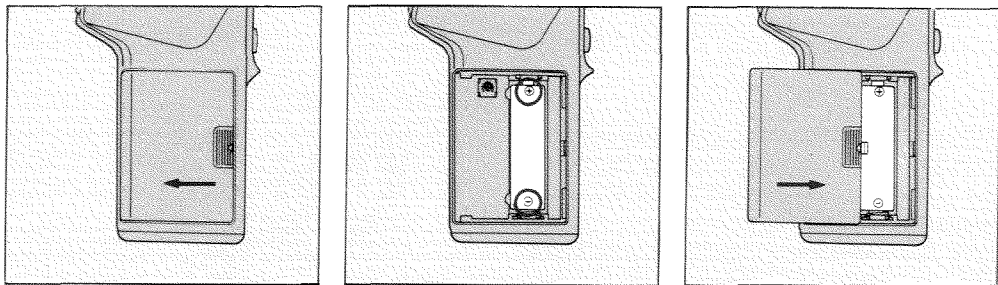

The Spotmeter F is powered by a single AA-size battery. A 1.5-volt alkaline-manganese or carbon-zinc battery or 1.2-volt nickel-cadmium battery can be used. To install the battery:

1. Check that the power switch is set to "OFF".
2. Remove the battery cover by pressing it down and sliding it to the left.

3. Insert the battery, positioning it as marked inside the battery chamber.
4. Replace the cover and slide it back into its original position.

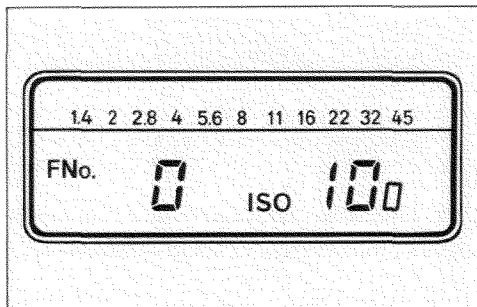

5. Switch on the power. The display shown above should appear.

Automatic battery check

Battery power is automatically monitored whenever a measurement is taken. When battery power drops below minimum requirements, the meter's display will start blinking. If the battery is completely exhausted, no display will appear when the meter is switched on. To replace the battery:

1. Switch off the meter.
2. Open the battery cover and remove the battery.
3. Wait about five seconds for the meter's internal memory to clear itself, then insert a fresh battery.

NOTE

- If the battery is not installed properly, the meter will not operate.
- To prevent accidental measuring, switch off the meter when you are finished using it.
- If the meter will not be used for two weeks or more, the battery should be removed.

ADJUSTING THE EYEPIECE

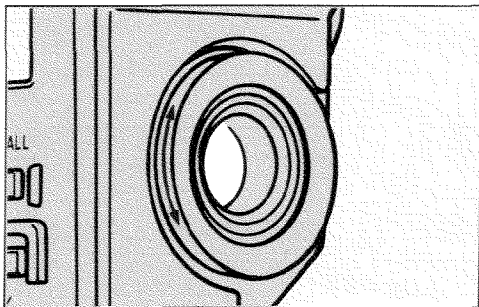

The Spotmeter F has a fixed-focus objective lens that provides correct focus from 1.3 meters to infinity.

To compensate for individual eyesight variations, the meter's eyepiece is adjustable through a range of -2.5 to $+1.2$ diopters. To make this adjustment, look through the eyepiece and turn the eyepiece guard to the right or left until the 1° spot circle appears in sharp focus.

NOTE

- Light entering the eyepiece may cause incorrect readings. When taking a reading without looking through the eyepiece, cover it with your hand or other opaque object.

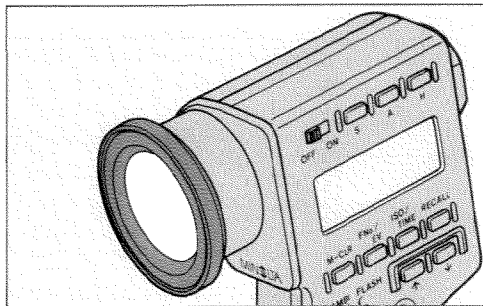

Optional close-up lens

An optional close-up lens is available for the Spotmeter F. This lens attaches to the front of the meter and permits measurements of subjects from 0.6 to 1.4 meters.

DISPLAYS

External display

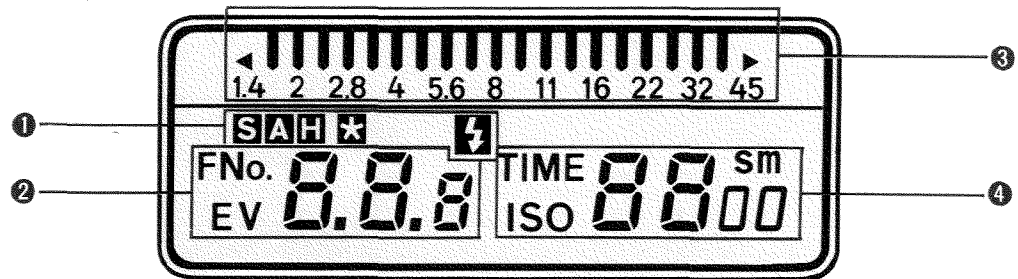

① Calculation modes:

S – shadow

A – average

H – highlight

X mark appears with S, A, and H calculation-mode indicators. Indicates that the calculated reading will be used as the standard for monitoring the brightness of other areas of the scene.

⚡ Flash mode indicator

② FNo./EV display mode indications

③ Analog scale:

▮ – Analog-scale pointers

◀ ▶ – Under/over-range indicators

1.4 to 45 – F-number scale

④ Film/shutter speed indications

“s” – seconds

“m” – minutes

Analog display

The Spotmeter F has an analog aperture scale along the top of the external display. When a measurement is made in either f-number or exposure-value display mode, a pointer will appear above the aperture figure corresponding to that shown on the digital display in f-number display mode.

The analog scale is marked in half-stop increments, so the pointer may appear between two aperture figures depending on the digital display's decimal figure. For example, if the digital display is from $f/8.0_8$ to $f/11_2$, the analog pointer will appear directly above $f/11$. If the digital display is from $f/11_3$ to $f/11_7$, the pointer will be between $f/11$ and $f/16$. If the digital display is from $f/8.0_3$ to $f/8.0_7$, the pointer will be between $f/8$ and $f/11$.

When using the memory function (p. 28) to monitor the lighting in several areas of the scene, up to four pointers will appear on the analog display.

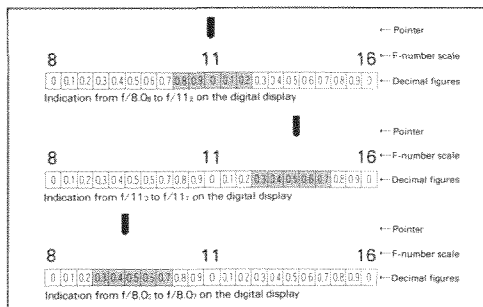

Viewfinder display

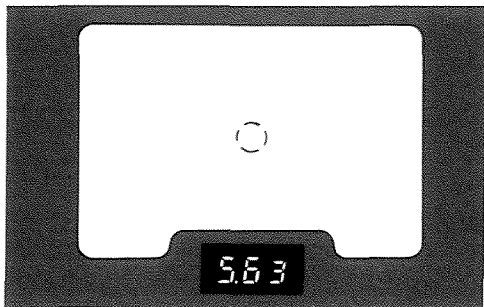

In addition to the meter's external display, there is also a digital display in the viewfinder that lets you to monitor the exposure information while taking a reading. The f-number, EV number, and brightness differences are displayed with tenth-stop accuracy. The measuring spot defines the meter's 1° angle of acceptance.

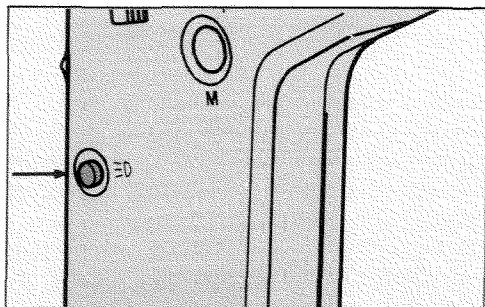

The viewfinder display can be illuminated for easier reading in low light by pressing the display illumination button located on the meter's grip.

Over-range and under-range warnings

In f-number mode, the meter's digital f-number display range is from f/0.7 to f/90_g. When the letter "E" and a triangular pointer on the analog scale appear, the reading is outside of this range. If this occurs in ambient-light mode, you can change the shutter-speed setting to obtain a readout without having to take another measurement. In flash mode, you will need to take a new reading.

When the reading is over or under the meter's measurement range, the letter "E" appears without a triangular pointer. In this case, take another reading of a different area.

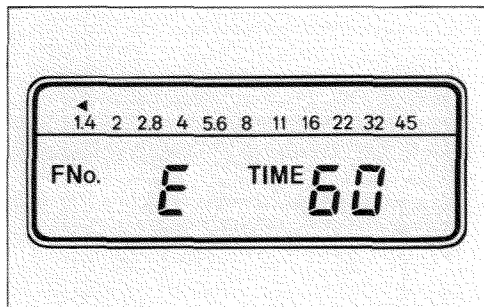

SETTING THE FILM SPEED

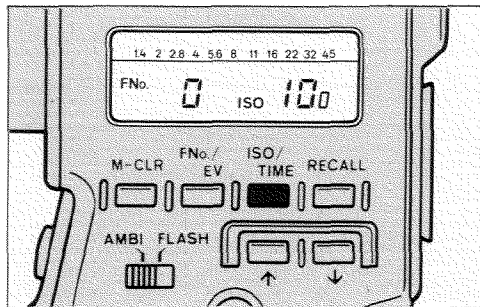

1. Press the ISO/TIME key to display the ISO film-speed setting. If the battery has just been installed, "100" (ISO 100) will be displayed.

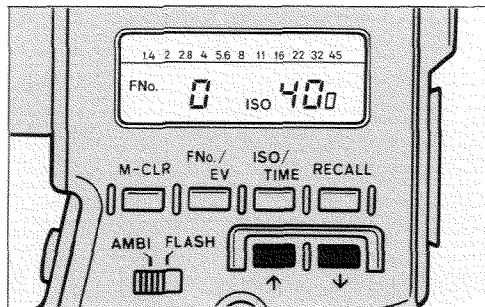

2. Press the increase key to set higher film speeds; press the decrease key to set lower film speeds. The setting changes by 1/3 stop each time either key is pressed and continuously when a key is held down. Any film speed from ISO 12 to ISO 6400 can be set.

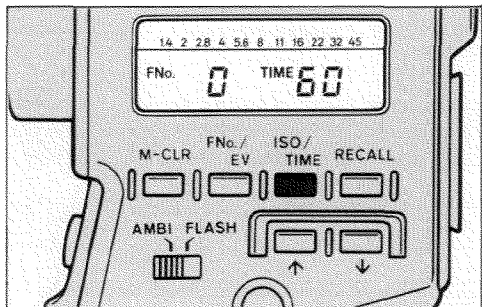

3. After setting the film speed, press the ISO/TIME key to return to the time-display mode.

NOTE

- The third and fourth digits of the ISO display can only show zeros. Thus, "120 " and "1200" are displayed for the ISO 125 and ISO 1250 settings, respectively. The meter is correctly calibrated for the actual settings.
- IN THE ISO-DISPLAY MODE, MEASUREMENTS CANNOT BE TAKEN; only the increase, decrease, and ISO/TIME keys will operate.
- The meter can only be set for ISO film speeds. To find the equivalent ISO rating for DIN-rated films, consult the conversion table located on the back of the battery-chamber cover.

SETTING THE SHUTTER SPEED

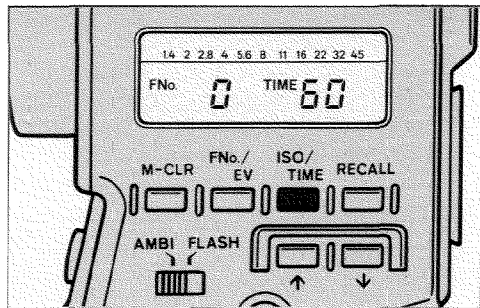

After setting the film speed, press the ISO/TIME key to put the meter in time-display mode. The display will show the most recently set shutter speed. If the battery has just been installed, "60" (1/60 sec.) will be displayed.

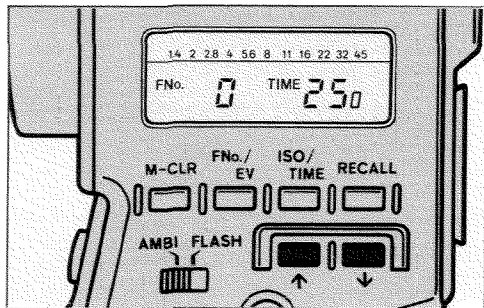

To change the shutter speed, press the increase or decrease key until the desired speed is displayed. Each time either key is pressed, the display will change by one full stop. The speed changes continuously when either key is held down.

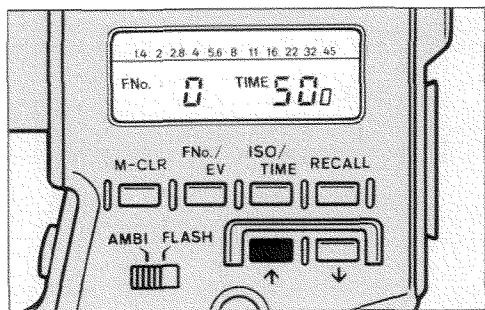

In ambient metering mode, the shutter speed can be set from 1/8000 sec. to 30 minutes, plus 1/50 sec. (which comes after the 30 min. when pressing the decrease key) for taking cine readings at 24 fps.

If the displayed shutter-speed figure is followed by a small letter "s", this denotes a speed in full seconds; a small "m" denoted speeds in minutes. If there is no letter designation, the shutter speed is the reciprocal in seconds of the number displayed (e.g., "30" represents 1/30 sec.).

In flash metering mode, the shutter speed can be set from 1/1000 to 1 second. When switching from ambient to flash mode, if the shutter is set to speeds shorter than 1/1000 or longer than 1 sec., the speed will be reset as follows:

AMBIENT MODE	→	FLASH MODE
1/2000 to 1/8000 sec.	→	1/1000 sec.
30 min. to 2 sec.	→	1 sec.
1/50 sec.	→	1/60 sec.

NOTE

- The third and fourth digit of the shutter-speed display can show only zeros. Thus, "120" is displayed for the 1/125 sec. setting. The meter is correctly calibrated for the actual setting.

SELECTING FNo./EV DISPLAY MODE

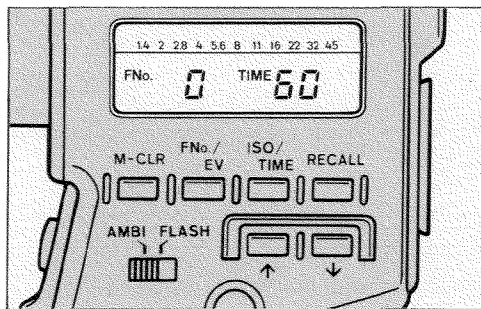

The Spotmeter F has two display/measurement modes, f-number (FNo.) and exposure value (EV). Press the FNo./EV key to display the desired mode on the external LCD display panel.

You can alternate between these two modes when "TIME" is displayed and "AMBI" mode is selected. When "FLASH" mode is set the f-number mode will be selected automatically.

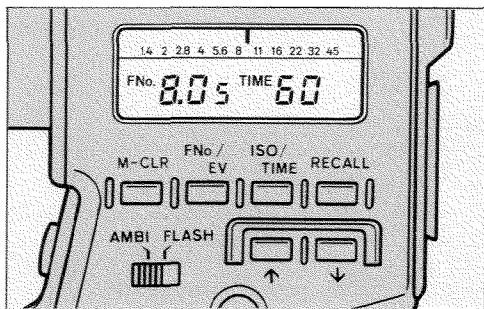

In f-number mode, a digital aperture figure will appear next to the "FNo." indication in the display panel. Next to this figure is a small one-place decimal display that shows the necessary exposure decrease in 1/10 stops. For example, if the aperture display is f/8.0₀, the lens should be set at exactly f/8. If the display shows f/8.0₅, then the exposure should be decreased by 5/10 (1/2) stop. The lens aperture should be set halfway between f/8 and f/11.

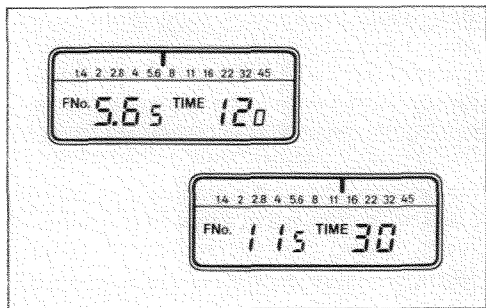

When taking ambient-light readings, changing the ISO or shutter-speed setting will change the f-number displayed.

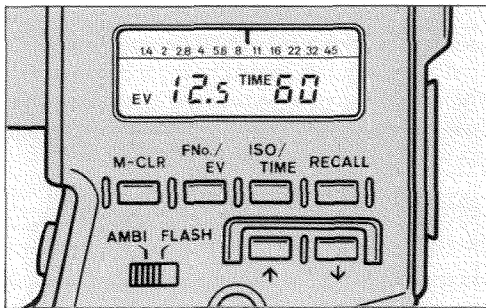

The EV display mode is useful for checking contrast ratios (p. 39), luminance (p. 40), and other lighting conditions. In this mode, the display readout will be in EV steps, and only changes in the ISO setting will affect the EV display.

F - 0.7 to 90 + 0.9 stop
 EV - -4.3 to +28.5 in 0.1 stop
 BD - -9.9 to +9.9 stops in 0.1 stop

GENERAL INFORMATION

To realize the full potential of your Spotmeter F, some basic information about it and spotmeters in general should be understood.

A spotmeter is basically a reflected-light meter, much like the built-in meter of a camera. The advantage of a spotmeter is its ability to measure an extremely small and precise area of a scene without reflected light from other areas influencing the reading. This permits metering of the most important areas of a scene.

Like all reflected-light meters, the Spotmeter F is calibrated to give a reading that falls on the mid-point of the film's characteristic curve, and will be reproduced as a mid-tone (medium) density on the film. In other words, the meter gives a reading that will result in "normal" exposure for an "average" subject. An average subject is generally defined as one that reflects about 18% of the light that strikes it.



Mid-tone readings

The simplest and quickest measuring method for using the Spotmeter F is to take a reading of a mid-tone area in the most important part of the scene and ignore darker and lighter areas. Using this method, you are most concerned with a single area and only one reading is needed. Best results will be obtained when the point being measured corresponds very closely to a mid-tone value.

Ambient Light Measurements

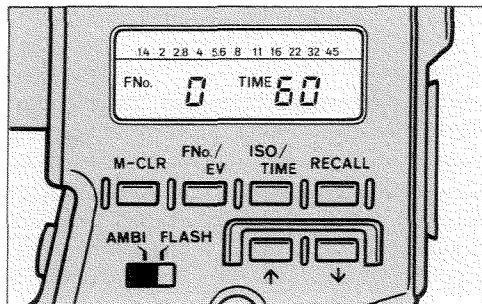

1. Set the metering mode switch to "AMBI" and the display mode to f-number mode.
2. With the meter in "TIME" mode, set the shutter speed by pressing the increase and decrease keys. Any speed from 1/8000 sec. to 30 min, can be set in full stops. For cine measurements (p. 42), 1/50 sec. can be set.

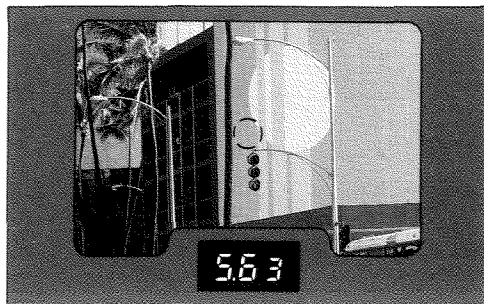

3. Look through the eyepiece and position the 1° spot circle on the area you wish to measure.
4. Press and hold the measuring button until a reading appears in the viewfinder's display. The meter will continue to take readings as long as the measuring button is held in. Release the button when you want to hold a reading.

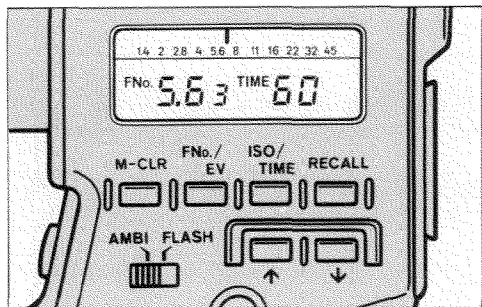

5. Set your camera to the shutter speed and aperture shown on the meter's digital display.

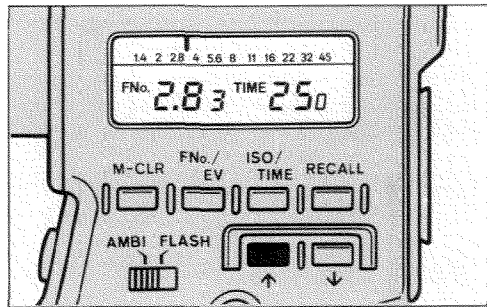

If desired, other aperture/shutter speed combinations can be displayed by pressing the increase or decrease keys.

NOTE

- Readings cannot be taken when "ISO" is displayed.

CAUTION

Never point the meter directly at the sun. Doing so could damage your eye, as well as damage the meter's measuring cell.

Flash Measurements

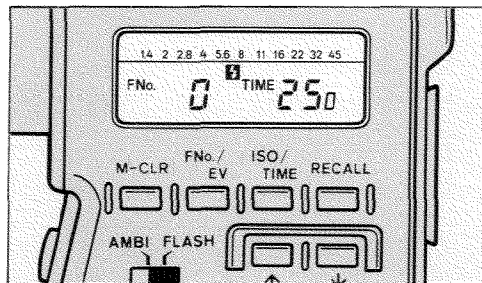

1. Set the metering-mode switch to "FLASH". F-number display mode will be set automatically.
2. With the meter in "TIME" mode, set the shutter speed by pressing the increase and decrease keys. For flash measurements, any speed from 1/1000 to 1 sec. can be set in full stops. Make sure the shutter speed you set is within the camera's X-sync range.

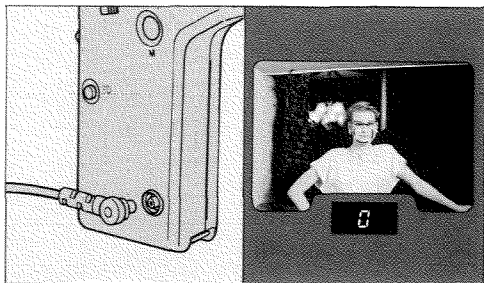

3. Plug the flash's sync cord into the sync terminal on the meter.
4. Look through the eyepiece and position the 1° spot circle on the area you want to measure.

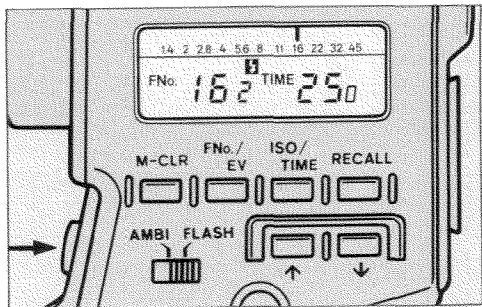

5. Press the measuring button to fire the flash and take a reading.
6. Set your camera to the aperture and shutter speed shown on the meter's digital display.

NOTE

- Readings cannot be taken when "ISO" is displayed.
- After taking a reading, if you change the shutter speed setting, the f-number display will show "0" and a new reading must be taken.
- Some flash units may fire when the sync cord is attached.
- Before making the actual exposure, connect the sync cord to the camera and check that the camera is set to the proper X-sync speed.
- For added convenience, use of the optional Sync Cord II is recommended.
- If the Spotmeter F does not function with your flash unit, contact your near authorized Minolta service center.

EXPOSURE CALCULATION MODES



For many scenes, a single mid-tone reading will provide proper exposure; however, over- or under-exposure will result if a very dark or very light area is measured. Since the meter cannot make a subjective evaluation of the lighting, it indicates a reading that will produce a mid-tone density on the film. To obtain a correct exposure for dark or light areas, compensation must be made to shift the exposure to the shadow or highlight portion of the reproduction curve.

The Spotmeter F can calculate and display the necessary highlight and shadow compensation. By using the memory function, the meter can calculate an average of two readings. At the push of a key, calculation is done automatically and displayed with tenth-stop accuracy.

The Spotmeter F calculates highlight and shadow exposures based on the 5-stop latitude of color slide film. Slide film was chosen because its narrow latitude demands the most critical exposure, and because of its wide use among professional photographers. While the meter's shadow and highlight calculations are based on slide film's characteristics, excellent results will be obtained with negative films, since they have wider latitude and flexibility in development and printing processes. Mid-tone readings and averaging calculations are the same for all films.

Besides calculating the correct exposure, the meter can also display up to four readings, so that you can previsualize exposure results. You can pre-check which areas will be washed out, show shadow detail, and be reproduced as mid-tone densities.

The following sections explain how to use the meter to calculate exposures for highlight and shadow areas, as well as making an averaged exposure based on two readings.

Using the memory function

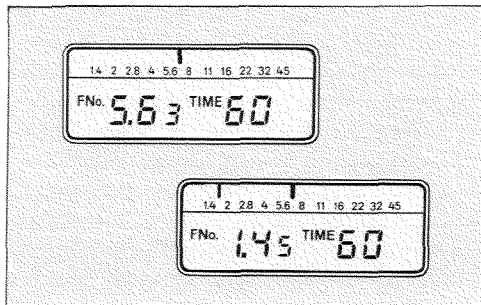

To use the Spotmeter F's memory function, take a reading and press the memory key. The display will go blank for a moment and then reappear after the reading is entered into the memory. You can now take a second reading which will be indicated by a pointer on the analog scale and by a new

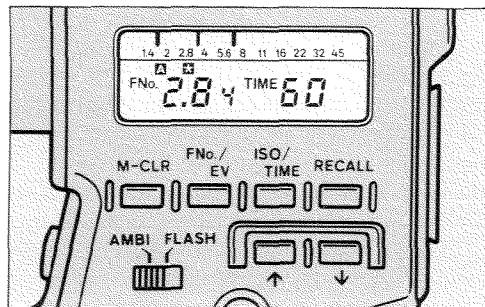

digital readout. This second reading can be entered by pressing the memory key again.

If two readings have been memorized and the averaging, shadow, or highlight key is pressed, the calculated reading will be displayed digitally and a third pointer will appear

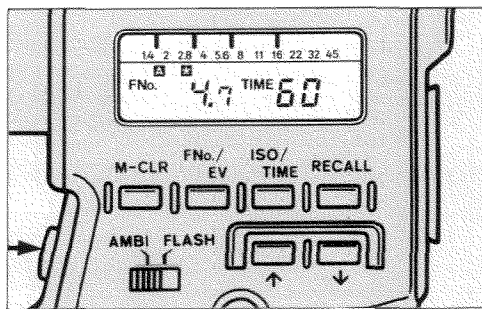

on the analog scale next to indicated the f-number. A \square mark will also appear indicating that any further readings will be displayed as differences in brightness from the calculated reading. These readings will also be indicated by a fourth pointer on the analog scale. Refer to page 36 ~ 38 for more information.

NOTE

- Only two readings can be memorized at any time. "E" will appear if you attempt to memorize a third reading. If this happens, press the memory-recall key to clear the error display.
- To clear all memorized readings, press the memory-clear key.
- When two readings are memorized, one of the readings will be displayed by pressing the memory-recall key and release it, the most recent reading will appear again. By holding down the key again, the other reading will be displayed. if no readings are memorized, "0" will appear in the FNo./EV display when the recall key is pressed.
- Memorized readings are retained even when the meter is switched off.
- It is not possible to memorize a reading that is calculated by using the averaging, highlight, or shadow keys.

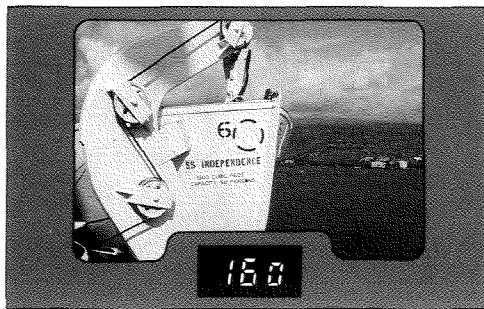

Highlight readings



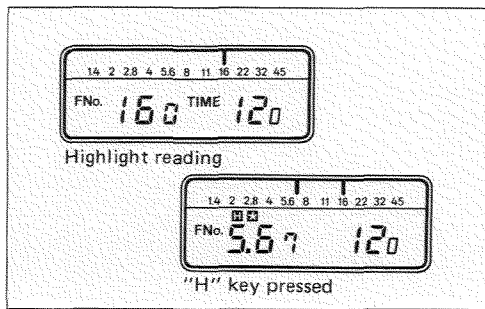

If it is most important to correctly record the bright highlight areas of a scene, then priority must be given to them and the shadow areas allowed to black out.

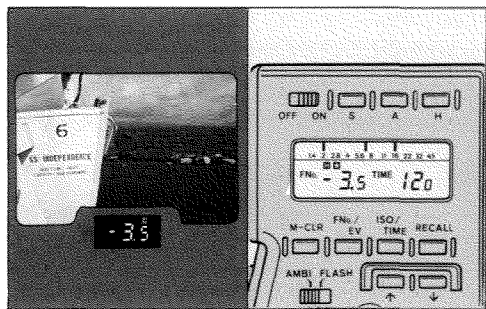

To make a highlight reading, first press the memory-clear key to clear any previously memorized readings, then proceed as follows:

Take a reading of a bright highlight area, then press the highlight key. When the highlight key is pressed,  and  will appear on the digital display. These indicate that the correct exposure for the highlight area has been calculated and displayed digitally. Analog pointers will indicate the original reading and the calculated exposure.



If another reading is made when the  mark is displayed, the meter will indicate the difference in brightness between the calculated reading and the new reading. Refer to page 36 ~ 38 for more information.

NOTE

- It is not necessary to memorize a highlight reading. However, if you have used the memory function to memorize two readings, the highlight calculation will be based on the higher of the two. If memorize one reading only, the calculation will be based on the memorized reading.
- The calculated highlight-exposure point gives an additional 2.3 stops of exposure to the measured area so that it will record as a highlight.
- Before taking a new reading, first press the memory-recall key to clear the highlight calculation from the display. Then, the most recent reading will appear again.