

STANDARD TAPE MANUAL

A data book
for the AUDIO tape recordist,
engineer or designer

COMPILED BY ROBERT K. MORRISON
FOUNDER
STANDARD TAPE LABORATORY

STANDARD TAPE MANUAL

A data book
for the AUDIO tape recordist,
engineer or designer

COMPILED BY ROBERT K. MORRISON
FOUNDER
STANDARD TAPE LABORATORY

Published by R. K. Morrison Illustrative Materials,
819 Coventry Road, Kensington, California 94707.

We have attempted to correct any errors in the data found in this book, however the use of the material herein will be at the sole risk of the user.

The compiler wishes to thank the following for their helpful assistance in collecting and arranging the material for this manual:

Mark Drake

King Harrington Jr.

Frank R. Killinger

Frank G. Lennert

John Leslie

Don Lincoln

Clyde McKinney

Patricia Morrison

Walter F. Storer

W. D. (Bud) Taber

E. E. Richter Jr.

TABLE OF CONTENTS

SECTION 1 – HEAD LOSSES

Gap losses, Core losses, Spacing losses.

SECTION 2 – FLUX LEVELS

Normal, Elevated, and relative difference chart.

SECTION 3 – AZIMUTH:

Determination, results of misalignment on phase error in various track configurations, level losses due to azimuth disagreement, five charts.

SECTION 4 – REPRODUCE AMPLIFIER RESPONSE:

Definition of induction loop response, and amplifier characteristics.

SECTION 5 – AMPLIFIER CURVES, INDUCTION LOOP RESPONSE CURVES, IDEAL RESPONSE CHARTS.

SECTION 6 – WAVELENGTH CHARTS: English and metric.

SECTION 7 – PRACTICAL TECHNIQUES OF MEASUREMENT:

(A) HOW TO MAKE INDUCTION LOOP MEASUREMENTS

(B) HOW TO MEASURE CONSTANT CURRENT THROUGH THE RECORD HEAD:

Low end calibration

(C) HOW TO MEASURE TRACK WIDTHS:

Charts for formats 150 mil through 2"

(D) LOSSES TO RECORDED SIGNALS:

Storage, bending loss, oxide abrasion, demagnetization.

(E) HOW TO MEASURE DISTORTION:

Importance of separating second and third harmonic content from total readings.

(F) HOW TO CHECK FOR MAGNETIZED COMPONENTS AND OTHER ELECTRICAL FIELDS CAUSING UNWANTED ERASURE AND NOISE:

Measurement equipment illustrated: simple magnetometers, Hall effect magnetometer, indicator fluids, and magnetic viewers.

(G) HOW TO CHECK FOR HEAD RESONANCE:

Including, cable and core loss effects.

(H) HOW TO CHECK FOR STATIC NOISE CAUSED BY UNGROUNDED HEADS, AND HOW TO REMEDY.

(I) WEAR PATTERNS:

Illustrations of wear patterns to heads, guides, and idlers, and how to initially insure that your equipment will not suffer from instability caused by uneven wear to these components.

INTRODUCTION

This data book will, we hope, be useful to those who must have the basic information necessary to standardize, maintain, or design audio magnetic tape reproducing systems. It is a book for those who are familiar with the fundamentals of magnetic recording and simply require a quick source of reference data to "plug in" to their routine endeavors.

The intent in compiling this lab manual was to provide that material not readily available in the many texts treating magnetic recording.

In the process of helping users of magnetic recording equipment to select appropriate test tapes and to interpret correctly the results obtained with these tapes, it has become evident what sorts of information are required by users of such equipment.

Consider the possible need to design a suitable reproducer for four track $\frac{1}{4}$ " tapes having CCIR equalization and response to 20 kHz at 7.5 ips (19.05 cm/s). One could proceed as follows:

- (1) Select appropriate response chart from Section #5.
- (2) Note proper track dimensions for head selection in Section #7.
- (3) Determine shortest wavelength to be encountered (See chart, Section #6)
- (4) Consult Section #1 to obtain a practical gap specification for a suitable reproduce head for the response desired.

In the above four steps, requiring only a few minutes, one can determine the basic practical specifications needed to proceed with the job at hand. Other considerations such as the needed amplifier headroom will depend on the operating levels encountered. Section #2 will aid in this area, as will Section #3 in determining the minimum achievable phase error between tracks, as related to Azimuth error.

SECTION 1

Head Losses

CONSIDERATIONS CONCERNING THE REPRODUCE HEAD GAP:

The most significant losses due to gap effects occur in the reproduce head. As the wavelength of the signal to be reproduced approaches the effective length of the head gap, the flux induced in the head drops rapidly, nulling out when the gap is a multiple of the recorded wavelength.

At audio frequencies and normal tape speeds, the record head accounts for very little wavelength loss. The attached nomograph indicates losses caused by the playback head at various wavelengths. Since wavelength is determined by dividing the tape speed by the frequency involved, we can appreciate that very short wavelengths are encountered at high frequencies and slow tape speeds. (For example 10kHz at 1-7/8 ips is only 0.187 mils in length and therefore a short gap reproduce head is called for to reproduce material at this speed.) The term "gap length" of a magnetic head is often confused with the track dimension. Length refers to the distance between pole pieces established by the spacer. The thickness of the spacer determines the physical dimension of the gap length; however we must bear in mind that the physical gap length is not precisely the effective or magnetic gap length. Gap lengths are controlled during the manufacture of magnetic heads by selecting the desired spacer, or shim, and by measurement of the material by mechanical and optical means. Often the OPTICAL gap is less than the thickness of the original shim material, due to the result of compression during assembly. This is particularly true when the gap is made of paper or other soft material. The MAGNETIC GAP length is ALWAYS greater than the physical gap length. The difference can range from only a few percent to 15%. If one wishes to estimate the magnetic gap, a good conservative practice would be to use a factor of about 1.15. Therefore, if the playback head has a 100 micro-inch spacer, a maximum effective gap of 115 micro-inches may be used to obtain an approximate gap loss to be expected from this head at a specific wavelength. An accurate measurement of the actual or magnetic (i.e. effective) gap length can be accomplished through experimental means. A slowly rising sweep frequency is recorded, and the playback observed simultaneously. The null points of the

reproduce head will be obvious and will appear at somewhat longer wavelengths than the thickness of the spacer material, as noted above.

CONSIDERATIONS CONCERNING THE RECORD HEAD GAP:

The efficiency of the record head at all wavelengths, depends upon its gap length. In audio work we tend to keep the gap length rather long for recording use, for example $\frac{1}{2}$ to 1 mil. Where a combination record-reproduce head must be used, a compromise must be made to select a head with a gap long enough to be efficient for recording and yet not too long to be able to reproduce the necessary short wavelength information. Also where wide range Sel-Sync* response is required at moderate tape speeds, the gap length of the record head must be compromised. The shape of the bias field produced by a short gap record head causes such recording to be more susceptible to dropouts and a very short gap head is difficult to drive, so good practice is to avoid record gaps much shorter than $\frac{1}{2}$ mil, unless other considerations specifically necessitate such a choice. (A specific exception to this very low speed recording such as in cassette and logging formats, where thin oxide tapes and quite short gap record heads ARE in order.)

In instrumentation work, the very short wavelength requirements often dictate the use of very short gap record and playback heads. As a matter of interest we have provided a chart showing the variation in an instrumentation system having fixed reproduce heads with various record heads having gap spacers ranging from 50 micro-inch to 200 micro-inch. Note that the six db spread occurs at very high frequency at the indicated speed which is 120 ips. Cassette and logging speeds have similar requirements as to wavelength so the chart can be used to directly apply to such systems. *Trademark of Ampex Corporation

PRACTICAL USE OF THE GAP LOSS NOMOGRAPH:

Before giving a practical example of the use of the nomograph, we should mention that there are other losses associated with the reproducer head, namely core losses and spacing losses. In audio these tend to be less of concern than the gap losses encountered in an average system. To determine the loss expected from the gap loss alone, one can use the nomograph thusly: For a given frequency, say 15kHz on a $7\frac{1}{2}$ ips tape, the wavelength is determined from the wavelength chart or simply by dividing the tape speed by the frequency. In this case, the wavelength is 0.5 mils.

A straight edge is positioned to line up the gap length of the head (let us say for this example it is 130 micro-inches), with the wavelength of 0.5 mils. In this example, the loss from such a head at this frequency and tape speed would be expected to be 1.0 db.

In designing a theoretically perfect reproduce channel for use with a head gap of 130 micro-inches, at a tape speed of $7\frac{1}{2}$ ips with the upper limit of 15kHz, one would then equalize the reproduce channel to deviate from the appropriate curve selected from section #5, by one db at 15kHz, to compensate for gap loss.

CORE LOSSES

Core losses are a function of frequency, not wavelength as is the case with gap and spacing losses, and thus will affect a given head at the same point in the audio spectrum regardless of tape speed.

Core losses can result from excessively thick head laminations, or lack of proper insulation between laminations in the stack or between stack and frame. The core IS grounded to the frame to eliminate static buildup and discharge (see section #7), but at only one point. The overall efficiency of the core also depends

GAP LOSS NOMOGRAPH

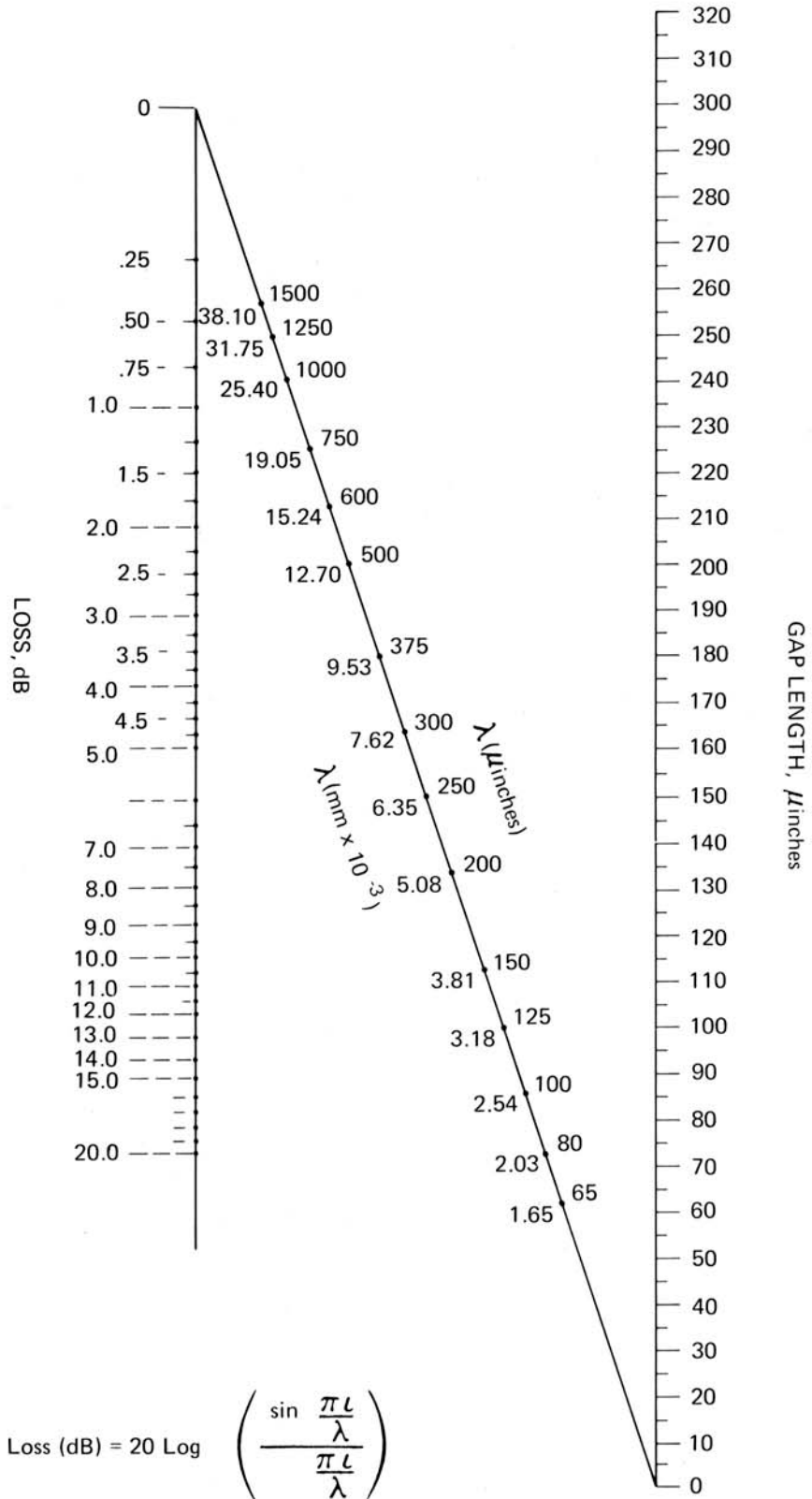

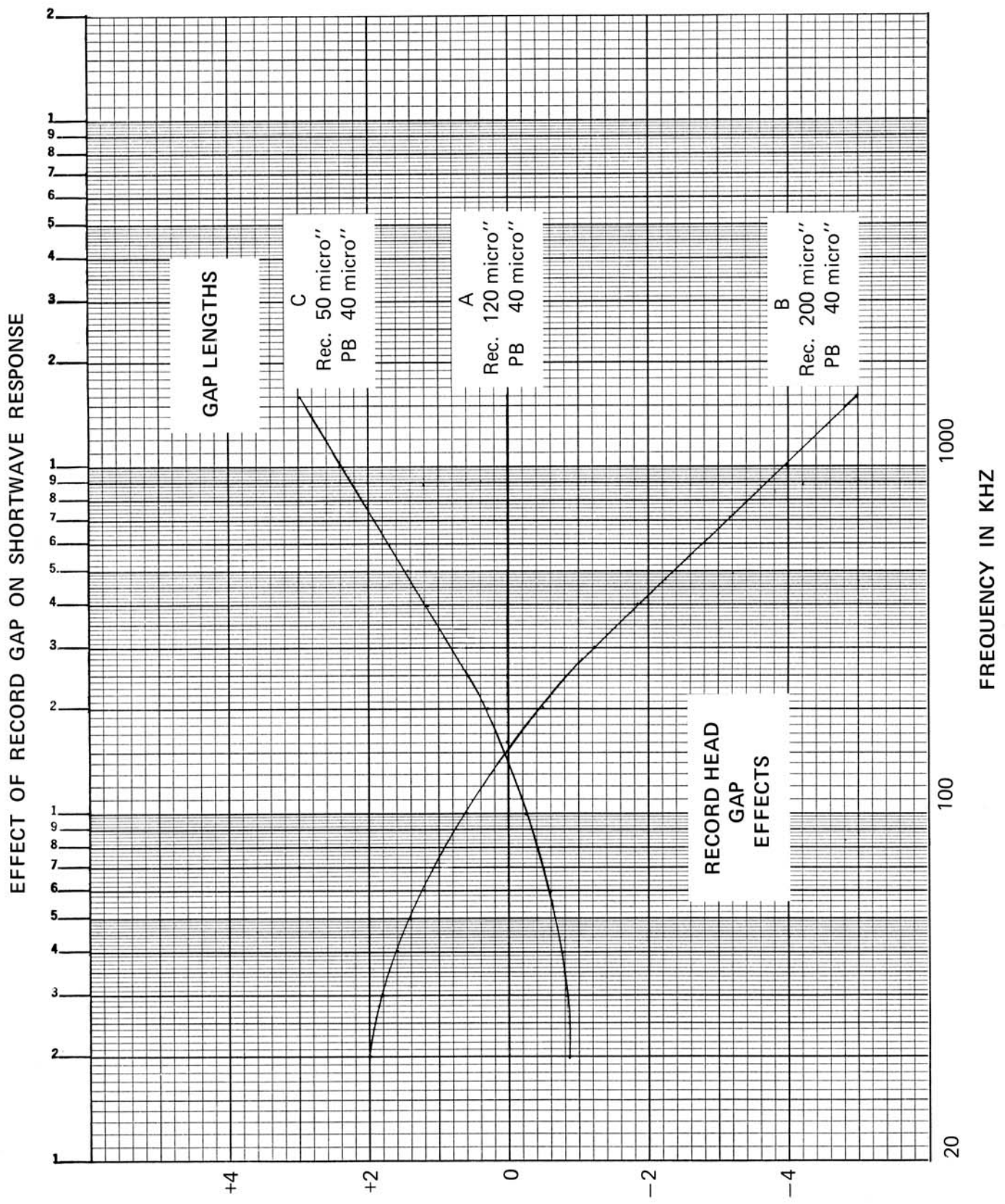

upon the permeability of the core material after annealing.

Core losses found in modern magnetic heads used for audio usually are minimal over the normal audio spectrum; however, such losses can be significant in the case of duplicators or instrumentation systems where frequencies outside the normal audio band are encountered. To be specific, a typical audio head may show a small high frequency loss due to core effect at 20kHz while the same head could be deficient by several db at 120kHz if it were used in a medium speed duplication system. Core losses will show up during loop induction measurements of playback systems as described in section #7 dealing with practical measurements.

SPACING LOSS – formula: loss in db = $54.6(d/\text{wavelength})$ where d = spacing distance

Any separation between oxide and tape head pole pieces results in spacing loss. The shorter the wavelength, the greater the loss for any given separation. The “55db” loss formula actually indicates a loss of 54.6 db for every one wavelength of separation. One can see, therefore, that a system suffering from a spacing problem of 100 micro-inches would cause a recorded signal of 7.5kHz recorded at 3.75 ips (wavelength of 0.5 mil) to lose in reproduction, 1/5th of 54.6 or 10.92 db!

An important caution to be observed in accounting for spacing loss is the fact that spacing losses due to oxide buildup on heads do not usually extend over the whole track area, and depending on head geometry and tape tension, the reproduce head will average the signal from the uncontaminated portion of the tape or head.

Thus a full track recording may reproduce reasonably satisfactorily despite a severe loss in one area across the wide reproduce head. Spacing losses are usually a more frequent problem in the case of narrow tracks as used in multiple track formats.

SECTION 2

Flux Levels

The importance of standardization of operating and reference levels is well understood. Calibration of equipment, for interchange of tapes and adjustment of noise reduction apparatus, requires accurate control of flux levels.

The expression FLUX LEVEL and the term Fluxivity represent the strength of the signal once it is recorded on magnetic tape. It is presently practical to express the degree of magnetization in absolute terms at medium wavelengths. The current practice is to state the signal strengths in billionths of a Weber per meter. Thus the most commonly encountered operating level today for 7½ ips reel to reel recording may be expressed as 185 nWb/m, at a given wavelength. (Often 700Hz or 10.7 mil wavelength at that speed).

EUROPEAN PRACTICE IS TO OFTEN STATE FLUX LEVELS IN MILLI-MAXWELLS PER MILLIMETER.

Thus 100 nWb/m could be expressed as 10 millimaxwells per millimeter. To say it another way, when encountering a cassette standard for example indicating a peak level reference of 25 mMx/mm, we have only to add a zero to express the level in nanoWebers. (250nWb/m)

A brief mention should be made of the origin of choices for operating levels to be employed with the available tape and equipment. Before standards organizations addressed the subject, the industry, largely one company—determined experimentally that level which caused 3M 111 A tape to generate one per cent third harmonic distortion of a 15 mil wavelength signal when bias was adjusted for a maximum output of that signal. The 185 nWb/m flux level reference thus became “standard operating level” in U.S. practice, and is the standard from which most other recommendations have evolved. A word of warning: In the 50’s and 60’s several theoretically oriented writers took an interest in pinning down the absolute value of the empirically derived standard operating level and some published findings after measurement by very crude means. Anyone familiar with the literature of the time may remember figures ranging from 175 to 210 nWb/m, describing the *same* flux reference tape.

Fortunately the test tapes of the time were made using comparison tests to vault copies maintained for that purpose. Therefore, while our methods of "absolute" measurement were poor, the practical level references were held to very respectable tolerances. The professional test tapes of the time stayed within plus or minus $\frac{1}{4}$ db at medium wavelength reference set. The early attempts at absolute measurements with vibrating magnetometers, have largely been supplanted by measurement employing specially constructed flux measuring heads designed for measurement at medium wavelengths.*¹ The use of such a head requires a calibrated voltmeter, a frequency counter and means of determining exact width of the recorded track. The accuracy of such a system has been quoted as ranging from 3% to 5% depending upon the individual tolerances of the measurement components. In practice, this author has seen a spread of about 10% in measurements taken by professionals using the SAME reference tape, and even on occasion the same flux measurement head. The extra 5%, in my opinion, was due mostly to *mechanical* problems such as slight spacing losses and variance in technique of measurement of track widths encountered in different laboratories.

The above method, using the special flux measurement head, provides a voltage reading from the tape being measured, which is then applied in the formula along with the exact track width and wavelength. In making any of the measurements, we must remember that the recorded track may not be uniform across its width. The total flux will be averaged, and therefore, it is desirable to confirm that the tape is uniform across the track or tracks being measured. This can be checked in several ways: turning over the tape on multiple track equipment or scanning the tape with a narrow, vertically adjustable head are two methods. We should point out here, that the heads used to make test tapes are usually controlled to produce tapes having very little flux variation across the track. Record heads used in normal professional service often produce enough flux variation to indicate a spread of 1 or 2 db over a track width of 247 mils when scanned with a single 43 mil track, mounted on a "dove tail" assembly providing displacement of the head. Many ferrite record stacks with uneven core density show considerably more variation. It is for this reason that, up to now, the most successful special heads for wide format test tape use have been of stacked lamination construction with very carefully controlled evenness of gap depth to insure the most constant flux to the tape across its width.

Many cases of confusion have resulted from attempts to set up duplicators using peak reference test cassettes, on VU metered equipment, resulting in saturated tapes. What a VU meter detects and indicates is the general energy content of a program from moment to moment. The ballistic response of a true VU meter was carefully chosen and specified for ease of reading and accuracy of application to a wide range of normal speech and music material; the general understanding has been that at least 10 to 15 db of "headroom" in the recording or transmission medium is required between the zero VU level and the overload point, to accommodate the instantaneous peaks characteristic of speech and music. Thus, a reference level tone, for use with a recorder utilizing a VU meter would be chosen so that it would produce a flux level on the tape 10 to 15 db below tape saturation. If this tone were played back on a properly calibrated recorder equipped with a peak indicating meter, the meter would rise only to the level of the peak of the sine wave—far below the maximum permissible program peak level which produces reference deflection of a peak-indicating meter. If the meter calibration of such a machine were mistakenly sensitized to give a reading

*1. The Measurement of Medium-Wavelength Flux on A Magnetic Tape Record. J. G. McKnight, 36th Convention AES April 28, 1969 Preprint 654 (H-3)

of full modulation on the VU related reference tone, subsequent program recordings would be seriously under-recorded.

Correspondingly, the sine wave reference tone placed on a test tape intended for peak indicating meters is chosen so that its peak value is near the maximum capacity of the medium to handle, and if a VU metered machine were misadjusted to cause this tone to indicate Zero VU, subsequent recordings would be badly distorted.

From this it will be recognized that not all of the various reference flux levels encountered represent different choices of program operating level; each actual operating condition requires two different sine wave reference tones, to calibrate two different level indicating systems.

Note: It has been suggested that calibration tapes be recorded with a non sine wave reference tone of such character that its peak value bears such a relation to its RMS value that it could be used to calibrate either system. Though possible, this presently seems to have more drawbacks than advantages.

With the advent of newer tape oxides, it has become desirable to record at higher levels to increase signal to noise ratio. Some years ago, the (206 and 406) higher output tapes permitted a practical increase in level of 3 to 4 db over the older oxides, and therefore, an ELEVATED LEVEL became popular for mastering. The term ELEVATED LEVEL and the figure of plus 3 db were pretty much the writer's doing. (Remember that we are talking about VU meter readings as common in the U.S.A.) Round numbers are convenient, and 3 db above the established 185 nWb/m (261 nWb/m) was and remains a good increment. It would seem that this flux level has become the most popular for use in master recording in the U.S.A. It should be understood that these excellent high output tapes are best suited for use at the mastering speeds of 15 and 30 ips. At very slow speeds these mastering tapes are less suitable than thin oxide tapes intended to favor the short wavelengths encountered, for example, in logging machines running at 1-7/8 ips or slower.

The more recent mastering tapes (250, 456, etc.) provide another 3 db or better over the previously available tapes and therefore ELEVATED LEVEL EL6 (i.e. a level six db above the 185 nWb/m) has become used to some extent. EL6 represents 369 nWb/m. Much of the existing electronics in the field may limit the practical use of EL6 even though the tape itself is capable of satisfactory results. Some of the latest equipment is designed to operate at this level when using the appropriate tape. In practice, many of the studios have elected to stay with EL3 and, in so doing, retain the same approximate signal to noise ratio and at the same time enjoy the added "headroom" possible with the new tapes.

Some rather spectacular new oxides are in the offing and any equipment manufacturers would do well to consult the leading manufacturers of tape before proceeding with the design of any new tape equipment. Otherwise, the system may suffer in that it will be electronics limited rather than medium limited.

The following chart may be used to indicate various flux levels as they compare to a zero reference of 185 nWb/m. Formulae are also provided to allow slide rule and calculator computations for any flux level comparisons.

RELATIVE FLUX LEVELS

(Compared to the 185nWb/m Commonly Used Operating Level)

DB	Flux level in nWb/m
0	185
.5	196
1	208
1.5	220
2	233
2.5	247
3	261
3.5	277
4	293
4.5	311
5	329
5.5	348
6	369
6.5	390
7	414
7.5	439
8	465
8.5	492
9	521
9.5	552
10	585
10.5	620
11	656
11.5	695
12	736
12.5	780
13	826
13.5	875
14	927
14.5	982
15	1040

**FLUX LEVELS FREQUENTLY CALLED OUT
IN U.S. AND EUROPEAN STANDARDS:**

referenced to 185nWb/m

100 nWb/m = -5.4 db

140 nWb/m = -2.5 db

160 nWb/m = -1.3 db

200 nWb/m = + .7 db

250 nWb/m = +2.6 db

320 nWb/m = +4.8 db

360 nWb/m = +5.8 db

$$\begin{aligned} \text{Flux Level} &= 10 \left[\frac{\text{dB}}{20} + \log_{10} 185 \right] \\ &= 10 \left[\frac{\text{dB}}{20} + 2.267 \right] \end{aligned}$$

or may be written

$$\text{Flux Level} = \text{Antilog}_{10} \left[\frac{\text{dB}}{20} + \log_{10} 185 \right]$$

SECTION 3

Azimuth

Direct magnetic recording produces "bars" made up of magnetized oxide particles. These lines or bars when produced by means of a record head gap of perfect straightness aligned to be exactly 90 degrees with reference to the edge of the tape, would constitute a recording having ZERO azimuth error. Such a recording would exhibit NO losses due to azimuth error when reproduced by another ideal head so aligned, and would provide perfect phase relationship of any one portion of the tape compared to any other portion. (A similarly perfect multi-track reproduce head would be required to demonstrate this condition). In practice, there of course must be tolerances. All heads have some deviation from straightness. Tape slitting tolerance contributes to varying skew of the tape as it plays across the heads. Machines without constant holdback tension will see a varying tension of the tape as the supply reel diameter changes. This also causes skew, with resultant azimuth changes. The narrower the track, the less critical the azimuth. The popular cassette format, with approximately 20 mil tracks, is "saved" by the narrow track at its low tape speed of 1-7/8 ips. A wider track at this speed would have much greater azimuth problems.

The determination of azimuth in the laboratory is quite well described in texts dealing with the general subject, however, we will briefly list the more practical methods.

- (1) Pulse recording with recorded pattern made visible for readout on rather elaborate optical equipment capable of readings to within one minute of arc.
- (2) "Mirror" image techniques, such as winding a high frequency recording on tape face to face with blank tape, exposing to a mild field to produce a printed mirror image. The two tapes are then each reproduced and the error halved, that is, the corrective arc is bisected. The experiment is continued until no correction of playback head azimuth is needed when comparing tapes. This method is cumbersome and seldom used.
- (3) A head is built with accurately coplaner finished front and back gaps. Tape is

drawn across one gap at a time. When maximum output is obtained at both gaps without altering azimuth, recording azimuth is shown to be vertical.

- (4) A near perfect two track head is made to record and play two channels of recording. In this scheme the phase difference is noted when playing back the recording after the tape has been turned over oxide out and the signal is recovered through the base of the tape.
- (5) A so called self proving azimuth tape has been produced having medium wavelength tones deliberately off azimuth by precisely the same amount in each direction. In playing back, the user bisects the error of the two tones, thus making the output equal for each tone. The tape can then be turned over and played through the backing to see if the two tones are still equal in level as they must necessarily be, assuming that the tape was made accurately. This method was also once used with variable density photographic recording where the inherent instability was more tolerable.

MISALIGNMENT AND PHASE ERROR IN TWO-TRACK SYSTEMS

The importance of proper alignment between the tracks in a two track system is critical if a situation arises in which one must sum the outputs of the tracks. Severe phase errors may occur, preventing proper signal summing and consequent distortion.

This particular analysis is limited to a consideration of two systems: (1) The new NAB cartridge (2) The standard two track stereo configuration. Results can be extended easily to multi-track systems by simply cascading the results in (2) above. In this analysis, several simplifying assumptions have been made, which are detailed below:

Assumption A: The angular offset is assumed to exist between the centers of the two tracks.

Assumption B: The angular misalignment is approximated, for the very small angles involved, by a section of circular arc.

Assumption C: The computed angular misalignment is linearly mapped into the sinusoidal flux distribution on the tape for the final result.

Assumption D: The calculations are for 1.01 mil recorded wavelength.

The effect of these assumptions is to introduce small errors in the final results which, however, are not measurable with typical resources available in the laboratory.

These results are summarized in Tables 1 and 2, following. The results have, in each case, been carried out to 20 minutes of arc (one third of a degree). The errors then begin to repeat as multiples of 360° (or close to it). It is instructive to note that misalignments of 17 minutes for the NAB cartridge and 10 minutes for the two track configuration will produce results close to a complete phase reversal. It, therefore, behooves the technician to be very careful when aligning heads and to use an oscilloscope to show lissajous figures. Also, he must ensure that the phase error does not exceed 360° (misalignments of more than 0.5 degrees will produce such gross errors).

TABLE 1

NAB 2 TRACK BROADCAST CARTRIDGE (2 Audio Tracks Plus 1 Cue Track)
 1.0 MIL RECORDED WAVELENGTH (7.5 kHz @ 7½ ips)

Misalignment in minutes of arc	Resultant phase error in degrees between channels
1	11
2	21
3	31
4	42
5	52
6	63
7	73
8	84
9	94
10	105
11	115
12	126
13	136
14	147
15	157
16	168
17	178
18	189
19	200
20	209

TABLE 2
2 TRACK STEREO REEL TO REEL
1.0 MIL RECORDED WAVELENGTH

Misalignment in minutes of arc	Resultant phase error in degrees between channels
1	17.5
2	35.0
3	52.5
4	70.0
5	87.4
6	104.9
7	122.4
8	139.9
9	157.4
10	174.9
11	192.4
12	209.9
13	227.4
14	244.9
15	262.3
16	279.8
17	297.3
18	314.8
19	332.3
20	349.8

THE FOLLOWING CHARTS INDICATE THE LOSS DUE TO AZIMUTH MISALIGNMENT FOR VARIOUS TRACK WIDTHS.

ANY FORMAT MAY BE CALCULATED THROUGH USE OF THE FOLLOWING FORMULA

$$A = 20 \log_{10} \left[\frac{\sin \left(\frac{\pi b \tan a}{\lambda} \right)}{\left(\frac{\pi b \tan a}{\lambda} \right)} \right]$$

where A = loss in decibels;
 b = width of sound track
 a = angle of tilt
 λ = wavelength of recorded signal.

Note: While a may be in degrees the quantity in parenthesis is in radians.

LOSS DUE TO AZIMUTH DISAGREEMENT 250 MIL FULL TRACK					
1 Mil Wave Length		½ Mil Wave Length		¼ Mil Wave Length	
Loss in dB	Azimuth Error in Minutes	Loss in dB	Azimuth Error in Minutes	Loss in dB	Azimuth Error in Minutes
0.5 dB	2.5	0.5 dB	1.3	0.5 dB	0.64
1.0 dB	3.6	1.0 dB	1.8	1.0 dB	0.89
2.0 dB	5.0	2.0 dB	2.5	2.0 dB	1.25
3.0 dB	6.0	3.0 dB	3.0	3.0 dB	1.52
4.0 dB	6.9	4.0 dB	3.5	4.0 dB	1.73
5.0 dB	7.6	5.0 dB	3.8	5.0 dB	1.91
6.0 dB	8.3	6.0 dB	4.0	6.0 dB	2.07
7.0 dB	8.8	7.0 dB	4.4	7.0 dB	2.20
8.0 dB	9.3	8.0 dB	4.7	8.0 dB	2.33
9.0 dB	9.7	9.0 dB	4.9	9.0 dB	2.43
10.0 dB	10.0	10.0 dB	5.0	10.0 dB	2.53

LOSS DUE TO AZIMUTH DISAGREEMENT 75 MIL TWO TRACK					
1 Mil Wave Length		½ Mil Wave Length		¼ Mil Wave Length	
Loss in dB	Azimuth Error in Minutes	Loss in dB	Azimuth Error in Minutes	Loss in dB	Azimuth Error in Minutes
0.5 dB	8.52	0.5 dB	4.26	0.5 dB	2.13
1.0 dB	11.98	1.0 dB	5.99	1.0 dB	2.99
2.0 dB	16.75	2.0 dB	8.37	2.0 dB	4.18
3.0 dB	20.27	3.0 dB	10.13	3.0 dB	5.06
4.0 dB	23.12	4.0 dB	11.56	4.0 dB	5.78
5.0 dB	25.53	5.0 dB	12.76	5.0 dB	6.38
6.0 dB	27.61	6.0 dB	13.80	6.0 dB	6.90
7.0 dB	29.44	7.0 dB	14.72	7.0 dB	7.36
8.0 dB		8.0 dB	15.53	8.0 dB	7.76
9.0 dB		9.0 dB	16.26	9.0 dB	8.13
10.0 dB		10.0 dB	16.91	10.0 dB	8.45

LOSS DUE TO AZIMUTH DISAGREEMENT 43 MIL QUARTER TRACK					
1 Mil Wave Length		½ Mil Wave Length		¼ Mil Wave Length	
Loss in dB	Azimuth Error in Minutes	Loss in dB	Azimuth Error in Minutes	Loss in dB	Azimuth Error in Minutes
0.5 dB	14.86	0.5 dB	7.43	0.5 dB	3.71
1.0 dB	20.90	1.0 dB	10.45	1.0 dB	5.22
2.0 dB	29.21	2.0 dB	14.60	2.0 dB	7.30
3.0 dB		3.0 dB	17.67	3.0 dB	8.83
4.0 dB		4.0 dB	20.16	4.0 dB	10.08
5.0 dB		5.0 dB	22.16	5.0 dB	11.13
6.0 dB		6.0 dB	24.08	6.0 dB	12.04
7.0 dB		7.0 dB	25.68	7.0 dB	12.84
8.0 dB		8.0 dB	27.09	8.0 dB	13.54
9.0 dB		9.0 dB	28.36	9.0 dB	14.18
10.0 dB		10.0 dB	29.50	10.0 dB	14.75

dB LOSS vs. MINUTES AZIMUTH ERROR AT 15kHz FOR SEVERAL COMMON RECORDING FORMATS

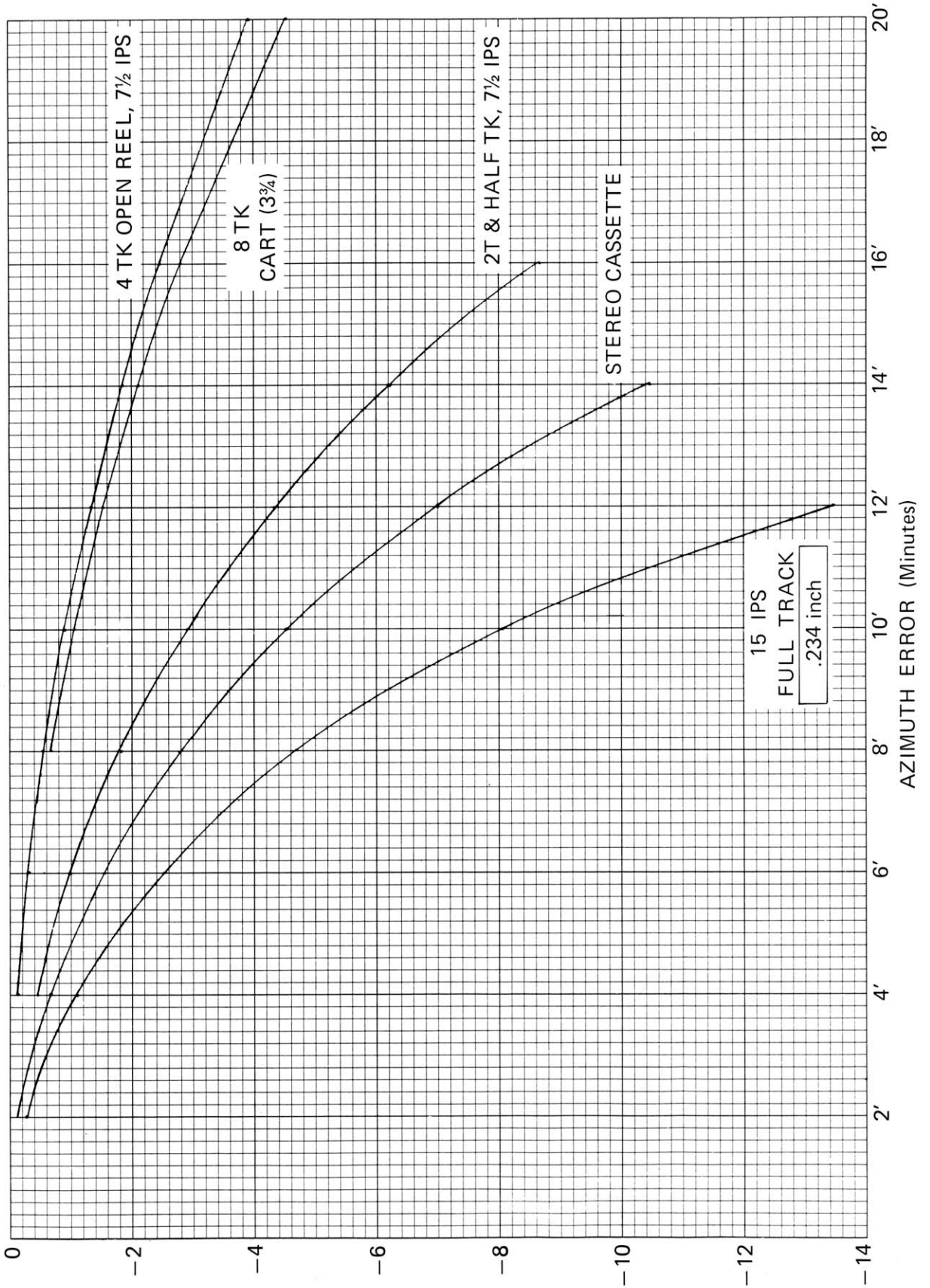

SECTION 4

Loop Response Measurements and Playback Amplifier Curves

The following pages present curves showing the standard induction loop response for various reproducer characteristics described in terms of time constants. Much confusion has occurred as to the relationship of the amplifier [alone] curve to the induction loop-head-amplifier curve. It is helpful to keep in mind that in a system having no gap, spacing, or recording process losses, a recording made by means of constant current, and subsequently reproduced through an amplifier having no frequency compensation, i.e. flat, would produce a signal rising 6 dB per octave. Normal repro. amplifiers are basically of the opposite characteristic, with a drop of 6 dB per octave over the audio spectrum *plus* whatever modification is called out in the particular standard for a given speed and application. The expression in "time constants" has been common in communications work (Radio, for example, 75 microsec. preemphasis in FM). The curve is defined by the time constant of the required values of resistor and capacitor components in the RC equalizer circuit. One must ALWAYS remember that the standard refers to equalization ADDED to the normal 6 dB/octave repro. curve. Therefore, the transition frequency reference is convenient to indicate where the curve DEPARTS from the 6 dB slope. (REFER TO THE 7.5 IPS 50 MICROSECOND AMPLIFIER CURVE* AND NOTE THE DEPARTURE FROM A STRAIGHT LINE AT 50Hz, AND AT 3200Hz.) The "3 dB" points can be expressed in terms of transition frequencies of 50Hz, and 3200Hz. To quickly illustrate the relationship of a loop response curve to an amplifier only curve, note that the loop response chart calls out plus 10.36 dB at 10kHz for the 7½-15 ips 3180 & 50 microsecond standard. Now look at the *amplifier only* response curve and note that the 10kHz point is NOT THE SAME. If you now place a straight edge along the straight part of the amplifier curve, and COUNT UP FROM THE STRAIGHT EDGE TO THE 10kHz POINT you will read the same 10.36 dB as shown in the induction-loop response. PLEASE forgive the harping on this point but MANY experienced people fail to realize that you cannot simply turn OVER the loop response chart and see the amplifier curve.

Amplifier response can be plotted from loop response by simply drawing a 6dB/octave line and adding to this line the amount by which the loop response figure deviates from the 0 dB reference. See examples below:

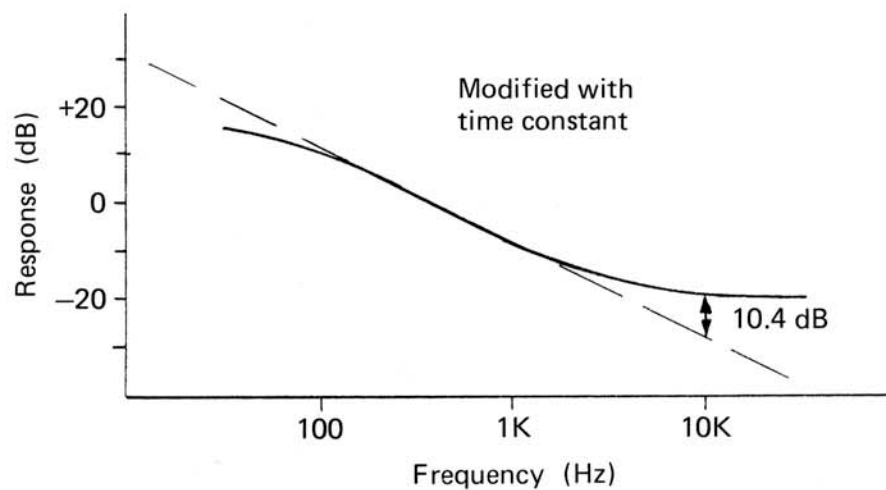
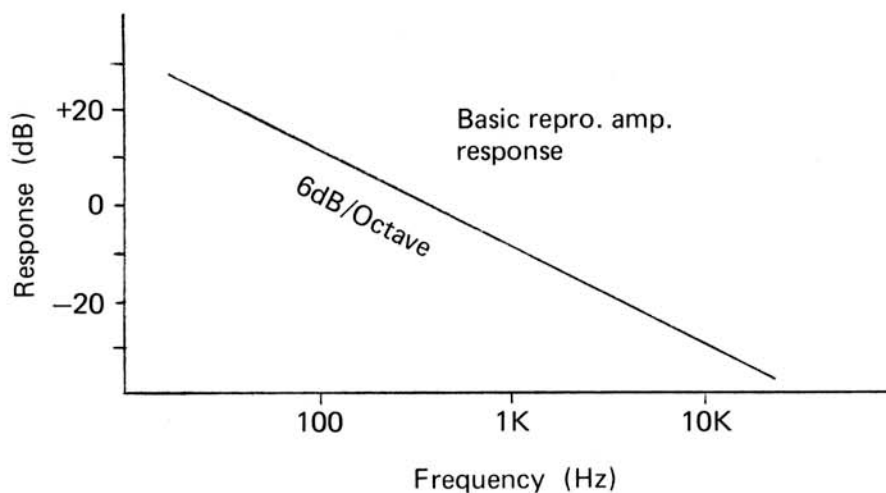

NOTE: in case of 50 microsecond response, PB amp. is displaced by 10.4dB from a straight 6dB/oct. slope at 10kHz. Loop response is 10.4dB above Zero reference.

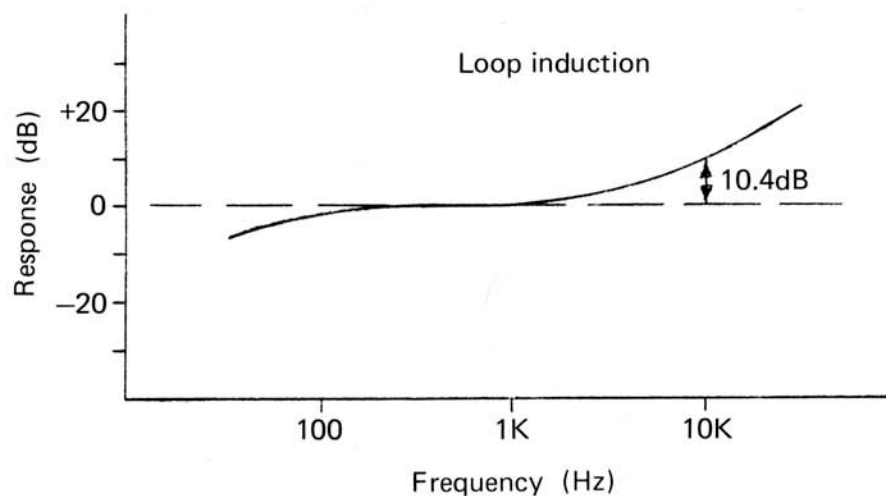

SECTION 5

Reproducer Characteristics

Loop Response

Amplifier Response

The following response curves will supply needed data for the common tape speeds. Both the old (1590 and 120 microsecond) cassette curve and the newer (3180 and 120) are shown. Various combinations can be derived when needed. The "Chrome" and certain high energy cassette tapes employ 70 microseconds for high end equalization with a 3180 microsecond low end equalization. The 7½ ips European curve provides a 70 microsecond top and that curve may be helpful in adjusting a cassette "chrome" equalizer. The 3180 microsecond low end can be seen in the curves for 7½, 15 ips, NAB.

AES STANDARD REPRODUCING CHARACTERISTIC

30 ips (17.5 μ s)Reproducing Amplifier Output for Constant Flux
in the Core of an Ideal Reproducing Head

Frequency	Response	Frequency	Response
20 Hz	+ .00002	1.5 kHz	+ .11658
25	.00003	2	.20513
30	.00005	2.5	.31640
40	.00008	3	.44863
50	.00013	4	.76811
60	.00019	5	1.14709
70	.00026	6	1.56944
75	.00030	7	2.02079
80	.00034	7.5	2.25351
90	.00043	8	2.48923
100	.00053	9	2.96541
150	.00118	10	3.44231
200	.00210	11	3.91483
250	.00328	12	4.37943
300	.00472	13	4.83375
400	.00839	14	5.27628
500	.01311	15	5.70619
600	.01866	16	6.12306
700	.02566	17	6.52684
750	.02944	18	6.91765
800	.03348	19	7.29580
900	.04233	20 kHz	+ 7.66168
1 kHz	+ .05220		

AES STANDARD REPRODUCING CHARACTERISTIC

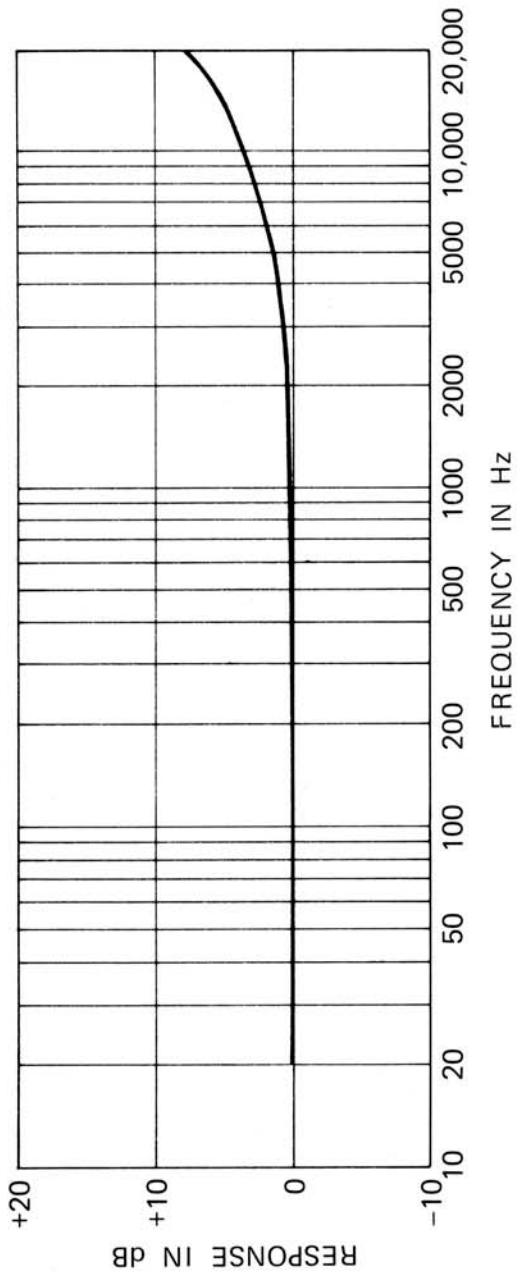
30 ips (17.5 μ s)

AES AMPLIFIER PLAYBACK CHARACTERISTIC

30 ips (17.5 μ s)

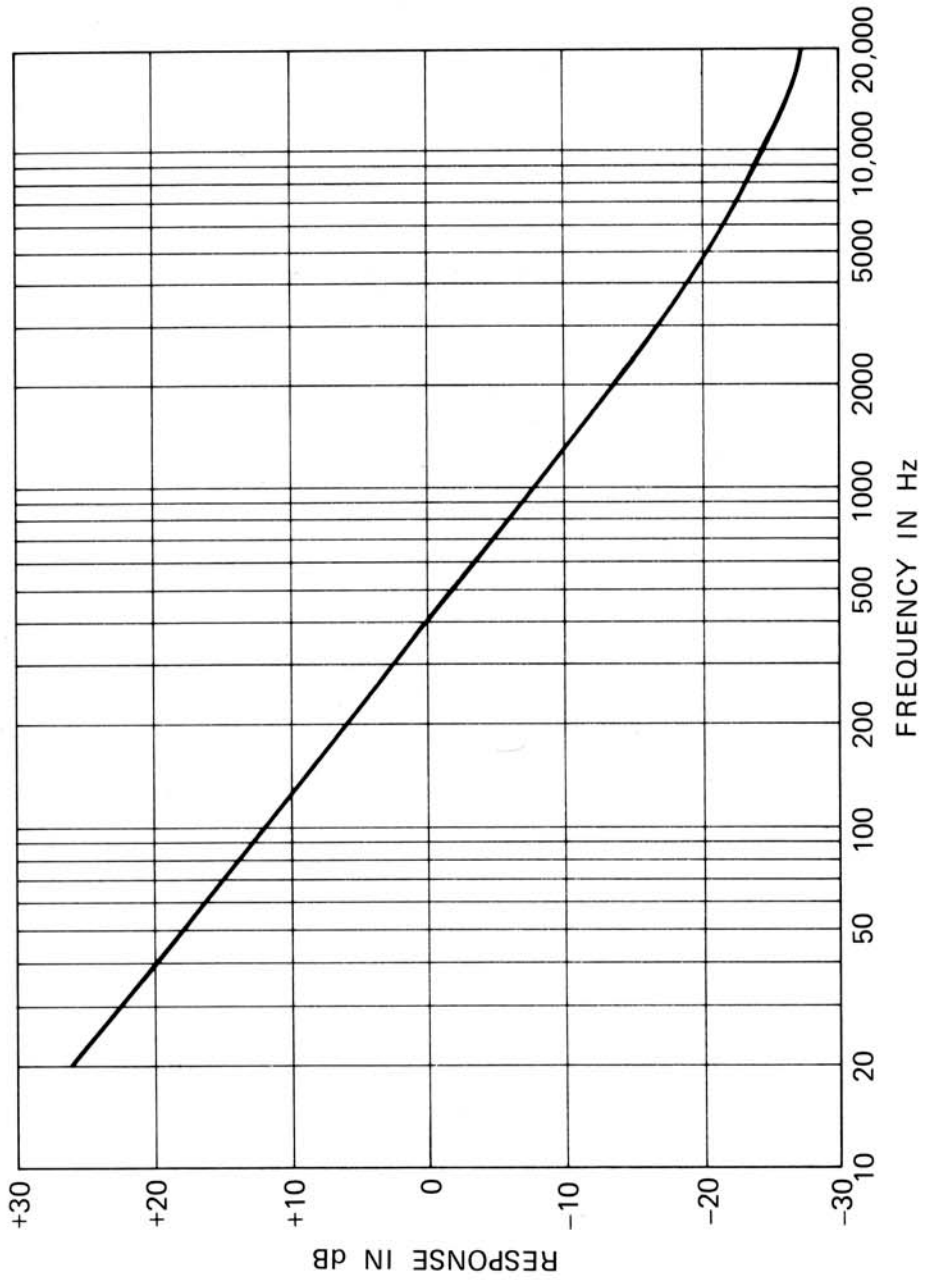

NAB STANDARD REPRODUCING CHARACTERISTIC7½ and 15 ips (3180 and 50 μ s)Reproducing Amplifier Output for Constant Flux
in the Core of an Ideal Reproducing Head

Frequency	Response	Frequency	Response
20 Hz	– 8.6105	1.5 kHz	+ .86611
25	6.9962	2	1.44235
30	5.7782	2.5	2.08495
40	4.0911	3	2.75941
50	3.01346	4	4.11406
60	2.29219	5	5.39960
70	1.79111	6	6.58272
75	1.59720	7	7.66100
80	1.43173	7.5	8.16331
90	1.16673	8	8.64289
100	.96650	9	9.53957
150	.44878	10	10.36202
200	.24667	11	11.11999
250	.14395	12	11.82185
300	.08081	13	12.47466
400	+ .00058	14	13.08439
500	.06255	15	13.65606
600	.12151	16	14.19392
700	.18296	17	14.70159
750	.21535	18	15.18214
800	.24904	19	15.63825
900	.32060	20 kHz	+ 16.07220
1 kHz	+ .39791 db		

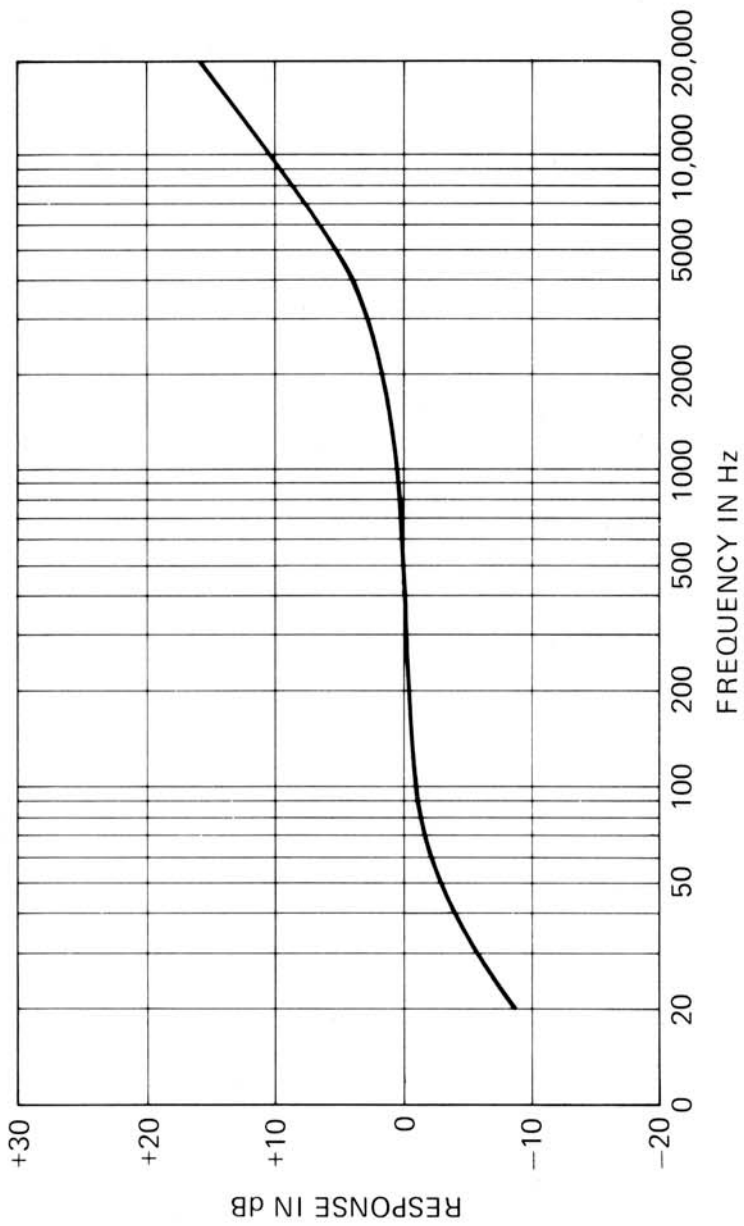
REPRODUCING CHARACTERISTIC, NAB7.5 and 15 ips (3180 and 50 μ s)

NAB AMPLIFIER PLAYBACK CHARACTERISTIC

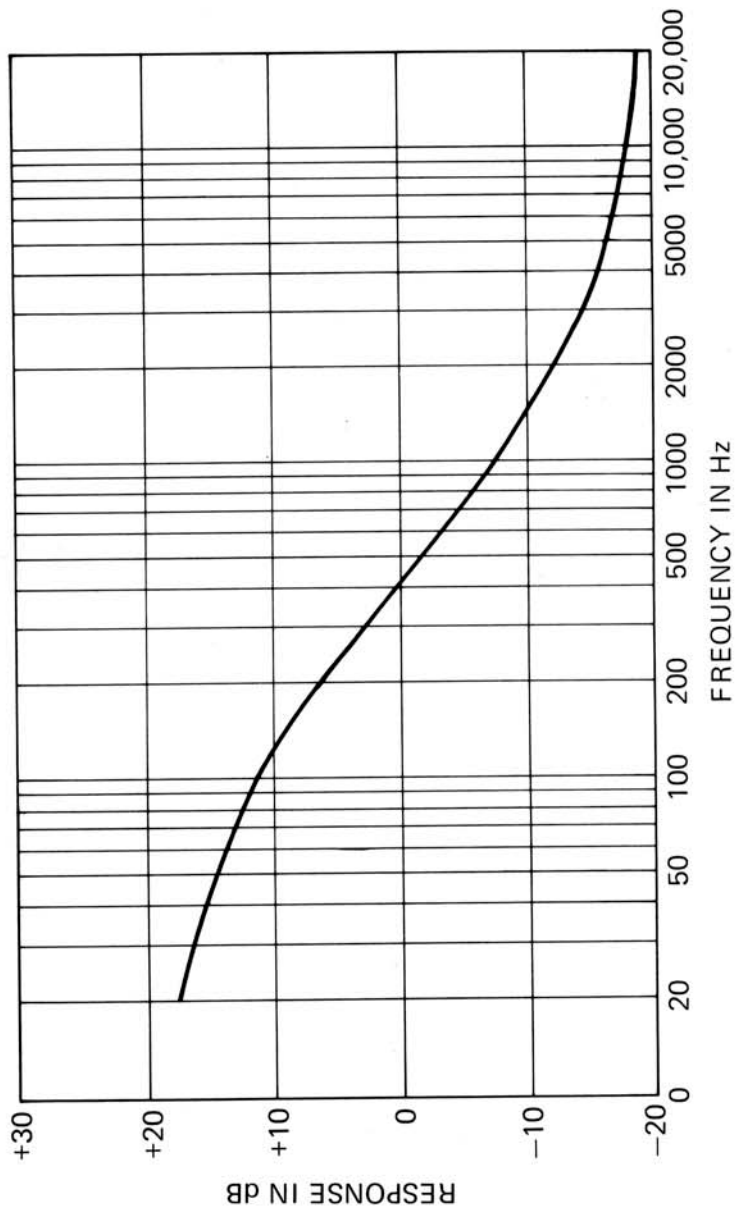
7.5 and 15 ips (3180 and 50 μ s)

I.E.C./CCIR STANDARD REPRODUCING CHARACTERISTIC

15 and 30 ips (35 μ sec)

Reproducing Amplifier Output for Constant Flux
in the Core of an Ideal Reproducing Head

Frequency	Response	Frequency	Response
20 Hz	+ .00008	1.5 kHz	+ .44863
25	.00013	2	.76810
30	.00018	2.5	1.14709
40	.00033	3	1.56943
50	.00052	4	2.48922
60	.00075	5	3.44230
70	.00102	6	4.37943
75	.00118	7	5.27628
80	.00134	7.5	5.70618
90	.00170	8	6.12306
100	.00210	9	6.91765
150	.00472	10	7.66168
200	.00839	11	8.35843
250	.01310	12	9.01178
300	.01886	13	9.62560
400	.03347	14	10.20359
500	.05219	15	10.74911
600	.07496	16	11.26520
700	.10172	17	11.75456
750	.11657	18	12.21960
800	.13239	19	12.66244
900	.16689	20 kHz	+ 13.08497
1 kHz	+ .20513		

CCIR STANDARD REPRODUCING CHARACTERISTIC

15 and 30 ips (35 μ s)

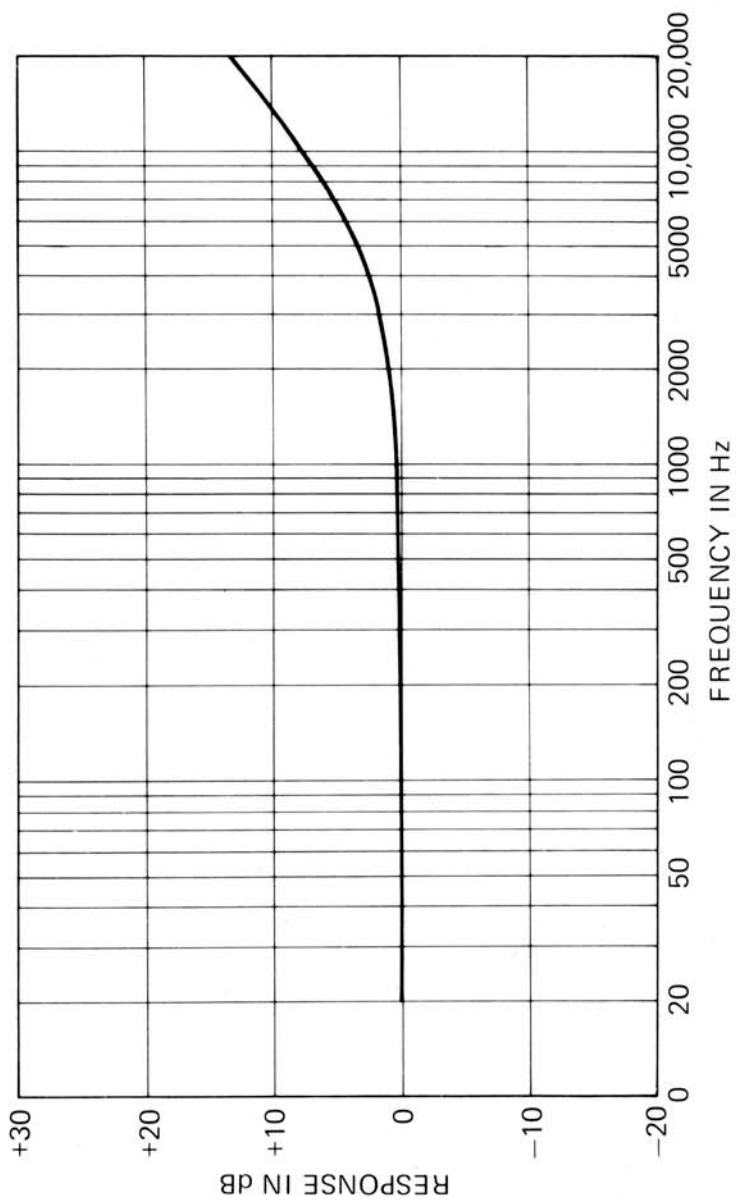

CCIR AMPLIFIER PLAYBACK CHARACTERISTIC

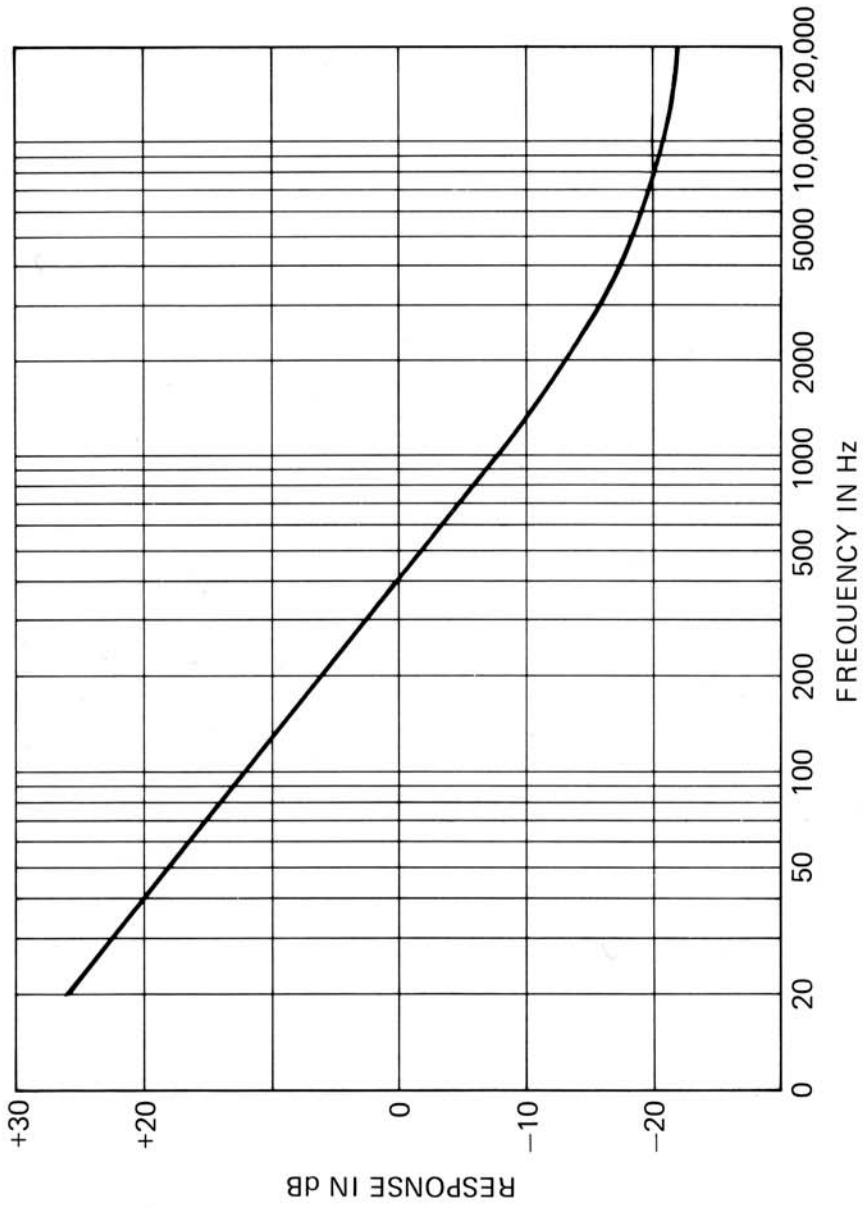
15 and 30 ips (35 μ s)

I.E.C./CCIR STANDARD REPRODUCING CHARACTERISTIC

7.5 ips (70 μ sec)

Reproducing Amplifier Output for Constant Flux
in the Core of an Ideal Reproducing Head

Frequency	Response	Frequency	Response
20 Hz	+ .00033	1.5 kHz	+ 1.57001
25	.00052	2	2.49006
30	.00075	2.5	3.44335
40	.00134	3	4.38064
50	.00210	4	6.12450
60	.00302	5	7.66326
70	.00411	6	9.01345
75	.00472	7	10.20532
80	.00537	7.5	10.75086
90	.00680	8	11.26697
100	.00839	9	12.22139
150	.01887	10	13.08678
200	.03349	11	13.8774
250	.05222	12	14.60472
300	.07500	13	15.27765
400	.13245	14	15.90356
500	.20522	15	16.48843
600	.29253	16	17.03718
700	.39351	17	17.55394
750	.44882	18	18.04216
800	.50717	19	18.50479
900	.63250	20 kHz	+ 18.94436
1 kHz	+ .76841		

INDUCTION LOOP – CCIR STANDARD REPRODUCING CHARACTERISTIC

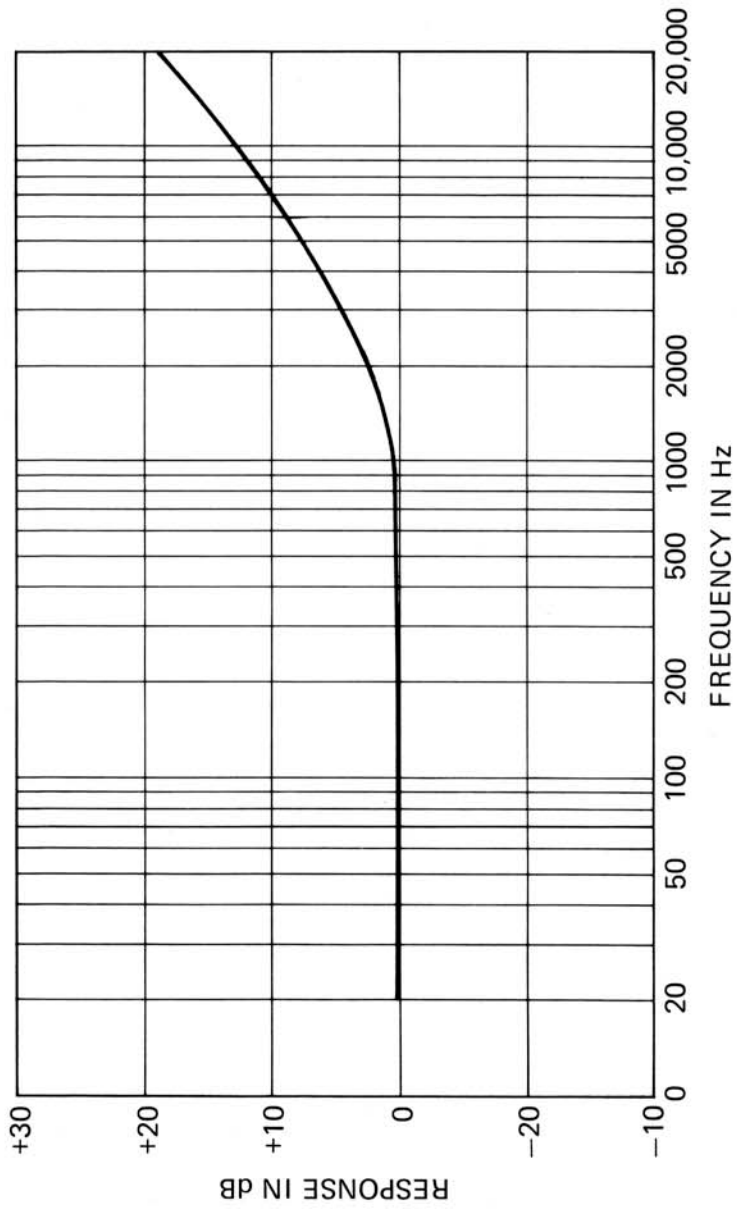
7.5 ips (70 μ s)

CCIR AMPLIFIER PLAYBACK CHARACTERISTIC

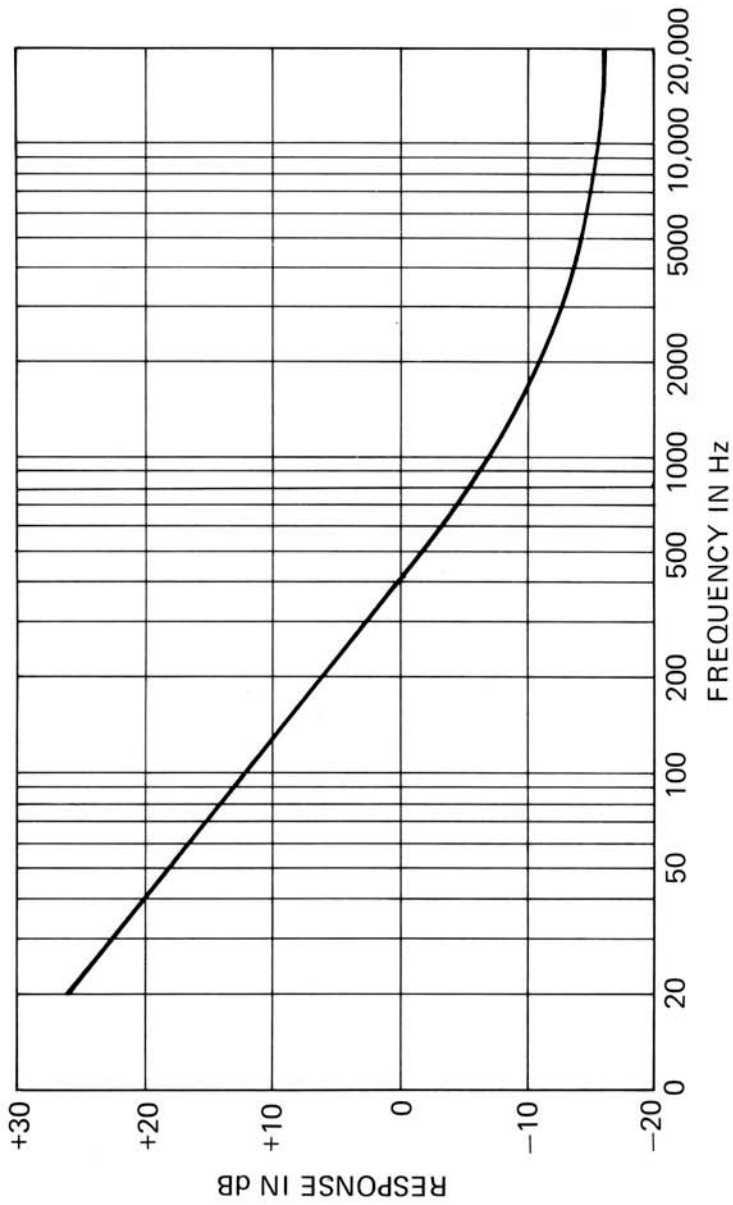
7.5 ips (70 μ s)

NAB STANDARD REPRODUCING CHARACTERISTIC1 ⁷/₈ and 3 ³/₄ ips (3180 and 90 μ s)Reproducing Amplifier Output for Constant Flux
in the Core of an Ideal Reproducing Head

Frequency	Response	Frequency	Response
20 Hz	- 8.61011 db	1.5 kHz	+ 2.34917
25	6.99560	2	3.57491
30	5.77733	2.5	4.76743
40	4.08957	3	5.88484
50	3.01106	4	7.86428
60	2.28874	5	9.53927
70	1.78641	6	10.97293
75	1.59180	7	12.21886
80	1.42559	7.5	12.78445
90	1.15897	8	13.31726
100	.95692	9	14.29767
150	.42728	10	15.18207
200	.20858	11	15.98702
250	.08471	12	16.72530
300	+ .00400	13	17.40687
400	.14924	14	18.03969
500	.29071	15	18.63016
600	.44309	16	19.18353
700	.61002	17	19.70412
750	.69905	18	20.19558
800	.79166	19	20.66094
900	.98690	20 kHz	21.10284
1 kHz	1.19413 db		

INDUCTION LOOP – REPRODUCING CHARACTERISTIC, NAB
1.875 and 3.750 ips (3180 and 90 μ s)

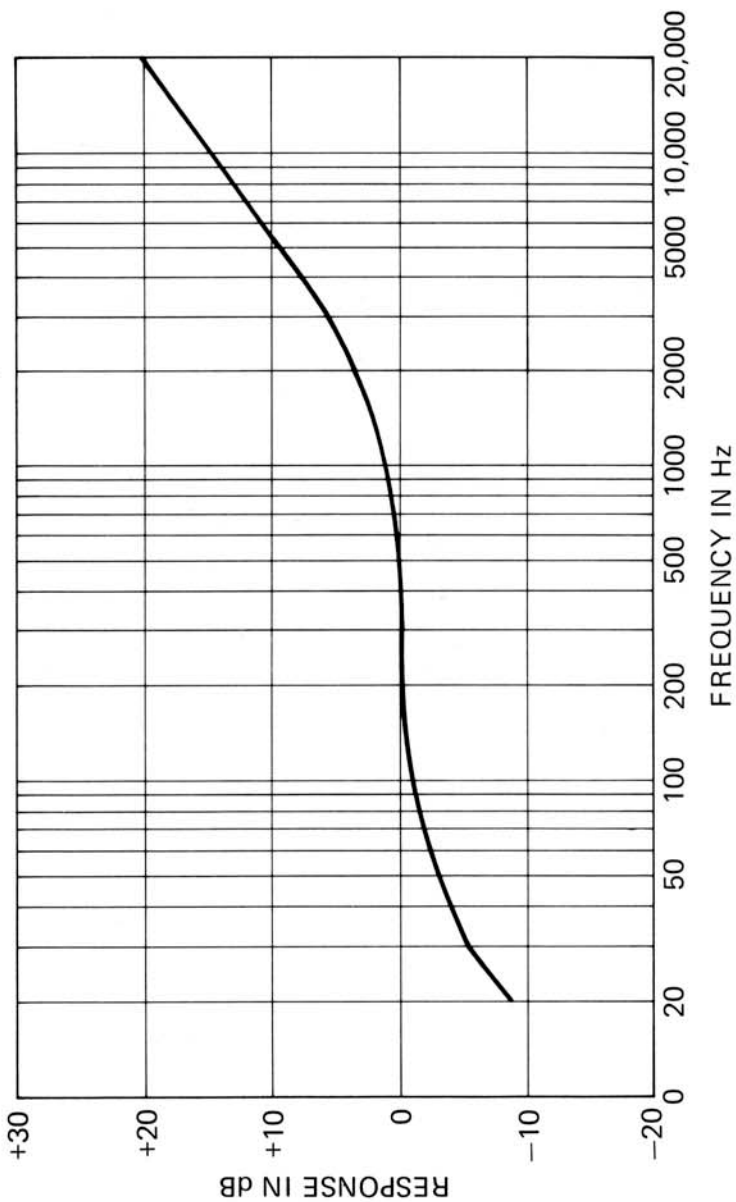

NAB AMPLIFIER PLAYBACK CHARACTERISTIC

1.875 and 3.750 ips (3180 and 90 μ s)

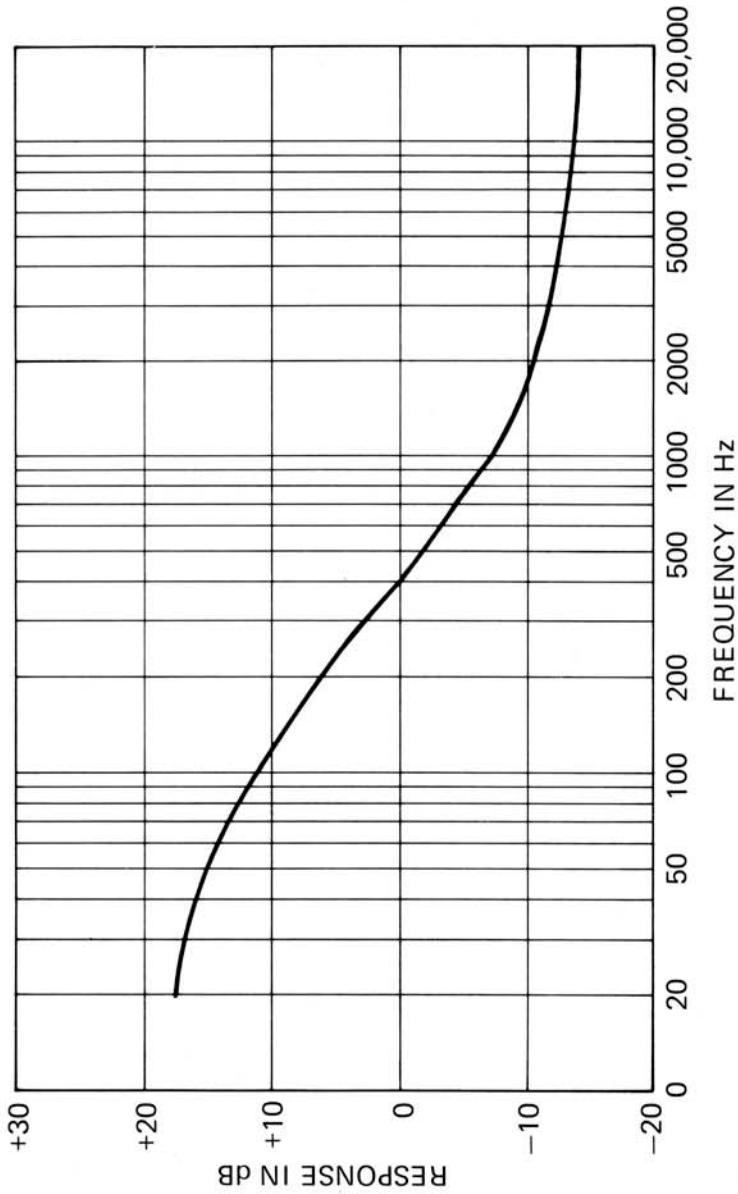

REPRODUCING CHARACTERISTIC 1.875 ips PHILLIPS CASSETTE
 (1590 and 120 μ s)

Reproducing Amplifier Output for Constant Flux
 in the Core of an Ideal Reproducing Head

Frequency	Response	Frequency	Response
20 Hz	- 14.15688	1.5 kHz	+ 3.55833
25	12.31090	2	5.13986
30	10.83738	2.5	6.57607
40	8.60672	3	7.86012
50	6.99030	4	10.03870
60	5.76970	5	11.82018
70	4.82350	6	13.31622
75	4.42852	7	14.60146
80	4.07602	7.5	15.18140
90	3.47665	8	15.72609
100	2.98991	9	16.72483
150	1.54441	10	17.62251
200	0.87314	11	18.43739
250	0.49411	12	19.18327
300	- 0.24171	13	19.87080
400	+ 0.11429	14	20.50836
500	0.40646	15	21.10267
600	0.68940	16	21.65919
700	0.97930	17	22.18240
750	1.12832	18	22.67605
800	1.28014	19	23.14328
900	1.59155	20 kHz	+ 23.58677
1 kHz	+ 1.91151		

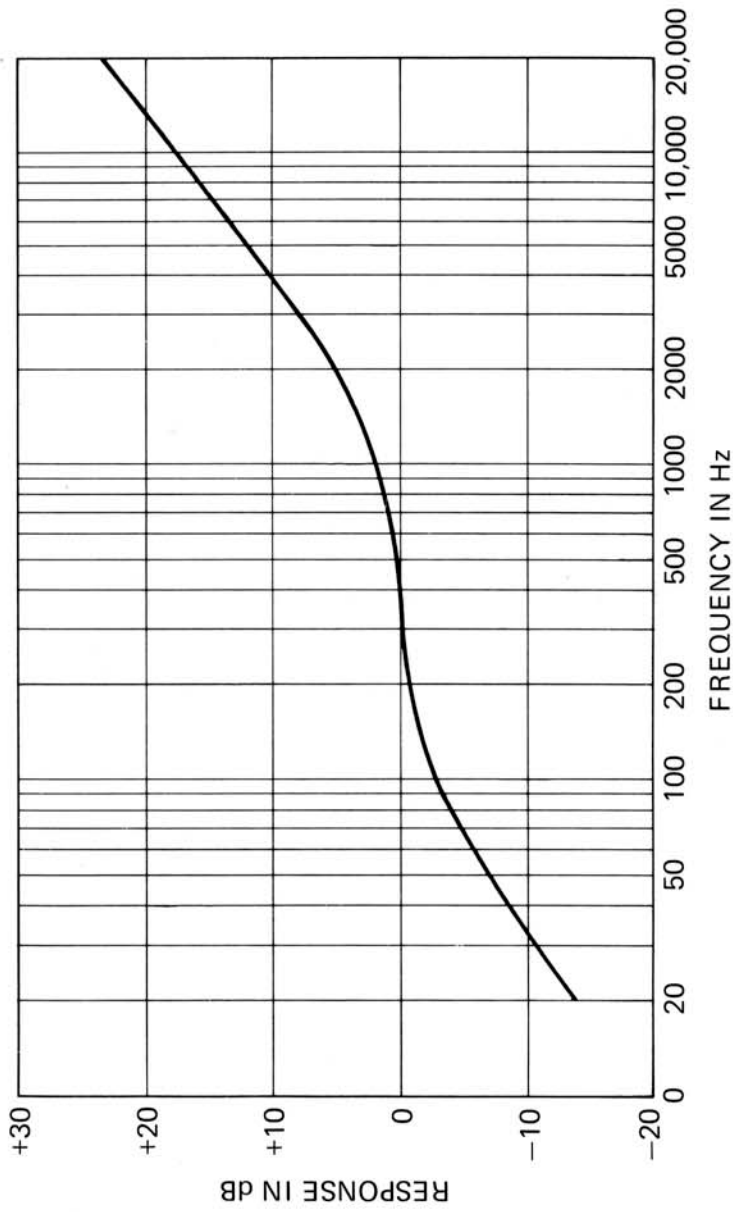
INDUCTION LOOP – REPRODUCING CHARACTERISTIC1.875 ips Phillips Cassette (1590 and 120 μ s)

LATEST CASSETTE REPRODUCING CHARACTERISTIC

1.875 ips (120 μ s)

Reproducing Amplifier Output for Constant Flux
in the Core of an Ideal Reproducing Head

Frequency	Response	Frequency	Response
20 Hz	-8.60969	1.5 kHz	+ 3.57280
25	6.99493	2	5.14801
30	5.77636	2.5	6.58129
40	4.08785	3	7.86375
50	3.00836	4	10.04074
60	2.28486	5	11.82149
70	1.78114	6	13.31713
75	1.58575	7	14.60213
80	1.41871	7.5	15.18199
90	1.15025	8	15.72661
100	0.94617	9	16.72524
150	0.40322	10	17.62284
200	0.16614	11	18.43767
250	0.01903	12	19.18350
300	+0.09748	13	19.87100
400	0.31062	14	20.50853
500	0.53383	15	21.10282
600	0.77852	16	21.65932
700	1.04507	17	22.18252
750	1.18570	18	22.67615
800	1.33065	19	23.14337
900	1.63154	20	23.58685
1 kHz	1.94395		

INDUCTION LOOP – REPRODUCING CHARACTERISTIC
1.875 ips (3180 and 120 μ s)

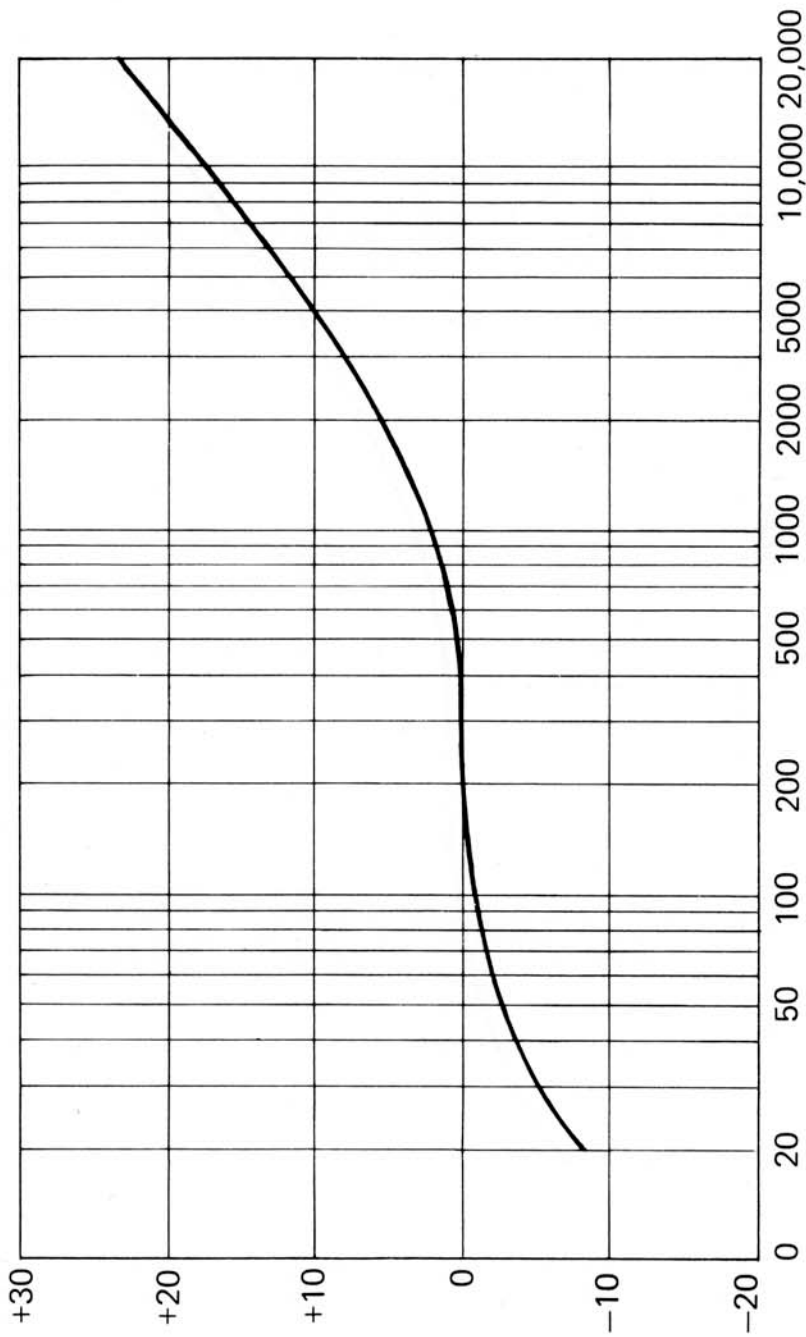

AMPLIFIER PLAYBACK CHARACTERISTIC
1.875 ips Phillips Cassette (3180 and 120 μ s)

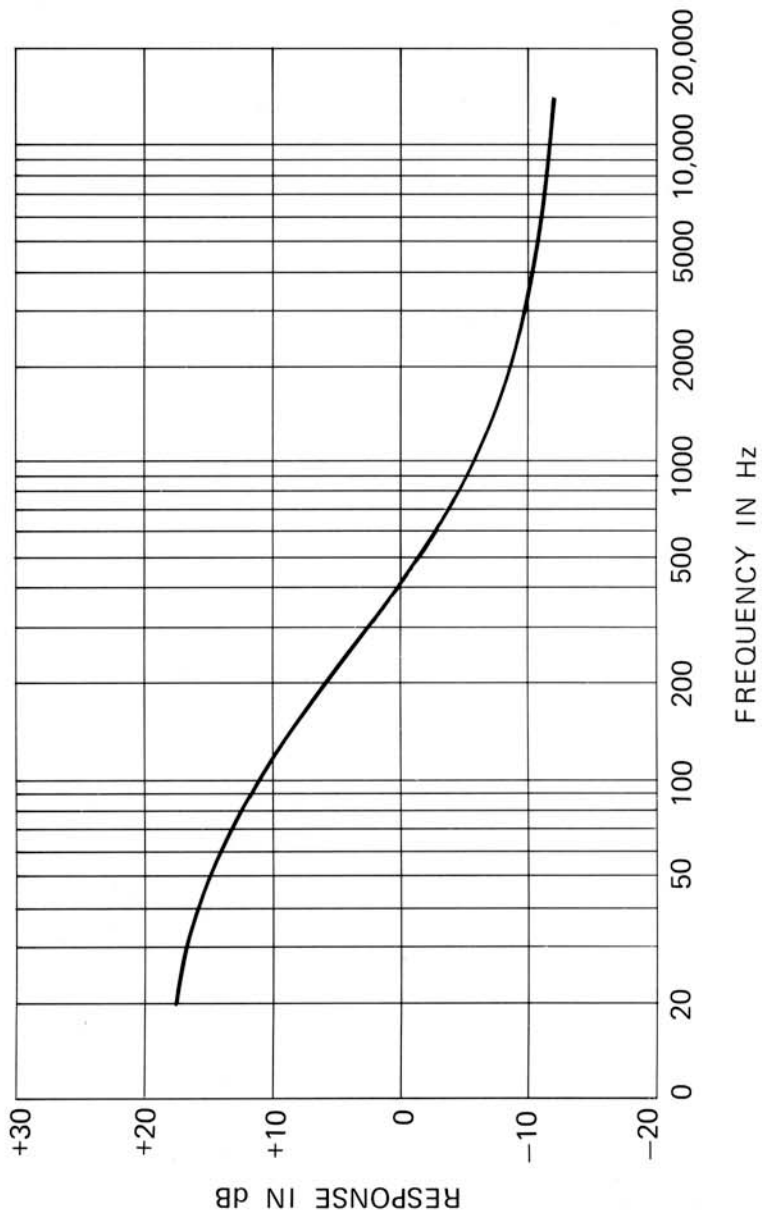

SECTION 6

Wavelength Charts

		TAPE SPEED, ips					
		30	15	7 1/2	3 3/4	1 7/8	15/16
30	kHz	.025	.013	.006			
20	kHz	.038	.019	.010	.005		
15	kHz	.051	.025	.013	.006	.003	
12	kHz	.064	.032	.016	.008	.004	
10	kHz	.076	.038	.019	.010	.005	
8	kHz	.095	.048	.024	.012	.006	
7.5	kHz	.102	.051	.025	.013	.006	.003
5	kHz	.152	.076	.038	.019	.010	.005
4	kHz	.203	.102	.051	.025	.013	.006
3	kHz	.254	.127	.064	.032	.016	.008
1.875	kHz	.406	.203	.102	.051	.025	.013

WAVELENGTH (mm)

		TAPE SPEED, ips					
		30	15	7 1/2	3 3/4	1 7/8	1 5/16
30	kHz	1.0	.500	.250			
20	kHz	1.5	.750	.375	.187		
15	kHz	2.0	1.0	.500	.250	.125	
12	kHz	2.5	1.25	.625	.312	.156	
10	kHz	3.0	1.5	.750	.375	.187	
8	kHz	3.75	1.87	.937	.468	.234	
7.5	kHz	4.0	2.0	1.0	.500	.250	.125
5	kHz	6.0	3.0	1.5	.750	.375	.188
4	kHz	8.0	4.0	2.0	1.0	.500	.250
3	kHz	10.0	5.0	2.5	1.25	.625	.312
1.875	kHz	16.0	8.0	4.0	2.0	1.0	.500

WAVELENGTH (MILS)

SECTION 7

Practical Techniques of Measurement

HOW TO MAKE INDUCTION LOOP MEASUREMENTS OF A REPRODUCE CHANNEL

Induction loop response measurements utilizing a single turn of wire parallel to the reproduce head gap are frequently mentioned in standards recommendations and the literature in general. Before describing the technique, and practical methods of performing the measurements, we should state what the test will and will NOT achieve. Properly performed induction loop response measurements *will* provide data relative to the electrical characteristics of the system. Included will be useful data pertinent to head resonance, playback amplifier response, and core losses of a specific head. The technique will NOT provide data relative to spacing loss, (i.e. tape to head contact), gap loss of the head itself, "head bumps" due to the physical design of the head, nor losses due to misalignment. The distinction between a "standardized" reproduce channel with an IDEAL repro. head, and a channel adjusted to vary from the ideal electrical characteristic to compensate for the imperfections of a practical head must be understood. The common 7½ ips 50 and 3180 micro sec, NAB curve would call for an induction loop response showing a 13.6 dB rise at 15kHz referenced to 400Hz, and a 3 dB drop at 50Hz. In employing a practical head, there will usually be some gap loss and this must be compensated for, although the deviation from "ideal" in repro. heads is becoming quite small. A good head supplied for the purpose above might show a deviation of only a dB or two at the upper and lower frequency extremes. The present tendency with the shorter gap spacers being employed is to find most of the deviation at the low end—due to head bumps resulting from core design shape. Some core loss is to be expected, but this will show up in the induction loop measurements.

SECTION 7 – 2

The following technique for loop response measurements may be conveniently employed in most laboratory or shop environments. In addition to the reproduce amplifier and playback head, you will need the following:

Two VTVM's

An audio oscillator

A short piece of small diameter
enameled wire

Leads to connect as follows:
(See drawing)

A resistor (10 ohms is fine)

METHOD FOR INDUCTION LOOP MEASUREMENT

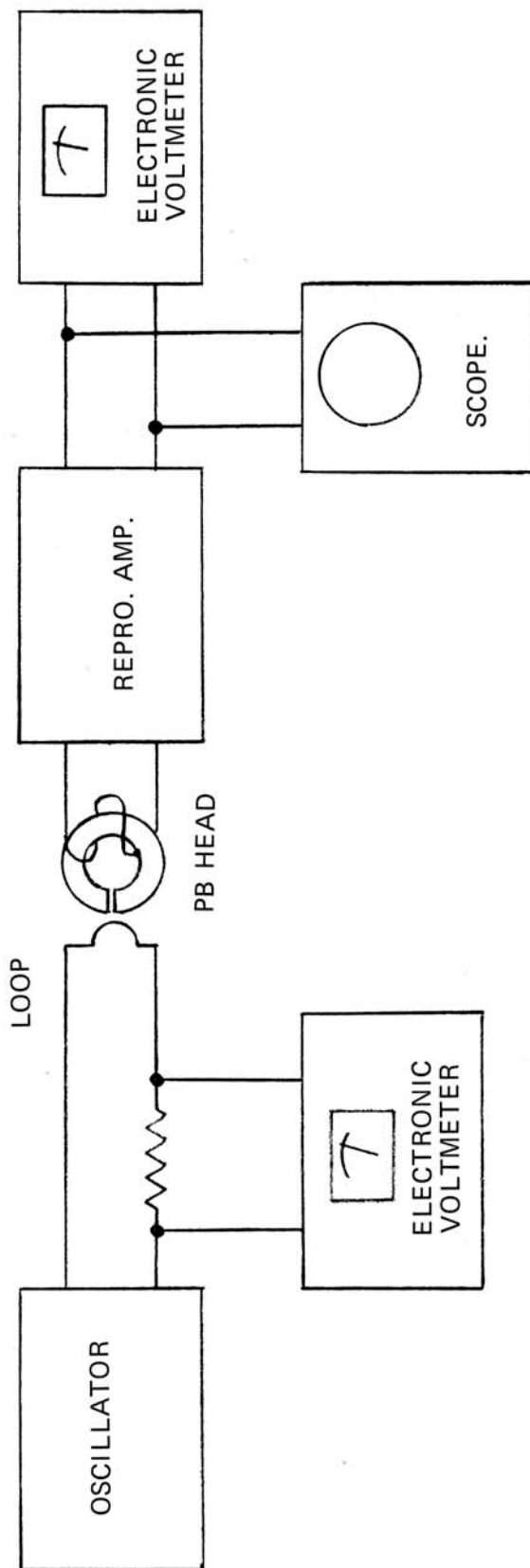

A single piece of wire is positioned up against the head with attention given to secure it in a parallel relationship to the gap. It should be as close as possible to the gap. Obviously, care should be taken not to scratch the head, and therefore, you may want to put a layer of masking tape over the head's surface and then secure the wire with another piece of tape. If loop measurements are to be made frequently, you will appreciate the convenience of a spring clip jig or holder for the wire such as the one illustrated on page 5. Such a device can be easily fabricated and quickly attached or detached. Since heads come in many sizes, you will have to make a loop holder to fit the type of head stack involved. Notice that the wire can be laid in a groove of plastic material in such a way to insure that the head surface cannot be scratched. A piece of masking tape can be permanently left on the holder to protect the head.

Some added considerations:

- (1) The response is not affected by the "azimuth" relationship of the wire to the tape head gap, however maximum signal will result from careful placement as above.
- (2) The usual audio oscillator will only provide a signal at 400Hz of sufficient strength to produce a ZERO reading on about the -30 dB scale of the voltmeter which is connected to the output of the playback amplifier.
- (3) It is best to make the measurements with the level control on the playback amplifier set in the normal position for two reasons: (a) Some equipment may vary slightly in response at different level settings. (b) The induction loop will show a rising response with frequency, and if the 400Hz reference were set to ZERO on equipment having a time constant of say 120 microsec, the high frequency region of measurement could easily produce amplifier clipping resulting in a misleading reading. I have personally encountered two such cases resulting from the above problem; both happened in professional areas, one a laboratory, the other a large recording company's engineering facility. The best policy is to include a 'scope at the amplifier output and watch for any clipping. You may wish to measure a channel that has been adjusted to reproduce a test tape with flat response. Provided the tape is accurate, the result of a loop response test will indicate how much compensation was necessary to make up for gap, spacing, core, and geometric losses in the head.

Another possible use for the loop response test would involve the calibration of a reproduce alignment tape by means of a known reproduce head. By "known", we mean a head that has been measured carefully to determine its actual core, gap and contour deviations from ideal. With such a head connected to a repro. amp which has been corrected for these head losses, a reproduce alignment tape can be examined for agreement. We have found, incidentally, that the most reliable data result from use of heads which are made to be as near "ideal" as possible. One reason, other than the fact that any error involving a large correction factor usually results in a large error, is that heads departing from "ideal" by a wide margin often make measurements very uncertain. Best case in point would be the use of a 300 micro inch repro. head to calibrate a tape's short wavelength recordings. The readings would be unsteady and the measurement, therefore, uncertain. There was a tendency, unfortunately, for some standards committees, in the past, to use components with gross deficiencies when determining measurements of recorded materials. Often the corrections, each with its own inevitable error of measurement, compounded to provide a mathematical treatise of many pages, representing an experiment that was probably un-

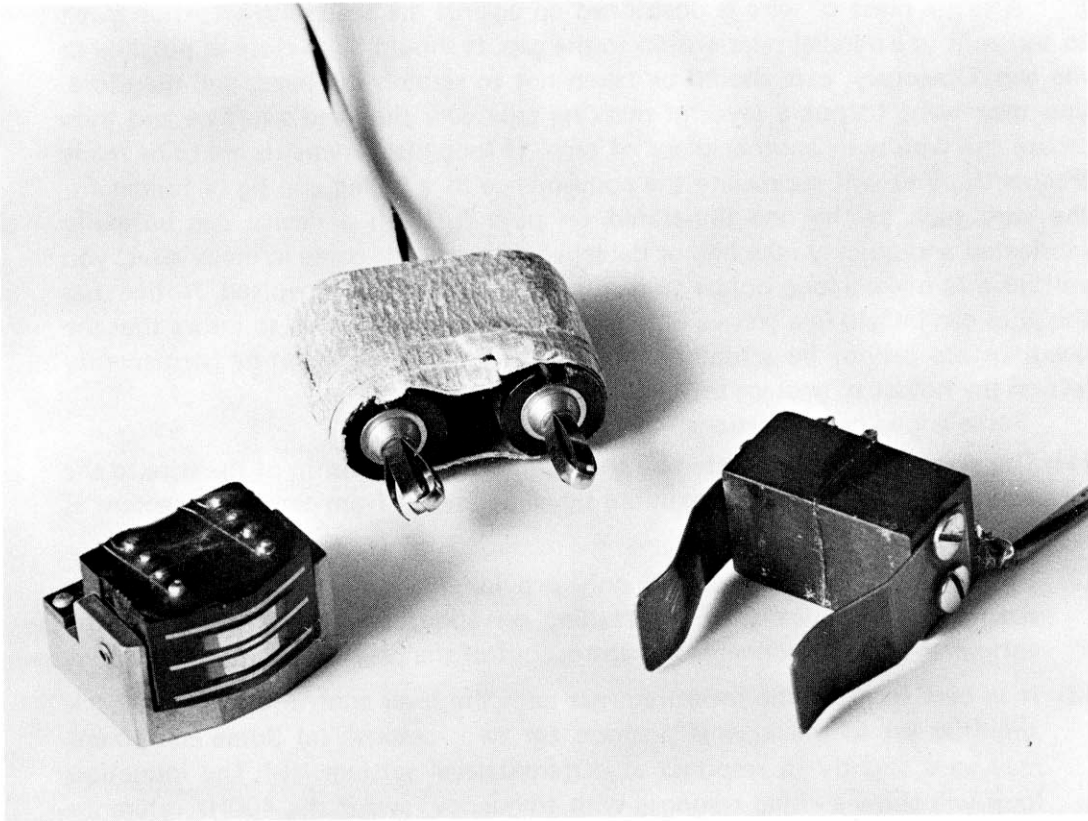

One turn wire fits in groove in plastic block.



Induction loop jig is held in place by means of spring clips.

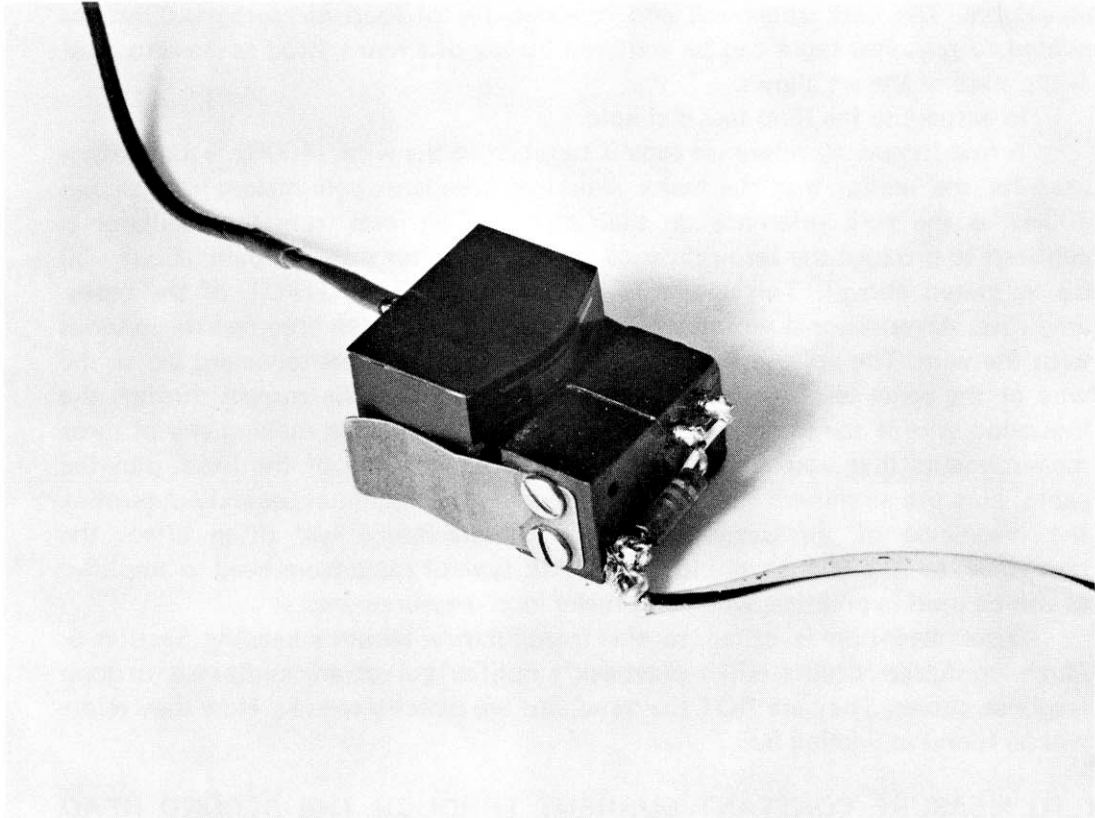

Resistor and extra leads facilitate current measurement.

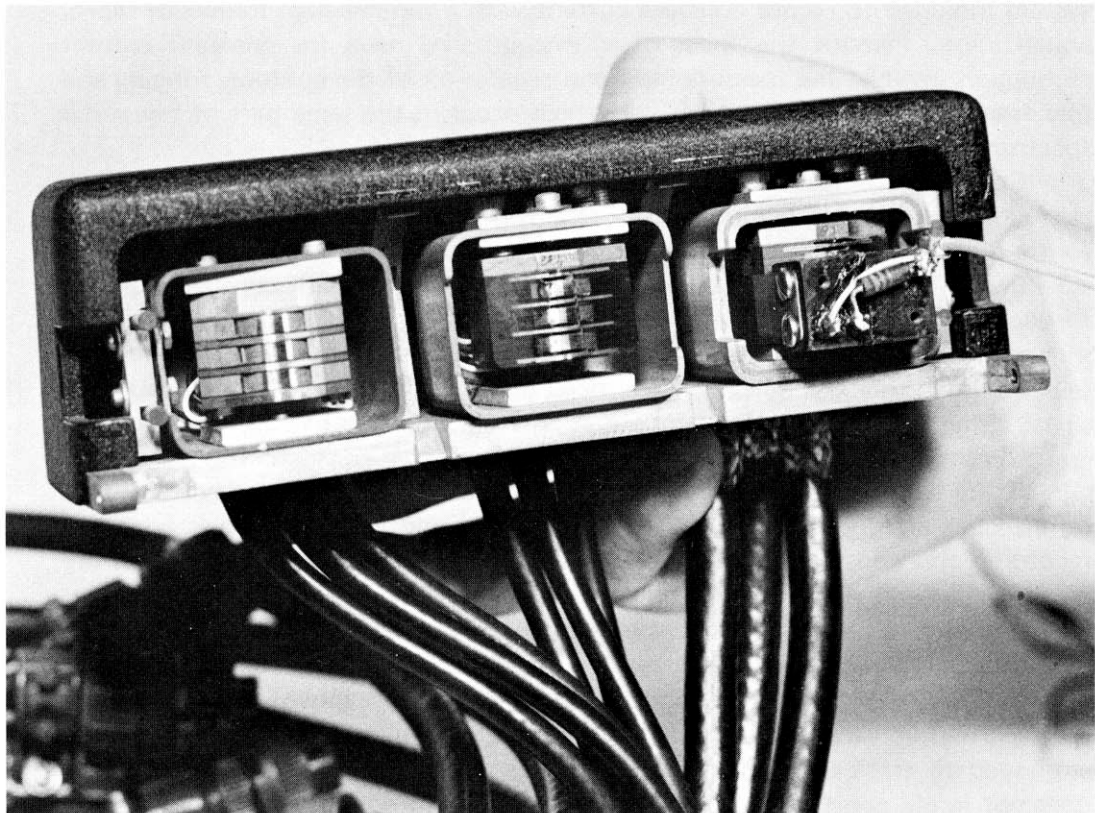

Jig in place on reproduce assembly.

repeatable. The best agreement and repeatability of loop measurement tests as related to response tapes can be achieved by use of a repro. head as close to ideal as the state of the art allows.

In actual use the loop test is simple:

A mid frequency reference tone is supplied to the wire. (400Hz is most often used for the reason that the major American standards committees have shown 400Hz as the zero reference on their charts). The level from the oscillator is adjusted to produce the zero reference on the voltmeter scale (actually about -30 dB as stated above). This meter is connected to the OUTPUT of the repro. amplifier. An additional voltmeter is bridged across the ten ohm resistor in series with the wire. The voltage drop is noted and all subsequent tones are fed to the wire at the same level. In this way we can be sure that the current through the induction wire is the same at all frequencies. Remember, in making any of these measurements that you are seeing the electrical response of the head, plus the cable, plus the amplifier. You can, by sweeping the oscillator, quickly determine the resonance of the system. The cable capacitance will often affect the resonance, so it is well to employ the SAME type of cable from head to amplifier as will be used in practice, when you make loop measurements.

Your attention is called to the introductory remarks heading Section 5. Much confusion occurs when playback amplifier curves are compared to loop response curves. They are NOT the same, but are directly related. How they relate will be found in Section 5.

HOW TO MEASURE CONSTANT CURRENT THROUGH THE RECORD HEAD AND MEASURE HEAD CONTOUR EFFECTS:

It is often convenient to make constant current recordings to evaluate raw tape stock differences, to calibrate low end playback head effects, or to set up a system intended to record constant current with a variable high frequency repro. equalization. Perhaps the most often encountered need for constant current techniques involves the measurement and separation of the contour, fringing and low frequency equalization variables which occur in the same part of the audio spectrum.

Consider the need to determine the head bump (contour effect) of a given reproduce head. Using a good quality record head having the SAME track width as the repro. head to be used, a test tape having a series of tones, or even better, a slow sweep of, for example, 30Hz to 500Hz is recorded with constant current, through the record head coils at each frequency. The resultant tape may now be played back with the head to be measured connected to a FLAT amplifier (electronic voltmeter). Since an ideal head under such conditions will produce a signal rising 6 dB per octave, any variation from this result will indicate effects due to contour design of the playback head.

If the track recorded corresponds to the track width of the playback head, no fringing effect will be noted, and as no low end characteristic is added in recording the constant current tape, these two elements of consideration are removed. Several precautions should be noted: In making such constant current measurements, a record stack of good quality with proper core design should be used to avoid losses at low frequency.

Long wavelength "peaks" and "valleys" will be best shown when spot tones are recorded at very close frequency intervals, or where a pen recorder can be employed to track on frequency paper the reproducer output. Constant current does not imply constant flux level on the tape at all frequencies; however at long wavelengths, constant current through the record head will produce recordings of

METHOD FOR PLOTTING RECORD CURRENT - DURING RECORD MODE

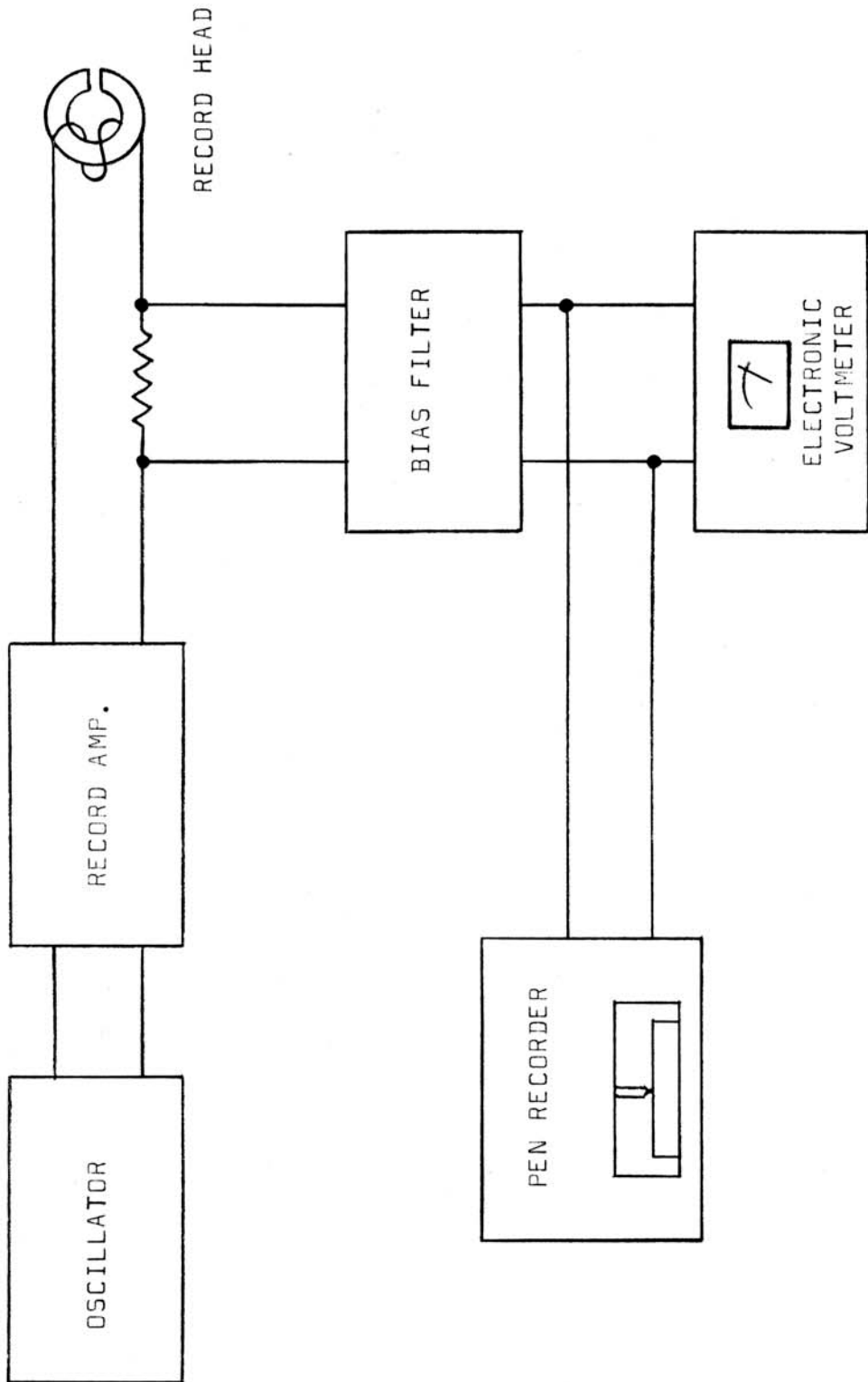

constant flux level within the needs of practicality. Above medium wavelengths, the tape oxide and thickness differences cause differing results depending on the tape used.

To set up for constant current measurement: Determine the current through the record head required to produce a normal level signal at 700Hz or 1000Hz. A 100 ohm resistor can be inserted in one leg to the record head and the voltage drop across the resistor noted. The same voltage drop should be maintained for all tones supplied to the head individually or during a slow sweep either from a pen recorder oscillator unit, or manually with marker or voice identification included. Care must be taken to insure that the bias current signal is not reaching the meter reading across the series resistor during the recording process. On many machines the easiest expedient is to pull out the oscillator tube, or card, and pre measure the current through the head in record mode to insure that it is flat, and then put the tube or card back in and proceed to record the tape "blind". Of course filters, if available, can be used to make possible simultaneous monitoring while recording. Please note that most American made tape recording equipment has some low frequency compensation in the record channel. The "NAB" low end, i.e. 3180 microsec., provides a bass boost of 3 dB at 50Hz with 1 dB at 100Hz. Therefore a true constant current recording will be found to roll off by this amount when played on such a reproducer. This tape would play back flat on a machine without low frequency compensation, as for instance one incorporating European standards.

HOW TO MEASURE TRACK WIDTHS:

It is often necessary to know the exact track width of a recording, such as when measuring a flux level using the "direct method" with a special flux measuring head. As indicated in Section #2, the track width is one of the required items to use the formula.

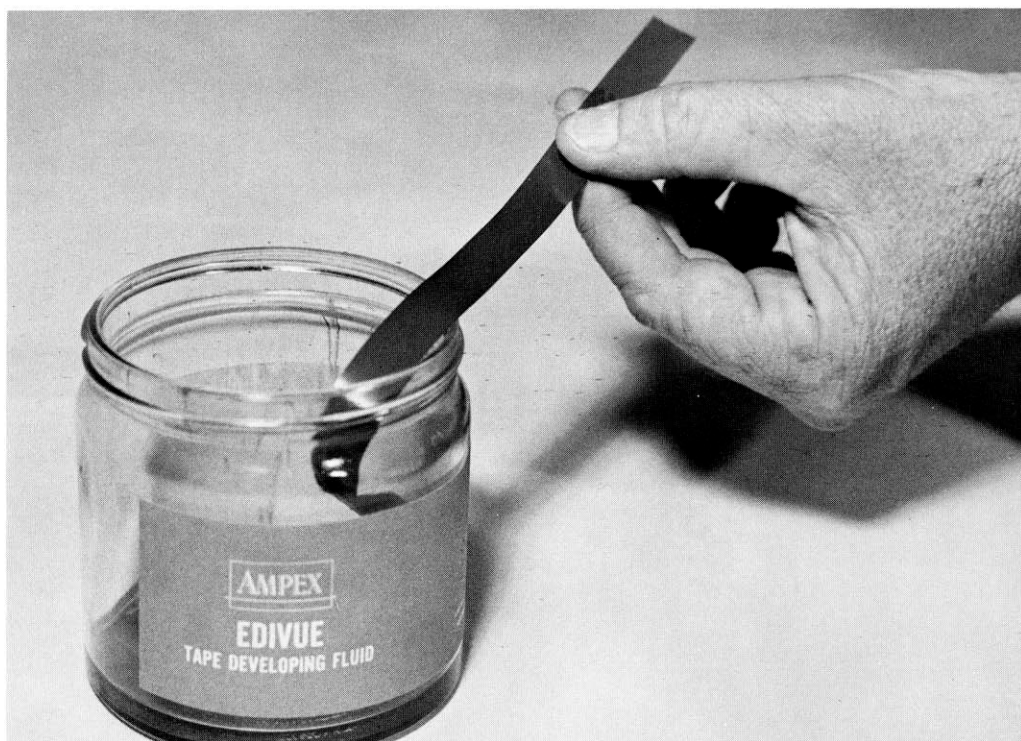

Tape is dipped into indicator fluid.

The vertical location of a record head may be determined by means of edge track width measurement.

The most commonly encountered means of track width measurement involves use of indicator fluids made of carbonyl iron particles in evaporative solution. The resultant pattern is then measured with a tool maker's microscope, optical comparator or other optical device. These instruments are capable of very accurate measurements, PROVIDED THE PATTERN IS ACCURATE AND OF GOOD RESOLUTION. How could the pattern NOT be accurate? The iron particle solution has several drawbacks: (1) Only fairly long wavelengths recorded on tape can be made visible. (2) There is often some "pull back" from the edge of the tape while the material is still in solution, before complete evaporation. Part of this is due often to slight "turn up" of the tape edge. The effect can be shown when making comparisons with indicator fluid, and captive particle viewers. (See illustration) The same edge track may show a narrower pattern on examples treated with indicator fluid, than displayed in the captive particle viewer. Both the viewer and the indicator fluid measurements suffer from a lack of perfect edge definition. With accurate optical readout equipment, (See illustration) it is my opinion that the repeatability of a given track sample can be accomplished within approx. 1 mil.

Another method of measurement, most useful in a laboratory, utilizes a special head assembly having a precise dove tail mechanism coupled to an accurate micrometer stem. The head used for this purpose is specially made up to have only one lamination. Here the recording is "played" to indicate vertical reference points. Such a laboratory set up can provide useful measurements of shorter wavelengths than possible with the normal indicator fluids. Each method has its particular applications and the special head is not as useful in determining track PLACEMENT, where tape edge is the reference from which indicated tracks are referenced.

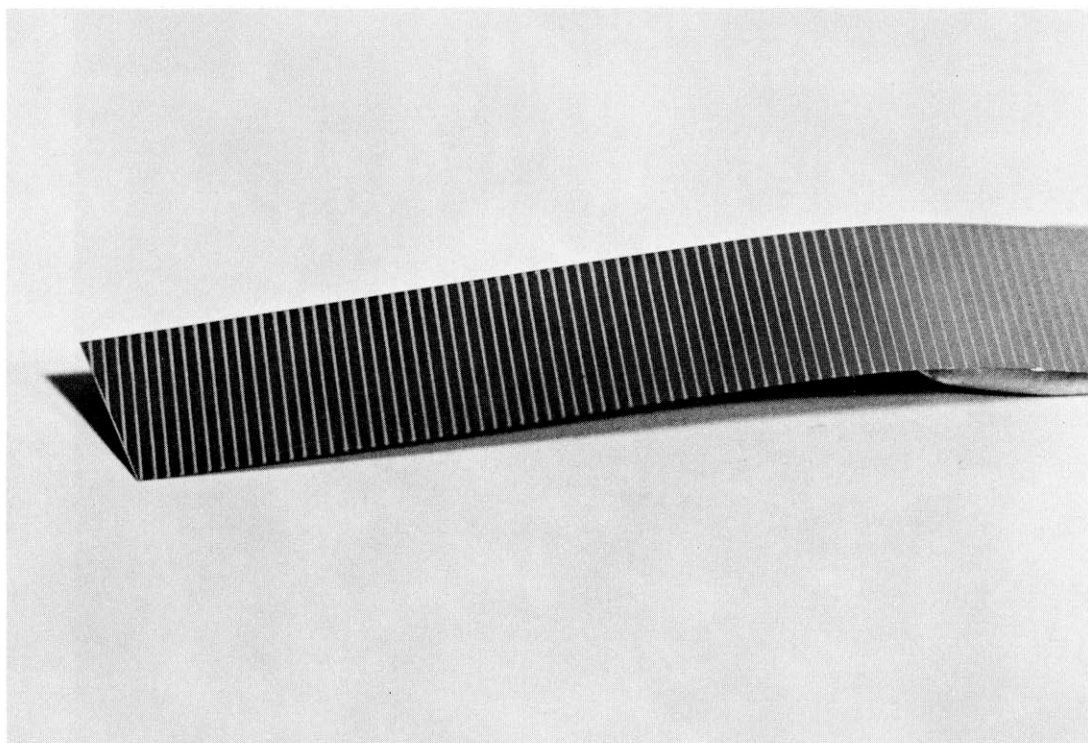

Visible pattern – long wave length recording.



Magnetic pattern as seen with 3M viewer.

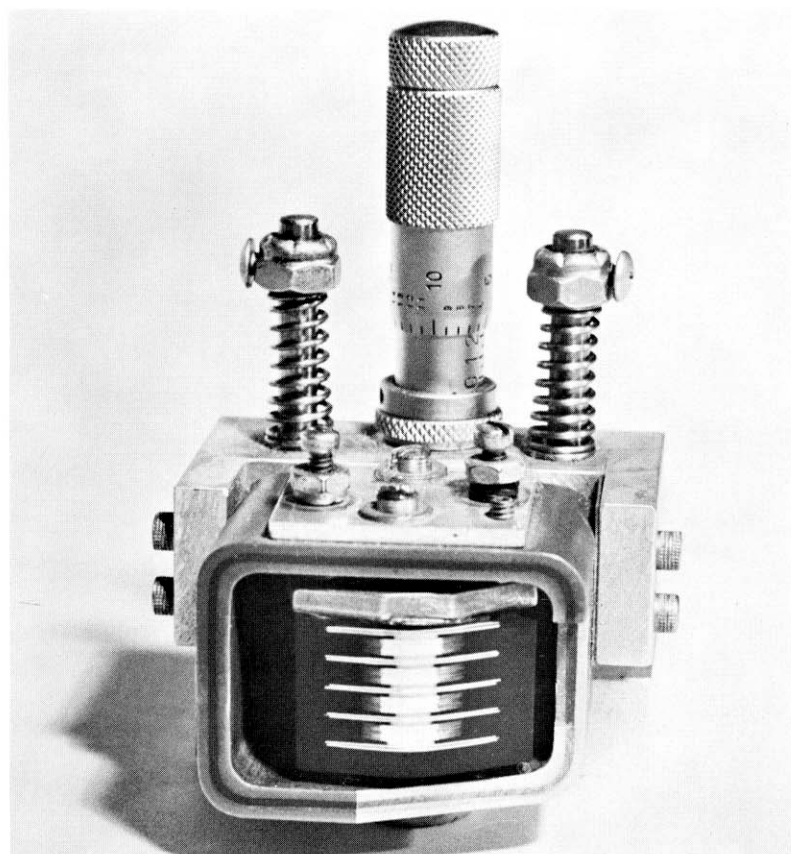

Vertical dovetail assembly.

TYPICAL TRACK DIMENSIONS (Professional Equipment)

Note: Engineering dimension specifications are called out to accommodate the permissible manufacturing tolerances and to avoid "double dimensioning"; thus the foremost specifications published by standardizing committees, which must conform to this practice, do not show all the data of interest in easily digested form. The format presented here, represents nominal patterns for well made heads in accordance with current professional practice.

CASSETTE TAPE FORMATS Tape .144 - .150 in. (3.66 - 3.81mm)

MONO

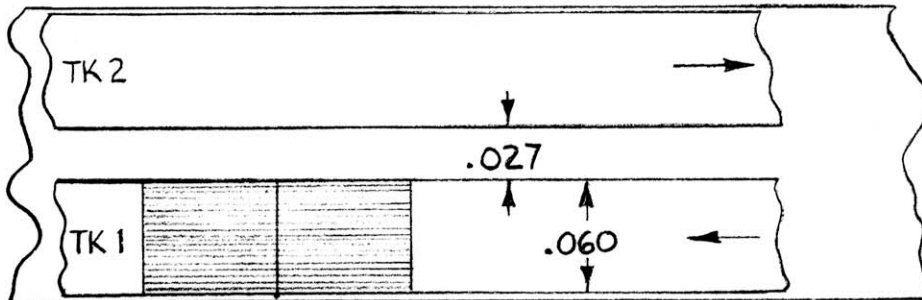

	INCHES	mm
TRACK WIDTH	.060	1.52
GUARD BAND	.027	.69
TRACK CENTER SPACING	.087	2.21

STEREO

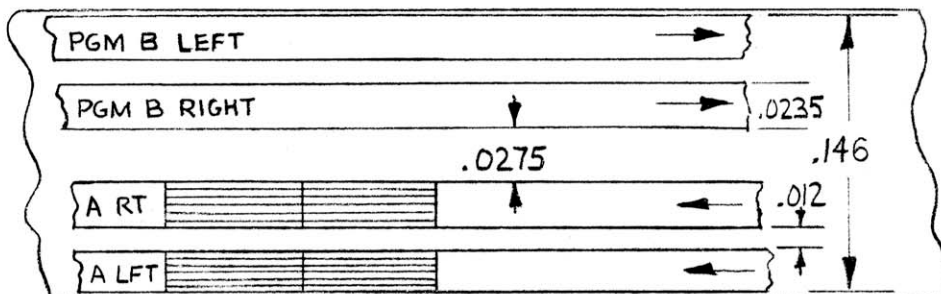

	INCHES	mm
TRACK WIDTH	.0235	.597
GUARD BAND (PAIR)	.012	.30
GUARD BAND (CENTER)	.0275	.699
STEREO PAIR CENTERS	.0355	.902

PROFESSIONAL 1/4" TAPE FORMATS
Tape .244 - .248 in. (6.198 - 6.299 mm)

FULL TRACK

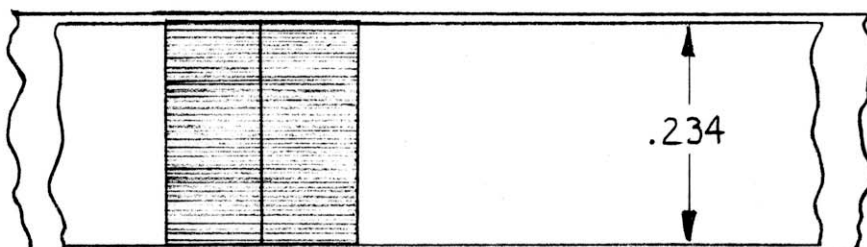

HALF TRACK & 2 TRACK

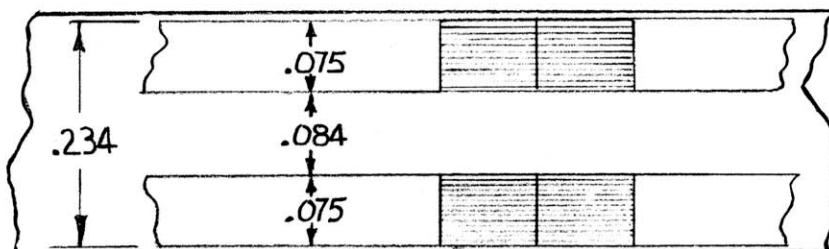

	INCHES	MM
TRACK WIDTH	.075	1.91
GUARD BAND	.084	2.13
TRACK CENTER SPACING	.159	4.04

NARROW TRACK 1/4" TAPE FORMATS
Tape .244 in. (6.198 - 6.299mm)

	INCHES	mm
TRACK WIDTH	.043	1.09
GUARD BAND	.025	.64
STEREO PAIR CENTERS	.136	3.45
ADJACENT TRACK "	.068	1.72

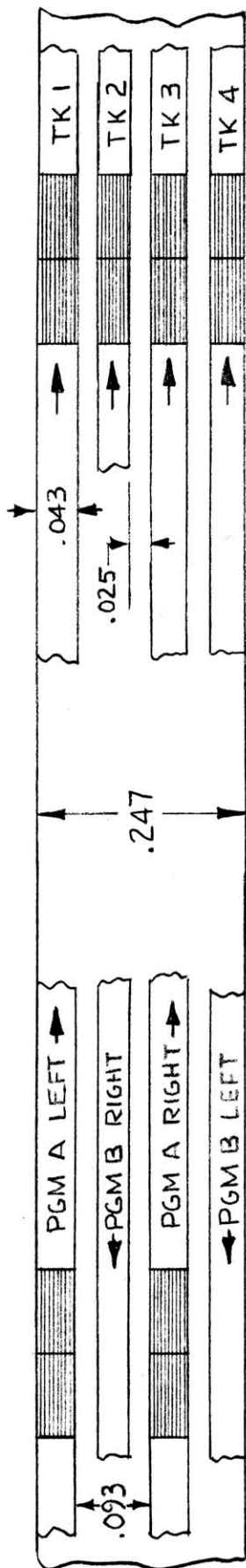

QUARTER TRACK STEREO

4 TRACK

8 TRACK CARTRIDGE

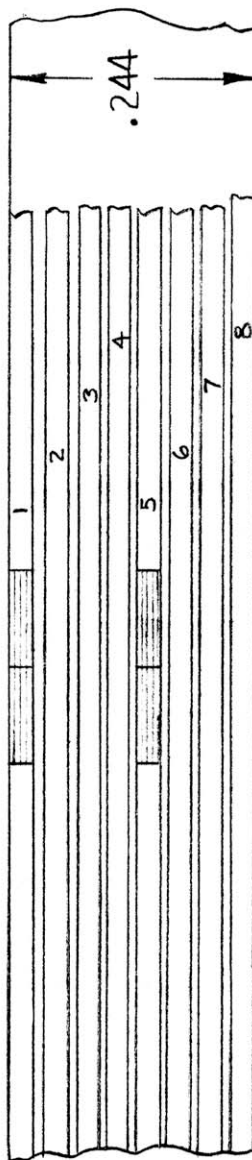

	INCHES	MM
TRACK WIDTH	.022	.56
GUARD BAND	.0097	.246
STEREO PAIR CENTERS	.127	3.22
ADJACENT TRACK "	.0318	.806

EUROPEAN 1/4" 2-TRACK FORMAT

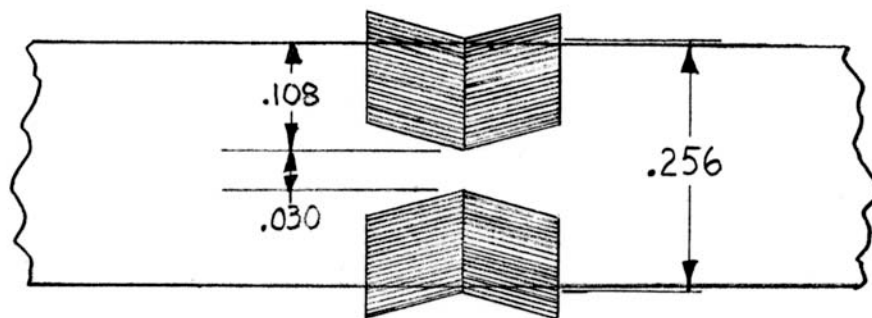

	INCHES	mm
TRACK WIDTH	.108	2.75
GUARD BAND	.030	.75
TRACK CENTER SPACING	.148	3.76

HALF INCH, 4 TRACK FORMAT
 Tape .496 - .500 in. (12.598 - 12.700mm))

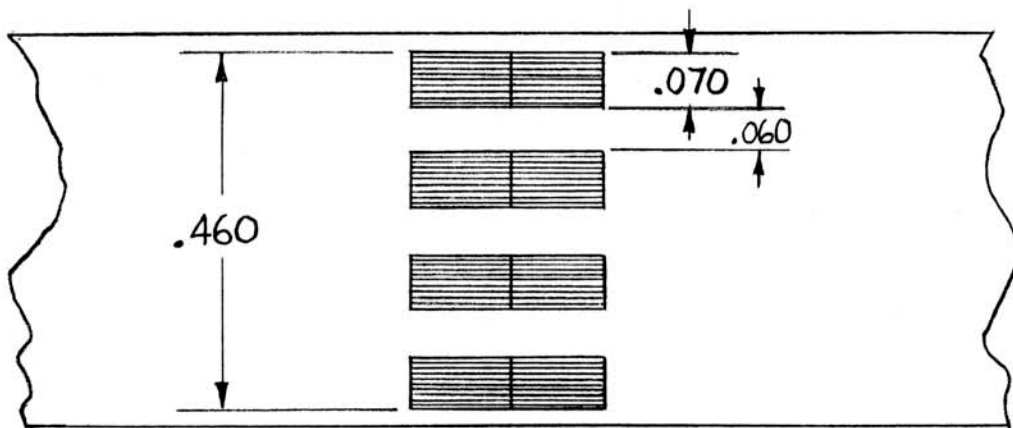

	INCHES	mm
TRACK WIDTH	.070	1.78
GUARD BAND	.060	1.52
ADJACENT TK CENTERS	.130	3.30

ONE INCH, 8 TRACK FORMAT
 Tape .996 - 1.000 in. (25.298 - 25.400mm)

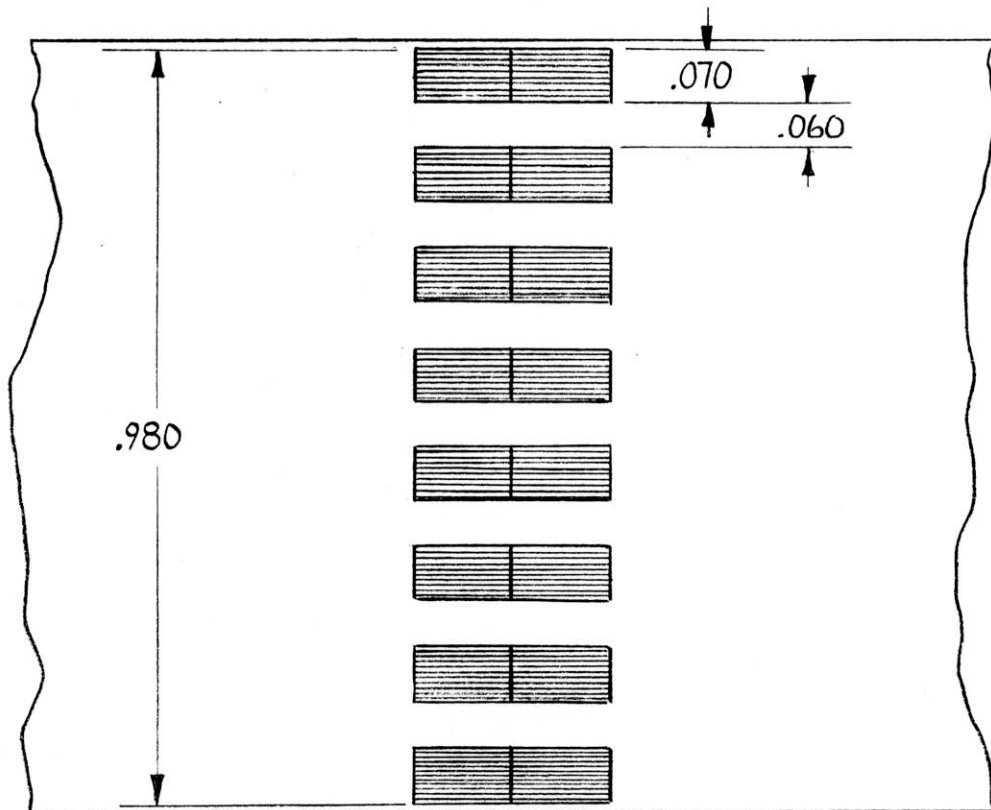

	INCHES	mm
TRACK WIDTH	.070	1.78
GUARD BAND	.060	1.52
ADJACENT TK CENTERS	.130	3.30

TWO INCH TAPE FORMATS
Tape 1.996 - 2.000 in. (50.698 - 50.800mm)

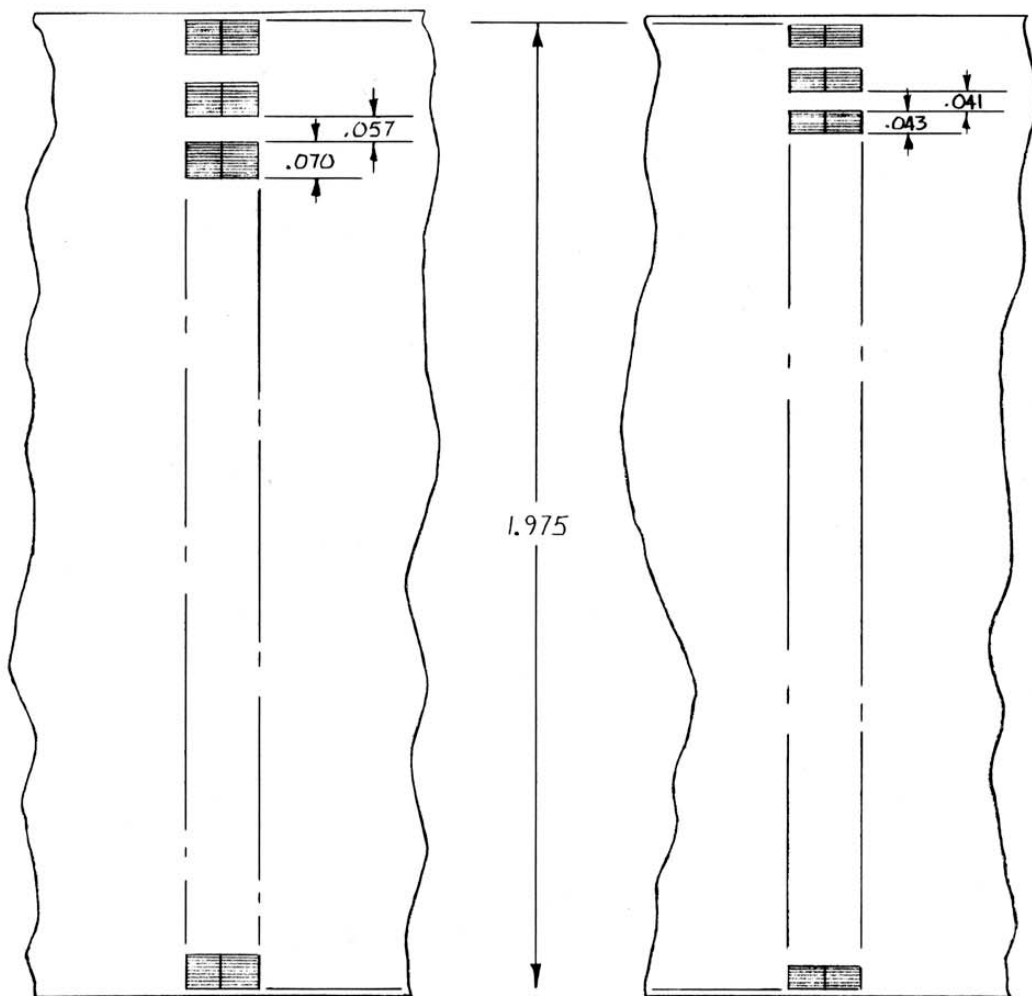

16 TRACK

	INCHES	mm
TRACK WIDTH	.070	1.78
GUARD BAND	.057	1.45
ADJACENT TK CENTERS	.127	3.23

24 TRACK

	INCHES	mm
TRACK WIDTH	.043	1.09
GUARD BAND	.041	1.04
ADJACENT TK CENTERS	.084	2.13

LOSSES TO RECORDED SIGNALS:

The most often asked question the test tape producer must contend with is, how long or how many plays is my reference tape good for? To my knowledge, no one has ever been able to collect enough reliable data to satisfactorily answer in absolute terms loss figures to apply to the many differing conditions, and environments effecting the tape. We do know that there are a number of factors contributing to losses in recorded tapes. These can be listed in two groups:

- (A) Losses resulting from changes occurring in the recorded tape while UNPLAYED, i.e. stored on the shelf. These storage losses can be the result of temperature cycling, magnetic fields and chemical changes in the adhesive binder peculiar to a particular oxide formulation. Some oxides lose flux more readily than others and much has been said about the tendency of cobalt doped oxide to lose short wavelength signals readily.
- (B) Losses resulting after repeated use. Here the various physical changes affecting the tape can be summarized as:

- (1) Bending loss: The flexing of the tape particularly around capstans and guides of small diameter. Capstan idler pressure can contribute to the amount of loss as applied to small diameter capstans. Possibly the losses to some tapes as a result of shock stresses, as can occur with equipment designed to fast rewind after an abrupt start, should be included in the category with bending loss. Just as a permanent magnet can be partially demagnetized by striking with a hammer, a tape may be partially demagnetized by stretching, bending sharply, or winding around a small diameter. Unfortunately, this effect appears to vary with the particular tape oxide and binder. Figures are, in this case, dangerous, however; we have seen losses of $\frac{1}{2}$ dB to recordings of $\frac{1}{2}$ mil wavelength, after ten playings on equipment having a very small diameter capstan. (3.75 ips & 7.5 ips direct drive capstan)

- (2) Oxide abrasion: Actual removal of oxide particles due to abrasion caused by heads, guides, counters or anything contacting the tape's surface.

An interesting sidelight to abrasion is the fact that often with the smoothest head surface the most highly polished tape oxide suffers greatly. The smooth tape and smooth metal surfaces can "stick", causing in addition to "squeal", oxide pull-off, with resultant signal loss.

An excellent method of experiment presented itself a few years ago. A tape had been produced especially to appeal to Audio Visual people, where the student was expected to use a recorded tape on equipment unattended. The tape had a very thin plastic film OVER the oxide. It was reasoned that while there would be considerable spacing loss due to the protective film, the head would remain clean, as no oxide could be removed to contaminate the head. Another advantage was a reduction in head wear, since the film was less abrasive than oxide. There were some disadvantages including the downgraded frequency response caused by the 20 micro-inch film, and resultant spacing-loss and static discharge problems. The tape, however, allowed us to make short wavelength recordings and submit them to normal wear cycles. The results were surprising in that the oxide (similar to 3M 190) showed only about one

fourth the losses after 100 plays as did tape without the protective film. Tension and bending arc were identical in testing both normal and coated tape. The interpretation of the results could easily be misdirected to indicate that all the improvement was due to the fact that the oxide lost not one precious acicular needle, however, we must also recognize that the other variable is the separation itself, which could protect the tape slightly from a magnetized surface. My own opinion is that the erosion factor is an important one in describing losses to magnetic tapes, and next to unwanted magnetic fields, the most neglected.

- (3) Magnetic effects causing losses: Elsewhere in the lab manual, we have described how to check for unwanted magnetic fields. As with all the losses to tape, the shorter the wavelength, the greater the loss. This is especially true in the case of magnetized guides, heads, etc. Here are some figures which you may find interesting, and if you have the equipment handy you can duplicate the conditions. As a matter of fact, it is difficult not to duplicate the conditions (or worse) with most of the equipment available today.

10kHz is recorded at 1 7/8 ips, on 150 mil cassette tape. Tape is passed over a guide showing a 4 Gauss reading taken on a Hall effect magnetometer. The high frequency loss becomes 2 to 2.5 dB when replayed. Four or five passes reduced the signal some 5½ to 6 dB!

A word of caution here, when taking readings on components. Not only is the strength of magnetization important but also the shape of the field. As an example we have seen two guides of different proportions producing the same reading on the Hall effect instrument. The loss caused by one guide was almost twice that of the other.

In the example given above, the wavelength was short, 0.187 mils to be exact. The 2 dB loss would be much less, probably ½ dB if the recording were made at 7.5 ips. In such a case the loss might go unnoticed; however, the accumulative effect would definitely downgrade a test tape or program material after repeated replays. In short, 4, 5, or 10 Gauss fields are NOT all right despite what equipment manufacturers may say. Very probably many manufacturers are not even properly equipped to measure the magnetic contamination of the equipment they design and sell.

Stainless steel is normally used for guides and capstans. Steel designated as #440 is quite hard; however it has poor magnetic properties in that it will magnetize and can be difficult to demagnetize. Once degaussed it may not stay clean. This is the most popular stainless used in commercial audio tape equipment. In wide band instrumentation equipment, the type #303 stainless has been found to be the solution to some of the magnetic problems encountered with short wavelength recording. (125kHz at 7.5 ips, for example) Type #303 is soft, but has good, i.e. antimagnetic properties. With this type of metal, the surface must be hardened by electroplating. A hard chrome finish is applied to the surface, after machining. We point out the above to indicate that you may NOT BE ABLE to demagnetize certain stainless steel components.

SOME PRACTICAL EXAMPLES OF LOSSES SEEN USING VARIOUS OXIDES UNDER CONTROLLED CONDITIONS:

One extensive experiment produced the following results.

3M 111 – 1 mil wavelength	
NUMBER OF SHUTTLES	LOSS IN DB
10	0
25	0
50	0
100	0

3M 111 – ½ mil wavelength	
NUMBER OF SHUTTLES	LOSS IN DB
10	-0.17
25	-0.17
50	-0.72
100	-1.10

3M 206 – 1 mil wavelength	
NUMBER OF SHUTTLES	LOSS IN DB
10	0
25	0
50	-0.26
100	-0.54

3M 206 ½ mil wavelength	
NUMBER OF SHUTTLES	LOSS IN DB
10	0
25	-0.26
50	-0.45
100	-0.72

Maxell A50-10 – 1 mil wavelength	
NUMBER OF SHUTTLES	LOSS IN DB
10	0
25	0
50	0
100	0

Maxell A50-10 – ½ mil wavelength	
NUMBER OF SHUTTLES	LOSS IN DB
10	0
25	0
50	-0.17
100	-0.17

In the above tests made several years ago, the already obsolete 3M 111 tape was used as control reference as it had played such an important part in arriving at a number of the early standards and still remains in vault reference form in many laboratories. It also represented an example of a coarse, non doped, low output oxide.

The results on the previous page were taken on equipment carefully controlled to insure minimum magnetic contamination.

The data are shown to indicate that even under carefully controlled conditions, some short wavelength loss must be expected. We could perhaps conclude here that in the case of 15 ips music masters, 15kHz material (i.e. 1 mil wavelength) should suffer less than 1 dB after 100 plays on well maintained equipment. It also says that your test tape will likely suffer to the same extent.

It should be noted that certain equipment or methods of operation can cause losses of a greater magnitude to recorded material than would be experienced on carefully maintained magnetic tape recorders.

Operations in editing or rewinding which put severe physical strains on the tape should be avoided.

Some equipment providing very fast rewind cycles may accelerate from stop to rewind at a rate which can stretch or snap the tape.

Such sudden tensioning can produce short wave length losses to the recorded tape. Other conditions contributing to problems are:

Editing with counters or other equipment having sharp guide paths or abrasive surfaces.

Proximity of magnetically contaminated items—electric clocks, etc.

In practice, we can minimize "storage losses" through attention to proper, non-magnetic shelving, and by stabilizing temperature and humidity of the environment. Too low an humidity should be avoided as it can accelerate print-through problems and may produce some static problems. (60 to 70 degrees F, and 40 to 60% humidity, has proven satisfactory)

The main concern should be directed to the reproduction equipment. One should avoid "pin sized" capstans, sharp tape path bends, and particularly transports and heads that magnetize easily.

HOW TO MEASURE DISTORTION:

The most useful instrument for measuring distortion in tape equipment is the wave analyzer. Only with such an instrument can the various contributors to even and odd harmonics be separated. For example, amplifier problems and MAGNETIZED HEADS will contribute to the second harmonic, while the proper record bias current relates to the third harmonic for a given tape. The total harmonic distortion meters such as seen in most broadcast installations show everything excluding the fundamental, and therefore, all harmonics as well as noise and flutter show up in the total. As the broadcast market is a big one in the audio magnetic field, such equipment—particularly the cartridge machine—is often specified as to total harmonic content. 1.5% is an often quoted figure. Head magnetization, noise and flutter may produce the remaining figure as read out on a total analyzer. Actual distortion content for a quality broadcast machine using average lubricated tape would be approximately 0.7% third harmonic and 0.2% to 0.4% second harmonic. The total harmonic analyzer will combine these figures

along with noise and flutter to produce a higher reading than the true distortion on the tape. The above assumes a low distortion oscillator as a test signal source. We should caution also that use of a total harmonic analyzer is difficult with any system having flutter components, which will cause irregular meter readings. A satisfactory procedure to follow in setting and maintaining tape equipment as related to distortion is as follows:

- (1) After calibrating the reproduce channel to the desired reference level, record a 15 mil wavelength signal (1000Hz at 15 ips, or 700Hz is satisfactory at 15 ips and 7.5 ips) on the TAPE TO BE USED. Adjust bias current to produce highest output and re-adjust record level control to produce your ZERO reference.
- (2) Calibrate wave analyzer and measure the distortion of the oscillator being used. (Look at second, third, etc harmonics)
- (3) Calibrate wave analyzer to tape machine output with output switch in tape position and take third harmonic reading. (For example, 2100Hz for a 700Hz signal) Modern tape oxides at normal audio speeds and operating levels range generally in the region of .3% to .8% third harmonic for levels of 185 nWb/m to 261 nWb/m.
- (4) Shift wave analyzer to read second harmonic, i.e. 1400Hz as above and IF the record amplifier has noise balance control, adjust for minimum second harmonic. (The range of noise balance controls on some equipment can cause changes ranging from 1% or 1½% second harmonic to a null approximating the oscillator content). IF the second harmonic remains anything but very low, the head stack should be demagnetized, also one should re-adjust noise balance control for minimum second harmonic and the reading repeated. PM magnetic fields in the head stack cause second harmonic. THE VALUE OF THE ABOVE PROCEDURE CAN HARDLY BE OVER EMPHASIZED, FOR THE SECOND HARMONIC IN MANY MACHINES BEING USED FOR MASTERING IS A MAJOR FACTOR IN INCONSISTENT QUALITY. We have seen extreme cases of magnetized heads causing 3% and 4% second, and that can, of course, be heard in the program.

If a sensitive magnetometer is at hand, this would be a good time to scan the head stacks for PM "contamination" as related to the second harmonic readings taken. Also it should be pointed out that some head demagnetizers can, depending on use, i.e. how fast the tip is withdrawn, etc. produce a field in a head stack. Switching transients and other factors can also be a problem in this respect. One of the most interesting conditions came to the author's attention some years ago when we noticed that a certain big name professional machine used primarily in broadcast service, built up a strong permanent magnetic field in its playback stack in a short time after the head had been carefully degaussed and harmonic measurements taken. Invariably the playback stack "took on" about 4 or 5 gauss, with the result being a high distortion reading. The nature of the head laminations and the head coil being directly fed with DC in the transistor circuit caused the problem and, for all I know, still does in this still available "professional" machine.

HOW TO CHECK FOR MAGNETIZED COMPONENTS AND OTHER ELECTRICAL FIELDS CAUSING UNWANTED ERASURE AND NOISE:

On page 23 we indicated the relationship of second harmonic distortion to PM fields in a reproduce head. The same PM contamination of the head can cause severe short wavelength erasure to recorded tapes. The slower the tape speed employed, the greater the top end loss to be expected from magnetized components. In the last section of this manual, several types of simple and elaborate magnetometers are illustrated. The simple meters are inexpensive and are highly recommended, however, they only indicate PM FIELDS. AC fields often are the culprit. One professional machine actually showed an AC field caused by a misplaced solenoid of 34 GAUSS with the machine in a rewind mode and the tape lifters actuated. The field was concentrated at the supply reel side of the transport at the flutter idler guide. Many top selling machines have been designed and sold without any consideration by the engineering departments as to AC magnetic field contamination. A poorly filtered DC supply may carry enough AC ripple to do a lot of damage to a tape passing near a solenoid or relay coil. The simple magnetometer may only show a field of a few gauss under the same conditions. The minimum equipment needed to look for catastrophic conditions due to magnetic fields would be one of the simple magnetometers such as the ANNIS 5-0-5 Gauss model and one of the magnetic viewers as indicated for track width measurement in Section C. Ideally a "Hall effect" type of magnetometer with a variety of crystal probes can be used to indicate very small magnetic fields, AC as well as DC. Such an instrument is more expensive as it requires its own set of electronics, but has the added advantage of being able to calibrate for the earth's field. In looking for magnetic contamination it must be remembered that there is about 0.5 gauss due to the earth's own field, and on measurement equipment of the most sensitive variety, this field will show up in the reading, depending on "compass" orientation of the meter or probe during use. To check for magnetized heads: measure second harmonic of recording; if high, measure field at head with magnetometer. If questionable, degauss and remeasure. Similarly examine the guides, the capstan and any metallic surface to contact the tape. Even "Stainless" materials called non magnetic are capable of retaining some field and are, therefore, suspect. If a magnetometer is not available but a magnetic "Viewer" is, use this to observe any darkening of the magnetic particle suspension as the viewer is brought *as close to the object as possible without touching it*. These tools are responsive to pressure of the diaphragm as well as fields so care must be taken not to touch the indicator to the object.

If none of the above equipment is available, a rough test can be made as follows: Record a fairly short wavelength, say, 15kHz at 7.5 ips. Observe playback level and reproduce ten times, observing any change. Losses can be result of demagnetization by the transport components. Any pops or noise noticed as a result of stops and starts would lend suspicion.

The most often asked question concerning magnetized parts and resultant losses is "HOW MUCH IS TOO MUCH"? To provide a given amount of high frequency loss for a given field is difficult for several reasons. The SHAPE of the field bears on the result as well as the measured strength as shown on a magnetometer. The nature of the tape oxide is also of importance, as is the spacing between tape and component. The particular machine mentioned earlier with the highly magnetized guide caused a deterioration of about 3.5 dB to a 15kHz signal recorded at 7.5 ips after twenty plays. The above experiment was made on 206 tape and the same experiment repeated in another laboratory on transports of a different design showing almost no stray AC or PM fields in the

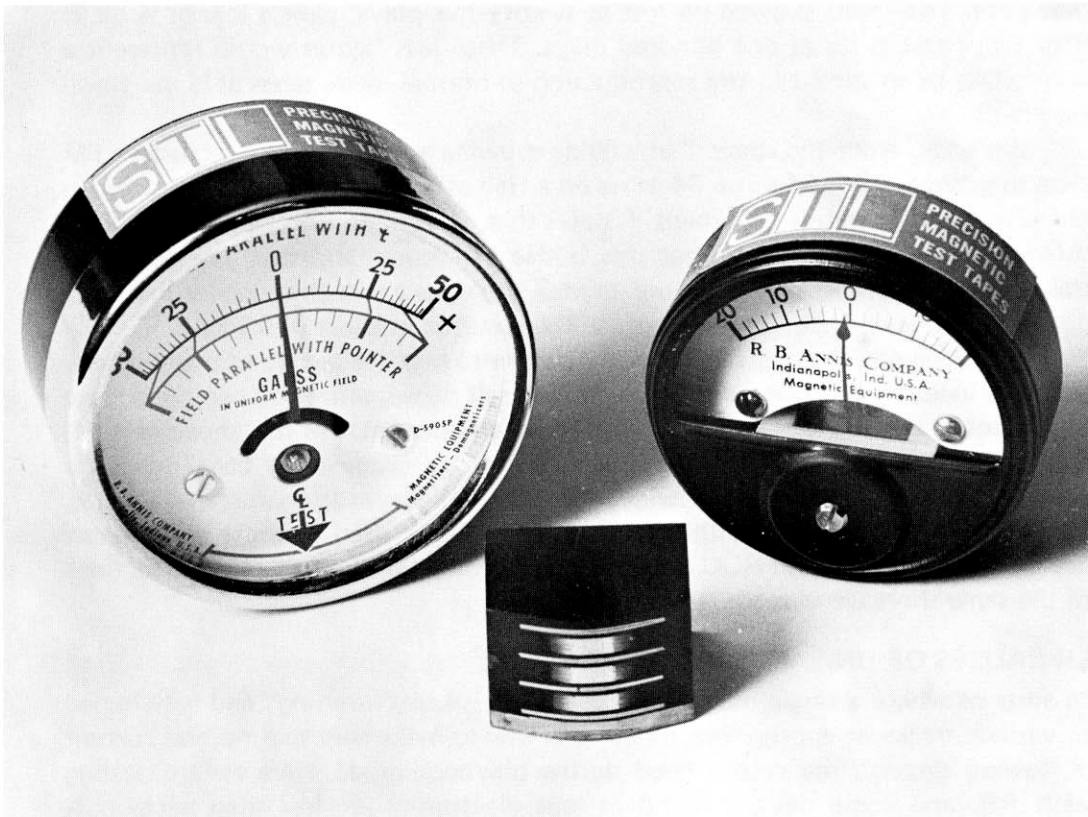

Inexpensive self contained Gaussmeters.



Hall effect Gaussmeter – Note: Head shows almost 5 Gauss field.

tape path. The result showed no loss at twenty-five plays, with a loss of $\frac{1}{4}$ dB at fifty plays and $\frac{1}{2}$ dB at one hundred plays. These loss figures would represent a "norm" to be expected in the reproduction of normal oxide tapes at $\frac{1}{2}$ mil wavelength.

We know from the above that a guide showing about 10 or 11 gauss on a PM type magnetometer and some 34 gauss on a Hall effect meter was TOO much. An old Library of Congress document*¹ states that maximum flux density permitted should be 10 gauss. We feel that this is also too much, and that any direct exposure of a recorded tape to more than 3 or 4 gauss will show up as loss. Ten passes over a head stack showing 4 gauss PM, resulted in a loss of 0.75 dB.

We recognize that other factors contribute to high frequency loss as well and all these including bending loss, abrasion, and self demagnetization can contribute to the total, thereby obscuring the individual components. In the above remarks concerning degree of loss due to magnetization, allowance has been made for variations in tape tension, arc of wind, capstan to idler pressure, capstan diameter, etc. The SAME transport without adjustment can be used to show the changes occurring WITH and WITHOUT a magnetized component when playing sections of the same short wavelength recording.

OTHER CAUSES OF UNWANTED ERASURE:

In systems where a single master bias oscillator is kept "running" and is switched to various tracks at appropriate times, it is well to make sure that no bias current is flowing through the record head during playback mode. Here we are dealing with RF, and some designs found in tape electronics are less than perfect. A "buffer card" may be shorted out during playback mode; however, since bias is "RF", the "loop" in the wiring may couple to the circuit to allow a small amount of bias to leak through during playback. A multiple track instrument recently came to our attention after it mysteriously dropped the level on the high frequency section of a one inch test tape only on two channels. A scope showed about 3.5 to 4 volts of bias on the two record head tracks during *playback*. The program track being added-to, also suffered audibly with repeated playbacks. Here we can say that for this machine, 4 volts of bias through the record coils was too much during playback!

One other test found useful should be mentioned: With the scope across the record head, and the machine in playback mode, the start-stop-rewind modes should be actuated and any record coil signal observed. Only the poorest designed machines will suffer in this respect, however; THEY ARE OUT THERE!

HOW TO CHECK FOR HEAD RESONANCE (and cable and core loss effects)

With the same loop setup as described in Section 7 A, an oscillator is slowly swept as the output is read on meter or scope. As the system passes through resonance, the response will cease to rise and will fall rapidly. As we recognize that the lower the inductance of the head, the higher will be its resonant point, we can choose the appropriate head for the job. It is usually good practice to choose the head having a resonance well outside the frequency band of interest. For example, if we desire only 15kHz response, then a head having a resonance of only 17kHz could be used, and, as a matter of fact, the beginning rise at 15kHz could be part of the playback eq. It is more common in audio machines nowadays to choose a head with a resonance of 22kHz or more. For standards work most prefer a head well outside the audio band, say 27kHz or more. At frequencies at the upper end

*1. Preservation and Storage of Sound Recordings, A. G. Pickett, M. M. Lemcoe 1959.

of the audio band the head may suffer from core losses caused by shorted laminations, improper insulation of cores, or the lamination material itself. We mention this because in the case of duplicators, for example, where very high frequencies are encountered, a situation can occur where the inductance is chosen to be quite low to provide high resonance, but the core losses cause the head to roll off at a much lower frequency than its expected resonance. Another caution: A head is commonly measured on an inductance bridge, to determine inductance and "Q" by means of clip leads attached to the head's terminals. The cable capacitance is, therefore, not seen. THE CAPACITANCE OF THE REPRO. HEAD CABLE IS OFTEN THE CULPRIT IN CAUSING LOWER THAN DESIRED RESONANCE. Changing the cable to a lower capacitance type, if available, or shortening it, may be required. In head production or checking work, the most convenient method of charting head resonance is through the use of an oscillator/pen recorder unit supplying signal to the head WITH ITS NORMAL CABLE, and into a 6 dB/oct integrating amplifier of the same input impedance. The result then reflects the combined effects of head resonance with cable, and core loss effects.

CHECKING FOR UNGROUNDED HEADS

Static noise may be added to valuable program tapes, if any of the head cores are not properly grounded to the frame of the head stack. While stacked head laminations must be insulated from one another as well as from the side pieces of the head to eliminate unwanted core losses, the stack should be grounded to the frame at ONE point to prevent static build up.

The effect is particularly troublesome with high speed equipment such as in



Checking for resistance between core and frame.

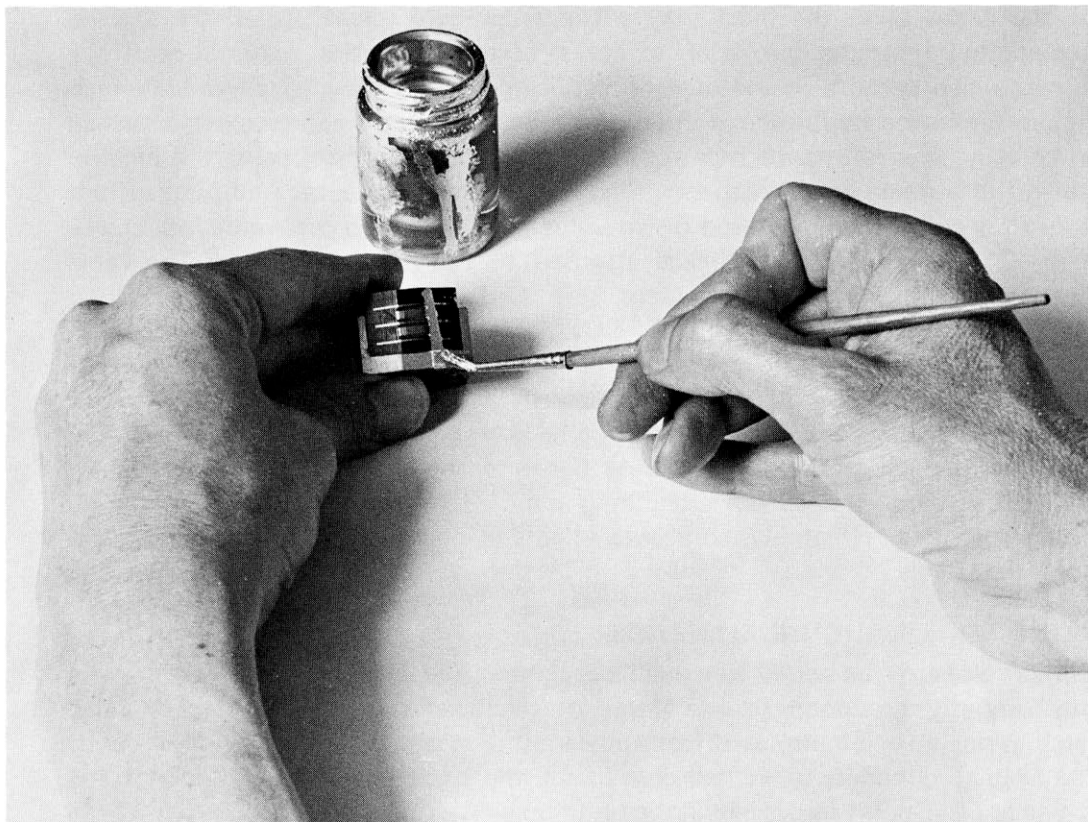

"Painting" a ground with conductive silver paint.

duplication. Plastic or paper leader tape traveling across an ungrounded stack can cause discharges producing pops and thereby render the master useless. The resistance from core to head frame must be practically nil to be satisfactory. The accompanying illustration shows a two track head having about 6 ohms from core to ground. This is an actual example and is not faked. This head caused noise and was removed from service for that reason.

Silver conducting paint is often used as shown to ground the core to frame. During initial manufacture, heads are usually grounded at the rear, rather than at the front; however "repairs" can be carefully made on the front as shown in the picture. The stripe must be applied to one side of the gap, far enough from the tape wear pattern, not to cause spacing loss.

Remember to wait a sufficiently long period of time after striping the head for the solvents to evaporate, rechecking resistance of core to ground. Depending on the conductive paint used, 10 to 20 minutes should be adequate.

An old technique which we do NOT recommend was to score the core down one side with a screwdriver and ground the last lamination to the frame. The silver paint is the better way and the only excuse for the violent approach might be in a situation where desperation dictates such action.

In checking core grounding, take care not to touch the meter prods to the gap itself or area of wear-pattern, always aim for one side.

WEAR PATTERNS:

It is very important that the heads are set at the outset, i.e. before any wear pattern develops, for proper zenith, and meridian as well as azimuth. A new,

unworn head may be set to operate within specs even though it tilts forward, or back, or is turned too much to one side or the other. The problems arising after a poor wear pattern develops, cannot then be corrected, for any adjustment will cause instability of the tape as it tries to climb a trapezoidal wear pattern or fight a groove in a head which is acting as a guide.

A properly adjusted head will have an even pattern with the gap near the middle of a rectangularly worn "flat". Illustration "A" shows an average fair wear pattern. Illustration "B" shows the head disassembled to indicate a rather even core depth after considerable wear.

Not only is the proper wear pattern desirable as contributing to stability of tape travel during usage, but even core wear in record stacks maintains the best flux distribution across the track width.

The following illustrations show wear patterns resulting from improper zenith adjustment. The resulting trapezoidal pattern, in the case of the full track head was caused by the head being tilted backward in the assembly. The lower part of the stack wore more than the top area, and the head height was wrong. Illustration "D" is a highly magnified view of a half track head as found in a duplicator. The trapezoidal pattern here was not the result of improper zenith adjustment but rather to the fact that the head is constructed of normal mu metal core with a brass "shoe" to support the tape. The brass, being softer, wore sooner, thus producing the wear pattern.

A highly recommended method of initially setting up head assemblies is as follows: Using either a soft wax pencil or felt tip pen, color the front of the head with a light even coat. Then thread the tape and run a hundred feet or so in play mode, to produce a "wear" pattern. In this way you will be able to predict the

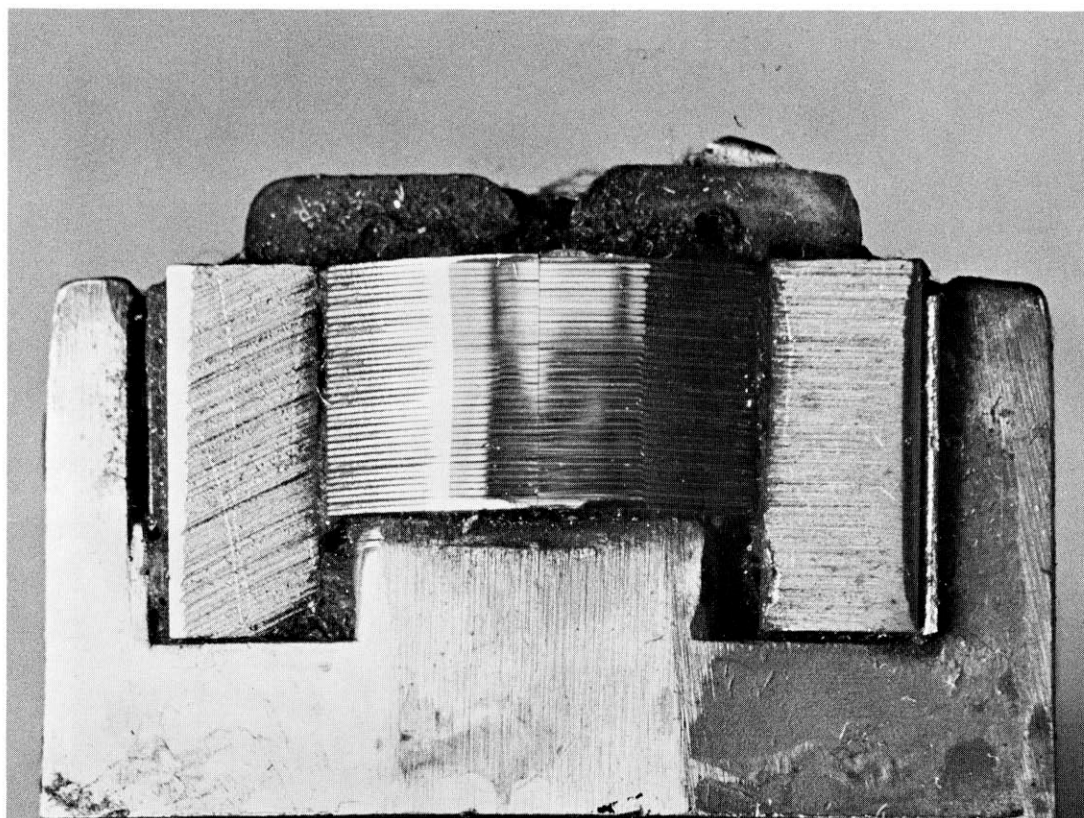

Figure A – Average wear pattern.

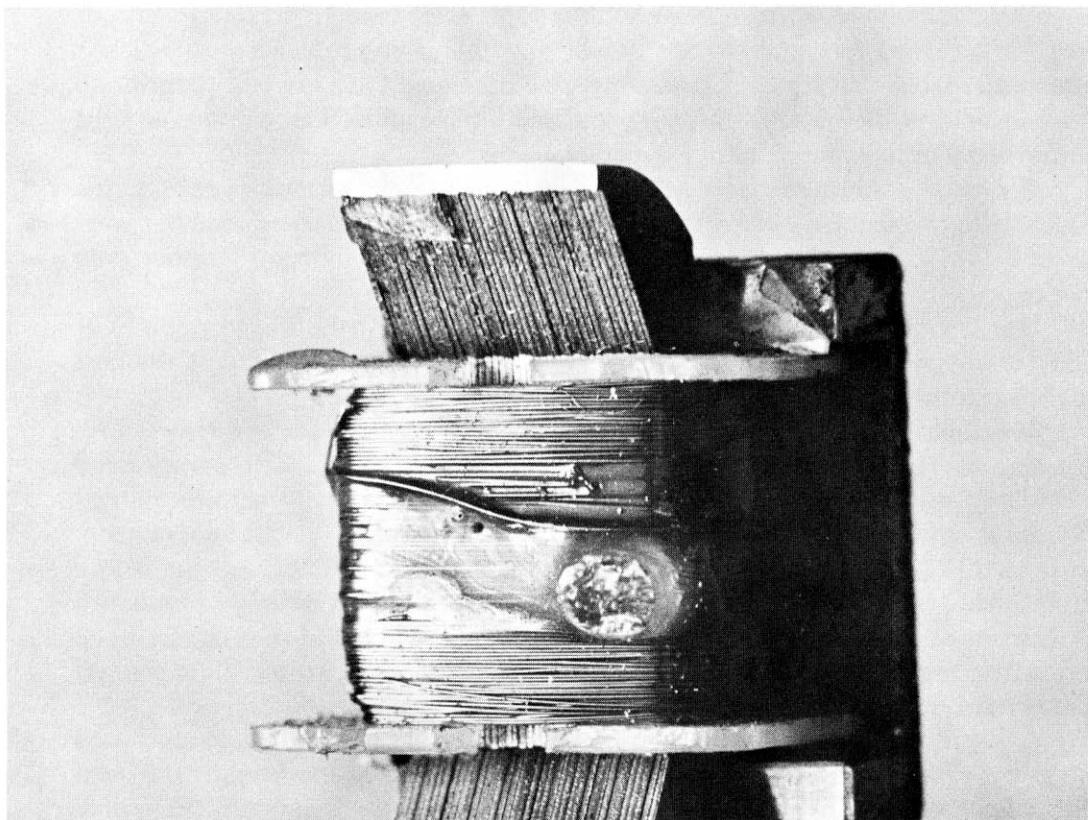

Figure B – Even core depth – head disassembled.

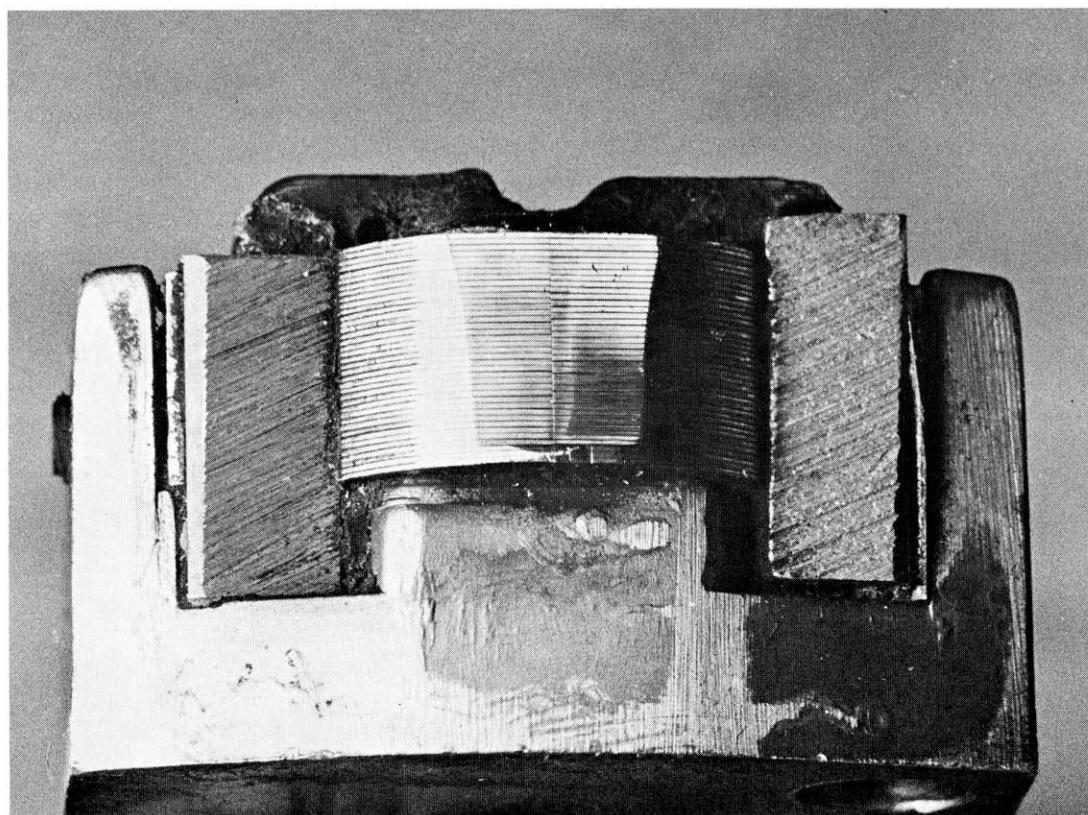

Figure C – Trapezoidal wear pattern.

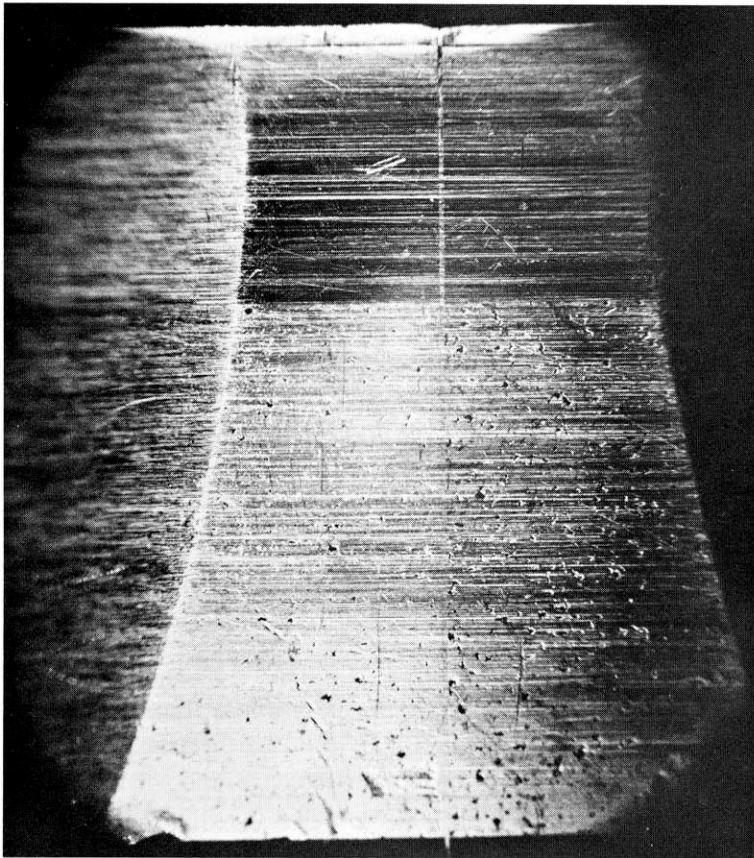

Figure D –
Highly enlarged $\frac{1}{2}$ track
head with trapezoidal pattern.

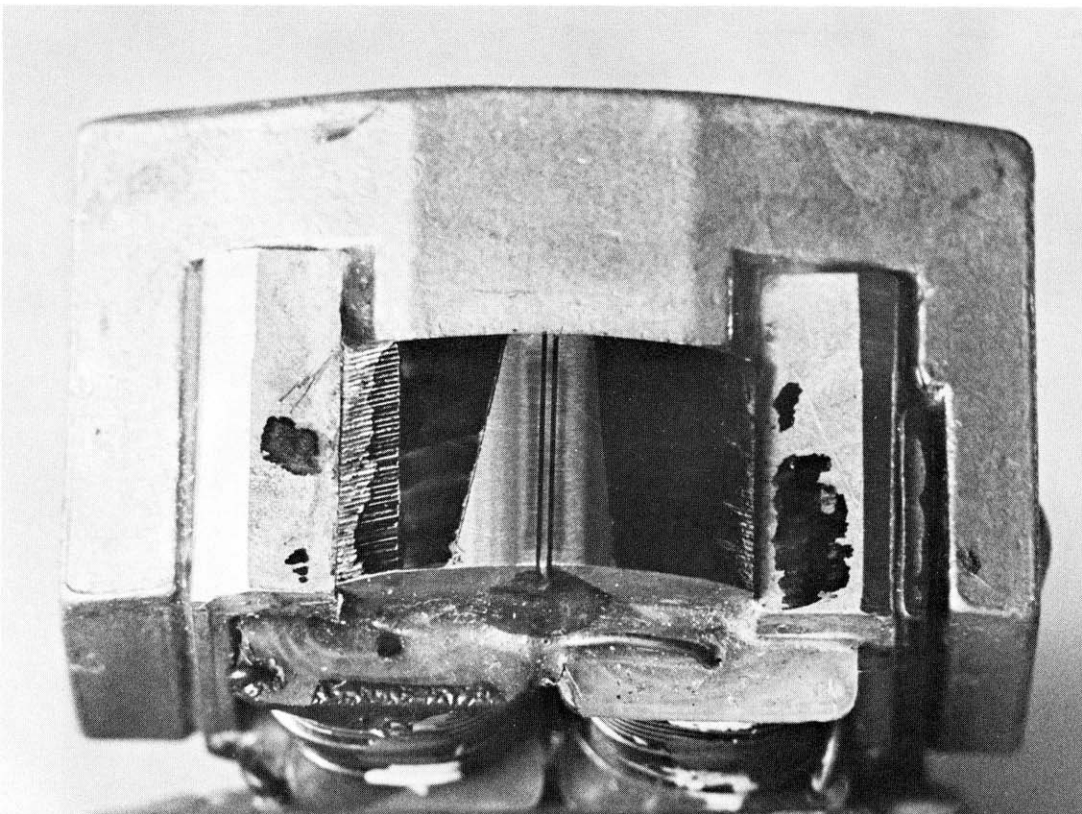

Figure E – Pattern after felt tip pen ink is worn away indicates improper "Zenith."

type of pattern to expect before an actual wear pattern occurs. As in figure "E" an improper zenith will be apparent. Repeating the experiment after adjustment reveals in fig "F" a meridian problem, that is the gap is to one side of the pattern, and there is still some zenith error. We have used an erase head with large gap in this example, so that the gap may be easily seen in the picture.

A commonly encountered mistake results from the assumption that only the record and reproduce heads are of concern as to meridian and zenith, since "anyone knows that erase heads work all right however they are adjusted." The wear pattern on the erase head as well as any other component in the tape path contributes to the continued stability of the tracking of the tape, and therefore erase heads should also be set up properly as to attitude.

Guides, particularly glass guides, often groove in more than one area. These multiple grooves can come from effects of rewinding, with partial tape lifting, fast forwarding after the head wear patterns cause steering dependent on speed, or from the use of various "white box" tapes having differing slitting dimensions. (One reason white box tape may be the worst "bargain" a recorder user may ever encounter.) Once a tape guide develops multiple wear grooves it is a matter of Russian Roulette as to which groove the tape will follow on which pass.

Capstan and idler wear patterns see Fig. "H" also contribute to tape instability and skew. A machine having wear patterns similar to those shown cannot be realigned for optimum performance. Where for example critical phase control, as in two track stereo broadcasting is called for, there is no alternative but to replace or have relapped the head stacks along with worn guides or idlers. Any attempt to skimp here is futile. The aforementioned wear patterns are those seen on standard tape recorder type head bridges. Motion picture projectors and

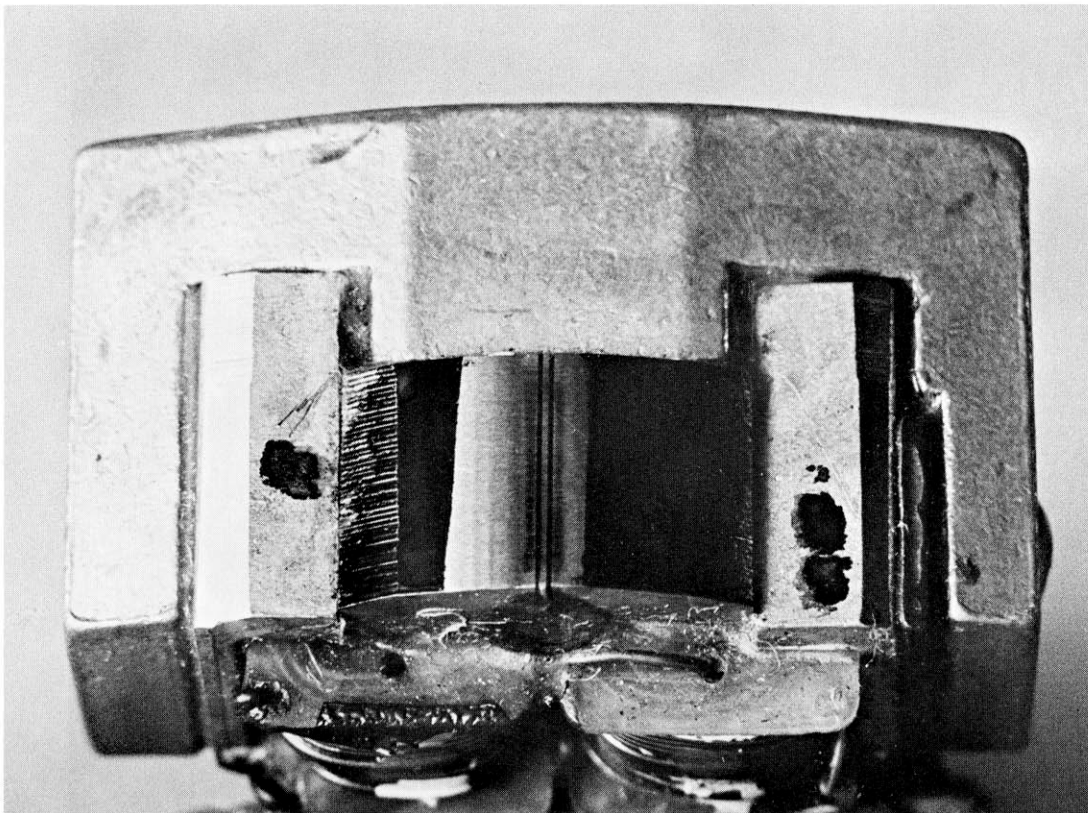
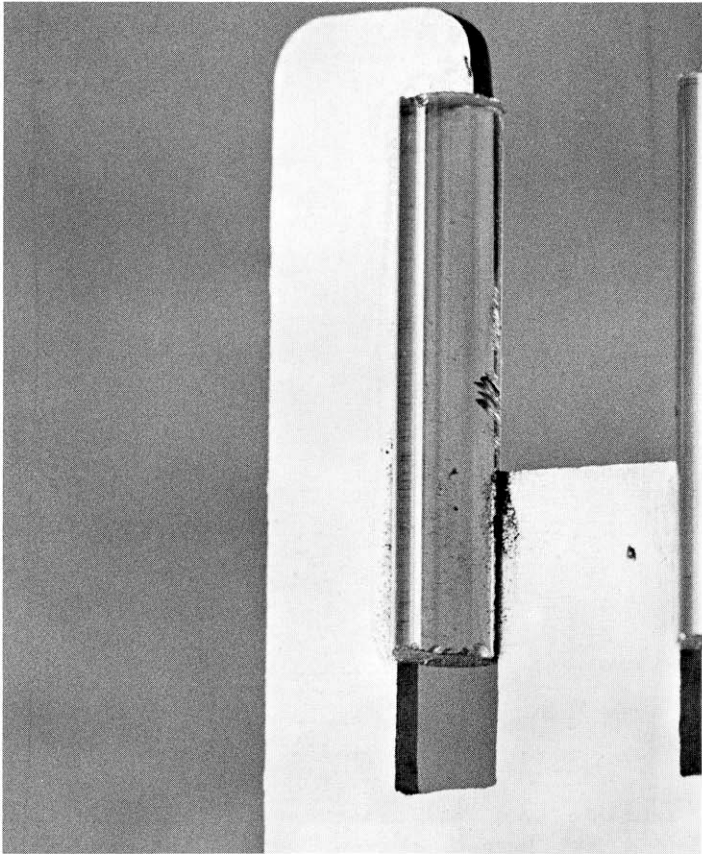

Figure F – Improper "Meridian."



*Figure G –
Glass guide with multiple grooving.*



Figure H – Grooved capstan idler can cause steering with resulting skew

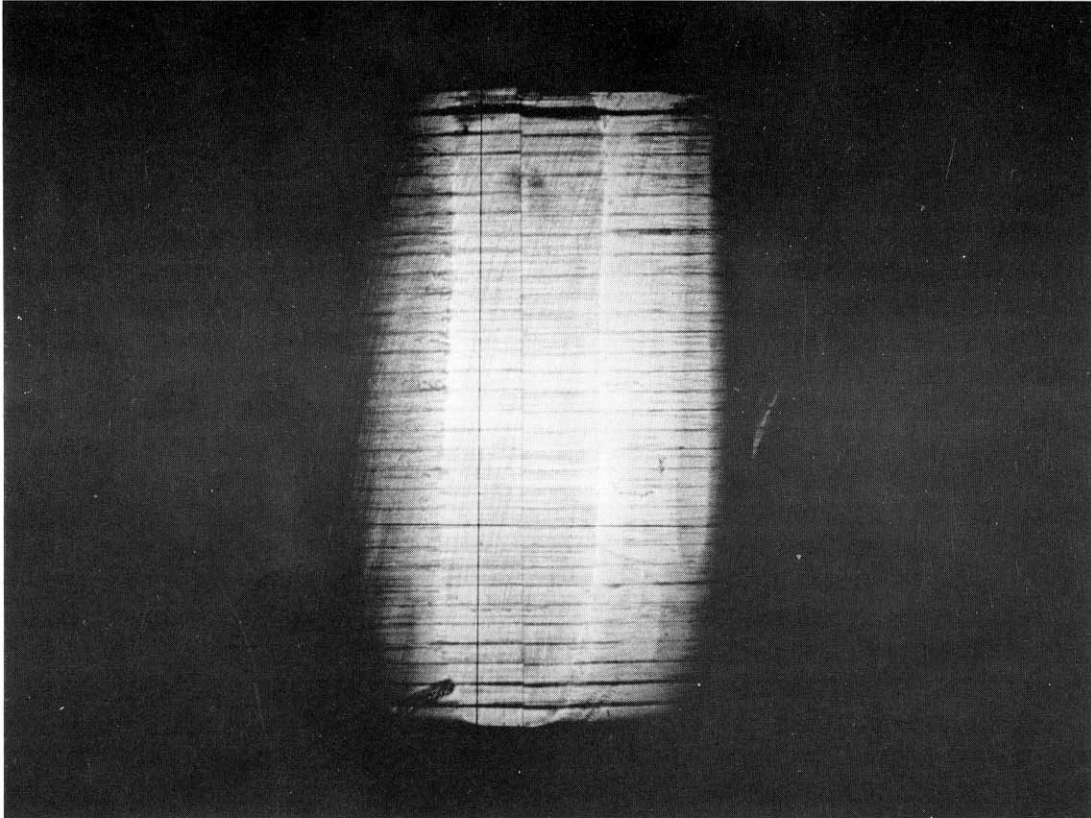

Figure I – Drumhead wear pattern.

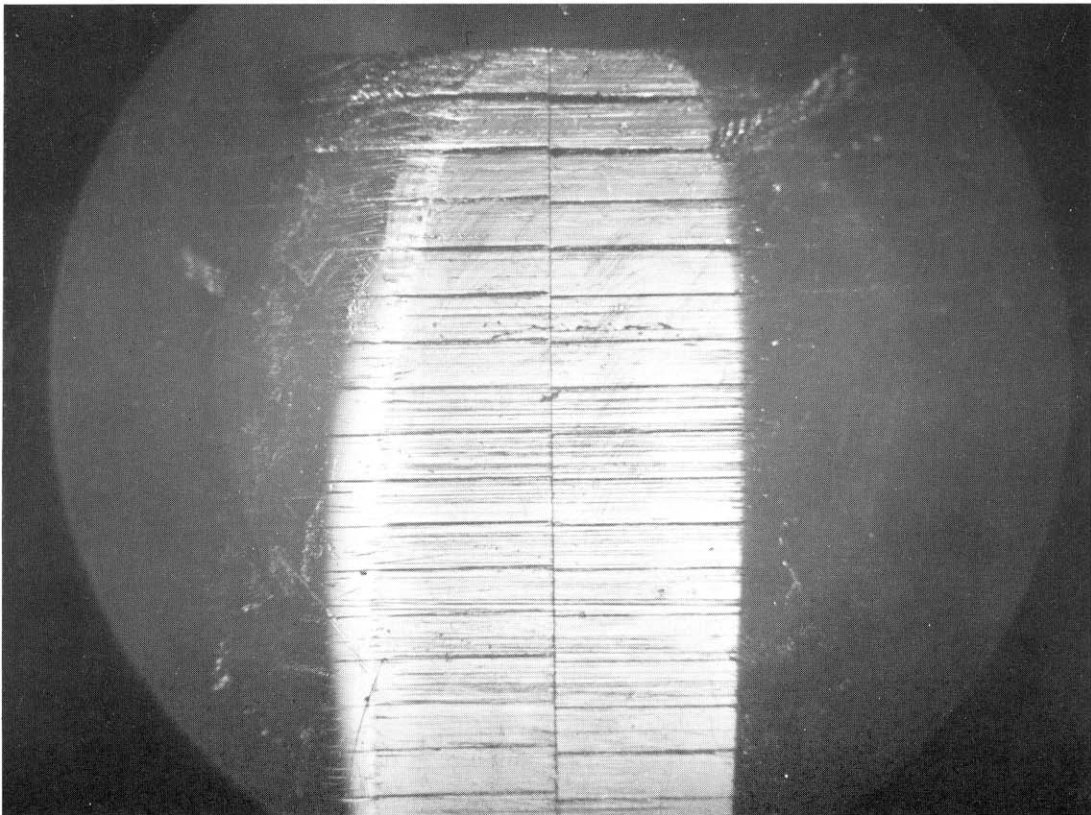

Figure J – Drumhead wear pattern.



Figure K – Shadow graph of worn drumhead showing concave area at gap.

some double system drum head recorders operate with a spring loaded head which bears upon the magnetic film as it wraps around a drum. This arrangement produces a different type of wear pattern. Figures I, J and K indicate the concave pattern resulting from this system. Fig. K is a shadowgraph view taken from where the edge of the film would travel.

The contents of this laboratory manual contain only the most frequently requested data addressed to the compiler.

We invite you, the reader, to suggest topics that you would like to see included in possible forthcoming supplements to your data book.

If you would care to be notified of any forthcoming supplements or materials, please fill out the registration form below and mail to:

R. K. Morrison Illustrative Materials
819 Coventry Road
Kensington, California 94707

We will notify you of their availability and price.

lab book serial number _____

Name _____

Address _____
