

HiFi ENGINE[®]

For more Hi-Fi manuals and set-up information
please visit www.hifiengine.com

33 Control Unit Instruction Book

GUARANTEE

This instrument is guaranteed against any defect in material or workmanship for a period of twelve calendar months from the date of purchase.

Within this period we undertake to supply replacements free of charge for any parts which may prove on examination to be defective except as the result of misuse (including use with unsuitable ancillary equipment) accident or negligence.

Any set requiring service under this guarantee should be carefully packaged and consigned, carriage paid, to the main distributor for the country of purchase quoting the date and place of purchase. It must not be sent to any other distributor except by special arrangement.

This guarantee is valid only when these conditions are complied with and does not cover labour or carriage costs involved in any repair under the guarantee.

Contents	Page
Connections	4
Initial Checks and Operation	9
Installation	3
Introduction	2
Mains	8
Operation Summary	10
Pickup	5
Plugs	4
Radio	6
Specification	11-13
Tape	7

Illustrations	Page
Disc Adaptor Board	5
Installation Schematic	2
Mounting the Quad 33	3
Pickup and motor wiring	3
Plugs	4-5
Quad 33 controls	14
Quad 33 mains adjustment	8
Quad 33 rear panel layout	15
Quad 33 performance curves	13
Tape Adaptor adjustments	8
Tape Adaptor Board	7

Acoustical Manufacturing Co Ltd
St Peters Road Huntingdon England
Telephone Huntingdon (0480) 52561
Telex 32348 AB 32348 Quad G

QUAD is a registered trademark
3K1078/3

Introduction

The Quad 33 has been designed to provide the best possible quality of reproduction but it must be borne in mind that the standard of performance of the complete equipment will be limited by that of the poorest link in the chain. Thus, the power amplifier, gramophone motor, pickup, loudspeaker, etc., should all receive careful consideration if full advantage is to be taken of the capabilities of the pre-amplifier.

A complete installation is shown in Fig. 1 and the same basic arrangement will apply in whole or in part, whatever associated equipment is used with the Quad 33. Installation is quite straightforward and should present no difficulty to the intelligent enthusiast provided the following notes are observed.

Please note that three printed circuit boards from the Quad 33 are packed separately for safe transit. These must be inserted during installation. See Fig. 3 and also instructions contained in the packing.

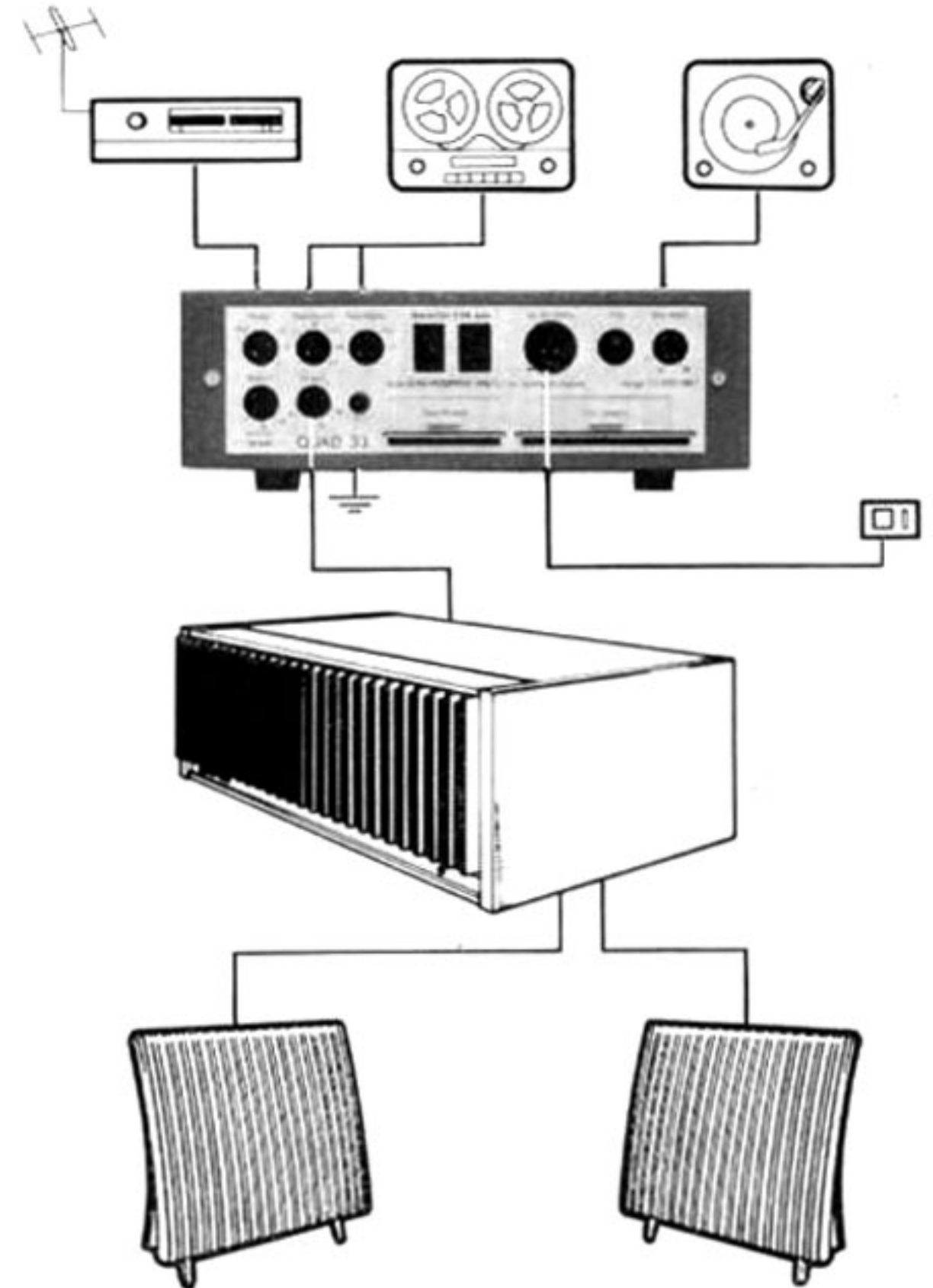

FIG. 1

Installation

Equipment of this type may be either mounted in a wide variety of housings or used free-standing, and if you are designing your own layout it might be advisable to assemble all the parts in a mock-up form before deciding on the final arrangement, just to make sure there are no unforeseen difficulties of operation or inter-unit wiring, etc.

Adequate ventilation must be provided for units producing heat, including transistorised power amplifiers and if the latter are to be mounted closer than about 12 inches from either control unit or tuner it might be necessary to experiment with orientation and position to ensure that no hum is induced in the latter units.

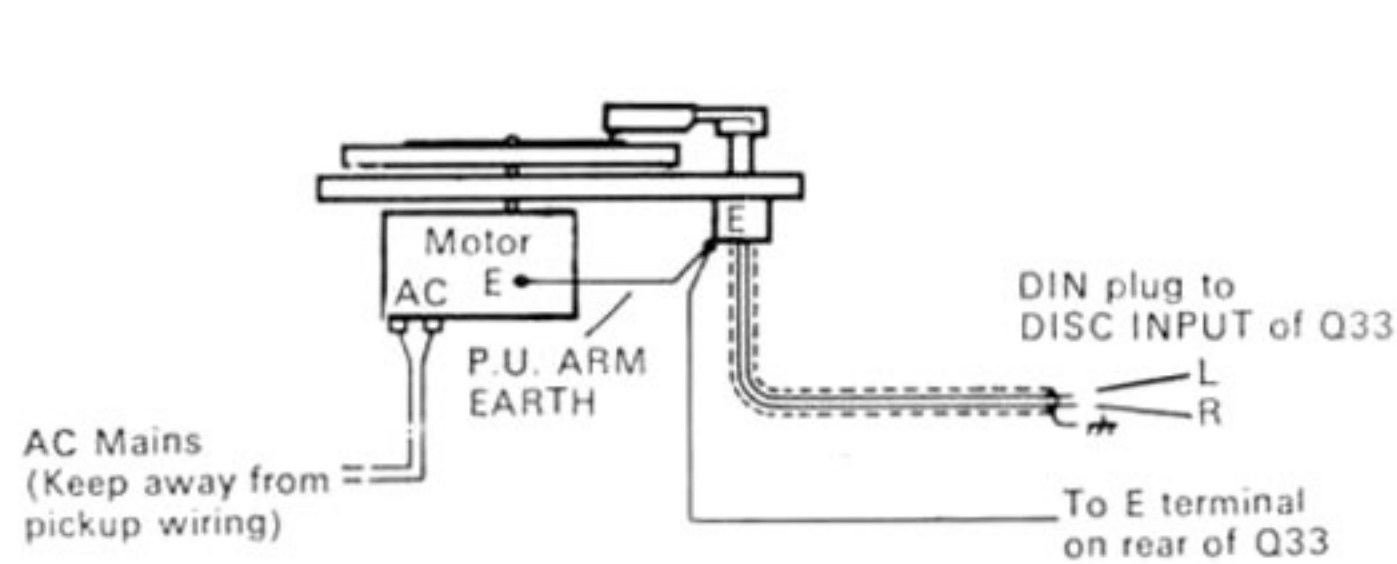

FIG. 2

Close proximity of the control unit and tuners to each other should cause no problem unless the control unit is mounted immediately on top of the tuner, in which case a space of about 50 mm should be left between them.

Hum can also occur if a low output magnetic pickup is too close to a mains transformer or if its leads run close to the mains wiring. (See Fig. 2.)

All metal parts must be earthed but, because multiple earth connections cause hum, they should be earthed, directly or indirectly, by one connection only, and the whole installation earthed at one point such as the E terminal on the rear of the control unit, OR the third pin of the control unit mains socket, but not both.

(Note: All the Quad units are already bonded together by their own inter-connecting cables).

Always follow the manufacturers' instruction supplied with pick-up, motor, tape recorder, etc., and refer any query which may arise to your dealer or in case of difficulty to the manufacturer concerned.

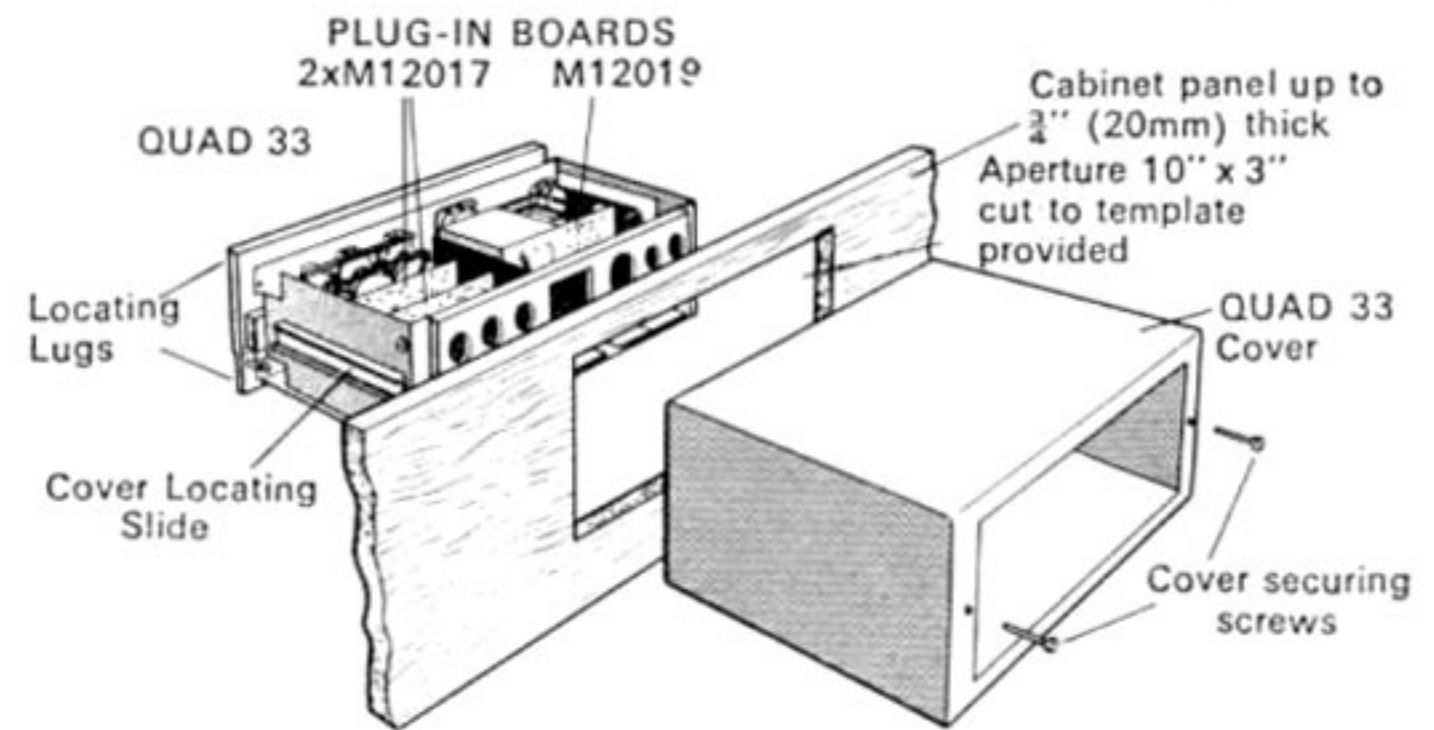

FIG. 3

If the Quad 33 is not to be used free standing you will require an aperture 255 mm \times 76 mm as shown in Fig. 3 and a template is provided in this booklet to assist in marking this out on the cabinet. The cover is then removed from the Quad 33, the unit passed through the aperture from the front so that

its lugs locate in the aperture, and the cover replaced from the rear, thus gripping the cabinet panel between the Quad 33 front casting and its cover. The securing screws should be inserted finger tight and then given one further half-turn to lock the unit firmly in position.

Where the cabinet panel thickness exceeds 12mm and there is a strong hum field present, hum may be found to enter the Quad 33 via the gap between its front panel and its cover.

In such cases the simplest remedy is usually to reduce the thickness of that part of the cabinet panel. Alternatively, the aperture may be lined with metal foil bonded to the Quad 33, but preferably insulated to avoid accidental contact with internal circuitry.

More usually hum is found to be due to external connections such as the pick-up wiring, earthing arrangements, mains wiring lying too close to either the pick-up wiring or the Disc Adaptor board, etc., in which case the hum level will increase as the volume control is advanced. If it does not, the source lies after the volume control and is probably internal, but if it occurs only with the 5, 7 or 10K buttons pressed it is probably being induced by a strong source such as a mains transformer immediately below the control unit.

Do not forget to plug in the three printed circuit boards packed separately for safe transit and to pack them similarly should it be necessary at any time to return the control unit for servicing.

CONNECTIONS

Control Unit to Power Amplifier

Two leads are supplied with the control unit. That with a 4-pin connector at each end is reversible and connects the control unit output to the power amplifier input. The other connects the switched mains supply from the control unit to the power amplifier and the 2-pin plug at the control unit end of this lead is reversible. Longer leads are permissible where required for special installations (see Specification on page 12). Where power amplifiers of other makes are used it may be necessary to change the connectors to suit.

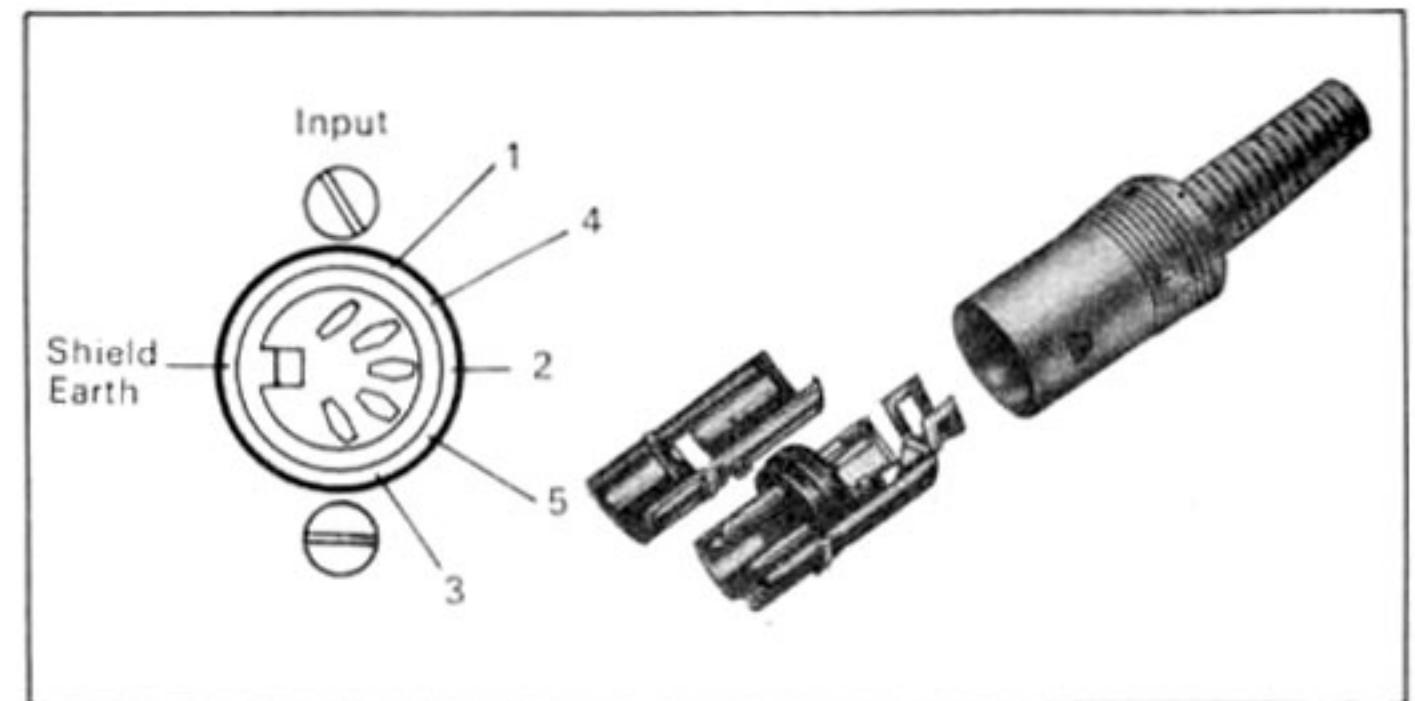

FIG. 4

Din style plugs showing method of assembly. See individual illustrations for pin connections.

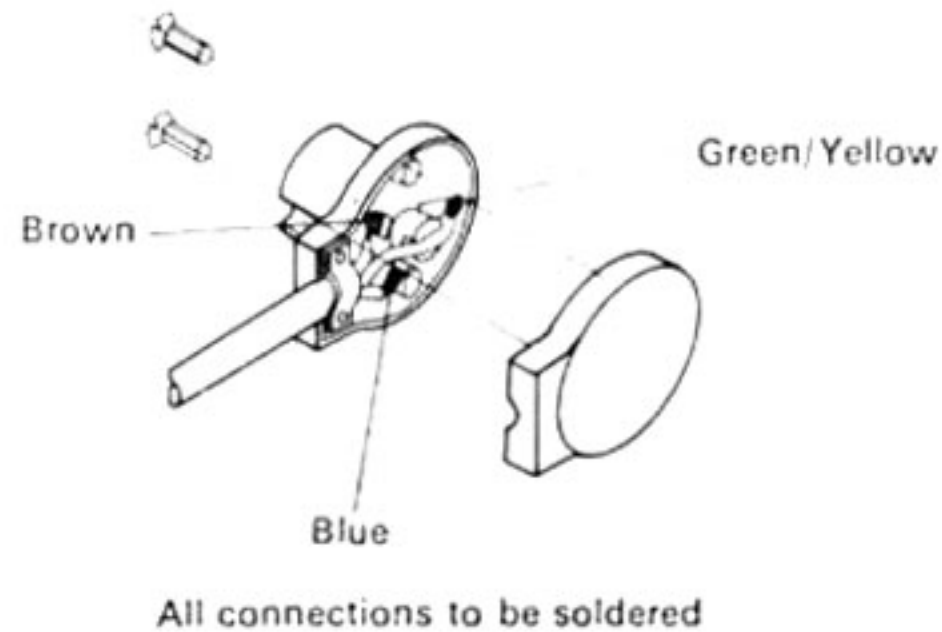

FIG. 5 Mains plug assembly.

Pickup (Disc) Input (See Fig. 6)

The pickup input is via a 5-pin plug and the same connections are used for all types of pickup. The necessary change in input circuitry to suit different types of pickup is achieved by the **Disc Adaptor Board**. This board provides matching for pickups of low output magnetic types (M1), high output magnetic types (M2), ceramic types (C1), and spare position (S1), according to the edge inserted into the holder. (See Specification on Page 12.)

Most currently available magnetic pickups require the M2 position but where doubt exists whether it should be M1 or M2, the position which permits a volume control setting of about 6 with most records should be used.

The fourth position is to enable the amateur or professional engineer to provide any other circuit configuration he may require and it also provides, of course, facility for accommodating any new type of pickup which may be introduced, requiring a different input from existing types.

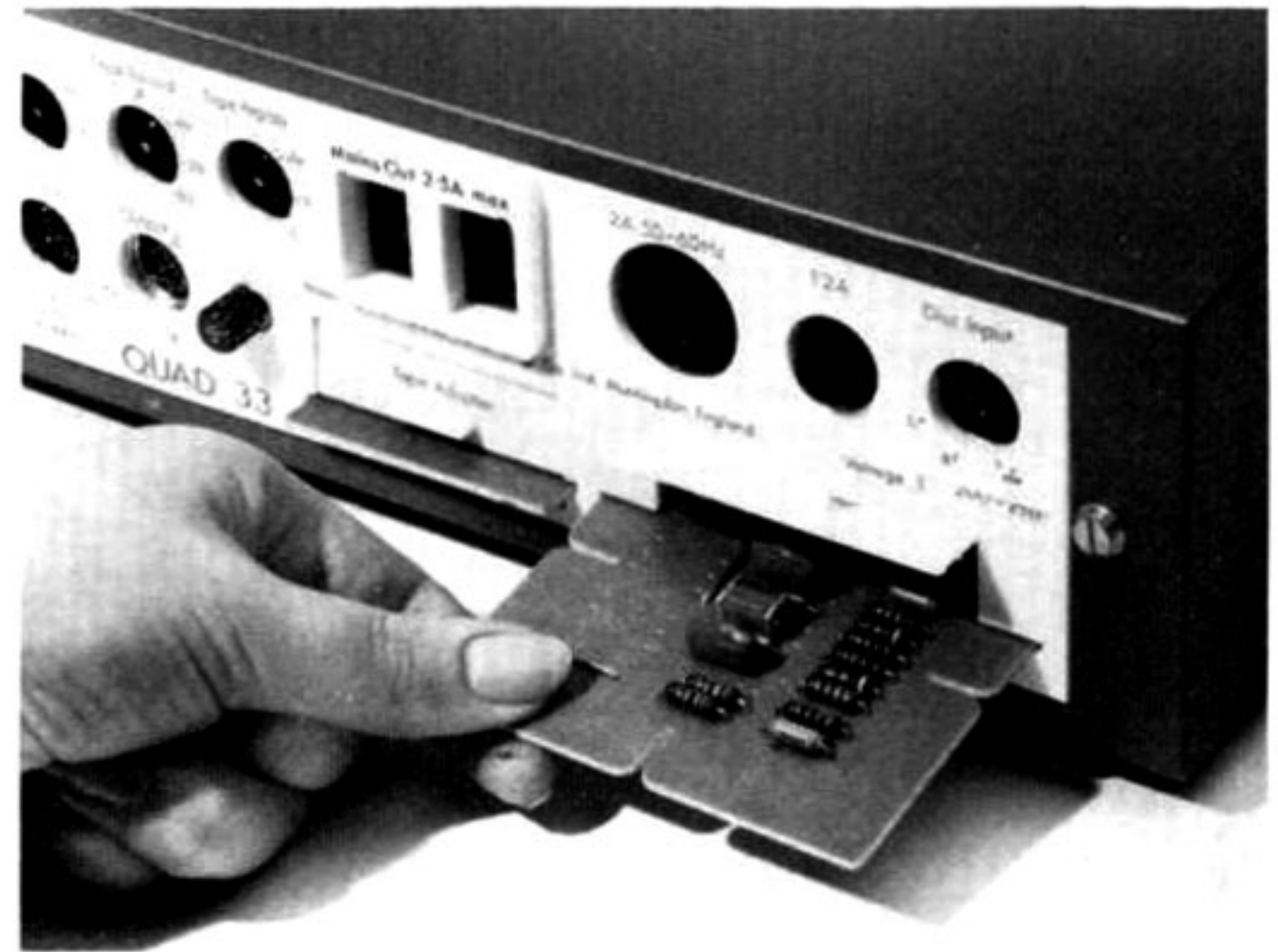

FIG. 6 DISC ADAPTOR BOARD

Radio (See Fig. 11)

Sockets are provided on the Quad 33 for two radio tuners to be connected. For example, an FM tuner, used for mono or stereo, may be connected to Radio 1 input and an AM tuner for long distance reception to Radio 2, or alternatively, Radio 2 may be used as an auxiliary input for other uses such as replaying from a tape recorder or microphone pre-amplifier with an output of 100mV. Quad self-powered tuners are supplied with the correct connectors and may be plugged in immediately. The connectors used on other self-powered tuners should be adapted as necessary and those already fitted with the same type of plug should be checked to ensure that the same connections are used. The output of such tuners should be suitable for the Quad 33 input of 100mV and 100K ohms (stereo) or 100mV and 50K ohms (mono).

The mains supply for these tuners should also be taken from the mains outlet sockets at the rear of the Quad 33.

WARNING

On no account should the HT/LT lead of earlier Quad tuners be connected to the power supplies sockets of the Quad 33 control unit. If such tuners are used a separate power pack must be provided.

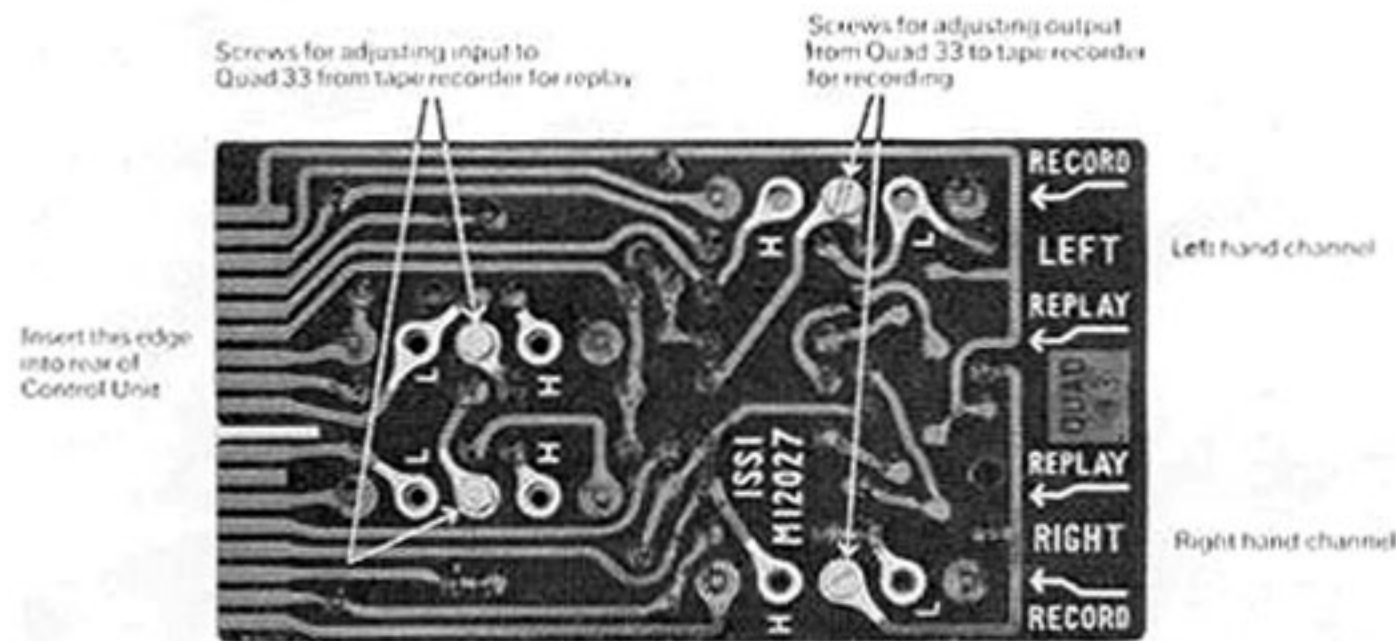

FIG. 8 TAPE ADAPTOR ADJUSTMENTS

Mains Input (See Figs. 5 & 9)

A 3-pin connector is provided for the control unit and this should be wired to the mains supply using a suitable grade of flexible cable. In countries where an earth connection is not used or where an external earth is connected to the E terminal of the control unit the third pin of the plug should be left blank.

The Quad 33 is supplied wired either for 100–130 volts or for 200–250 volts AC, but to convert from one range to the other involves merely removing the red coiled lead at the rear of the mains transformer from its existing position and resoldering it to the appropriately marked adjacent tag. (See Fig. 9.)

Mains Outlets

These sockets are intended for supplying the power amplifier and the FM stereo tuner. Normally it will be more convenient to run the mains supply direct to tape recorder and gramophone motor since these incorporate their own on/off switching, but if other units are run off the Quad 33 mains outlets the total current must not exceed 2.5 amps (or 5 amps on 110 volt supplies) changing the Quad 33 fuse where necessary.

The voltage of the supply from these outlets will, of course, be that of the mains supply to the Quad 33 input.

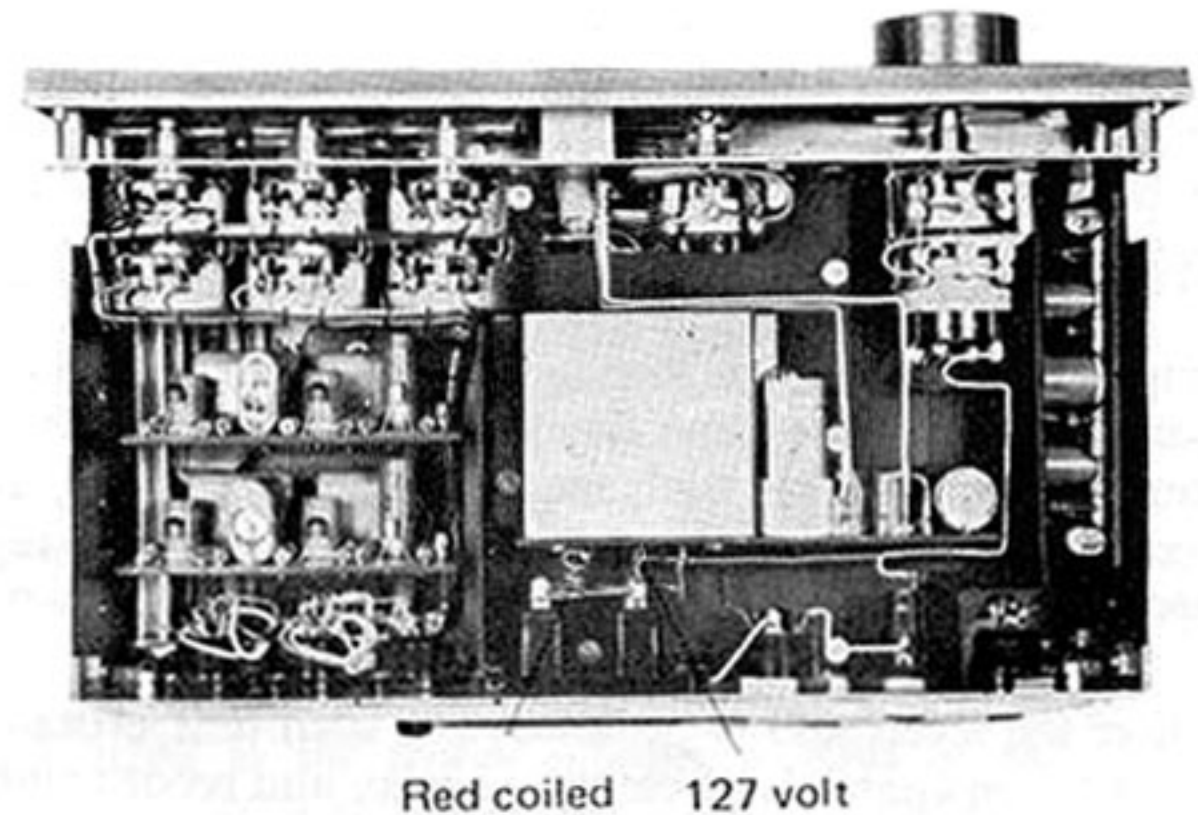

FIG. 9

Initial Checks and Operation

Before connecting the mains supply ensure that the voltage marked on the rear of the control unit, adjustments provided on tuners, power amplifier, etc., fed from it, and the value of fuses fitted are correct for your mains supply. Rotate the volume control switch on and note that the Quad name on the front panel lights, together with any other similar indicators on other units.

Pushbuttons (See also Filters)

The input (Radio 1, Radio 2, Tape replay or Disc) and the service (Stereo, or Mono on left-hand speaker, right-hand speaker or both), are selected by pressing the appropriate pushbuttons.

With Stereo pressed, all inputs are connected for stereo reproduction. In the case of radio, the tuner will automatically switch to Stereo when a stereo signal is received, reverting to Mono at all other times.

Pressing either or both of the Mon buttons will reproduce a mono signal from Disc or Radio 1 whether the programme source is mono or stereo. With Radio 2 or Tape inputs, however, apart from selecting loudspeakers, the Mon buttons also select left or righthand inputs, each to its own speaker. In addition,* either input may be reproduced over both speakers by pressing the Stereo button as well as the ← Mon or Mon → button and, of course, Radio 2 or Tape.

This facility was not available prior to serial number 7500.

Volume Control

The volume control is advanced to the appropriate level, bearing in mind that apart from enabling a level of sound to be obtained which suits the listening conditions of the moment, the volume control also has the important function of adjusting the intensity of sound so that it is currently related to the perspective of the recording or broadcast. This is obviously important for realistic reproduction.

For example, if a voice is picked up close to a microphone in a very absorbent studio, then on reproduction that voice will take up a position at the centre of, and in the plane of the loudspeakers. For natural sound, therefore, the loudspeakers should radiate similar power to that of the original voice. If on the other hand the voice is picked up some way from the microphone in a more live studio, then the voice on reproduction will take up a position some distance behind the loudspeakers and it is clear that the power required for natural sound is now very much less. The position or perspective of the reproduced sound is fixed at the studio end and there is little that can be done at the listening end to alter it. It follows that the volume setting for natural sound is to a large extent fixed at the studio end.

Filters (See curves on page 13)

The filters affect the extreme harmonic range only and do not interfere with musical brilliance. Their purpose is to enable the maximum content of the programme to be reproduced with the minimum distortion.

With most types of recording the distortion rises rapidly at high frequencies and the wider the loudspeaker range the more audible this will be. It may be removed or mitigated by rotating the filter slope control anti-clockwise from the level position. As the control is rotated, the quality and "cleanness" of the reproduction will improve. There will, however, be a point beyond which further rotation degrades the sound due to loss of the useful harmonic range.

The pushbuttons marked 5K, 7K and 10K, determine the frequency at which filtering commences and that marked 7K is the most useful for modern recordings. Pressing the 5K pushbutton transposes the filter operation to a lower frequency for use with older recordings and pressing the 10K pushbutton transposes it to a higher frequency where it is useful with very good records or high quality radio transmissions.

The Cancel button bypasses the bass, treble and filter controls to give a level response. This position is a reference by which the effects of the settings of the other controls may be judged without upsetting the position of these controls.

Bass and Treble Controls (See curves on page 13)

The musical balance of a programme is carefully adjusted during recording or broadcasting and adjustment of the bass and treble controls should not normally be necessary unless an inferior loudspeaker or the listening environment produces some effect which needs correction. Once set for a particular installation, therefore, these controls should be little used. Small deviations of the bass control will affect very low notes only. Greater deviations affect not only the very low notes to a greater extent but also the high bass notes. The treble control affects brilliance.

Balance Control

This merely adjusts the balance of the two channels and after initial adjustment it should require no alteration for normal listening unless a misbalanced recording or broadcast is to be reproduced, which is unusual, or unless the position of the loudspeakers or their environment is changed.

Operation Summary

With all the tests detailed in the previous section completed, operation of the Quad 33 should now be readily apparent and completely straightforward. It may be summarised as follows:—

Use the pushbuttons to select input and system required.

Adjust the volume control for a level of sound suitable for the programme.

Adjust the filter to obtain the best quality inherent in the programme remembering that this means filtering as little as possible.

Adjust bass and treble controls only if it is necessary to alter the musical balance of the programme.

Adjust the balance control only if the programme levels of the two channels are themselves out of balance.

Service

Normally the dealer supplying the equipment will be able to assist with advice or any attention the equipment may require but in case of difficulty you should return any Quad unit you wish to have checked, direct to our Service Department, or that of our main importer in the country concerned, carriage paid and preferably packed in its original carton.

Do not forget to enclose a note giving your name and address, full details of the reason for returning the unit and all the symptoms you have observed.

Specification for Quad 33 Control Unit

DISTORTION:	All controls level, 0.5Vrms output, with any input		:	0.02%	} 30—10,000 Hz
	Any control settings and any level within overload ratings		:	0.1%	
RESIDUAL NOISE:	0—30 phon weighting 15.7kHz bandwidth controls level or cancel		:	—90dB	
FREQUENCY RESPONSE:	Any input, any output RIAA or flat as appropriate		:	± 0.5 dB 30—20,000 Hz	
TONE CONTROLS:	± 1 dB of published curves (see page 13)				
FILTERS:	To published curves at 5kHz, 7kHz and 10kHz (see page 13)		$\pm 5\%$		
INTER-CHANNEL BALANCE:	Within 1dB with volume control varied from maximum to —45db				
BALANCE CONTROL RANGE:	9dB either way				
CROSSTALK:	Dependant on input source impedances. Replay/record typically better than 70dB Interchannel typically better than 40dB		30—10,000 Hz		
WEIGHT:	3Kg.				
DIMENSIONS:	Width	260mm			
	Height	92mm free standing, 83mm panel			
	Depth	165mm free standing 140mm behind cabinet panel when mounted Allow a further 64mm beyond rear panel for connectors)			
POWER INPUT:	*100—130/200—260V 50—60 Hz 1.5 Watts.				

* According to the position of the soldered lead at the rear of the mains transformer. See p. 8

Specification for Quad 33 Control Unit Inputs (all voltages rms)		Recommended Source Impedance 1.	Load Impedance 2.	Input Level for 0.5V Main Output 3.	Maximum Input 4.	Signal to noise referred to level in Col. 3 0—30 phon weighting
RADIO		20K ohms or less	100K ohms	100mV	2V	85dB
TAPE REPLAY	H	any	40K ohms	1V	10V	85dB
	M	any	40K ohms	400mV	4V	85dB
	L	any	40K ohms	100mV	1V	85dB
DISC	M1	Low Output Magnetic 0.2—1mV/Cm/Sec.	68K ohms	2mV at 1kHz	40mV at 1kHz	70dB
	M2	High Output Magnetic 0.7—3mV/Cm/Sec.	68K ohms	5.6mV at 1kHz	120mV at 1kHz	80dB
	C1	Ceramic 450—800pF 25—80mV/Cm/Sec.	Special	100mV at 1kHz	1.2V at 1kHz	
	S	FOR SPECIAL REQUIREMENTS				

Outputs (all voltages rms)		Level	Source Impedance	Recommended Load Impedance	Maximum Cable Lengths (Using 20pF/ft Screened Lead)
TO POWER AMPLIFIER		0.5V	1K ohms	10K ohms or over	100 feet
TO TAPE RECORDER	H	100mV*	5K ohms	25K ohms or over	150 feet
	M	20mV*	800 ohms	any	any
	L	3.7mV*	180 ohms	any	any

* 30% programme modulation

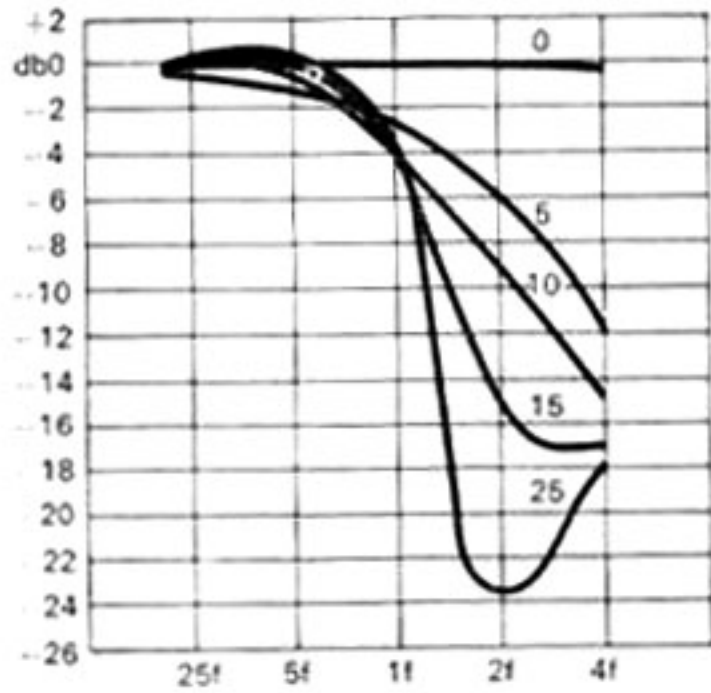

As the Filter slope control is rotated from 0 to 25 the filter swings from a level response to a steep cut as shown. f is the frequency selected by the 5kHz, 7kHz or 10kHz push buttons.

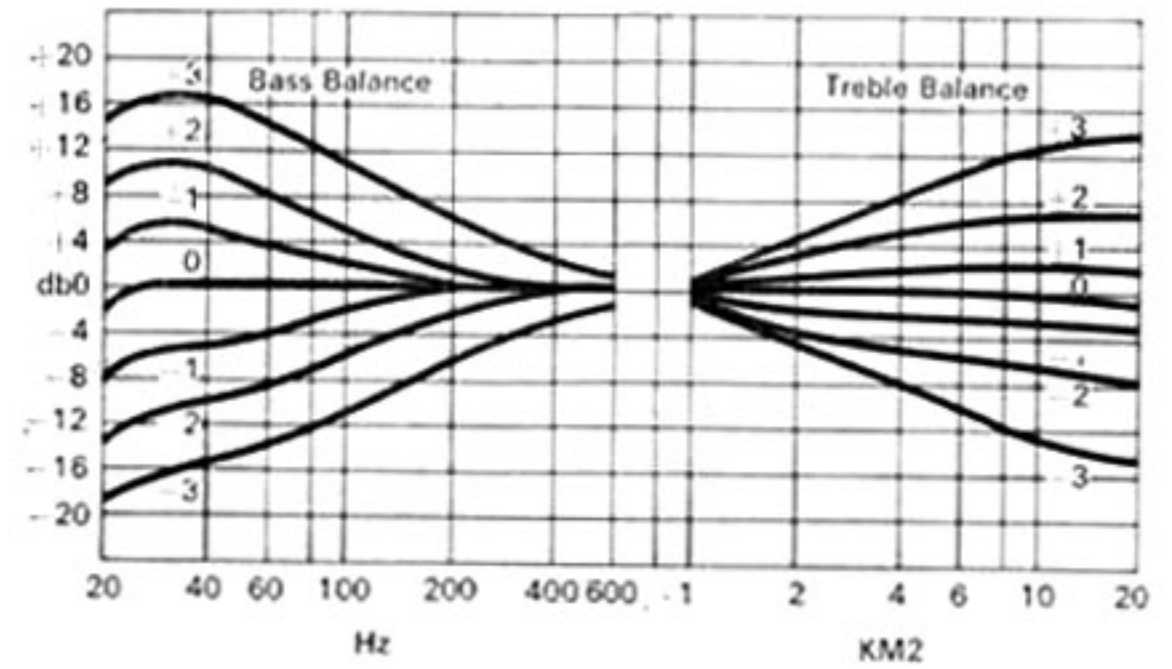

The Bass & Treble controls provide smooth and independent adjustment of the response to suit programme or environment

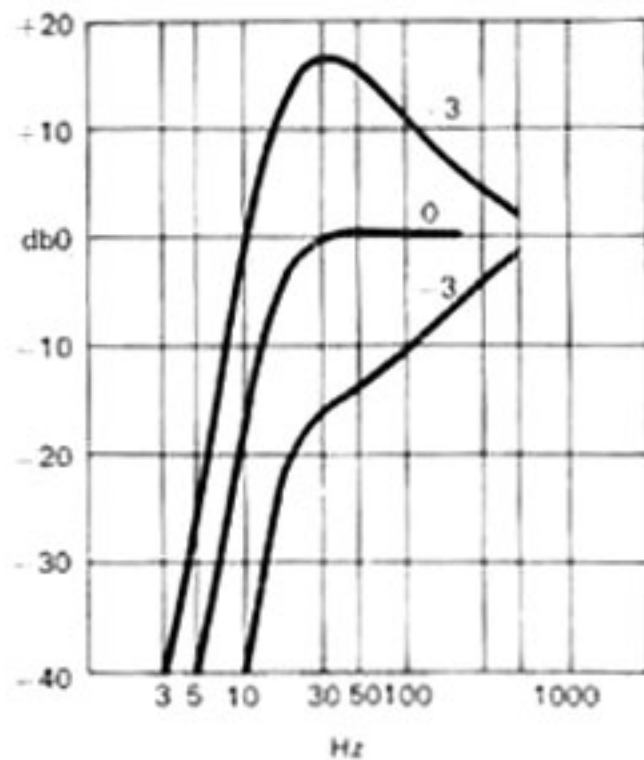

All sub-audio signals below 20Hz are drastically filtered as shown. The three curves correspond to minimum level and maximum settings of the Bass control.

**QUAD 33
PERFORMANCE
CURVES**

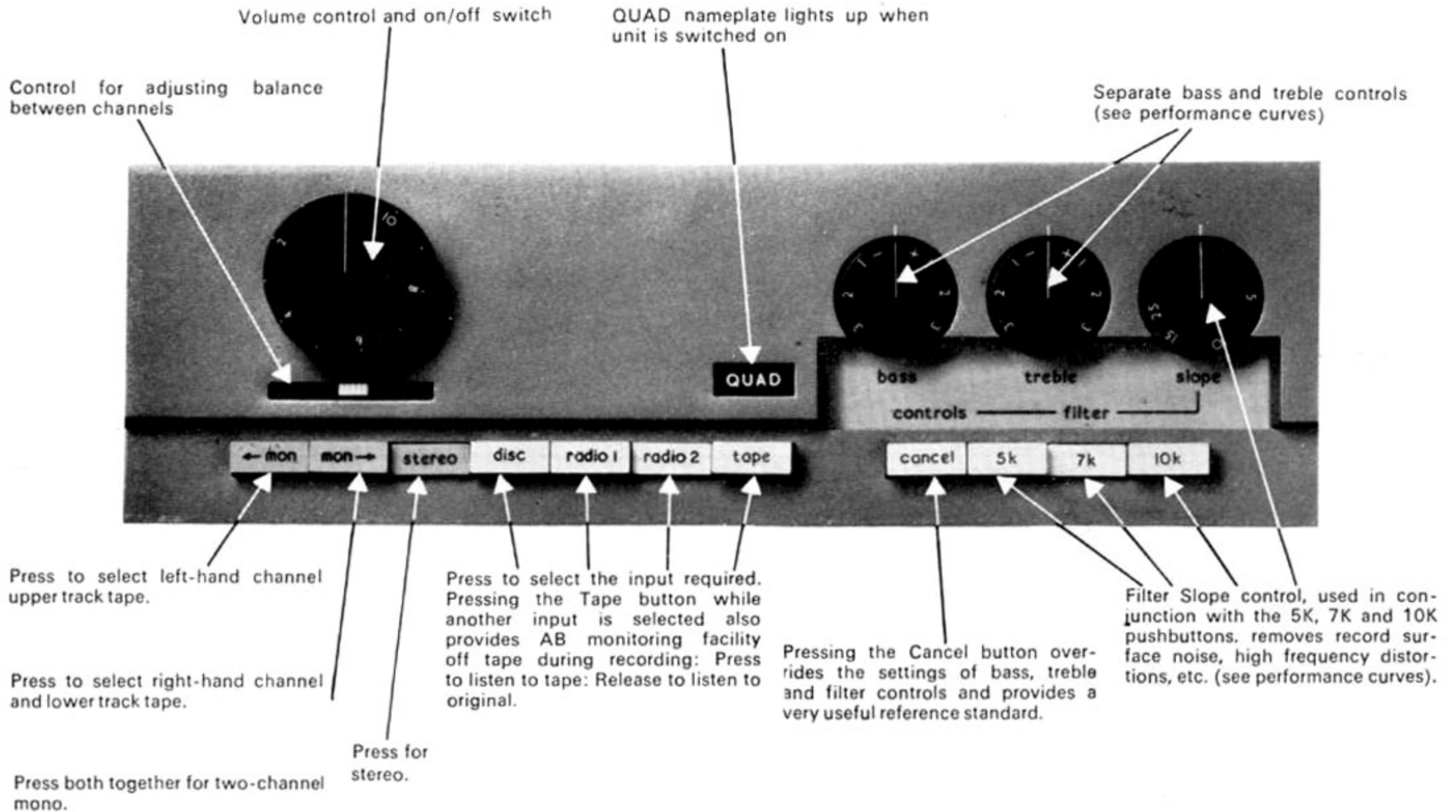

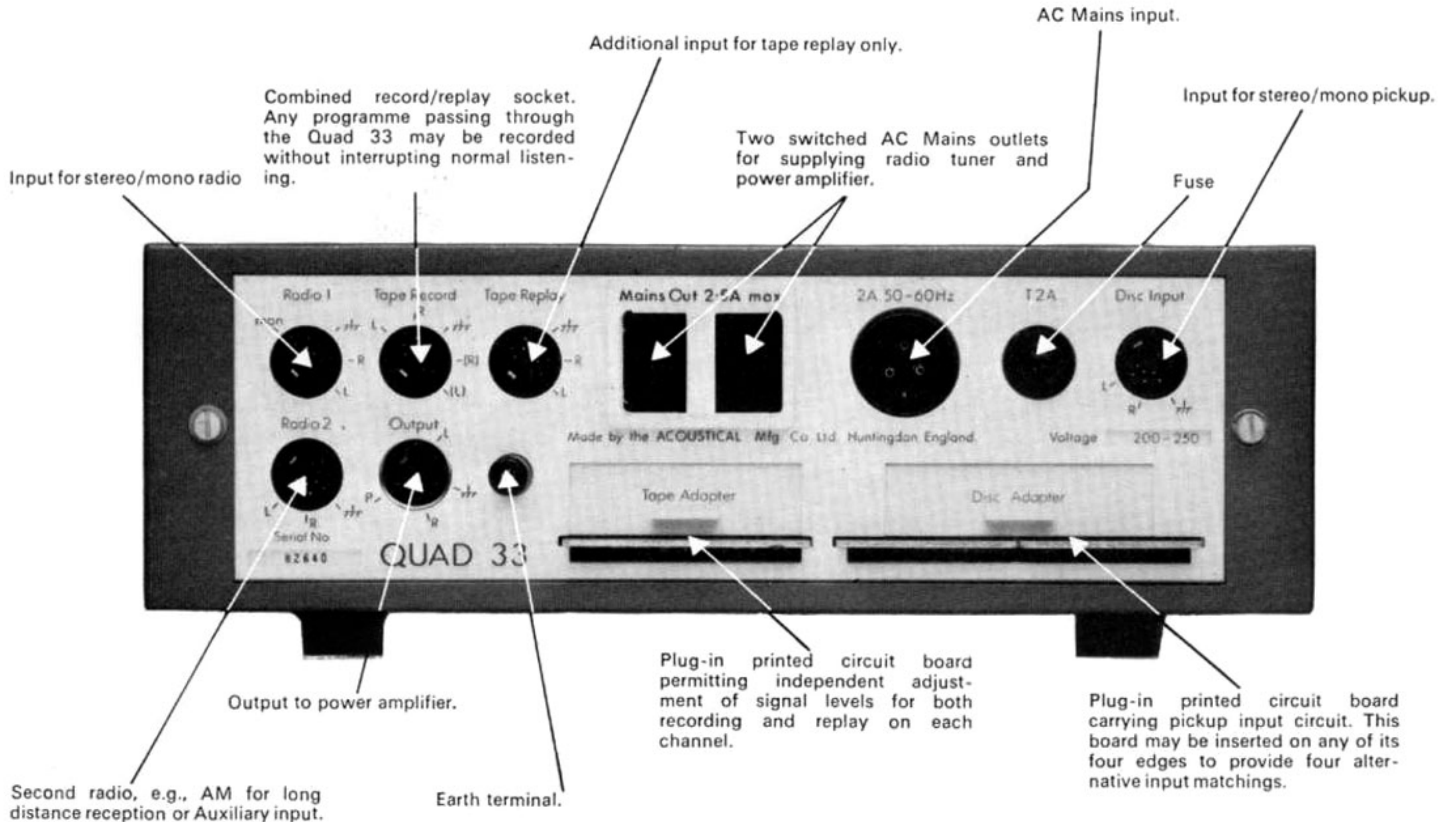

Combined record/replay socket. Any programme passing through the Quad 33 may be recorded without interrupting normal listening.

Additional input for tape replay only.

Two switched AC Mains outlets for supplying radio tuner and power amplifier.

AC Mains input.

Input for stereo/mono pickup.

Fuse

Input for stereo/mono radio

Output to power amplifier.

Earth terminal.

Second radio, e.g., AM for long distance reception or Auxiliary input.

Plug-in printed circuit board permitting independent adjustment of signal levels for both recording and replay on each channel.

Plug-in printed circuit board carrying pickup input circuit. This board may be inserted on any of its four edges to provide four alternative input matchings.

All signal connections comply with the internationally used DIN standards.

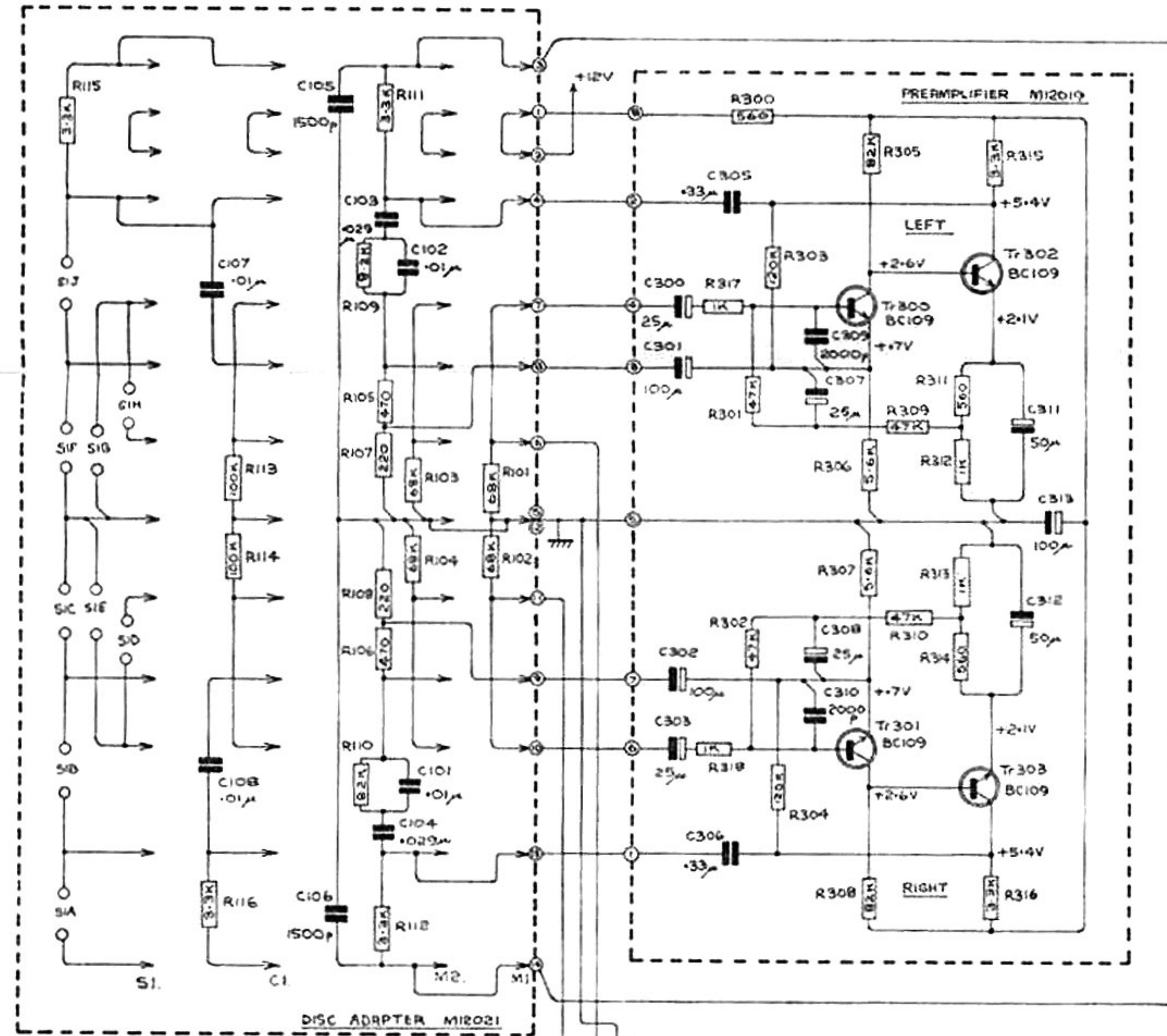
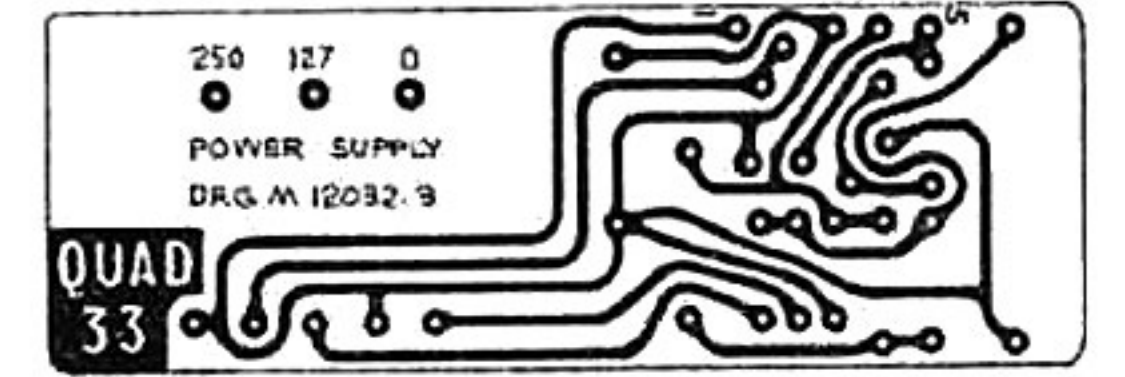
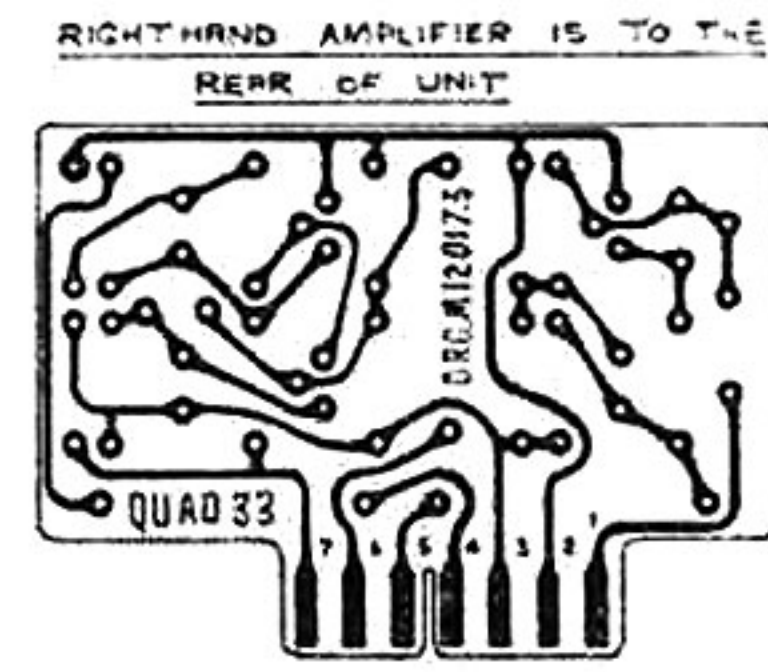
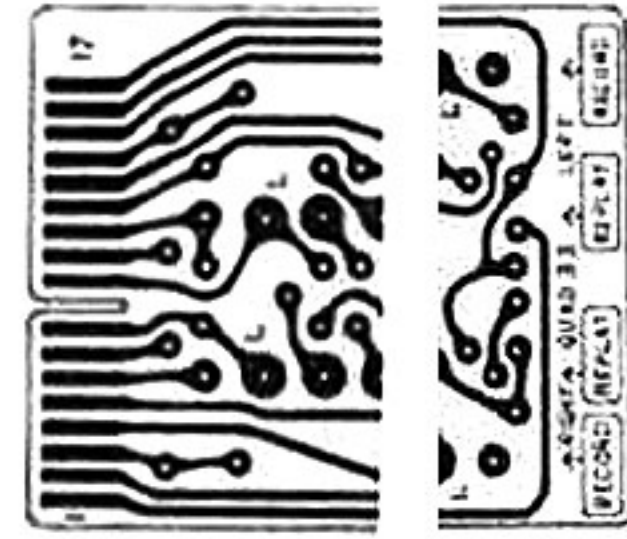
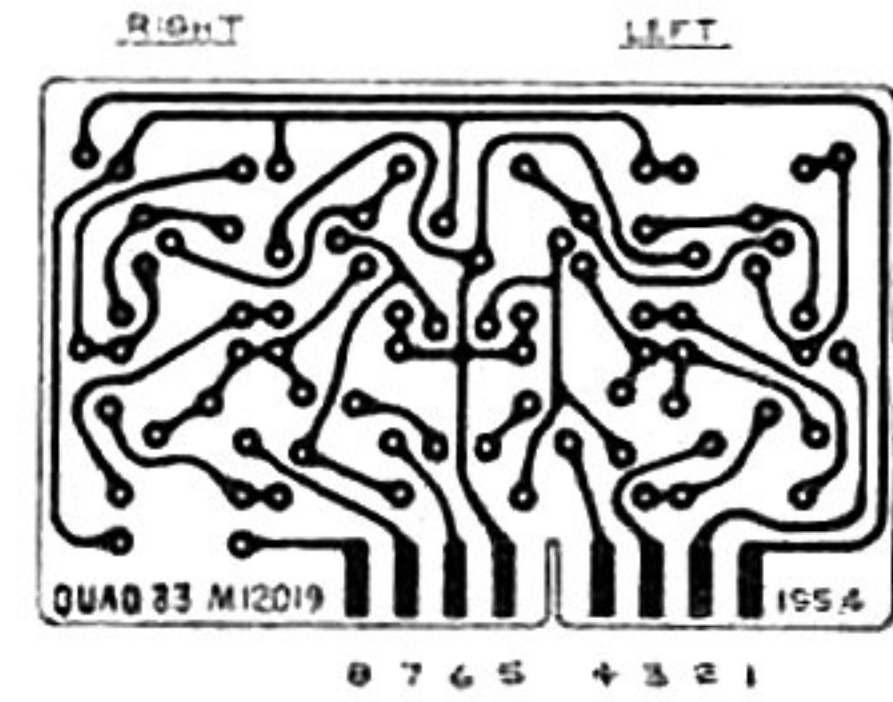
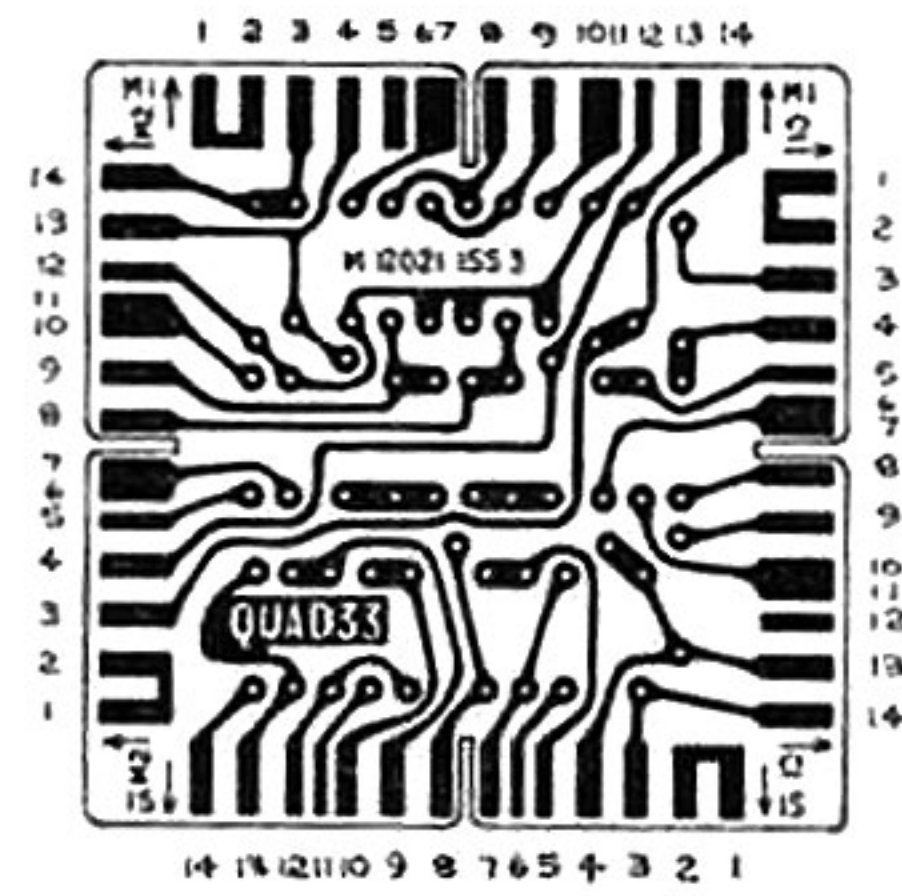

RESISTORS R105 TO R112 & CAPACITORS C101 TO C106 CHANGE CHANNELS IN M2 CONNECTION.

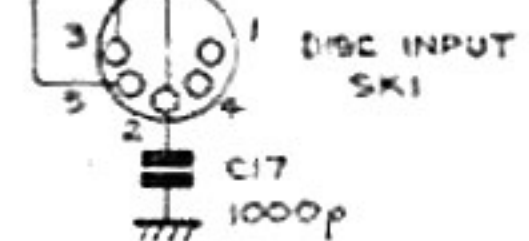

ALL INPUT CONNECTIONS ARE: PIN 2 - EARTH, PIN 3 - LEFT CHANNEL, PIN 5 - RIGHT CHANNEL.

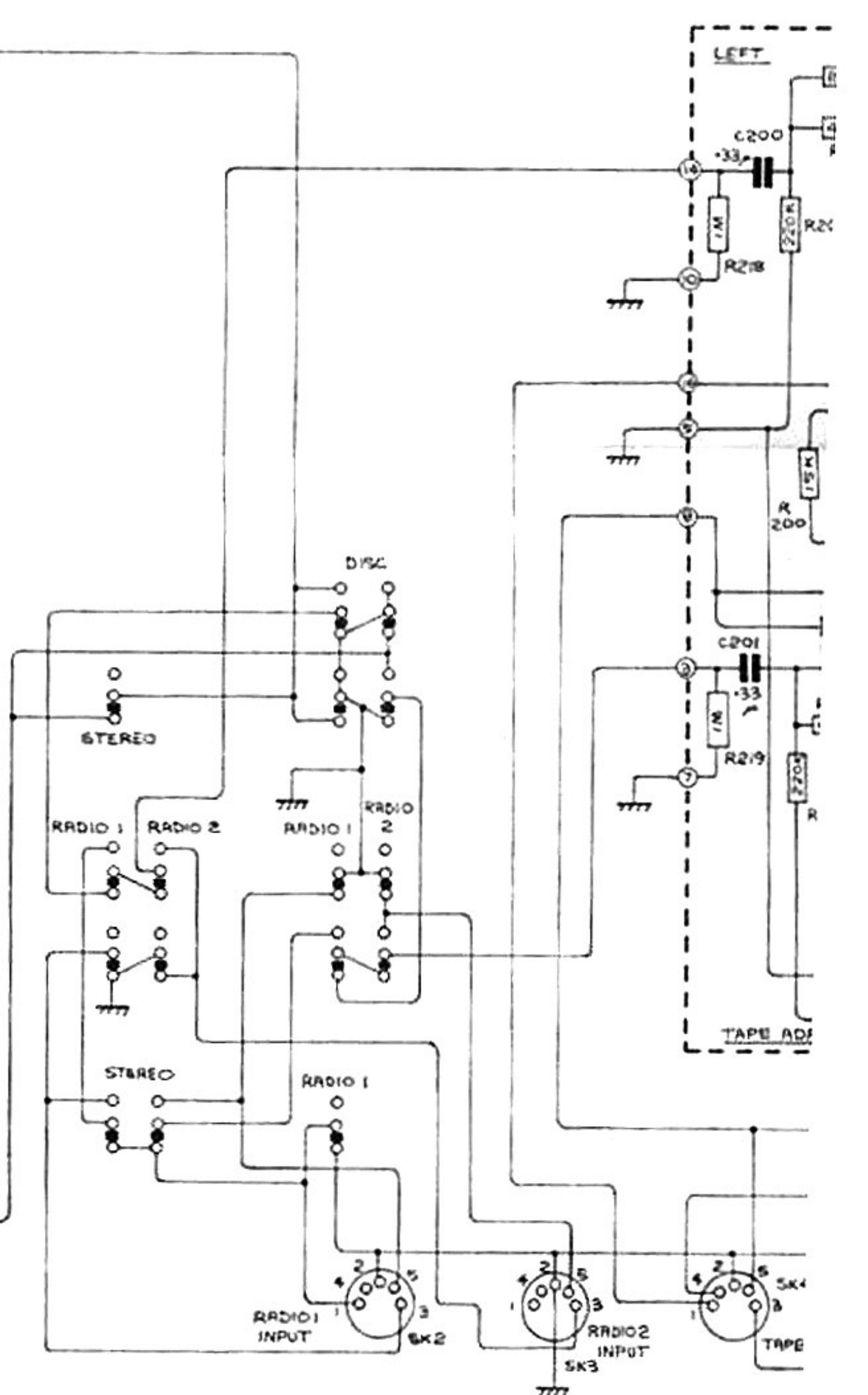

THE FRONT SECTION OF EACH DUAL CONTROL IS IN THE LEFT CHANNEL.

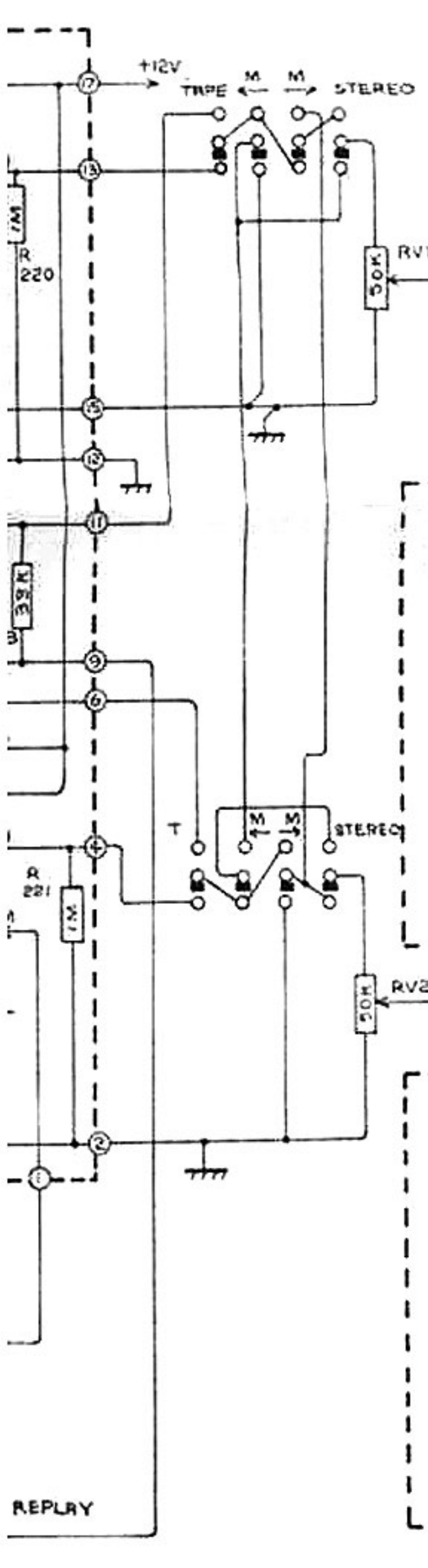

VOLTAGES SHOWN ARE APPROXIMATE AND ALLOWANCE SHOULD BE MADE FOR LOADING EFFECTS OF A VOLTMETER.

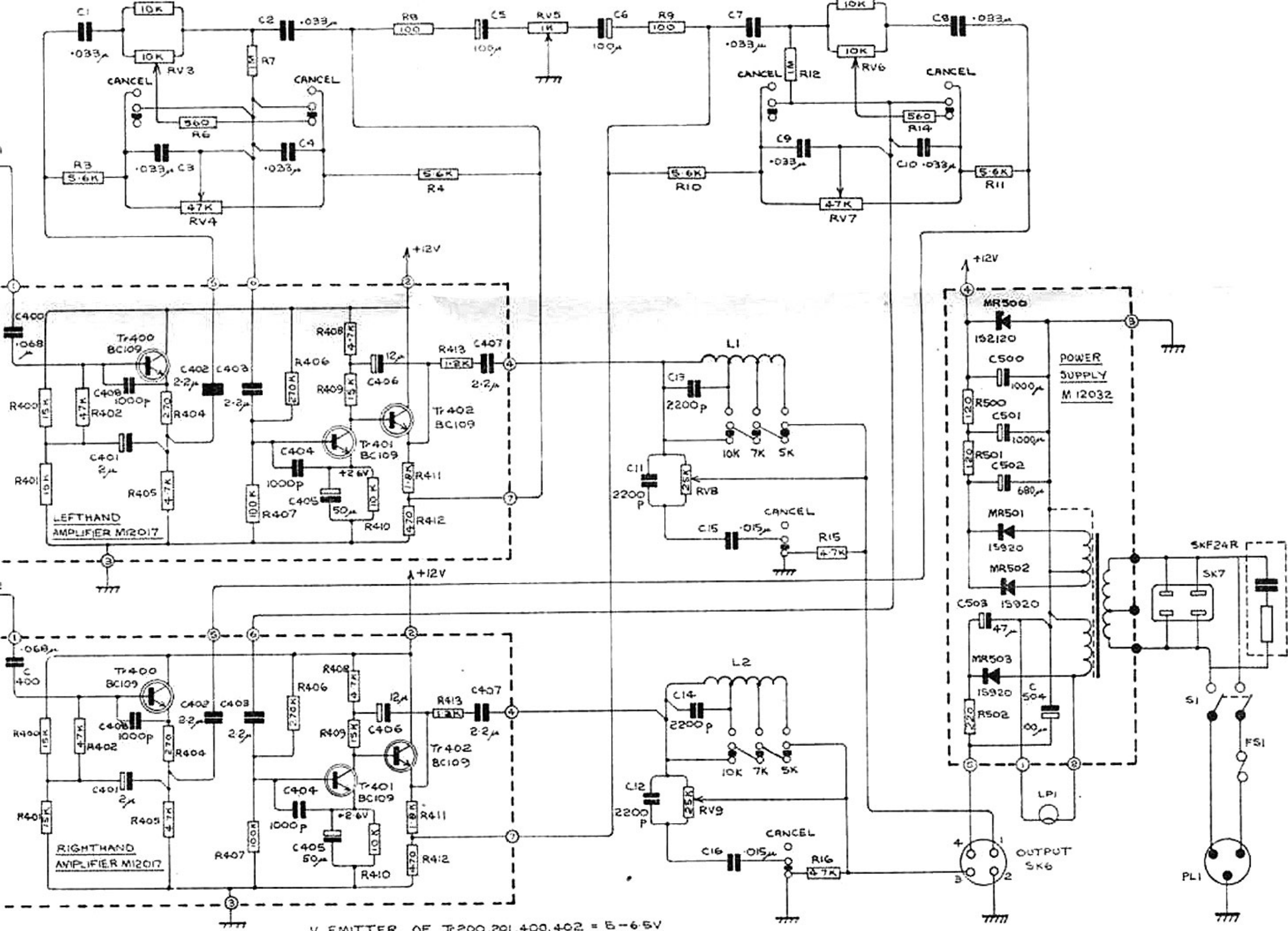

V EMITTER OF Tr 200, 201, 400, 402 = 5-6.5V