

HiFi ENGINE®

For more Hi-Fi manuals and set-up information
please visit www.hifiengine.com

Operating Instructions

STEREO AMPLIFIER

A-717

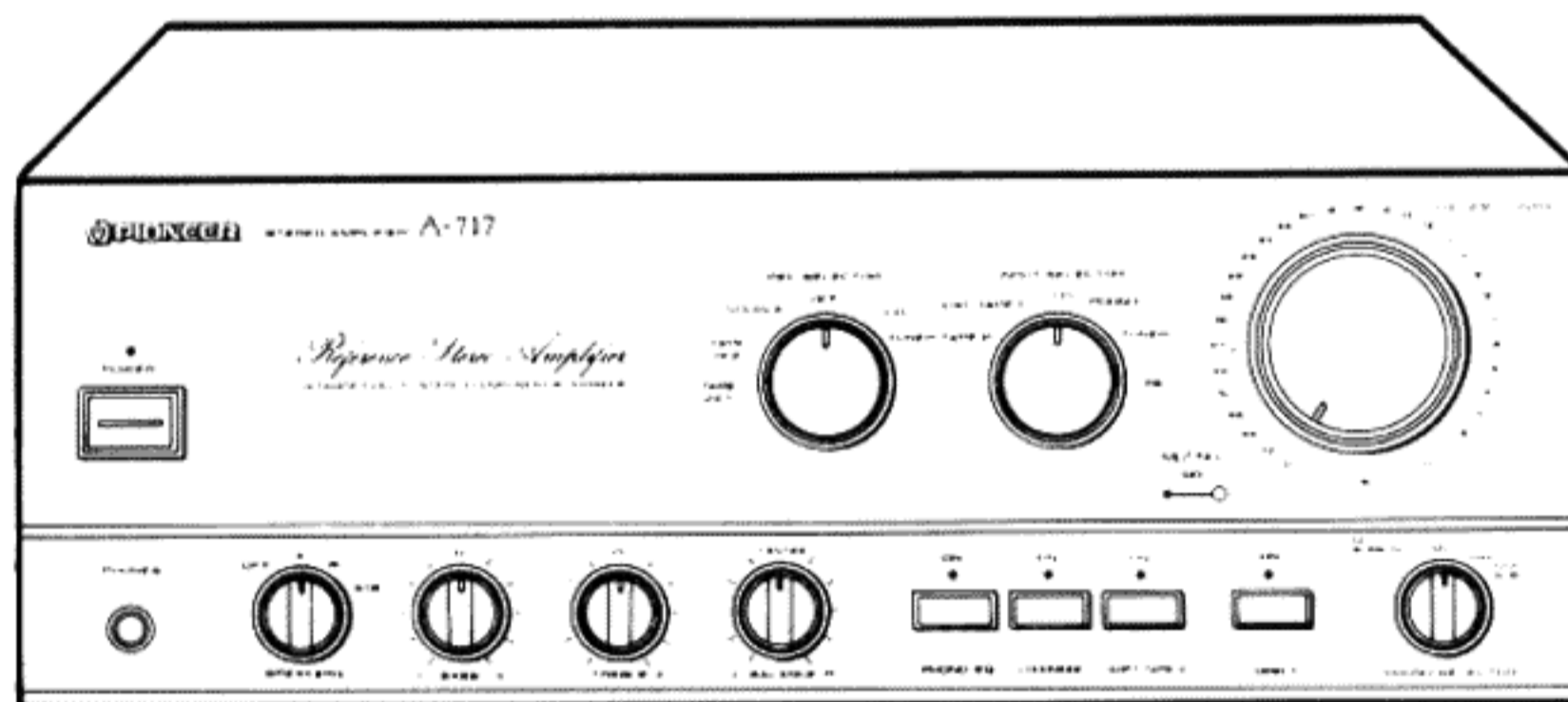

Thank you for buying this Pioneer product.

Please read through these operating instructions so you will know how to operate your model properly. After you have finished reading the instructions, put them away in a safe place for future reference.

In some countries or regions, the shape of the power plug and power outlet may sometimes differ from that shown in the explanatory drawings. However, the method of connecting and operating the unit is the same.

WARNING: TO PREVENT FIRE OR SHOCK HAZARD, DO NOT EXPOSE THIS APPLIANCE TO RAIN OR MOISTURE.

IMPORTANT NOTICE

[For U.S. and Canadian models]

The serial number for this equipment is located on the rear panel. Please write this serial number on your enclosed warranty card and keep it in a secure area. This is for your security.

[For Canadian model]

CAUTION: TO PREVENT ELECTRIC SHOCK DO NOT USE THIS (POLARIZED) PLUG WITH AN EXTENSION CORD, RECEPTACLE OR OTHER OUTLET UNLESS THE BLADES CAN BE FULLY INSERTED TO PREVENT BLADE EXPOSURE.

ATTENTION: POUR PREVENIR LES CHOCS ELECTRIQUES EN PAS UTILISER CETTE FICHE POLARISEE AVEC UN PROLONGATEUR UNE PRISE DE COURANT OU UNE AUTRE SORTIE DE COURANT, SAUF SI LES LAMES PEUVENT ETRE INSEREES A FOND SANS EN LAISSER AUCUNE PARTIE A DECOUVERT.

SAFETY INSTRUCTIONS

READ INSTRUCTIONS — All the safety and operating instructions should be read before the appliance is operated.

RETAIN INSTRUCTIONS — The operating instructions should be retained for future reference.

HEED WARNING — All warnings on the appliance and in the operating instructions should be adhered to.

FOLLOW INSTRUCTIONS — All operating and use instructions should be followed.

WATER AND MOISTURE — The appliance should not be used near water — for example, near a bathtub, washbowl, kitchen sink, laundry tub, in a wet basement, or near a swimming pool, etc.

LOCATION — The appliance should be installed in a stable location.

WALL OR CEILING MOUNTING — The appliance should not be mounted to a wall or ceiling.

VENTILATION — The appliance should be situated so that its location or position does not interfere with its proper ventilation. For example, the appliance should not be situated on a bed, sofa, rug, or similar surface that may block the ventilation openings, or, placed in a built-in installation, such as a bookcase or cabinet that may impede the flow of air through the ventilation openings.

HEAT — The appliance should be situated away from heat sources such as radiators, heat registers, stoves, or other appliances (including amplifiers) that produce heat.

POWER SOURCES — The appliance should be connected to a power supply only of the type described in the operating instructions or as marked on the appliance.

POWER-CORD PROTECTION — Power-supply cords should be routed so that they are not likely to be walked on or pinched by items placed upon or against them, paying particular attention to cords at plugs, convenience receptacles, and the point where they exit from the appliance.

POLARIZATION — If your purchased product is provided with a polarized power plug, please read the following instructions. This product is equipped with a polarized alternating current line plug (a plug having one blade wider than the other). This plug will fit into the power outlet only one way. This is a safety feature. If you are unable to insert the plug fully into the outlet, try reversing the plug. If the plug should still fail to fit, contact your electrician to replace your obsolete outlet. Do not defeat the safety purpose of the polarized plug.

CLEANING — The appliance should be cleaned only with a polishing cloth or a soft dry cloth. Never clean with furniture wax, benzene, insecticides or other volatile liquids since they may corrode the cabinet.

POWER LINES — An outdoor antenna should be located away from power lines.

NONUSE PERIODS — The power cord of the appliance should be unplugged from the outlet when left unused for a long period of time.

OBJECT AND LIQUID ENTRY — Care should be taken so that objects do not fall and liquids are not spilled into the enclosure through openings.

DAMAGE REQUIRING SERVICE — The appliance should be serviced by a Pioneer authorized service center or qualified service personnel when:

- The power-supply cord or the plug has been damaged; or
- Objects have fallen, or liquid has been spilled into the appliance; or
- The appliance has been exposed to rain; or
- The appliance does not appear to operate normally or exhibits a marked change in performance; or
- The appliance has been dropped; or the enclosure damaged.

SERVICING — The user should not attempt to service the appliance beyond that described in the operating instructions. For all other servicing, contact the nearest Pioneer authorized service center.

OUTDOOR ANTENNA GROUNDING — If an outside antenna is connected to the antenna terminal, be sure the antenna system is grounded so as to provide some protection against voltage surges and built up static charges.

In the U.S.A. section 810 of the National Electrical Code, ANSI/NFPA No. 70-1984, provides information with respect to proper grounding of the mast and supporting structure, grounding of the lead-in wire to an antenna discharge unit, size of grounding conductors, location of antenna-discharge unit, connection to grounding electrodes, and requirements for the grounding electrode. See Fig. A.

- a) Use No. 10 AWG (5.3 mm²) copper, No. 8 AWG (8.4 mm²) aluminum, No. 17 AWG (1.0 mm²) copperclad steel, bronze wire, or larger as ground wire.
 - b) Secure antenna lead-in and ground wires to house with stand-off insulators spaced from 4 feet (1.22 meters) to 6 feet (1.83 meters) apart.
 - c) Mount antenna discharge unit as closely as possible to where lead-in enters house.
 - d) Use jumper wire not smaller than No. 6 AWG (13.3 mm²) copper, or the equivalent, when a separate antenna-grounding electrode is used.
- See NEC Section 810-21 (j)

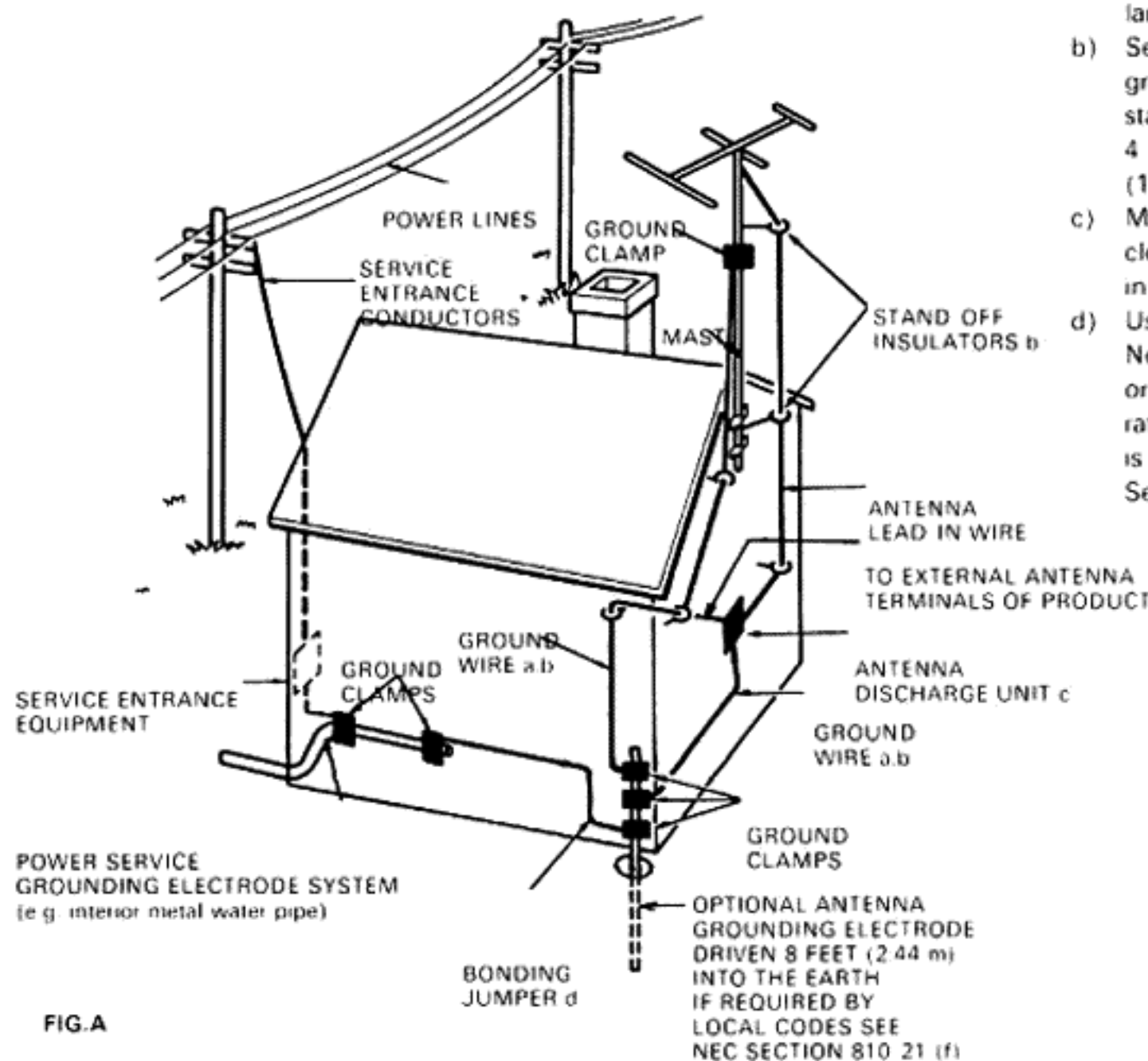

FIG. A

IMPORTANT 1



The lightning flash with arrowhead, within an equilateral triangle, is intended to alert the user of the presence of uninsulated "dangerous voltage" within the product's enclosure that may be of sufficient magnitude to constitute a risk of electric shock to persons.



CAUTION:
TO PREVENT THE RISK OF ELECTRIC SHOCK, DO NOT REMOVE COVER (OR BACK). NO USER-SERVICEABLE PARTS INSIDE. REFER SERVICING TO QUALIFIED SERVICE PERSONNEL.



The exclamation point within an equilateral triangle is intended to alert the user of the presence of important operating and maintenance (servicing) instructions in the literature accompanying the appliance.

IMPORTANT 2

If the apparatus is fitted with AC mains power outlet(s), see REAR PANEL FACILITIES for convenient connection of additional Hi-Fi component(s). Make all connections to the AC outlet(s) and the signal terminals first. Connect the plug to the wall socket last, make sure that the power switch is off. Disconnect the wall plug when the equipment is not in (regular) use, e.g. when on vacation.

FOR USE IN THE UNITED KINGDOM

The wires in this mains lead are coloured in accordance with the following code:

Blue: Neutral
Brown: Live

As the colours of the wires in the mains lead of this apparatus may not correspond with the coloured marking identifying the terminals in your plug proceed as follows:

The wire which is coloured blue must be connected to the terminal which is marked with the letter N or coloured black.

The wire which is coloured brown must be connected to the terminal which is marked with the letter L or coloured red.

Equipment sold in the U.K. is not supplied with a power plug.

FEATURES

- Drive capacity 135W + 135W/4Ω (FTC), 100W + 100W/8Ω (FTC) matching to high power and low impedance type speaker system.
- The use of DIRECT circuit assures high fidelity playback of consistent frequency characteristics, accompanied by maximum clarity.
- REC SELECTOR switch makes tape editing very simple.
- Non Switching Circuit Type III is employed to realize high quality sound, with minimum distortion.
- Comes with a built in phono equalizer which accepts MC cartridge.
- Casted Power Transformer
- Honeycomb Frame Chassis
- Honeycomb Heat Sink

CONTENTS

Features	3
Connections	4
Connecting Cords	5
Panel Facilities	7
Operations	9
Troubleshooting	10
Specifications	11

CONNECTIONS

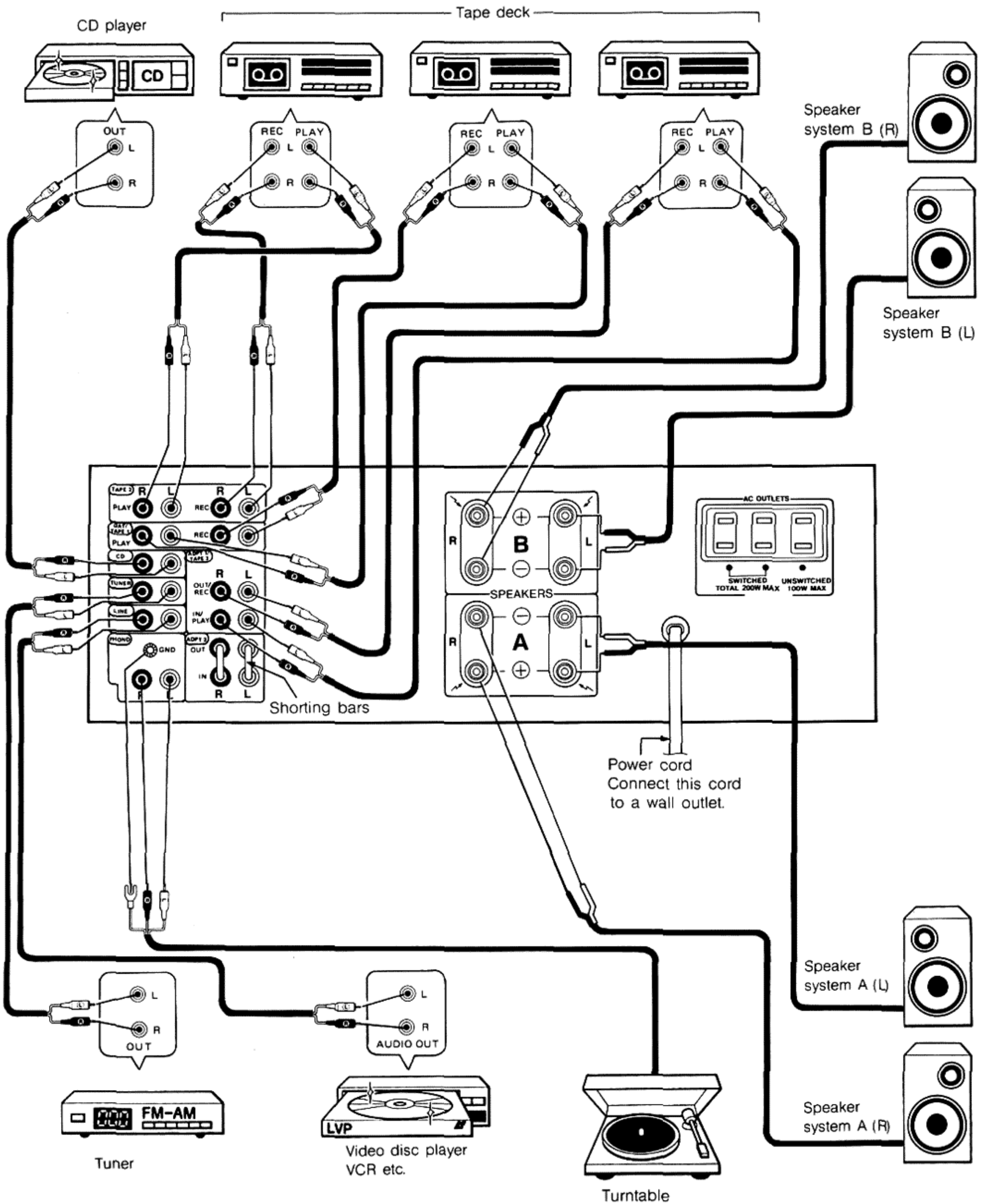

CONNECTING CORDS

CONNECTING SPEAKER CORDS

1. Strip off the vinyl covering and twist the tip of the wire cord.
2. Loosen the knob and insert the wire core into the terminal hole.
3. Tighten the knob to fix the wire core in place.

NOTE:

Do not allow the wire core to protrude and touch other terminals or wires. If the cores of differing wires touch, damage may be caused to your components.

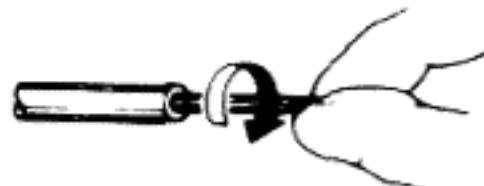

Twist the wire core.

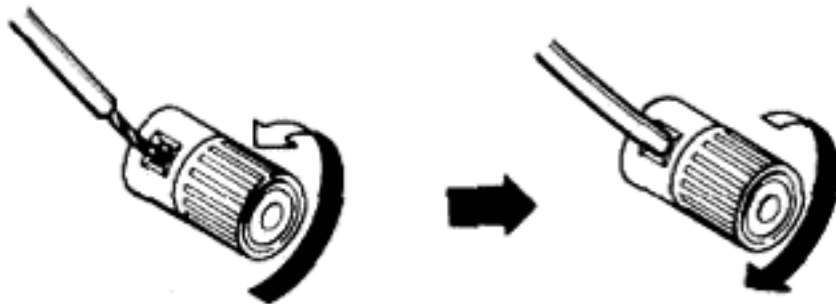

Speaker Impedance

When speaker systems are connected to only one of the SPEAKERS A or B terminals such speakers should have rated impedance in the range of 4-16Ω.

When speakers are connected to both the A and B terminals, they should have a rated impedance in the range of 8-32Ω.

CONNECTING INPUT/OUTPUT CORDS

Connect the white plug to the L (left) side, and the red plug to the R (right) side. Be sure to push the plugs in securely.

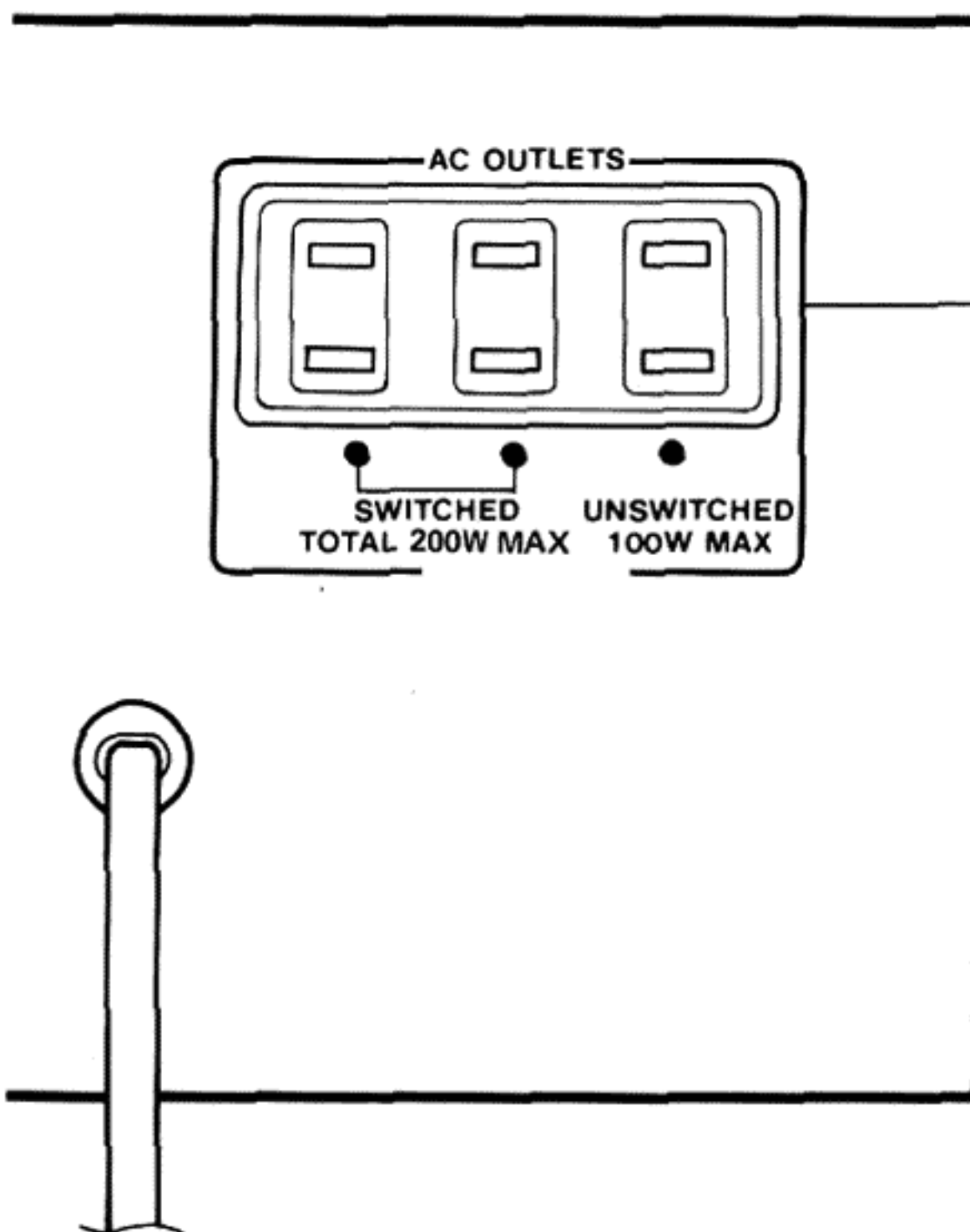
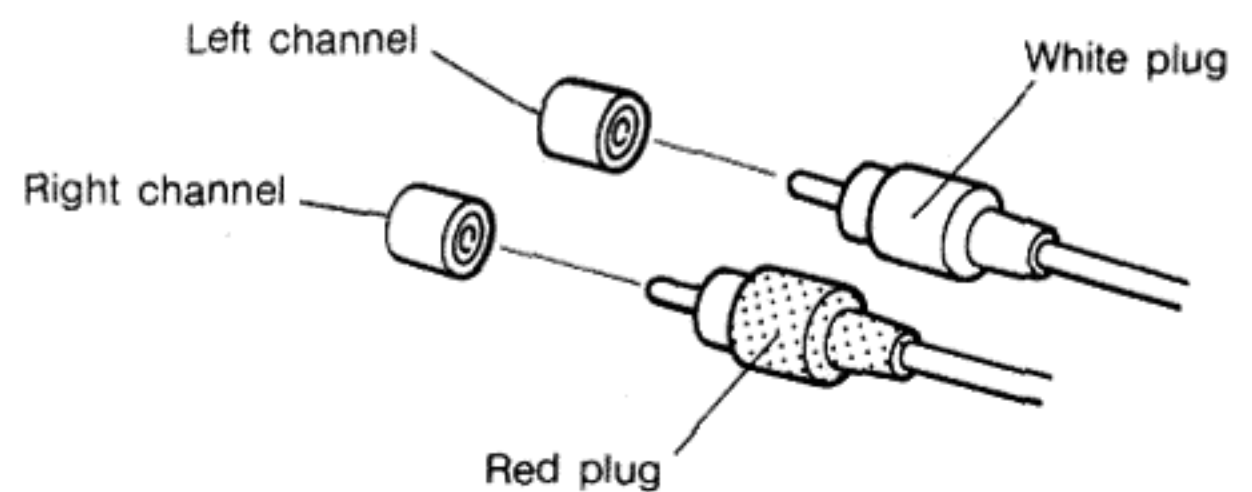

AC OUTLETS (SWITCHED)

Power supplied through these outlets is turned on and off by the amplifier's POWER switch. Total electrical power consumption of connected equipment should not exceed 200W.

AC OUTLET (UNSWITCHED)

Power flows continually to this outlet, regardless of whether the amplifier is switched ON or OFF. Electrical power consumption of the connected equipment should not exceed 100 W.

The equipment should be disconnected by removing the mains plug from the wall socket when not in regular use, e.g. when on vacation.

NOTE:

Do not connect appliances with high power consumption such as heaters, irons, or television sets to the AC OUTLETS in order to avoid overheating or fire risk. This can cause the amplifier to malfunction.

Fig. 1

FRONT PANEL

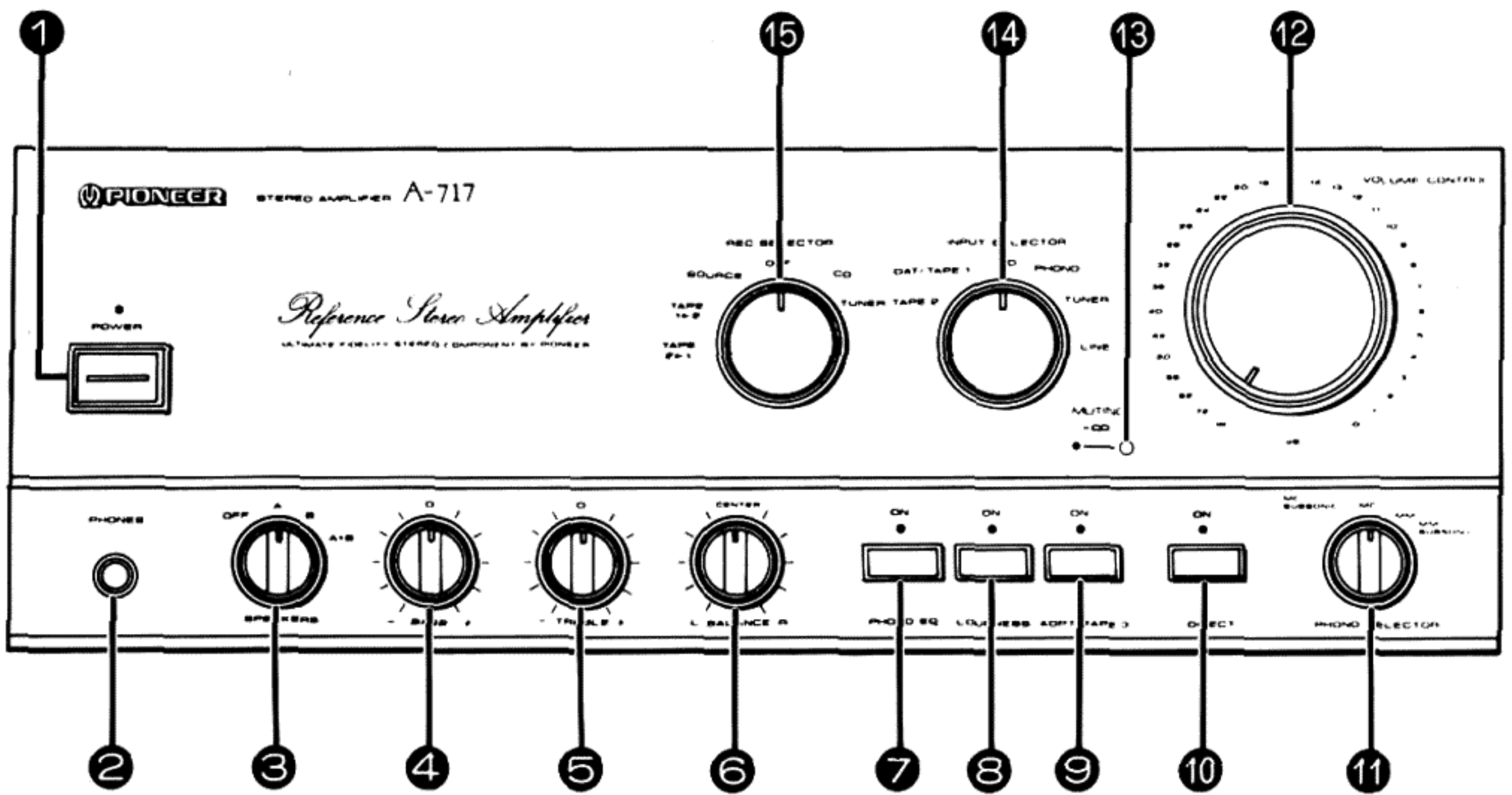

PANEL FACILITIES

Fig. 1

① POWER switch/indicator

Press to turn power to the unit ON and OFF.

② PHONES jack

When using headphones, insert the plug into this jack.

③ SPEAKERS selector switch

Use this switch to listen to the speaker systems connected to the SPEAKERS terminals.

OFF:

Released position: No sound is heard from the speaker system. Set to this position when listening with headphones.

A:

For reproduction of sound with the speaker systems connected to the SPEAKERS A terminals.

B:

For reproduction of sound with the speaker systems connected to the SPEAKERS B terminals.

A + B:

For reproduction of sound with the speaker systems connected to SPEAKERS A and B terminals.

④ BASS tone control

Use to adjust the low-frequency tone. The center position is the flat (normal) position. When turned to the right, low-frequency tones are emphasized; when turned to the left, low-frequency tones are de-emphasized.

NOTE:

This function does not operate when the DIRECT switch is in the ON position.

⑤ TREBLE tone control

Use to adjust the high-frequency tone. The center position is the flat (normal) position. When turned to the right, high-frequency tones are emphasized; when turned to the left, high-frequency tones are de-emphasized.

NOTE:

This function does not operate when the DIRECT switch is in the ON position.

⑥ BALANCE control

Should normally be left in the center position. Adjust balance if the sound is louder from one of the speakers. If the right side is louder, turn toward the LEFT position and if the left side is louder turn toward the RIGHT position.

NOTE:

This function does not operate when the DIRECT switch is in the ON position.

⑦ PHONO EQ switch/indicator

When not using a phono input, turn the phono equalizer power circuit off in order to prevent it from collecting noise during playback of other sources.

ON:

The indicator lights: Always set to this position when using a phono input. Immediately after turning ON, audio signal will be muted for several seconds until circuit operation becomes stable.

OFF:

The indicator goes off: Set to this position when not using a phono input.

⑧ LOUDNESS switch/indicator

Use when listening at low value levels.

ON:

The indicator lights: Boosts low and high frequencies to give added punch to playback even at low volume.

OFF:

The indicator goes off: Should normally be left in this position.

NOTE:

This switch does not operate when the DIRECT switch is in the ON position.

⑨ ADPT 1/TAPE 3 switch/indicator

Use this switch to listen to tape playback, or to listen to the sounds being recorded during tape recording.

ON:

The indicator lights: Press when listening to the playback sound of the tape deck or the adaptor connected to the ADPT 1/TAPE 3 PLAY terminals, or to monitor the sound being recorded on the tape deck connected to the ADPT 1/TAPE 3 REC terminals.

OFF:

The indicator goes off: Normally leave the switch in this position.

NOTE:

When the DIRECT switch is set to ON, this function does not operate and no signal is output at the ADPT 1/TAPE 3 REC terminals.

⑩ DIRECT switch/indicator

Use this switch/indicator when you do not wish to pass the output from input terminal equipment through the various frequency adjusting circuits and adaptor terminals (ADPT 1/TAPE 3, ADPT 2, BASS, TREBLE, BALANCE, LOUDNESS).

ON:

When the switch is in this position, the indicator lights and the signals input from the input terminals are reproduced without passing through the various frequency adjusting circuits. This results in flat, pure sound which is a more faithful reproduction of the input source.

OFF:

When the switch is in this position, the indicator goes out and the signal passes through the various frequency adjusting circuits.

PANEL FACILITIES

11 PHONO SELECTOR switch

Set in accordance with the type of cartridge used in your record turntable.

MM:

Set to this position when using a moving magnet cartridge, or a moving coil cartridge with high output of 1 mV or more.

MC:

Set to this position when using a moving coil cartridge.

MM SUBSONIC/MC SUBSONIC:

Subsonic filter for moving coil or moving magnet cartridges to cut ultralow frequency noise less than 7 Hz generated when playing a warped record.

When using a high-output moving coil cartridge, set this switch to MM or MM SUBSONIC.

12 VOLUME CONTROL

Use to adjust volume level.

NOTE:

This unit is equipped with a circuit that attenuates the effect of tone and loudness controls as volume is turned up.

13 MUTING switch/indicator

Use to temporarily cut sound volume.

ON:

The indicator lights: The sound volume will be cut off.

OFF:

The indicator goes off: The sound will return to its previous volume.

14 INPUT SELECTOR switch

Use to select playback source.

LINE:

Set to this position when listening to the programs from a component connected to the LINE terminals.

TUNER:

Set to this position when listening to AM or FM broadcasts with a tuner.

PHONO:

Set to this position when listening to record playback on a turntable.

CD:

Set to this position when listening to a compact disc playback with a CD player.

DAT/TAPE 1:

For playback with a tape deck or digital audio tape deck connected to the DAT/TAPE 1 terminals.

TAPE 2:

For playback with a tape deck connected to the TAPE 2 terminals.

15 REC SELECTOR switch

Switch to select recording signal. When set at other than SOURCE or OFF position, signals of other equipment can be recorded during playback on the equipment selected by INPUT SELECTOR switch.

TUNER:

To record the equipment of TUNER terminals.

CD:

To record the equipment of CD terminals.

OFF:

In this position, nothing from the REC terminals of DAT/TAPE 1 and TAPE 2 will be output. Select it when not recording; the tape deck will be disconnected, improving sound quality.

SOURCE:

To record the equipment selected by INPUT SELECTOR switch.

TAPE:

1 ► 2 — To record (copy) from the tape deck of DAT/TAPE 1 terminals, over to the tape deck of TAPE 2 terminals.

2 ► 1 — To record (copy) from the tape deck of TAPE 2 terminals, over to the tape deck of DAT/TAPE 1 terminals.

NOTE:

The REC SELECTOR switch has no effect on the ADPT 1/TAPE 3 terminals recording output.

OPERATIONS

BEFORE BEGINNING OPERATIONS

Set the controls and switches as follows: See Fig. 1.

1. Set the POWER switch to ON. ①
2. Set the SPEAKERS switch to A, B or A + B. ③
3. Set the BALANCE control to the center position. ⑥
4. Set the ADPT 1/TAPE 3 switch to OFF. ⑨
5. Set the DIRECT switch to OFF. ⑩

PLAYBACK PROCEDURES

1. Set the INPUT SELECTOR or ADPT 1/TAPE 3 switch. Use to select playback source.
 - When listening to programs from equipment connected to the LINE terminals: Set to [LINE].
 - When listening to an AM/FM broadcast: Set to [TUNER].
 - When listening to a record: Set to [PHONO]. PHONO EQ switch to ON. Set PHONO SELECTOR switch to MM (MM SUBSONIC) or MC (MC SUBSONIC) according to the type of cartridge being used.
 - When listening to a compact disc: Set to [CD].
 - When listening to a tape: Set to [DAT/TAPE 1], [TAPE 2] or [ADPT 1/TAPE 3].
2. Operate equipment to begin playback.
3. Adjust playback volume with the VOLUME CONTROL on this unit.

RECORDING TAPES:

1. Select the recording equipment with REC SELECTOR switch.
 - When set to the SOURCE position, the signals from the device connected to the selected input terminals are recorded. (To record signals from the device connected to the PHONO or LINE terminals, set the REC SELECTOR switch to SOURCE and set the INPUT SELECTOR switch to PHONO or LINE.) When record the signal from PHONO terminal, set PHONO EQ switch to ON position.
 - Recording is impossible with the switch set to OFF.

NOTE:

When this switch is set at other than SOURCE position, the equipment selected by REC SELECTOR switch can be recorded, irrespective of the settings of INPUT SELECTOR and DIRECT switches.

2. When using the tape deck connected to the ADPT 1/TAPE 3 terminals for recording.
 - The source selected with the INPUT SELECTOR will be recorded, regardless of the REC SELECTOR position. However, recording will not be possible when the DIRECT switch is ON.
3. Begin recording by operating the recording equipment and tape deck.
 - Refer to the operating instructions for your tape deck for proper operating procedures.

MONITORING WHILE RECORDING

On a 3-head tape deck, sound can be concurrently heard while recording on tape. This operation of checking the sound quality and recording level is called "monitoring". At the time of monitoring, set the INPUT SELECTOR switch of this equipment in the following way, to match the tape deck on which recording is being done.

- When recording on the tape deck of DAT/TAPE 1 terminals: Set to DAT/TAPE 1.
- When recording on the tape deck of TAPE 2 terminals: Set to TAPE 2.
- When recording on the tape deck of ADPT 1/TAPE 3 terminals: ADPT 1/TAPE 3 switch to ON.

COPYING TAPES:

When two decks (or a double cassette deck) are used, you can record the sounds from one deck onto the other.

Application examples:

- To make a tape copy with contents identical to the original tape.
- To edit a recording of an FM broadcast in order to cut out unwanted commercials, recording only desired material onto another tape.

When using two tape decks

1. Load tapes for playback (pre-recorded tape) and recording into the respective tape decks.
2. Select the tape deck to be copied with REC SELECTOR switch.
 - When copying from the tape deck of DAT/TAPE 1 terminals, to the tape deck of TAPE 2 terminals: Set to 1 ► 2.
 - When copying from the tape deck of TAPE 2 terminals, to the tape deck of DAT/TAPE 1 terminals: Set to 2 ► 1.

NOTE:

The tape selected with REC SELECTOR switch can be copied, regardless of the settings of INPUT SELECTOR and DIRECT switches.

3. Operate the tape decks to begin copying. Set the tape deck with the original (playback) tape to the playback mode, and set the tape deck with the tape to the recording mode.

Playback using graphic equalizer

- As to A-717, it can deal with playback of all sources by connecting the graphic equalizer to the ADPT 2 terminals. However, it is not possible when the DIRECT switch is ON.

NOTE:

Remove the shorting bars before connecting to these terminals. Always keep the bars inserted while the terminals are not in use, and take care not to lose them.

TROUBLESHOOTING

Incorrect operations are often mistaken for trouble or malfunctions. If you think that there is something wrong with this component, check the points below. Sometimes the trouble may lie in another component. Investigate the other components and electrical appliances being used. If the trouble cannot be rectified even after exercising the checks listed below, ask your nearest PIONEER authorized service center or your dealer to carry out repair work.

Symptom	Probable Cause	Remedy
No power supplied to unit	<ul style="list-style-type: none"> Power plug is disconnected from outlet. The component's power plug has been plugged into another component's power outlet (e.g. timer, etc.), but power to that unit is disconnected. 	<ul style="list-style-type: none"> Insert plug securely in outlet. Turn on power to other component.
No sound	<ul style="list-style-type: none"> Connecting cords are disconnected from terminals, or connected incorrectly. Terminals, or connecting cords' pin plugs are dirty. The INPUT SELECTOR or ADPT 1/TAPE 3 switch selected do not match the component being played back. Operation of other components is incorrect. The SPEAKERS selector switch is set to "OFF". The PHONO EQ switch is "OFF" position. 	<ul style="list-style-type: none"> Connect securely. Clean terminals and plugs. Set switches correctly (PHONO, TUNER, CD, LINE, DAT/TAPE 1, TAPE 2). Set the ADPT 1/TAPE 3 to OFF. Consult the operating instructions for the other components. Set the switch to "A", "B" or "A + B". Set PHONO EQ switch to "ON" position.
No sound from one speaker	<ul style="list-style-type: none"> Connecting cords or speaker cords are disconnected on that side. BALANCE control has been adjusted to one side. 	<ul style="list-style-type: none"> Connect securely. Adjust BALANCE control to center position.
Can't record tapes	<ul style="list-style-type: none"> The position of the REC SELECTOR switch is incorrect. Connections are incorrect. Operation of tape deck is incorrect. 	<ul style="list-style-type: none"> Set switch correctly (See section "RECORDING TAPES"). Re-connect properly. Consult the operating instructions for the tape deck.
Can't perform tape copying	<ul style="list-style-type: none"> The position of the REC SELECTOR switch is incorrect. Operation of tape decks is incorrect. 	<ul style="list-style-type: none"> Set switch correctly (See section "COPYING TAPES"). Consult the operating instructions for the tape decks.

SPECIFICATIONS

Continuous Average Power Output is 100 Watts* per channel, min., at 8 ohms from 20 Hertz to 20,000 Hertz, with no more than 0,003% total harmonic distortion.

*Measured pursuant to the Federal Trade Commission's Trade Regulation rules on Power Output Claims for Amplifiers.

FTC continuous power output (both channels driven)*	
20 Hz to 20 kHz, T.H.D. 0.003%, 8Ω	100W + 100W
20 Hz to 20 kHz, T.H.D. 0.005%, 4Ω	135W + 135W
Power bandwidth	
0.05%, 8Ω	4 Hz – 80 kHz
Damping factor	
(1 kHz/20 Hz to 20 kHz), 8Ω	200/70
Total harmonic distortion*	
20 Hz to 20 kHz, 100W, 8Ω	0.003%
20 Hz to 20 kHz, 135W, 4Ω	0.005%
Inter-modulation distortion (at rated output)	0.003%
Input sensitivity/impedance	
PHONO (MM)	2.5 mV/50 kΩ
PHONO (MC)	0.2 mV/100Ω
CD, TUNER, LINE, TAPE	150 mV/50 kΩ
PHONO overload level	
1 kHz, T.H.D. 0.008% (MM/MC)	200 mV/19 mV
Output level/impedance	
TAPE REC, ADAPTOR OUTPUT	150 mV/2.2 kΩ
Frequency response	
PHONO (MM), 20 Hz to 20 kHz	±0.2 dB
PHONO (MC), 20 Hz to 20 kHz	±0.3 dB
CD, TUNER, LINE, TAPE 1 Hz to 150 kHz	+0 -3 dB
Tone control (volume control set at -40 dB position)	
BASS	±8 dB (100 Hz)
TREBLE	±8 dB (10 kHz)
Loudness contour (volume control set at -40 dB position)	
	+5 dB (100 Hz)/+3 dB (10 kHz)
Filter (SUBSONIC)	7 Hz (12 dB/oct)
Signal-to-Noise ratio (IHF short circuit, A network)	
PHONO (MM, 5 mV input/MC, 0.5 mV input)	95 dB/77 dB
CD, TUNER, LINE, TAPE	108 dB

Power Supply/Miscellaneous

Power requirements	AC 120V, 60 Hz
Power consumption	500W (650 VA)
Dimensions	420(W) × 435(D) × 162(H) mm 16-1/2(W) × 17-1/8(D) × 6-3/8(H) in
Weight	19 kg (41 lb 14 oz)

Accessories

- Operating instructions 1
- Specifications and design subject to possible modification without notice due to improvements.
 - *Measured by Audio Spectrum Analyzer.

PIONEER ELECTRONIC CORPORATION 4-1, Meguro 1-Chome, Meguro-ku, Tokyo 153, Japan
PIONEER ELECTRONICS [USA] INC. 2265 East 220th Street Long Beach, California 90810 U.S.A.
P.O. BOX 1720 Long Beach, California 90801-1720 U.S.A.
PIONEER ELECTRONICS OF CANADA, INC. 505 Cochrane Drive, Markham, Ontario L3R 8E3 Canada
PIONEER ELECTRONIC [EUROPE] N.V. Keetberglaan 1, 2740 Beveren, Belgium TEL: 03/775-28-08
PIONEER ELECTRONICS AUSTRALIA PTY. LTD. 178-184 Boundary Road, Braeside, Victoria 3195, Australia TEL: [03] 580-9911