

## ■ Measurement instruments required for adjustment

- 1 Low frequency oscillator  
This oscillator should have a capacity to output 0dBs to 600 at an oscillation frequency of 50Hz-20KHz
- 2 Electronic voltmeter
- 3 Distortion meter
- 4 Frequency counter
- 5 Wow & flutter meter
- 6 Test tape  
TCC-112 : Tape speed and running unevenness (3KHz)  
TCC-140 : Reference level (1KHz)  
TCC-182A : Head angle (8KHz) , playback frequency characteristics (1KHz) and dubbing frequency characteristics (125Hz and 8KHz)  
Because of frequency - mixed tape with 63 , 1 , 10 and 14KHz (250nWb/m -24dB) , use this tape together with a filter .
- 7 Black tape  
TYPE I : AC - 225  
TYPE II : AC - 514
- 8 Torque gauge : For play and back tension  
FWD(TW2111A) , REV(TW2121a) and FF/REW(TW2231A)

## ■ Measurement conditions

Power supply voltage ----- AC 120V (60Hz)/230V (50Hz)  
Reference output ----- Speaker : 1.414V/4  
Headphone : 0.18V/32  
Reference frequency and ----- 1KHz , AUX : 450~500mV  
input level  
Input for confirming recording and ----- AUX : -28dBs  
playback characteristics  
Measurement output terminal --- Speaker SPJ601 OR SPJ603  
\* Load resistance ----- 4

## ■ Radio Input signal

AM frequency ----- 400Hz  
AM modulation ----- 30%  
FM frequency ----- 1 KHz  
FM frequency deviation ----- 22.5KHz

## ● Tuner section

Voltage applied to tuner ----- +B:DC 4.5V

VT:DC 12V

Reference measurement ----- 1.414V/4

output

Input positions ----- AM : Standard loop antenna

FM : FMANT (hot) and D102 (GND)

## ● Standard measurement position of volume

Active hoper EQ -----FLAT

Up and down adjustment of volume ----- Vol : 31

## Precautions for measurement

- 1 Apply 47PF and 33 Kohm to the IF sweeper output side and 0.1UF and 100 Kohm in series to the sweeper input side .
- 2 The IF sweeper output level should be made as low as possible within the adjustable range .
- 3 Since the IF sweeper is a fixed device , there is no need to adjust this sweeper .
- 4 Since a ceramic oscillator is used , there is no need to perform any MIX adjustment .
- 5 Since a fixed coil is used , there is no need to adjust the FM tracking .
- 6 The input and output earth systems are separated . In case of simultaneously measuring the voltage in both of the input and output systems with an electronic voltmeter for two channels , therefore , the earth should be connected particularly carefully .
- 7 In the case of BTL connection amp. , the minus terminal of speaker is not for earthing . Therefore , be sure not to connect any other earth terminal to this terminal . This system is of an BTL system .
- 8 For connecting a dummy resistor when measuring the output , use the wire with a greater code size .
- 9 Whenever any mixed tape is used , use the band pass filter (DV-12V)

**1 HEAD AZIMUTH ADJUSTMET**

- (1) Load the test tape TCC-182A 8KHz for azimuth adjustment.
- (2) Press the PLAY button.
- (3) Use a cross-tip screwdriver to turn the screw for azimuth adjustment so that the left and right output are maximized
- (4) Press the STOP button
- (5) After completion of the adjustment. Use thread lock(TB-1401B) to secure the azimuth-adjustment screw.

**2 AC BIAS FREQUENCY ADJUSTMENTS**

- (1) Connect frequency counter to SW301(PIN1);
- (2) R/P swith in recording state;
- (3) Adjusting T301 use a plastic screwdriver, AC bias frepuency;60+-1KHZ..

**3 TAPE SPEED ADJUSTMENT**

- (1) Insert the test tape(MTT-111N,3,000 HZ)
- (2) Press the PLAY button.
- (3) Use a flat-tip screwdriver to turn the VR 301.

adjust VR501 so that the frequency counter become 3,000Hz

TAPE HEAD AND SPEED ADJUSTMENT DIAGRAM

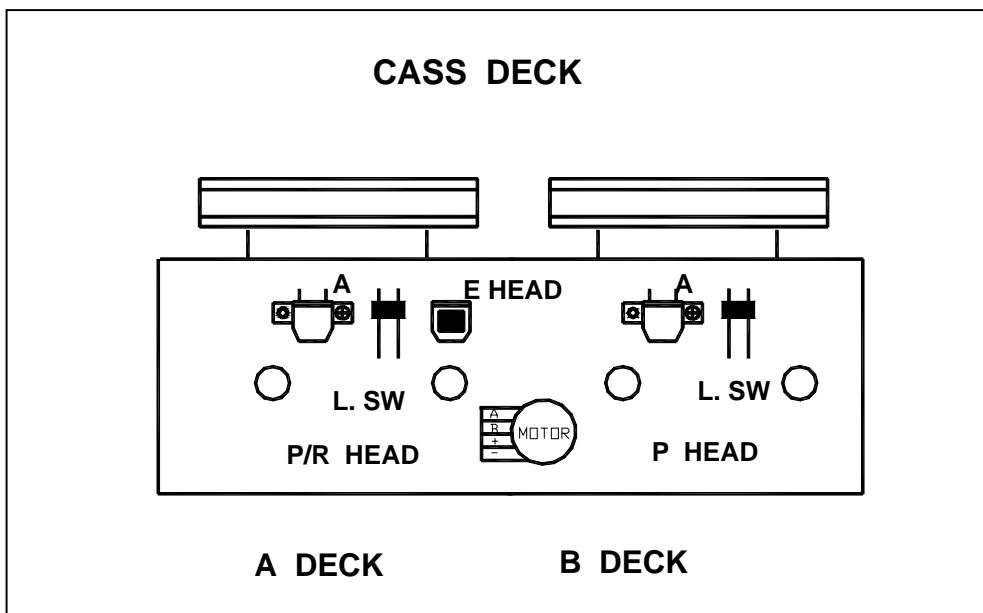

Items	Measurement conditions	Measrrnment method	Standard Values	Adjusting] positions
Confirmation of head angle	Test tape :TA-182A(8KHz) Measurement output terminal :Speaker terminal Sperker R (Load resistance:4 ) :Headphone terminal	1 Playback the test tape TCC-182A (8KHz) 2 With the recording & playback mechanism, adjust the head azimuth screw so that the left and right output levers become maximum, After adjustment, lock the head azimuth at least by half turn.	Maximum output	Adjust the head azimuth screw only when the head has been changed
Confirmation of tape speed	Test tape :TCC-112(3000Hz) Measurement output terminal :Headphone terminal	Adjust VR301 so that the frequency counter reading becomes 3,010Hz +/-15Hz when playing back the test tape TCC-112 (3000Hz) with playback and recording mechanism after ending forward winding if the taoe.	Tape speed of deck :3,010Hz +/-15Hz	VR301

■ Reference Values for Confirmation Items

ITEMS	Measurement conditions	Measrrnment method	Standard Values	Adjusting] positions
Wow & flutter	Test tape :TCC-112(3000Hz) Measurement outut terminal :Headphone terminal	When the test tape TCC-112 (3000Hz) has been played back with the recording and playback mecganism at the beginning of forward winding, the frequency counter reading of wow & flutter should be 0.25% or less (WRMS).	0.25% or less (WRMS)	

■ Electrical Performance

ITEMS	Measurement conditions	Measrrnment method	Standard Values	Adjusting] positions
Adjustment of recording bias current (Reference Value)	* Mode:Forward or reverse mode * Recording mode * Test tape TDK-60 Measurement output terminal :Both recording and headphone terminals	1 With the recording and playback mechanism, load thd test tapes TDK-60 , and set the mechanism to the recording and pausing condition in advance . 2 After connecting 100 in series to the recorder head, measure the bias current with a valve voltmeter at both of the terminals	4.5 μ A +/-0.5 μ A	

Adjustment of recording and playback frequency characteristics	Reference frequency :1KHz and 8KHz (REF.: -20dB) Test tape TDK-60 Measurement input terminal : OSC IN	1 with the recording and playback mechanism, load the test tapes (TDK-60) and set the mechanism to the recording and pausing condition in advance 2 While repetitively inputting the reference frequency signal of 1KHz and 10KHz from OSC IN, record and playback the tape.	Output deviation between 1KHz and 8KHz : -1dB +/-2dB	
--	---	---	--	--

### ■ Reference Values for Electrical Function Confirmation Items

Items	Measurement conditions	Measurement method	Standard Values	Adjusting positions
Recording bias frequency	Forward or reverse · Test tape TDK-60 · Measurement terminal : BIAS TP on P.C. board	1 While changing over to and from BIAS 1 and 2, confirm that the frequency is changed 2 With the recording and playback mechanism, load the test tape. (TDK-60) , and set the mechanism to the recording and pausing condition in advance. 3 Confirm that the BIAS TP frequency on the P.C. board is 60KHz +/-1KHz	60KHz +/-1KHz	

# Flow of functional operation until TOC read

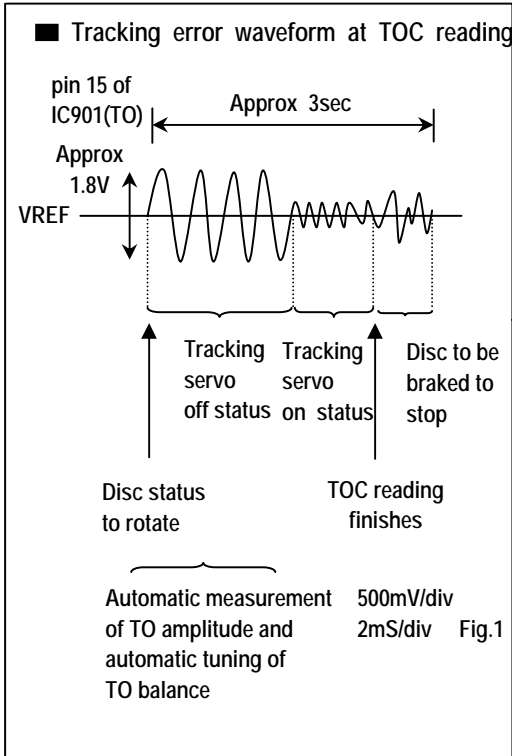
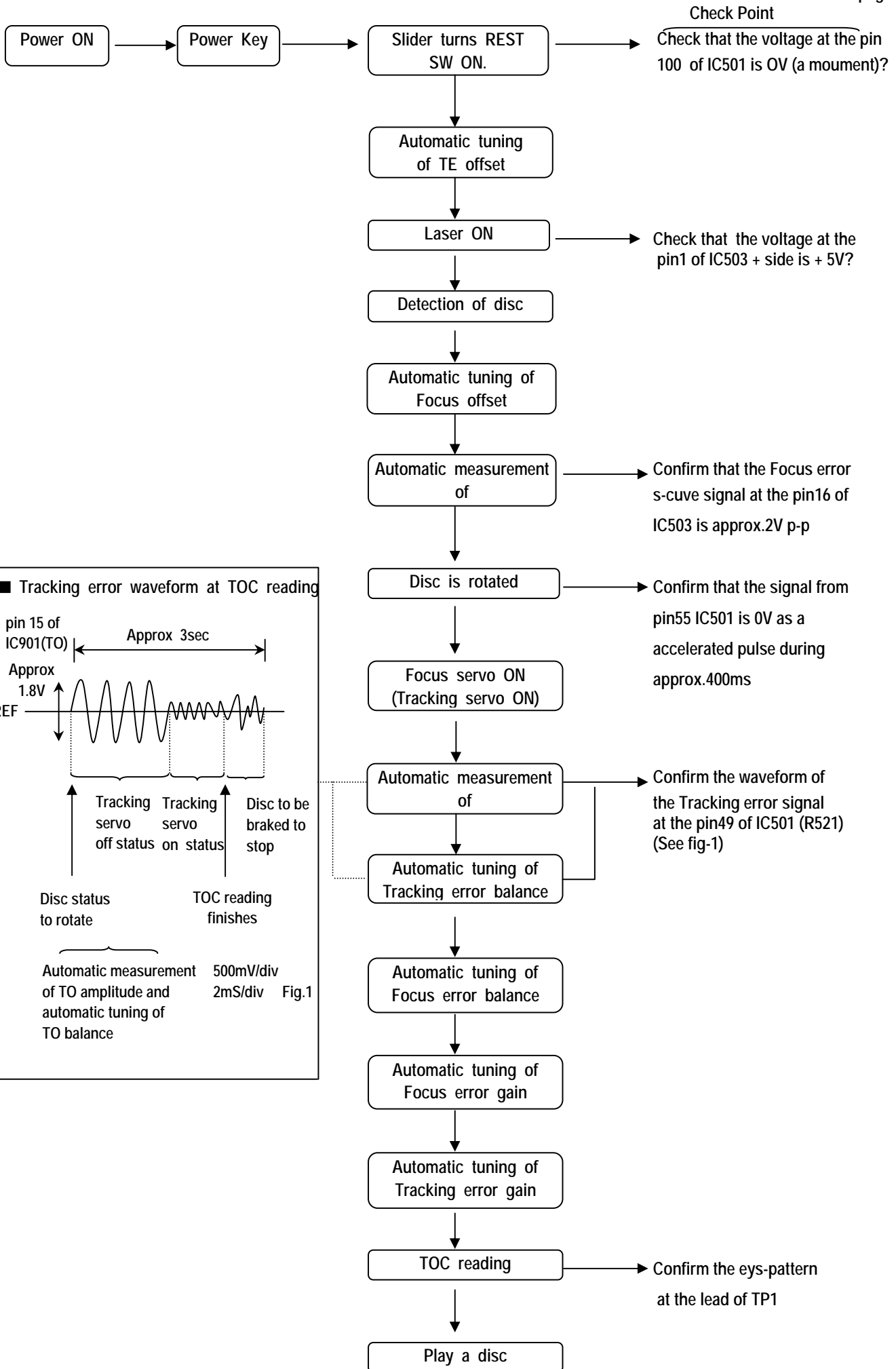

# TUNER ADJUSTMENTS

use a plastic screw driver for adjustments.

Adjust the intermediate frequency of AM and FM to the frequency of ceramic filter.

- Supply voltage : DC 12.0 V
- Speaker impedance : 4 OHMS
- Function switch : RADIO

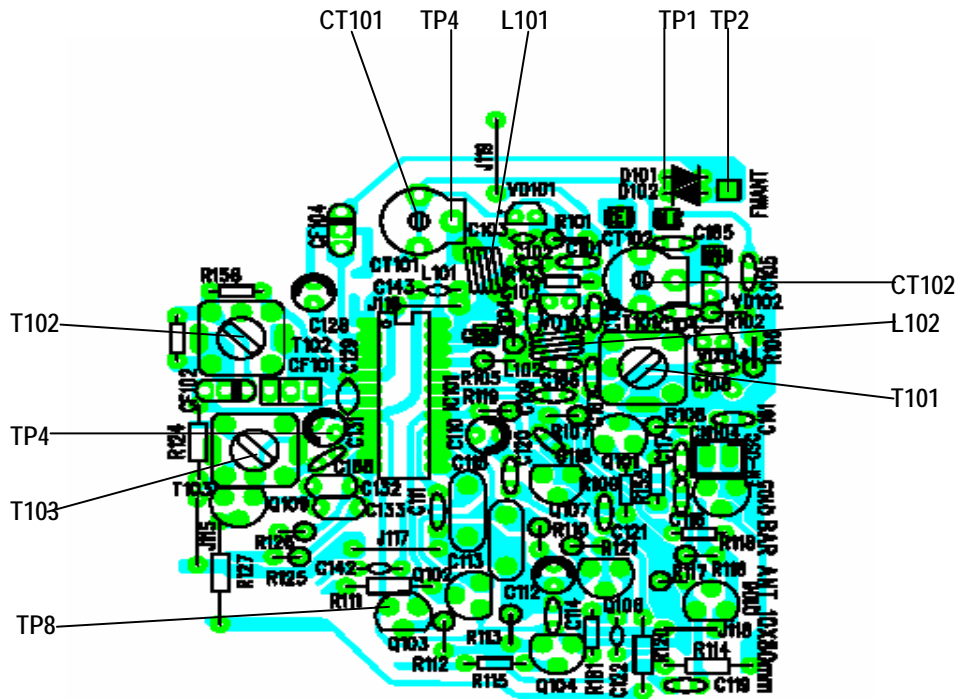

## a. AM Adjustment

BAND SELECT TO : MW

step	Adjusting circuit	Tuning Frequency	Input Connection		Output Connection		Adjustment parts	Oscilloscope and VTVM
			Measurement	input	Measurement	output		
1	IF (450KHz)	999KHz 1000 KHz	AM Sweep Generior	AM ANT	VTVM Oscilloscope	TP4(H) TP8(E)	T102	 (Non-adjustment)
2	Tuning Coverage	522~1620KHz	AM Signal	AM	Digital Voltmeter	TP4(H)	T101	Low END Confirm 1.8V +/-0.1V
3		520~1710KHz	Generior	ANT	Oscilloscope	TP8(E)		
4		603/600 KHz	AM Signal	AM	VTVM	TP4(H)	AM COIL	 Maximum
5		1404/1400 KHz	Generior	ANT	Oscilloscope	TP8(E)		

## b. FM Adjustment

BAND SELECT TO : FM

FM Dummy Antenna : 75 ohm unbalance

ste	Adjusting circuit	Tuning Frequency	Input Connection		Output Connection		Adjustment parts	Oscilloscope and VTVM
			Measurement	input	Measurement	output		
1	IF (10.7 MHz)	98.0 MHz	FM Sweep Generator	TP4(E) TP4(H)	Oscilloscope	TP4(H) TP8(E)	T103	 (Non-adjustment)
2	Tuning Coverage	87.5 MHz	FM Signal	FM ANT	Digital Voltmeter	TP4(H)	L102	Low END Confirm 1.8 +/-0.1V
3		108 MHz	Generator	TP1 (E) TP2(H)	Oscilloscope	TP8(E)		
4	Tracking	90.0 MHz	FM Signal	FM ANT	VTVM	TP4(H)	L101	 Maximum
5		106.0 MHz	Generator	TP1 (E) TP2(H)	Oscilloscope	TP8(E)		

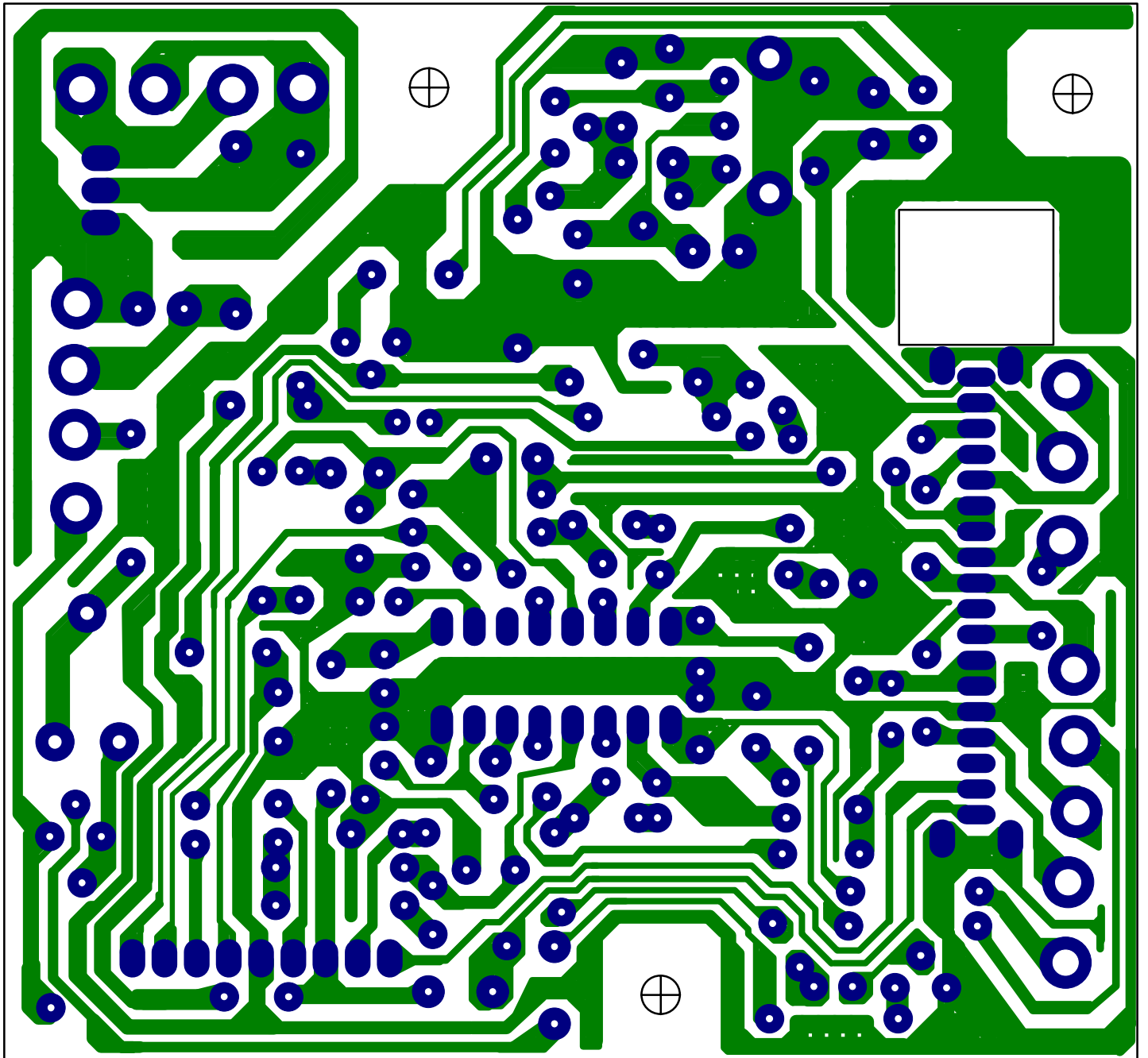

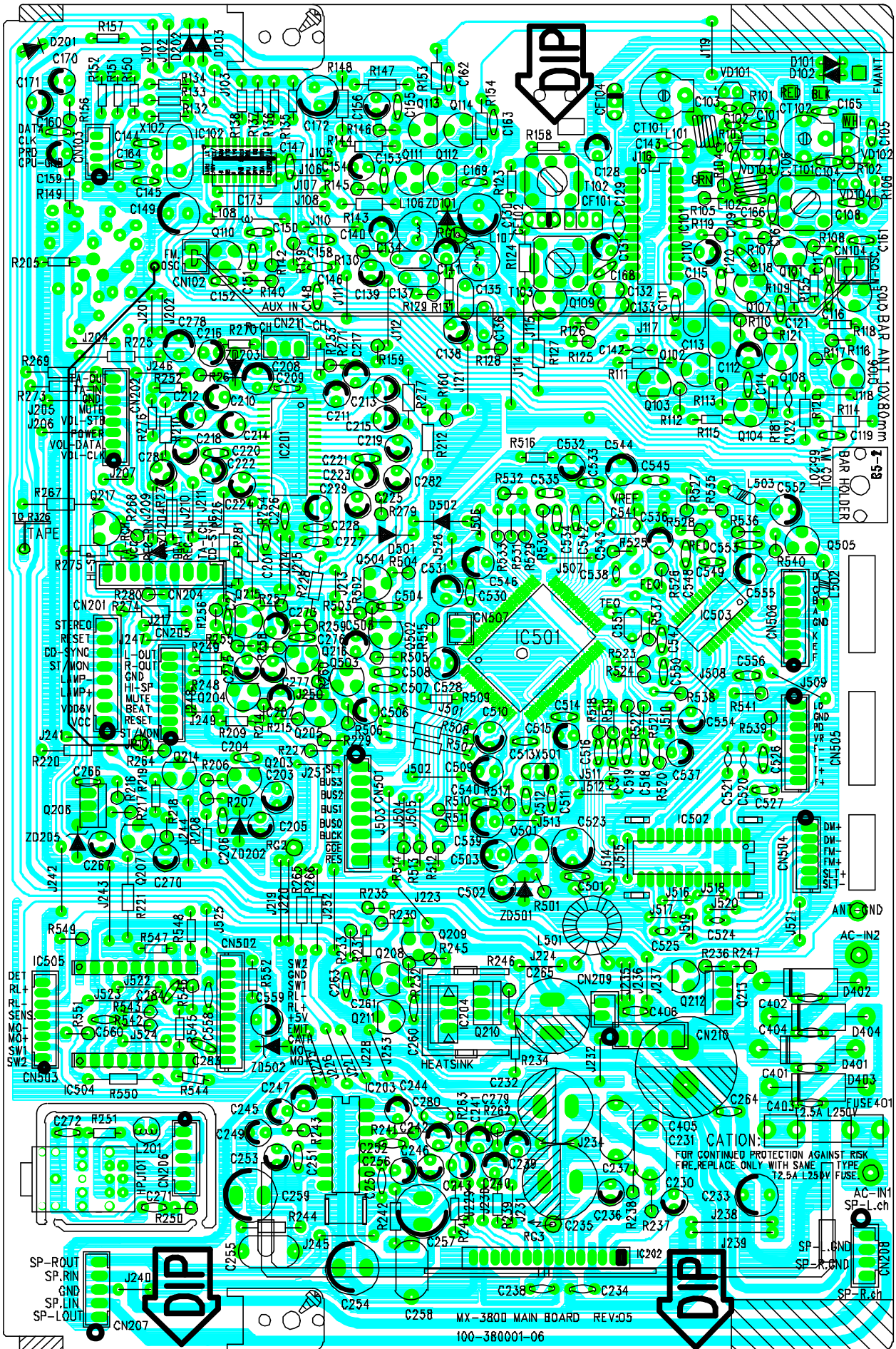

08/OCT/2002



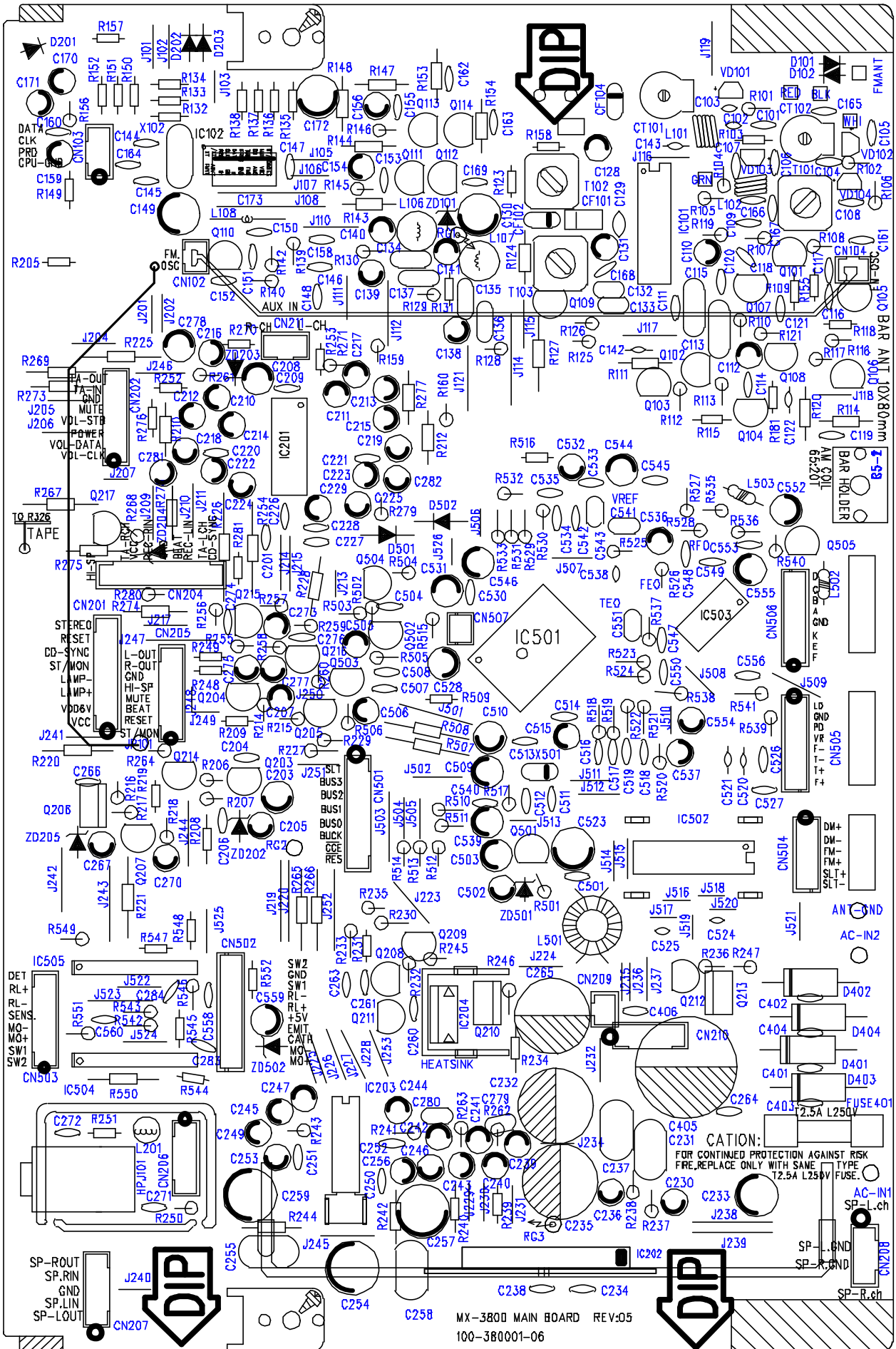

08/OCT/2002

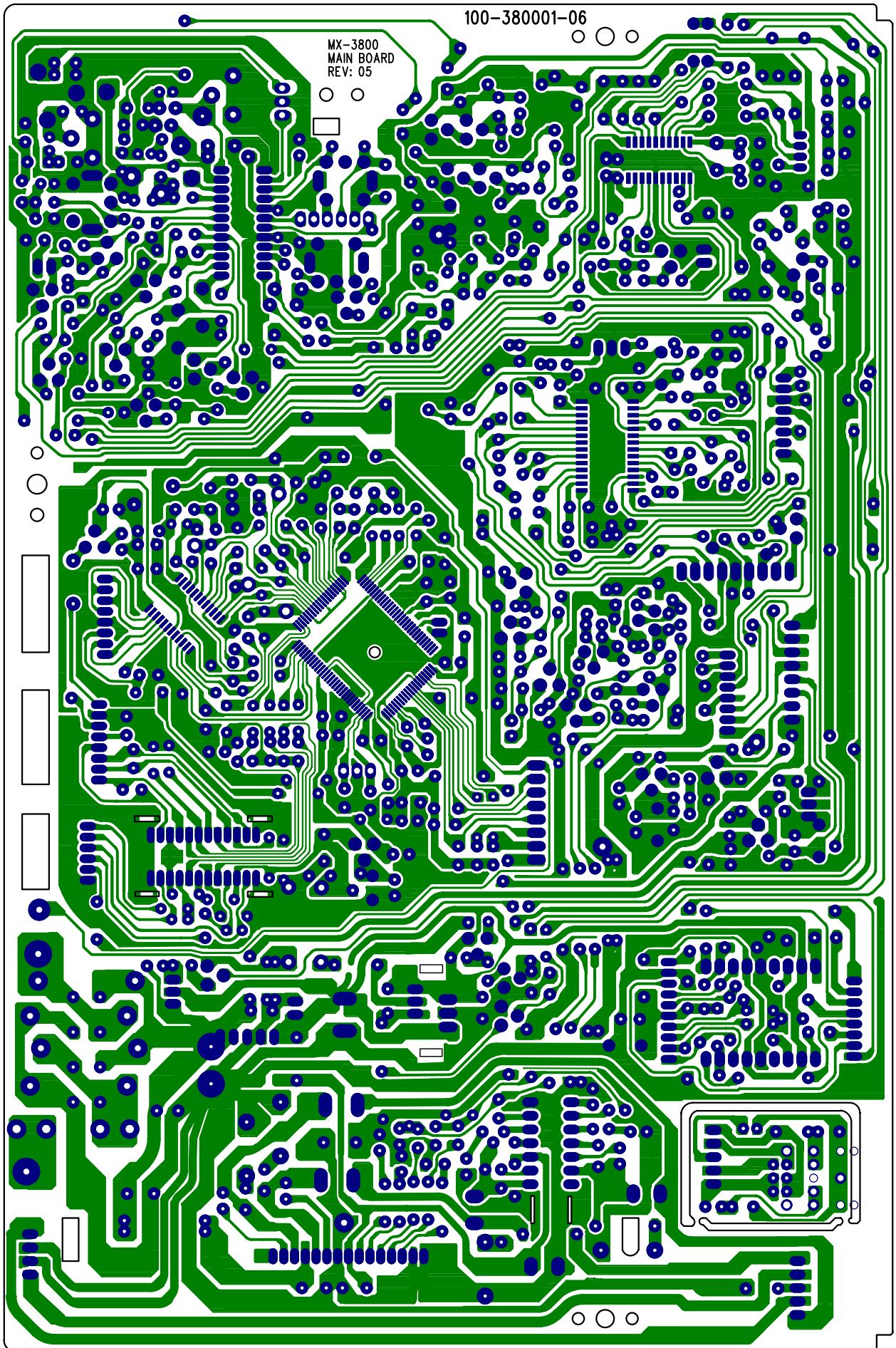

5005\T00\80

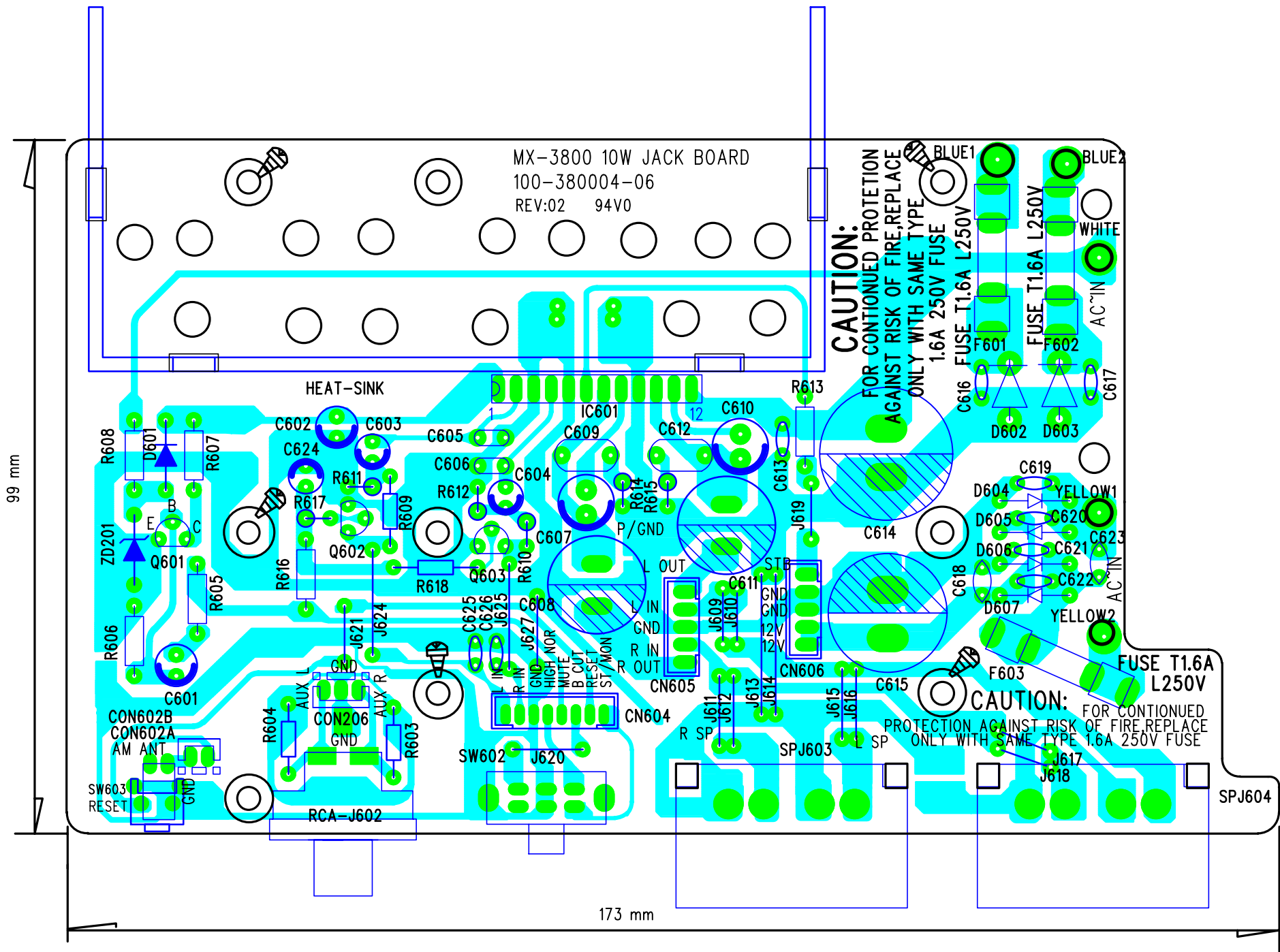

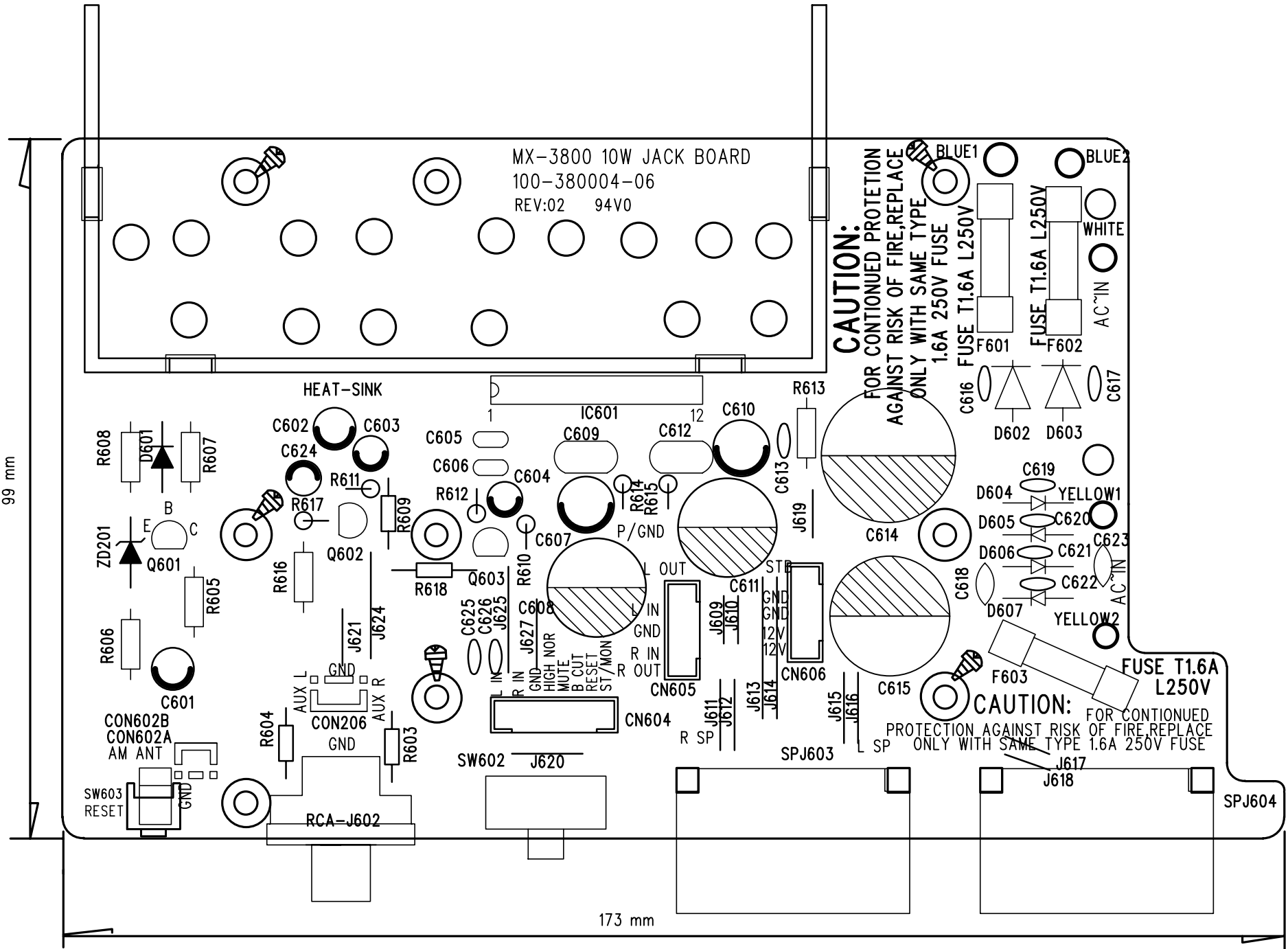

MX-3800 10W JACK BOARD  
 100-380004-06  
 REV:02 94V0

**CAUTION:**  
 FOR CONTIUNUED PROTECTION  
 AGAINST RISK OF FIRE,REPLACE  
 ONLY WITH SAME TYPE  
 1.6A 250V FUSE

BLUE1  
 BLUE2  
 WHITE  
 AC~IN  
 FUSE T1.6A L250V  
 F601  
 F602

**CAUTION:**  
 FOR CONTIUNUED PROTECTION  
 AGAINST RISK OF FIRE,REPLACE  
 ONLY WITH SAME TYPE  
 1.6A 250V FUSE

FUSE T1.6A  
 L250V  
**CAUTION:**  
 FOR CONTIUNUED PROTECTION  
 AGAINST RISK OF FIRE,REPLACE  
 ONLY WITH SAME TYPE 1.6A 250V FUSE

99 mm

173 mm

MX-3800 10W JACK BOARD  
100-380004-06  
REV:02 94V0

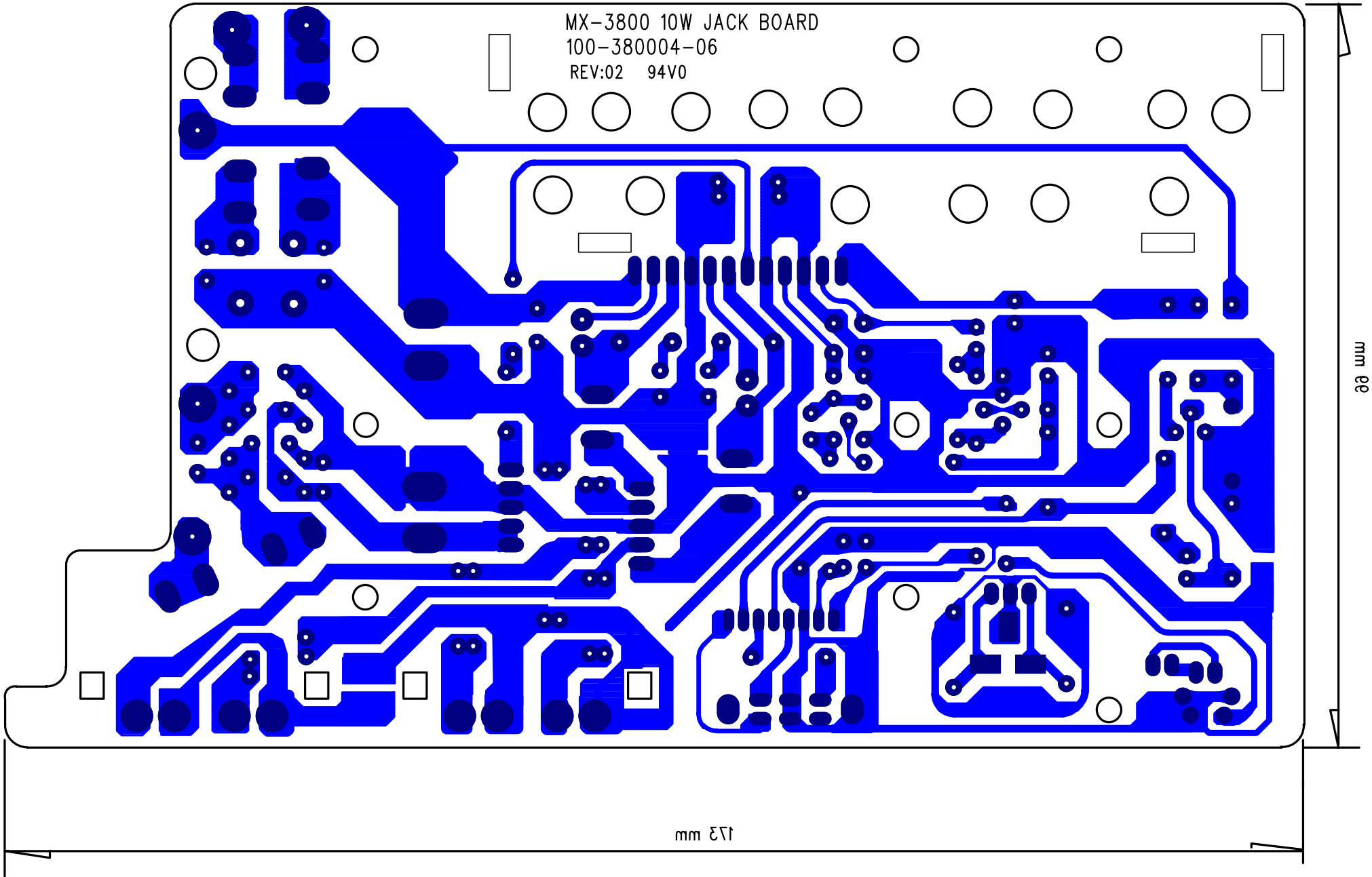

173 mm

88 mm



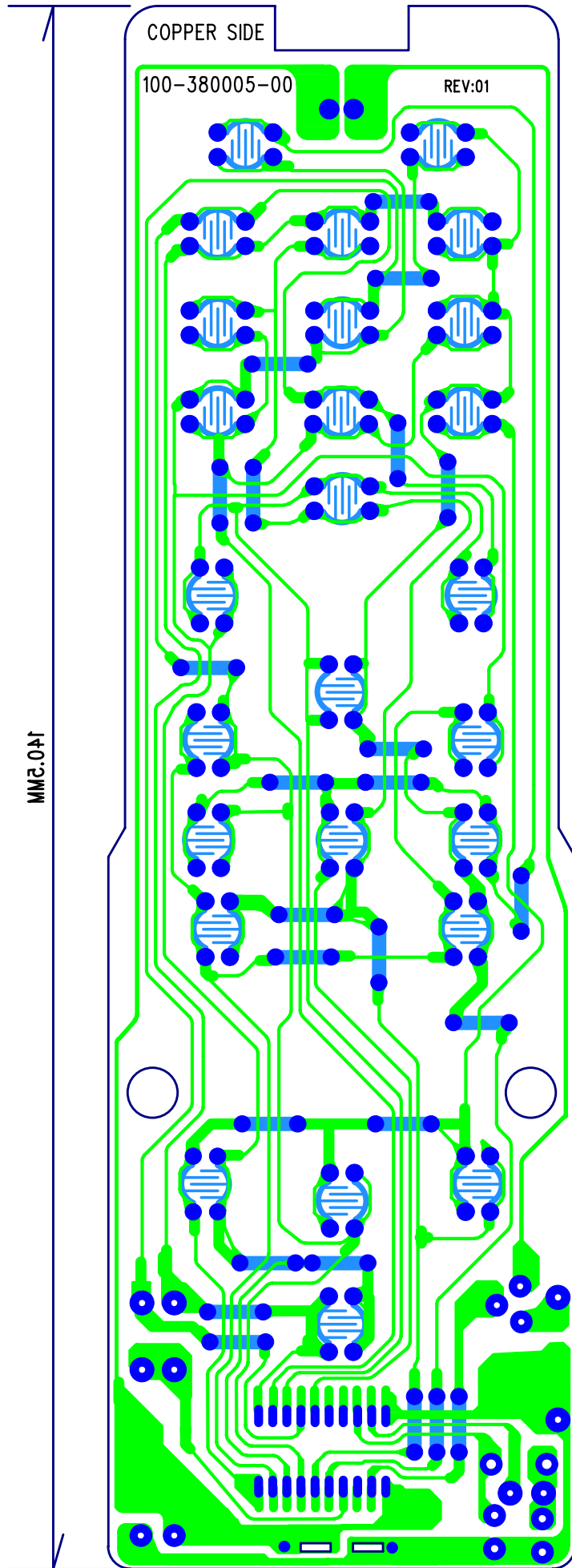

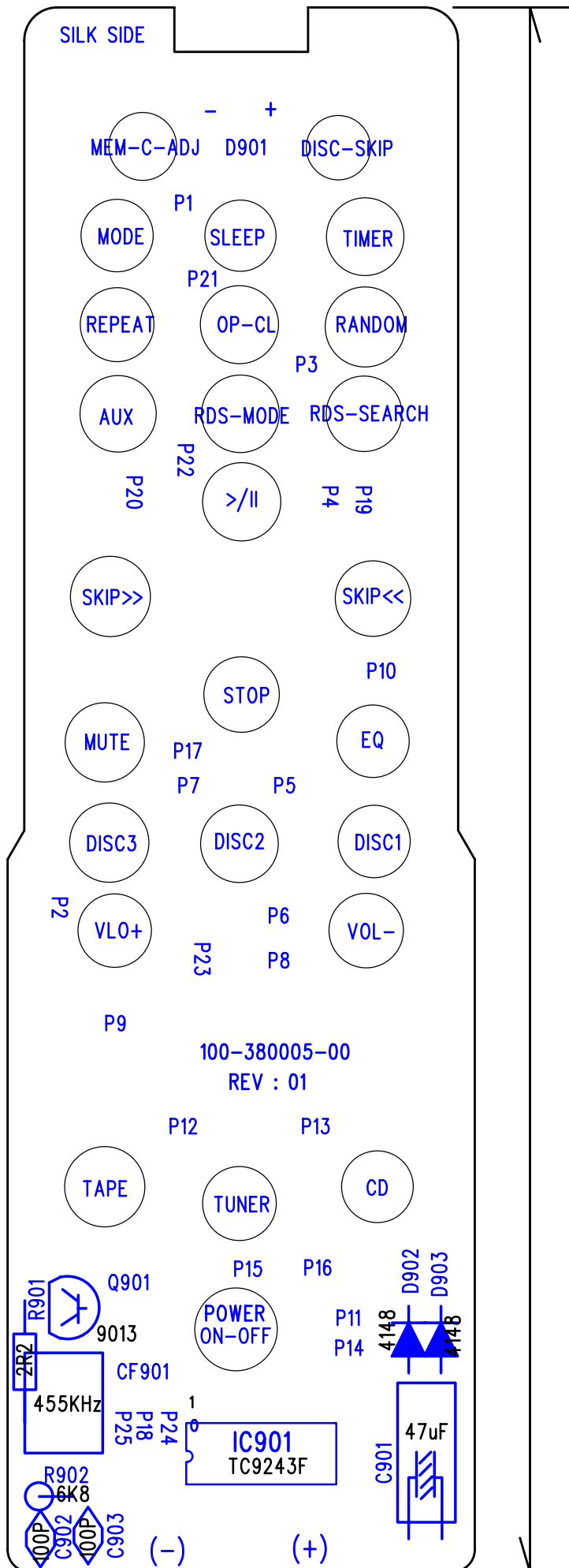





# COMPONENT SIDE

A1  
↑

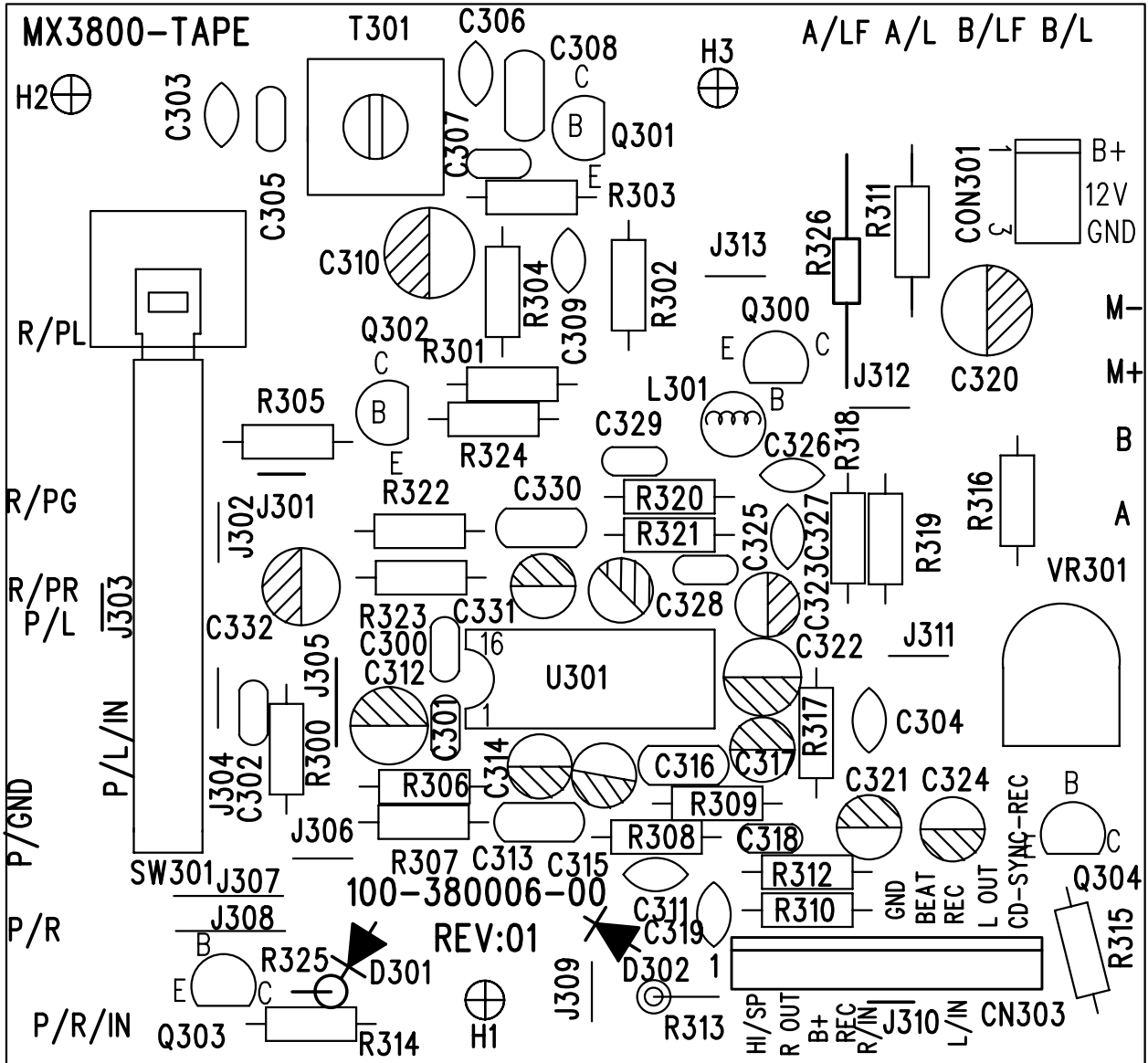

A2  
↓

←

→ A4

# MX-3800 10W WIRING DIAGRAM

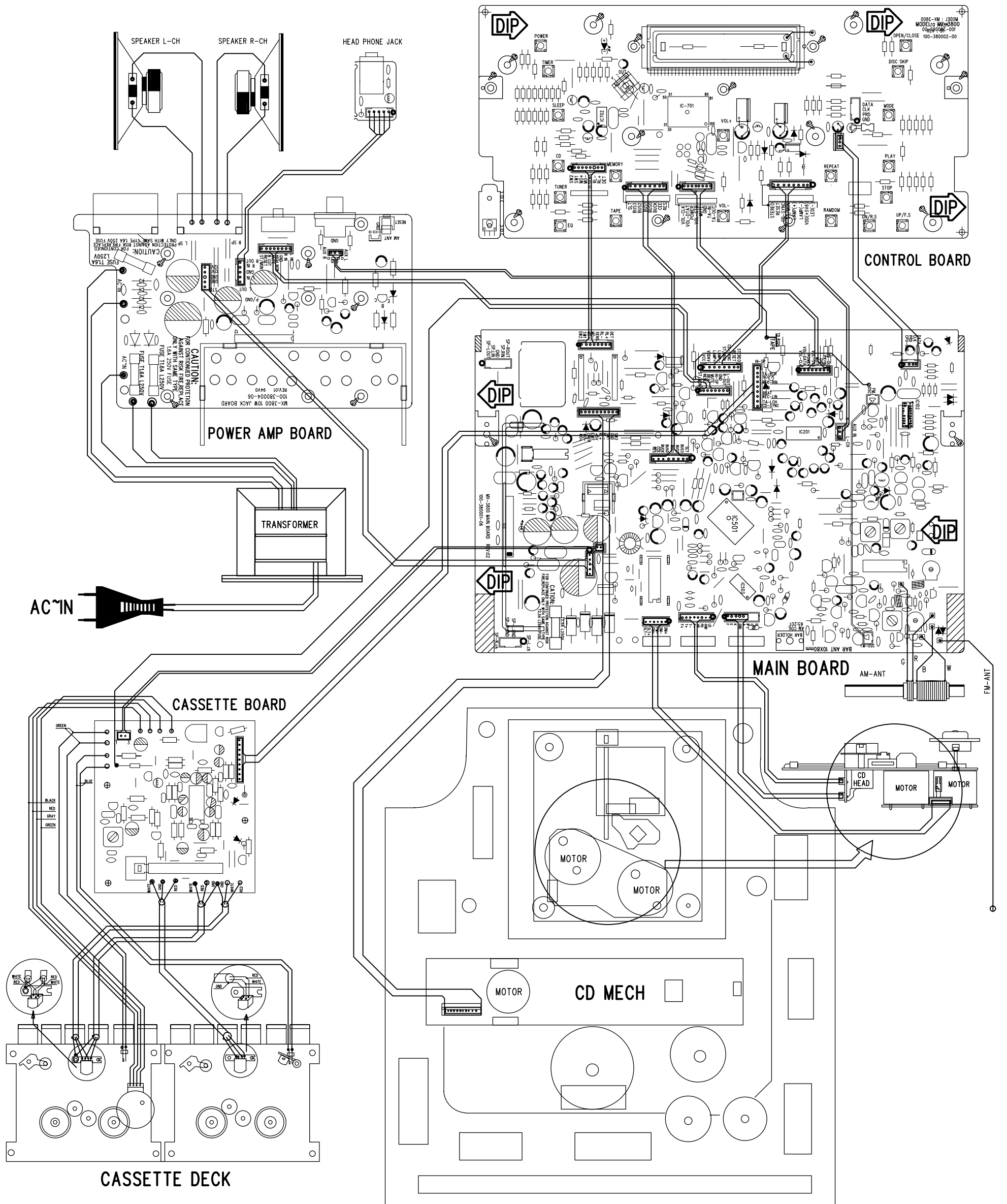

# KENLEX ELECTRONICS LTD.

24/F., NANYANG PLAZA, 57 HUNG TO ROAD,  
 KWUN TONG, KOWLOON, HONG KONG.  
 TEL: 27577368, 27577718 FAX: 27519212

## SPECIFICATION

AM SECTION

MODEL : MX-3800(10W)

DATE : 22/MAY/2002

TEST CONDITION : 400 Hz 30% MODULATION

REF. OUTPUT : 500 mW 4 Ohm

ITEM		UNIT	NORMAL	LIMIT	DATA
1. FREQUENCY RANGE	HIGH END	KHz	1620/1710	+/-3	
	LOW END	KHz	522/530	+/-3	
2. IF FREQUENCY		KHz	450	450 +/-3	
3. MAXIMUM SENSITIVITY	612/610 kHz	dB/M	54	60	
	999/1000 kHz	dB/M	54	60	
	1404/1400 kHz	dB/M	54	60	
4. SENSITIVITY FOR 20 dB S/N	612/610 kHz	dB/M	60	66	
	999/1000 kHz	dB/M	60	66	
	1404/1400 kHz	dB/M	60	66	
5. IF REJECTION	612/610 kHz	dB	42	35	
6. IMAGE REJECTION	1404/1400 kHz	dB	40	34	
7. AUTO STOP SENS.	999/1000 kHz	dB/M	64	70	
8. WHISTLE MODULATION	5 mV IN	%	7	12	
9. AGC EFFECT	999/1000 kHz	dB	38	32	
10. S/N RATIO 999/1000 kHz	5mV IN	dB	35	30	
11. T.H.D	999/1000 kHz	%	2	4	
12. FREQUENCY RESPONSE 999/1000 kHz	-6 dB	Hz	125-2500	150-2000	
13. MIN. VOL. HUM	999/1000 kHz	mV	2	3	
14. OSC FALL-OUT VOLTAGE AC	999/1000 KHz	V	-30%	-20%	
15. OVER LOAD THD AT REF O/P MOD80%	999/1000 KHz	%	3	6	

# KENLEX ELECTRONICS LTD.

24/F., NANYANG PLAZA, 57 HUNG TO ROAD,  
KWUN TONG, KOWLOON, HONG KONG.  
TEL: 27577368, 27577718 FAX: 27519212

## SPECIFICATION

FM SECTION

MODEL : MX-3800 (10W)

DATE : 22/MAY/2002

TEST CONDITION : 1 KHZ 22.5 KHZ DEV.(MONO)

REF. OUTPUT : 500 mW 4 Ohm

ITEM		UNIT	NORMAL	LIMIT	DATA
1. FREQUENCY RANGE	HIGH END	MHz	108.0	+/-0.1	
	LOW END	MHz	87.5	+/-0.1	
2. IF FREQUENCY		MHz	10.7	+/-0.1	
3. MAXIMUM SENSITIVITY	90.1 MHz	dB	16	20	
	98.1 MHz	dB	16	20	
	106.1 MHz	dB	16	20	
4. SENSITIVITY FOR 30 dB S/N	90.1 MHz	dB	20	26	
	98.1 MHz	dB	20	26	
	106.1 MHz	dB	20	26	
5. IF REJECTION	90.1 MHz	dB	55	45	
6. IMAGE REJECTION	106.1 MHz	dB	25	22	
7. -3 dB LIMITTING SENSITIVITY	98.1 MHz	dB	22	26	
8. FREQUENCY RESPONSE -6 dB	W/75uS	Hz	125-12000	150-9000	
9. AUTOSTOP SENS.	98.1 MHz	dB	26	32	
10. S/N RATIO 98.1 MHz	60 dB IN	dB	45	38	
11. T.H.D. 98.1 MHz	60 dB IN	%	2	4	
12. OUTPUT POWER 10% THD98.1 MHz	75 kHz DEV	W	10	9.5	
13. OSC FALL-OUT VOLTAGE AC	98.1MHz	V	-30%	-20%	
14. OVERLOAD DIST (75Kz DEV)	98.1 MHz	%	2	3.5	

# KENLEX ELECTRONICS LTD.

24/F., NANYANG PLAZA, 57 HUNG TO ROAD,  
KWUN TONG, KOWLOON, HONG KONG.  
TEL: 27577368, 27577718 FAX: 27519212

## SPECIFICATION

FM MPX SECTION

MODEL : MX-3800(10W)

DATE : 22/MAY/2002

TEST CONDITION : 1 KHz 75 KHz DEV. PILOT = 10%

REF. OUTPUT : 500 mW 4 Ohm

ITEM	UNIT	NORMAL	LIMIT	DATA
1. SEPARATION 98.1 MHz	60 dB IN	dB	28	22
2. STERREO INDICATOR SENS.	98.1 MHz	dB	18	24
3. T.H.D.	98.1 MHz	%	2	4
4. S/N RATIO W/B.P.F 98.1 MHz	60 dB IN	dB	42	36
5. CHANNEL BALANCE	98.1 MHz	dB	0	1.5

# KENLEX ELECTRONICS LTD.

24/F., NANYANG PLAZA, 57 HUNG TO ROAD,  
KWUN TONG, KOWLOON, HONG KONG.  
TEL: 27577368, 27577718 FAX: 27519212

## SPECIFICATION

TAPE SECTION

MODEL : MX-3800(10W)

DATE : 22/MAY/2002

TEST CONDITION :

REF. OUTPUT : 500 mW 4 Ohm

ITEM	UNIT	NORMAL	LIMIT	DATA
1. TAPE SPEED 3KHz	%	+/-1	+3-2	
2. WOW & FLUTTER 3KHz	%	0.2	0.35	
3. CHANNEL BALANCE 1KHz -10dB	dB	1	3	
4. SEPARATION 1 kHz -10dB	dB	35	30	
5. CROSS TALK 1kHz -10dB	dB	35	28	
6. S/N RATIO (PLAYBACK) 1KHz 0dB	dB	45	42	
7. ERASE RATIO (FOR AC.BIAS) 1KHz	dB	40	35	
8. DUBBING LEVEL 1KHz	dB	+/-3	+/-4	
9. FREQ. RESPONSE 125/1K/6.3K (PLAYBACK)	dB	+/-3	+/-6	
10. FREQ. RESPONSE 125/1K/6.3K (REC. PB.)	dB	+/-3	+/-6	
11. DISTORTION (PLAYBACK) 1KHz 0dB	%	1.5	3	
12. DISTORTION(R/P.BACK)FOR AC.BIAS	%	3	5	
13. MINIMUM VOL. HUM	mV	2	4	
14. MAXIMUM VOL. HUM	mV	40	75	
15. OUTPUT POWER 10% THD 1KHz 0dB	W	10	9.5	
16. ERASE RATOR (FOR DC.BIAS)	dB	28	20	
17. DISTORTION(FOR DC.BIAS/ERASE) 1KHz	%	5	8	

# KENLEX ELECTRONICS LTD.

24/F., NANYANG PLAZA, 57 HUNG TO ROAD,  
KWUN TONG, KOWLOON, HONG KONG.  
TEL: 27577368, 27577718 FAX: 27519212

## SPECIFICATION

CD SECTION

MODEL : MX-3800(10W)

DATE : 22/MAY/2002

TEST CONDITION :

REF. OUTPUT : 500 mW 4 Ohm

ITEM		UNIT	NORMAL	LIMIT	DATA
1. FREQUENCY RESPONSE	63 Hz	dB	+/-3	+/-6	
	15 kHz	dB	+/-3	+/-6	
2. S/N RATIO (A WEIGHTED)		dB	55	45	
3. DISTORTION	1KHz 0dB	%	1	2	
	1KHz -20dB	%	2	4	
4. CHANNEL SEPARATION	1KHz	dB	45	38	
5. CHANNEL BALANCE	1KHz	dB	0.5	2	
6. MINIMUM VOL. HUM		mV	2	3	
7. MAXIMUM VOL. HUM		mV	20	30	
8. OUTPUT POWER 10% THD	1KHz 0dB	W	10	9.5	
9. INTERRUPTION		mm	0.7		
10. BLACK DOTS		mm	0.6		
11. FINGER PRINTS		um	65		

ISSUED BY : \_\_\_\_\_





## Spare Patr list

Model no.: TX-3310

Part no.	Description
<b>Ass. Part no.: MX-380</b>	<b>0-1020 MX-3800/10W AKAI (TX-3310)</b>
	<b>AM/FM VDE 230V SILVER/G</b>
1	121-663013-7Y TRANSFORMER EI-66 230V VDE/BS APP W/125 <sup>ML</sup> (M30)& 0.5 SILICON (SF66E/192183) SING FUNG
2	192-300000-02 CLOSE END CONNECTOR UL/VDE APP HW-C4 (TCM & FAVORTRON)
3	198-326130-49 JUMPER WIRE #26 1300mm WHITE UL1007
4	201-033072-18 POWER CORD VDE/SEV APP.72" W/O SOCKET (KE-21 PLUG) (H03VVH2-F)(KENIC)
5	211-010003-09 CD MECHANISM (CMS-FR3GA) W/3CD CHANGER (PROTECH)
6	212-0D1097-23 CASS MECHANISM 12 KEYS THL-21SW-1097C W/CLUTCH (TEAMHAPPY) MOTOR:EG530YD-2BH
7	303-000004-02 CABLE TIE 4" CT-100M (CHEONG WING)
8	500-030802-00 SCREW 3 x 8 P/A
9	500-031003-00 SCREW 3 x 10 B/T
10	500-031007-00 SCREW 3 x 10 W/T
11	500-031010-00 SCREW 3 x 10 W/T WASHER HEAD DIA ?0
12	500-031203-00 SCREW 3 x 12 B/T
13	500-031207-01 SCREW 3 x 12 W/T (BLACK)
14	500-041408-00 SCREW 4 x 14 PWA
15	501-030601-00 SCREW 3 x 6 P/M
16	501-041003-01 SCREW 4 x 10 K/M (BLACK)
17	501-260504-00 SCREW 2.6 x 5 T/T
18	503-153515-00 FIBER WASHER 3.5 x 15 x 1.5mm
19	602-200200-15 PAD CORD 20 x 20 x 15mm W/TAPE
20	605-011000-03 RUBBER FOOT ?1 x 3mm
21	706-088800-A0 RECORDING PLATE (SINO MILLION)
22	707-530100-A0 SCREW PLATE (SINO MILLION)
23	717-088801-A0 CASS P.C.B. MTG. BKT "B" (SINO MILLION)
24	717-088802-A0 CASS P.C.B. MTG. BKT "C" (SINO MILLION)
25	717-088804-A0 CASS P.C.B. MTG. BKT "D" (SINO MILLION)
26	719-882800-00 CASS DOOR SPRING ?.8MM
27	800-380000-03 FRONT CABINET (LCD) STD BRIGHT SILVER SPRAY (A78-030) D.GREY S.S (PMS432C) AKAI DESIGN
28	801-380001-01 REAR CABINET MOULDED GREY (921633) W/O AUX/75 OHM JACK/ SURROUND SPK.JACK
29	802-380000-01 TOP CABINET MOULDED GREY (921633) STD
30	807-380000-01 CDC DOOR BRIGHT SILVER SPRAY (A78-030) STD
31	809-380000-03 CASS DOOR COVER 'L' B.SILVER

		(A78-030)GREY(A-2394)S.S GREY
		(432C),SIL(877C)GREY VER AKAI
32	809-380001-03	CASS DOOR COVER 'R' B.SILVER
		(A78-030)GREY(A-2394)S.S GREY
		(432C),SIL(877C)GREY VER AKAI
33	810-882300-01	CASS DOOR BKT "L" MOULD
		GREY (921633)
34	810-882301-01	CASS DOOR BKT "R" MOULD
		GREY (921633)
35	812-380000-01	CASS KNOB PLAY "L" MOULDED
		GREY (921633)
36	812-380001-01	CASS KNOB PLAY "R" MOULDED
		GREY (921633)
37	813-380000-01	CASS KNOB PAUSE "L" MOULDED
		GREY (921633)
38	813-380001-01	CASS KNOB PAUSE "R" MOULDED
		GREY (921633)
39	814-380000-01	CASS KNOB F.F. "L" MOULDED
		GREY (921633)
40	814-380001-01	CASS KNOB F.F. "R" MOULDED
		GREY (921633)
41	815-380000-01	CASS KNOB REW "L" MOULDED
		GREY (921633)
42	815-380001-01	CASS KNOB REW "R" MOULDED
		GREY (921633)
43	816-380000-01	CASS KNOB STOP/EJECT "L"
		MOULDED GREY (921633)
44	816-380001-01	CASS KNOB STOP/EJECT "R"
		MOULDED GREY (921633)
45	817-380000-01	CASS KNOB RECORD MOULDED GREY
		MOULDED GREY (921633)
46	820-380000-03	CD FUNCTION KNOB (L) B.SILVER
		SPRAY (A78-030) & C.GREY
		(A-2394) W/O S.S AKAI DESIGN
47	820-380001-03	CD FUNCTION KNOB (R) B.SILVER
		SPRAY (A78-030) & C.GREY
		(A-2394) W/O S.S AKAI DESIGN
48	822-380000-02	VOLUME KNOB BRIGHT SILVER
		SPRAY (A78-030) D.GREY S.S
49	832-380000-03	CASS DOOR LENS (L) MOULD CLEAR
		GREY (921543L) W/O S.S
50	832-380001-03	CASS DOOR LENS (R) MOULD CLEAR
		GREY (921543L) W/O S.S
51	835-380000-07	DISPLAY LENS MOULDED GREY LENS
		(921543L) W/SILVER (PMS 877C)
		S.S. AKAI DESIGN
52	836-380000-08	CD DOOR LENS MOULDED GREY LENS
		(921543L) W/SILVER (PMS 877C)
		S.S. AKAI DESIGN
53	836-380001-06	FRONT CABINET LENS MOULDED
		GREY LENS (921543L) W/SILVER
		(PMS 877C) S.S. AKAI DESIGN
54	838-011800-00	DAMPER GEAR
55	839-011800-00	GEAR HOLDER
56	843-380000-00	LCD BRACKET
57	845-380000-01	VOL. KNOB BRACKET (CHROME)
58	845-380001-00	MAIN PCB BRACKET
59	845-380002-00	SENSOR PCB BRACKET
60	901-380000-02	GIFT BOX AKAI DESIGN (TX-3310)
61	902-380000-04	INSTURCTION MANUAL AKAI DESIGN
		(TX-3310) (ENG/DUT/FRE)
62	912-380000-00	RATING PLATE (41.6x17.6x0.3)mm

63	912-380020-00	BACK LIGHT FILM
64	912-380022-00	BACK LIGHT PLATE (AMBER)
65	919-000001-01	SERIAL No. LABEL STD.
66	919-088802-01	LASER BEAM LABEL YELLOW STD
67	919-088803-06	LASER CAUTION LABEL YELLOW B/G W/BLK STD (NEW)(2000 YEAR VER)
68	919-088804-02	CLASS 1 LABEL YELLOW STD
69	919-088813-01	THERMAL FUSE LABEL 125馬
70	919-380016-01	IMPEDANCE LABEL AKAI DESIGN (TX-3310) 10W 8 OHM
71	919-380099-04	P.R.C. LABEL
72	919-380099-05	VERSION CODE LABEL "E1"
73	920-380000-04	RATING LABEL AKAI DESIGN (TX-3310)
74	930-380001-00	POLYFOAM SPK BOX "TOP" (140MM DEPTH)
75	930-380002-00	POLYFOAM MAIN UNIT & SPK BOX "TOP"
76	930-380003-00	POLYFOAM MAIN UNIT "TOP"
77	930-380004-00	POLYFOAM SPK BOX "BOTTOM"
78	930-380005-00	POLYFOAM MAIN UNIT & SPK BOX "BOTTOM"
79	930-380006-00	POLYFOAM MAIN UNIT "BOTTOM"
80	960-100504-02	POLYBAG 10"(L) x 5"(O) W/PRINTING
81	960-221904-01	POLYBAG 22"(L) x 19"(W) x 0.04mm W/PRINTING & PUNCH HOLE
82	960-292804-01	POLYBAG 29(L) x 28(W) x 0.04mm W/PRINTING & PUNCH HOLE
83	K-003D-0003	RH-03D (19 KEYS ) REMOTE PART ASS'Y MOULD GREY(COOL GREY/5C) (W/O RDS & AUX) AKAI DESIGN
84	PCB-380001-01	P.C.B. MAIN ASS'Y (10W) AM/FM (NEW)
85	PCB-380002-02	P.C.B. CONTROL CD KEY ASS'Y (W/O RDS) (NEW)
86	PCB-380003-01	P.C.B. POWER ASS'Y (10W) (NEW)
87	PCB-380004-02	P.C.B. CASS ASS'Y (NEW) (CHINA MOTOR)
88	SPL-380010-06	SP-3800/10W SPK PART LIST "L" B.SILVER (A78-030) GREY GRILL D.GREY CLOTH (JY-LE-7) "AKAI"
89	SPR-380010-06	SP-3800/10W SPK PART LIST "R" B.SILVER (A78-030) GREY GRILL D.GREY CLOTH (JY-LE-7) "AKAI"

25-nov-02

Qty.
1.0000
2.0000
1.0000
1.0000
1.0000
1.0000
6.0000
3.0000
19.0000
5.0000
1.0000
2.0000
11.0000
4.0000
4.0000
4.0000
2.0000
2.0000
1.0000
4.0000
1.0000
4.0000
1.0000
1.0000
1.0000
2.0000
1.0000
1.0000
1.0000
1.0000
1.0000



2.0000
1.0000
1.0000
1.0000
1.0000
1.0000
1.0000
2.0000
1.0000
2.0000
1.0000
1.0000
1.0000
1.0000
1.0000
1.0000
1.0000
1.0000
2.0000
1.0000
1.0000
1.0000
1.0000
1.0000
1.0000
1.0000