

AKAI

MODEL GXC-570D

PRELIMINARY SERVICE MANUAL

PRELIMINARY SERVICE MANUALMODEL GXC-570DDATE August 1976

Technical Data

- 1) Track System 4 track 2 channel stereo system
- 2) Tape Philips type cassette
- 3) Tape Speed 1-7/8 ips. (Pitch Control $\pm 5\%$)
- 4) Wow and Flutter
Less than 0.06% WRMS
Less than 0.17% (DIN 45500)
- 5) Frequency Response
30 Hz to 15,000 Hz (± 3 dB), using low noise tape
30 Hz to 16,000 Hz (± 3 dB), using CrO₂ tape
30 Hz to 19,000 Hz (± 3 dB), using Fe-Cr tape
- 6) Distortion Less than 1% (1,000 Hz "0" VU), using low noise tape
- 7) Signal to Noise Ratio
Better than 52 dB (measured via tape with peak recording level of +5 VU)
Dolby Switch ON: Improves up to 10 dB above 5 kHz
- 8) Erase Ratio Better than 70 dB
- 9) Bias Frequency 100 kHz
- 10) Heads GX recording/playback head and erase head (3 head system)
- 11) Motors One AC Servo outer-rotor motor for capstan drive and two DC motors for reel drive
- 12) Fast Forward and Rewind Time 60 to 80 seconds (Variable) using a C-60 cassette tape
- 13) Output Jacks
Line(2): 0.775V ("0" VU) Required load
Impedance: More than 20 k ohms
Phono(1): 50 mV/8 ohms
- 14) Input Jacks
Microphone(2): 0.3 mV. Required microphone
Impedance: 600 ohms
Line(2): 70 mV/100 k ohms
- 15) Semiconductors Transistors 110, Diodes 159, FETs 12, ICs 9
- 16) Power Requirements
CSA, UL and LA Models: 120V, 60 Hz only
CEE Models: 220V, 50 Hz only
Other Models: 100V to 240V, 50/60 Hz, (Switchable)
- 17) Dimensions 440(W) x 255(H) x 225(D)mm
(17.3 x 10.0 x 8.9")
- 18) Weight 13.5 kg (28.5 lbs)

I. Principal Parts Location

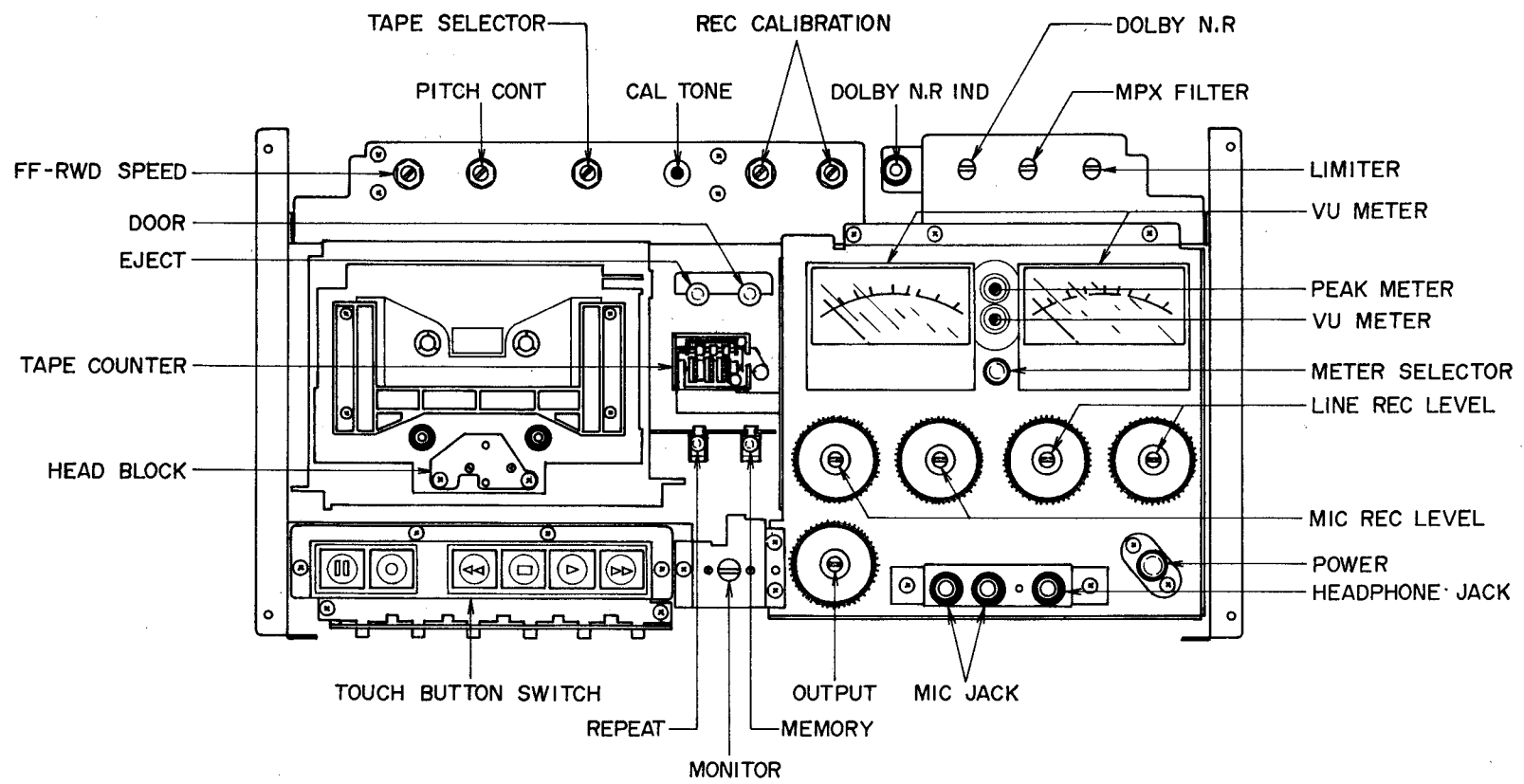

Fig. 1 Front View

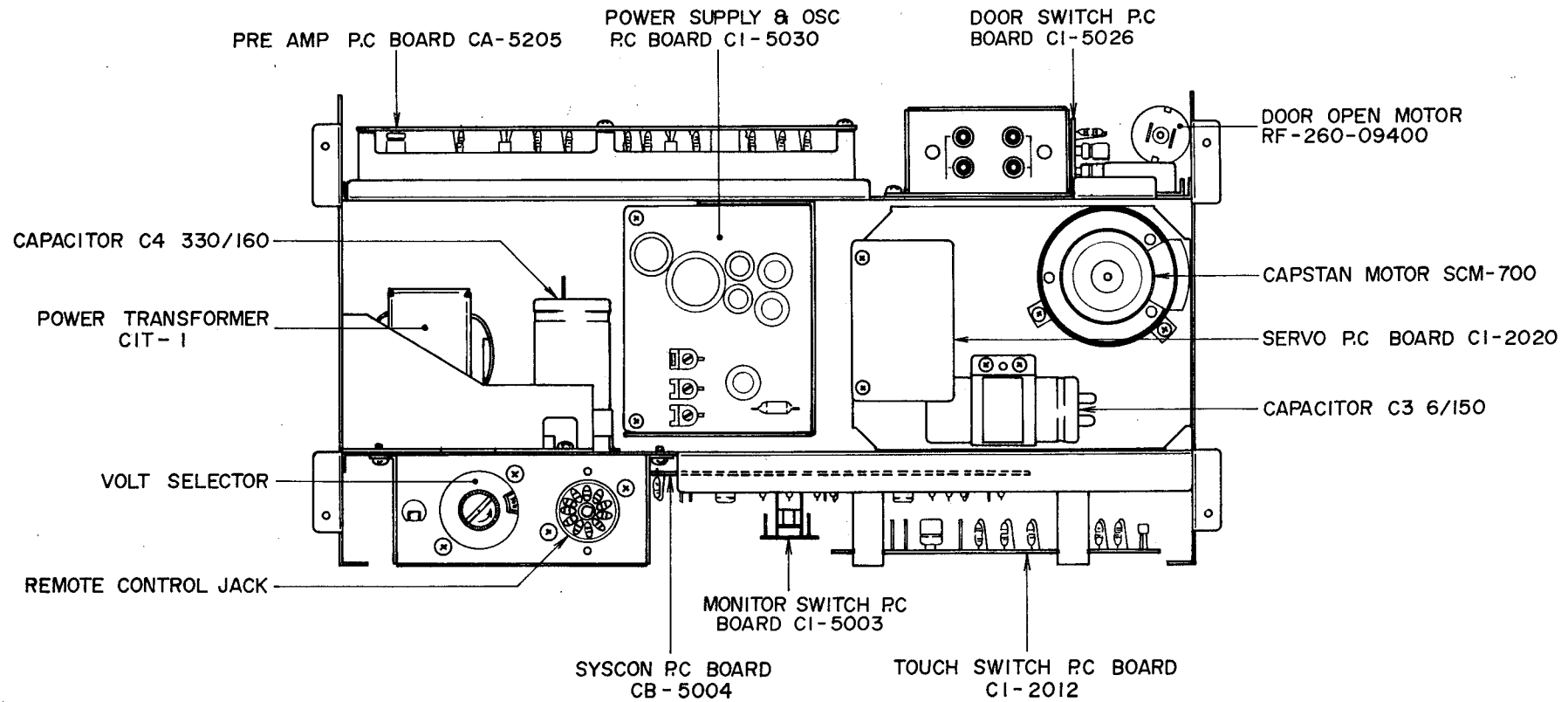

Fig. 2 Rear View

2. Mechanism Adjustment

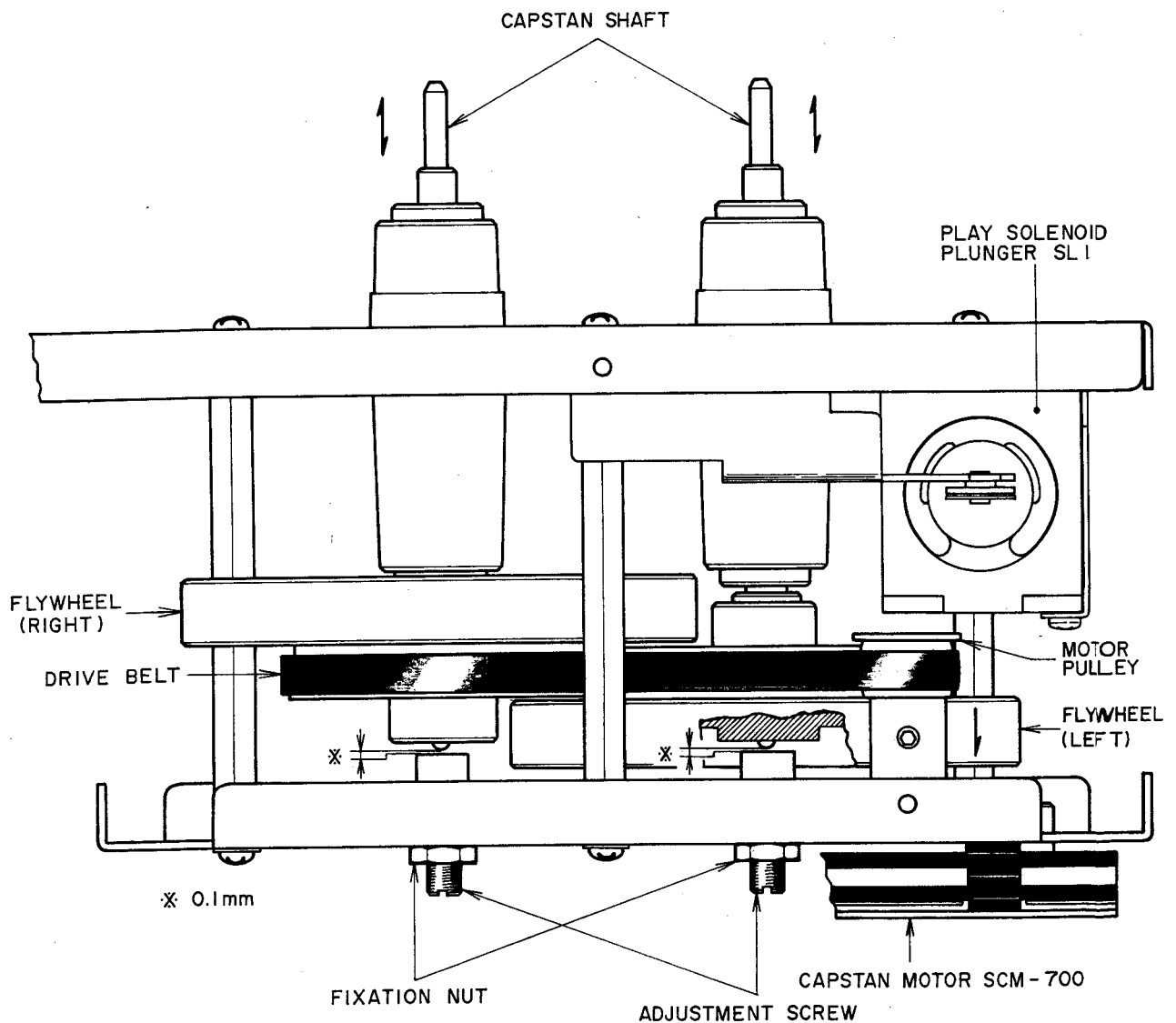

Fig. 3

1) Capstan Shaft Loose Play Adjustment (Refer to Fig. 3)

Adjust by turning adjustment screws to obtain a 0.1 mm degree of loose play (space indicated by * mark in fig. 3) when the capstan shaft is moved as indicated by the arrow mark. Tighten fixation nut to maintain optimum adjusted condition.

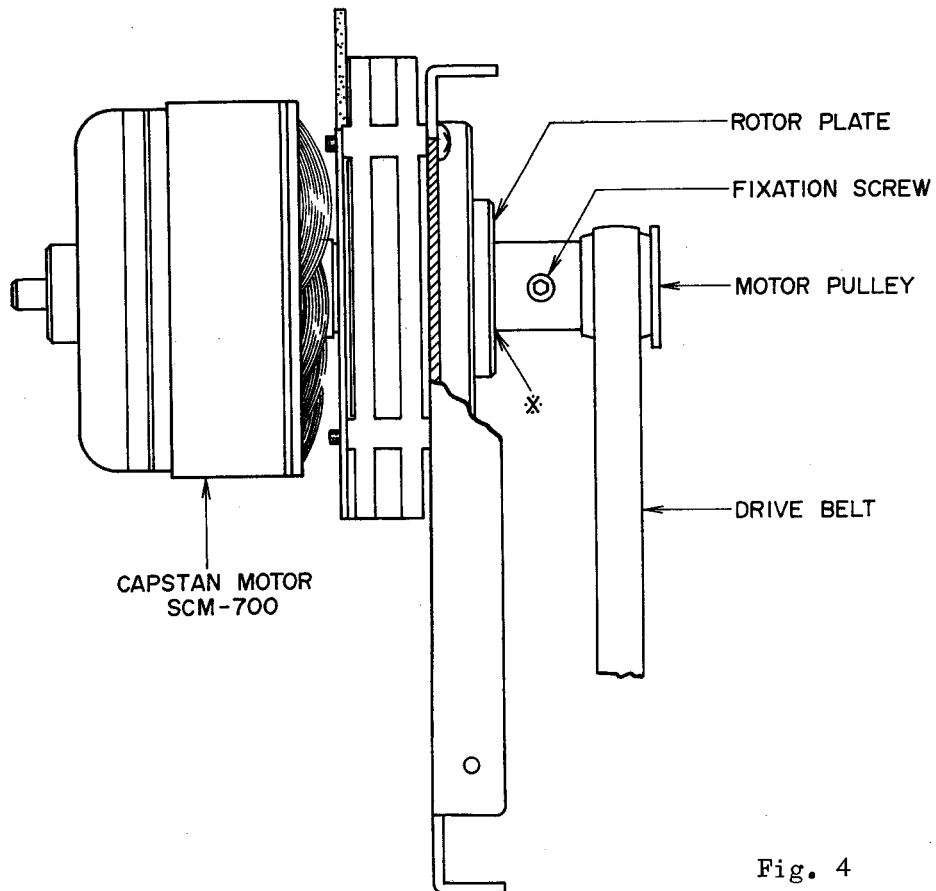
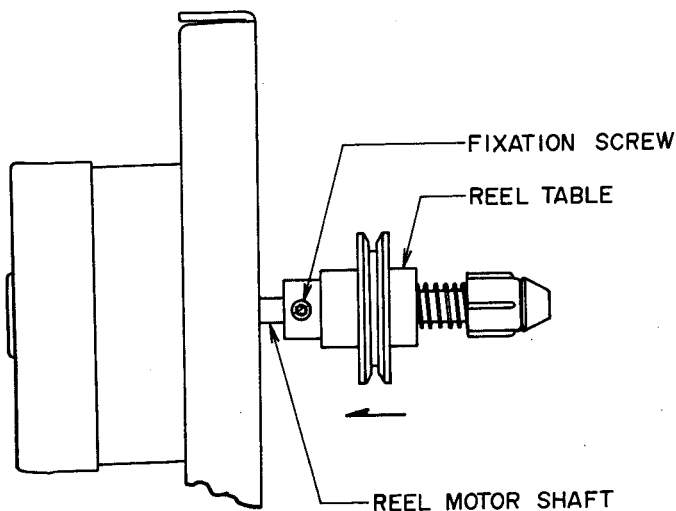

Fig. 4

2) Motor Pulley Installation Position Adjustment (Refer to Fig. 4)

Tighten fixation screw at position at which the parts indicated by the * mark in fig. 4 makes contact with the rotor plate.

NOTE: After above adjustment, in case the drive belt does not run on the center of Motor Pulley, re-adjust installation position of Motor Pulley so that the drive belt comes to the center of the Pulley.



3) Reel Table Installation Position Adjustment (Refer to Fig. 5)

As shown in Fig. 5, with reel table firmly and completely fitted on motor shaft, tighten fixation screw.

Fig. 5

4) Pinch Roller Pressure Adjustment (Refer to Fig. 6)

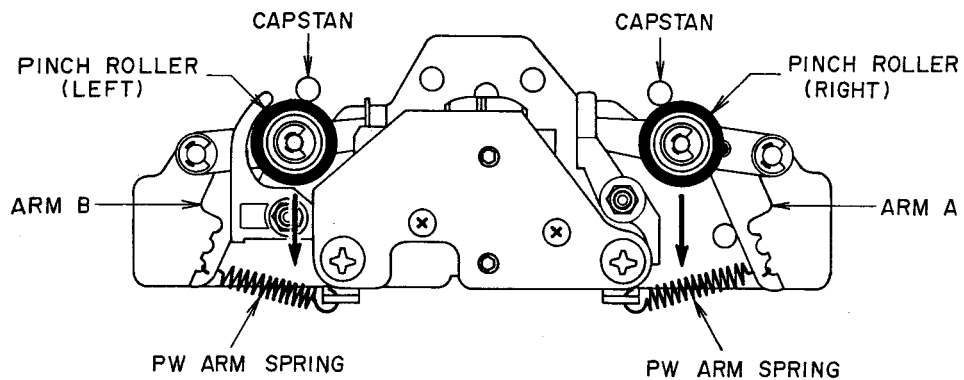

Fig. 6

Pull back the Pinch Roller with a spring gauge, and then gently return. Take a reading of the spring gauge scale indication at the moment the Pinch Roller touches the capstan and begins to rotate. Adjust pressure to specified value by changing position of the PW ARM SPRING.

Specified Pinch Roller Pressure: Pinch Roller (right) 400 ± 50 gm
Pinch Roller (left) 300 ± 50 gm

5) Play Solenoid Installation Position Adjustment (Refer to Fig. 7 and Fig. 8)

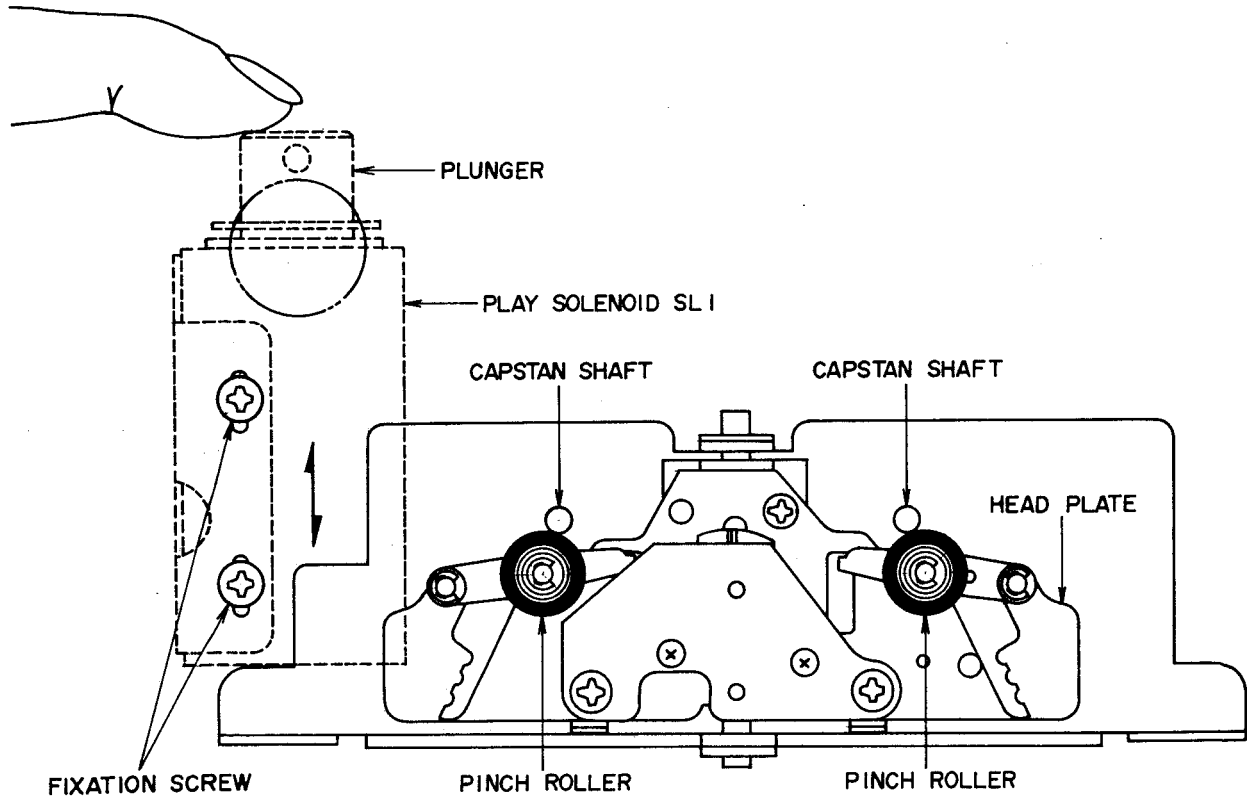

Fig. 7

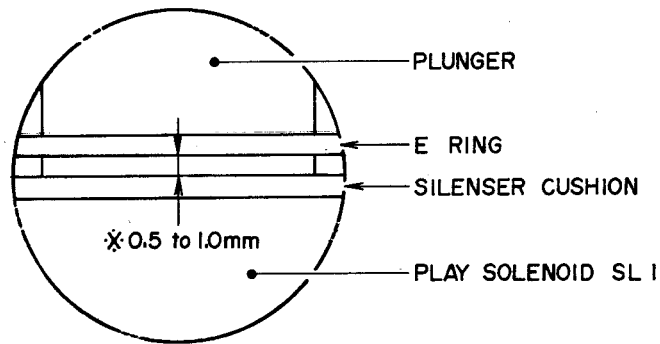

Fig. 8

As shown in Fig. 7, at stop mode, when the tip of plunger is gently depressed, the pinch roller contacts the capstan shaft, at this time confirm that the gap between "E" ring and silencer cushion is 0.5 to 1.0 mm. (See fig. 8)

If not, adjust play solenoid installation position as indicated by the arrow mark in Fig. 6 to obtain specified gap.

6) Adjustment of Eject Micro Switch Actuating Position (Refer to Fig. 9)

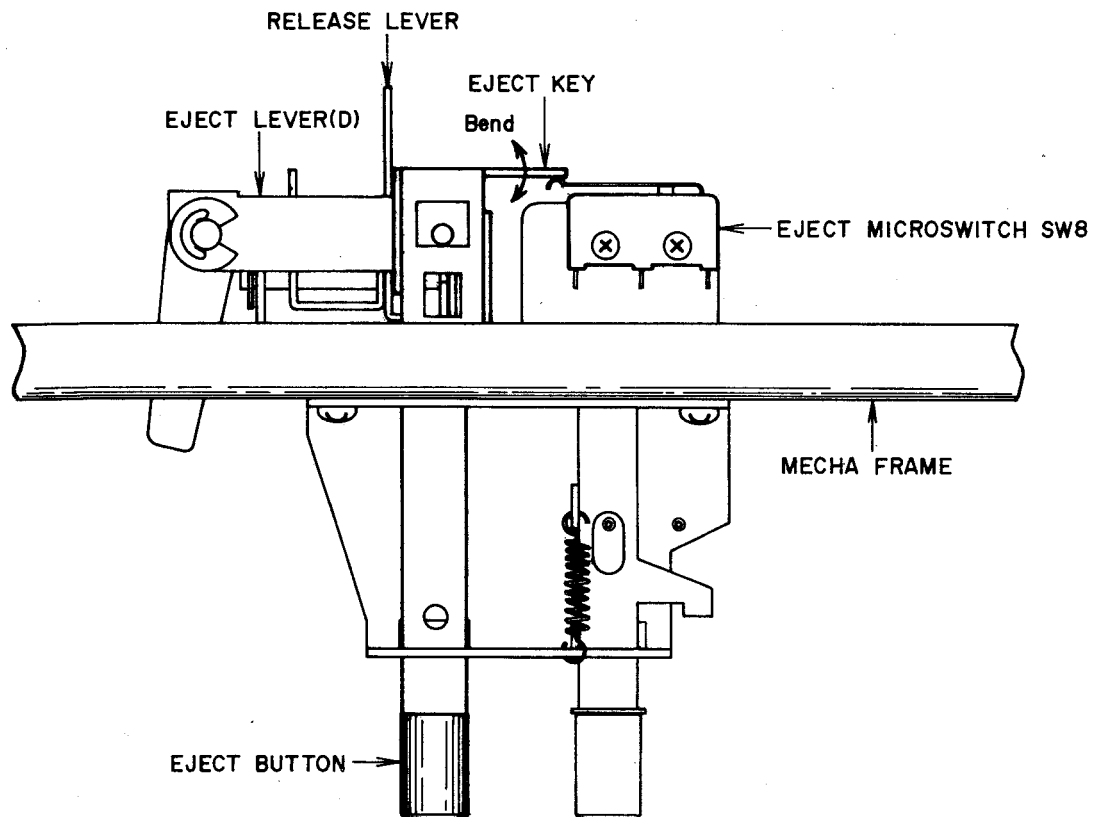

Fig. 9

Adjust by bending Eject Key so that when the Eject Key is depressed, Eject Micro Switch (SW8) shown in fig. 9 is perfectly actuated.

After adjustment, depress Eject Button and confirm that Eject Micro Switch (SW8) switches before the Release Lever operates.

7) Adjustment of Recording Micro Switch (SW3) and Cassette Micro Switch (SW6)
Actuating Position (Refer to Fig. 10)

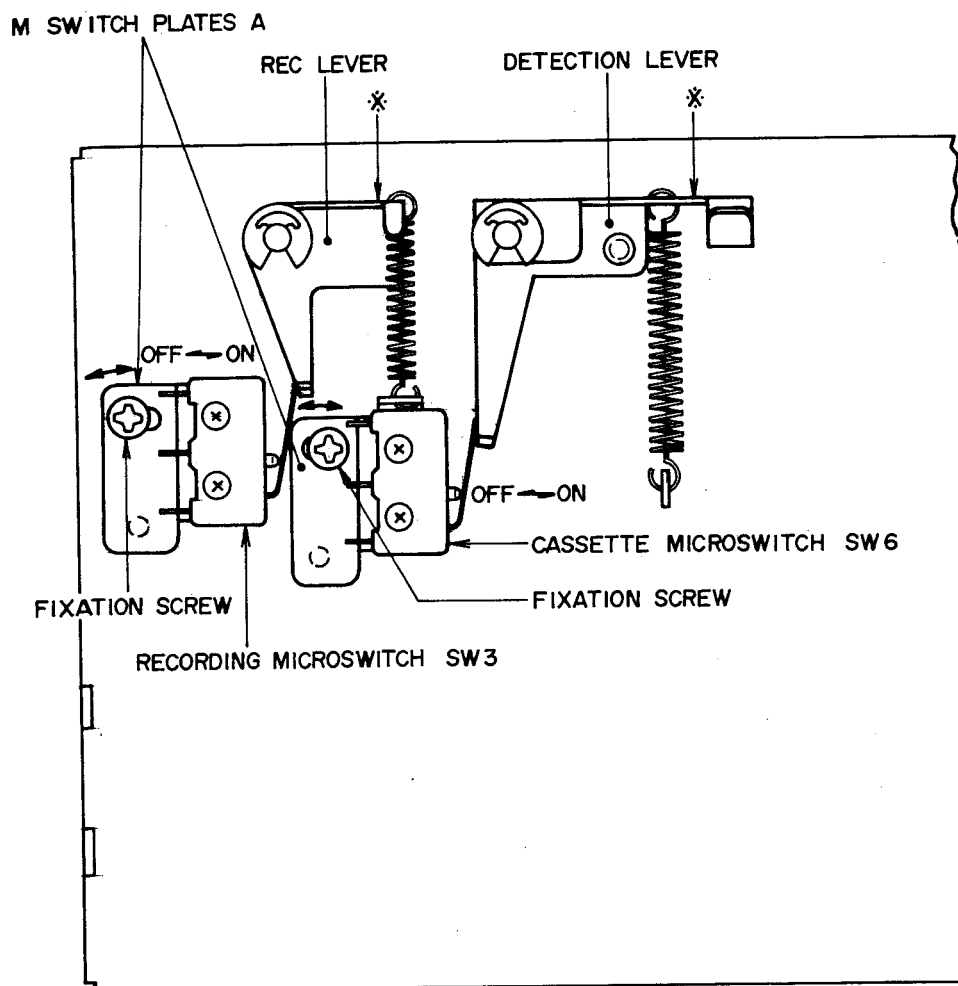

Fig. 10

Move M Switch Plate A as indicated by the arrow marks in the figure and adjust so that when the parts of Recording and Detection Levers marked with * mark in Fig. 10 are at a horizontal level, Recording Micro Switch (SW3) and Cassette Micro Switch (SW6) are turned ON respectively. Further, confirm that when a cassette from which the recording safety tabs have been removed is loaded, Recording Micro Switch (SW3) switches, and when the cassette is removed, Cassette Micro Switch (SW6) switches. Tighten fixation screws to maintain ideally adjusted positions of M Switch Plates A.

8) Reel Motor (GSM-300) Replacement (Refer to Fig. 11)

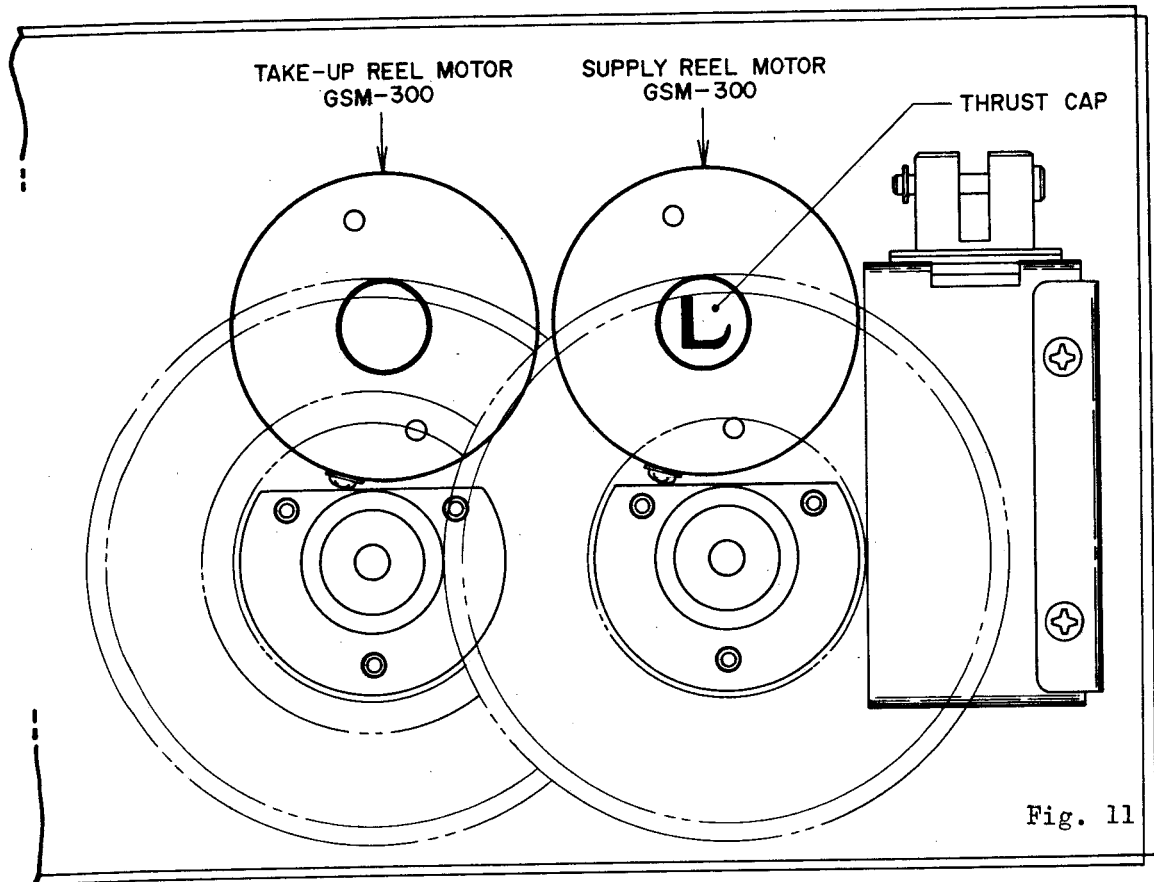

Fig. 11

While the reel motors of this Deck are basically the same, because left and right characteristics differ, check as described below prior to replacement.

Supply Reel Motor: marked with L on thrust cap

Take-up Reel Motor: no marking

NOTE: If same type motor is not used, brush noise will occur.

9) Front Panel Lid Case Spacing Adjustment (Refer to Fig. 12)

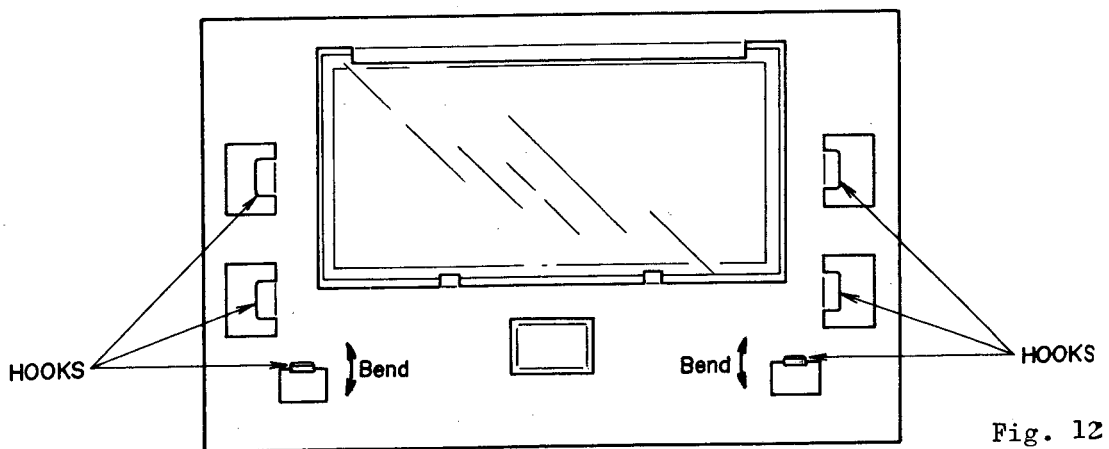

Fig. 12

In case the Lid Case comes too far toward either side, adjust by bending the two lower hooks as indicated by the arrow marks in Fig. 12.

10) Position Adjustment of Lid Case (Refer to Fig. 13)

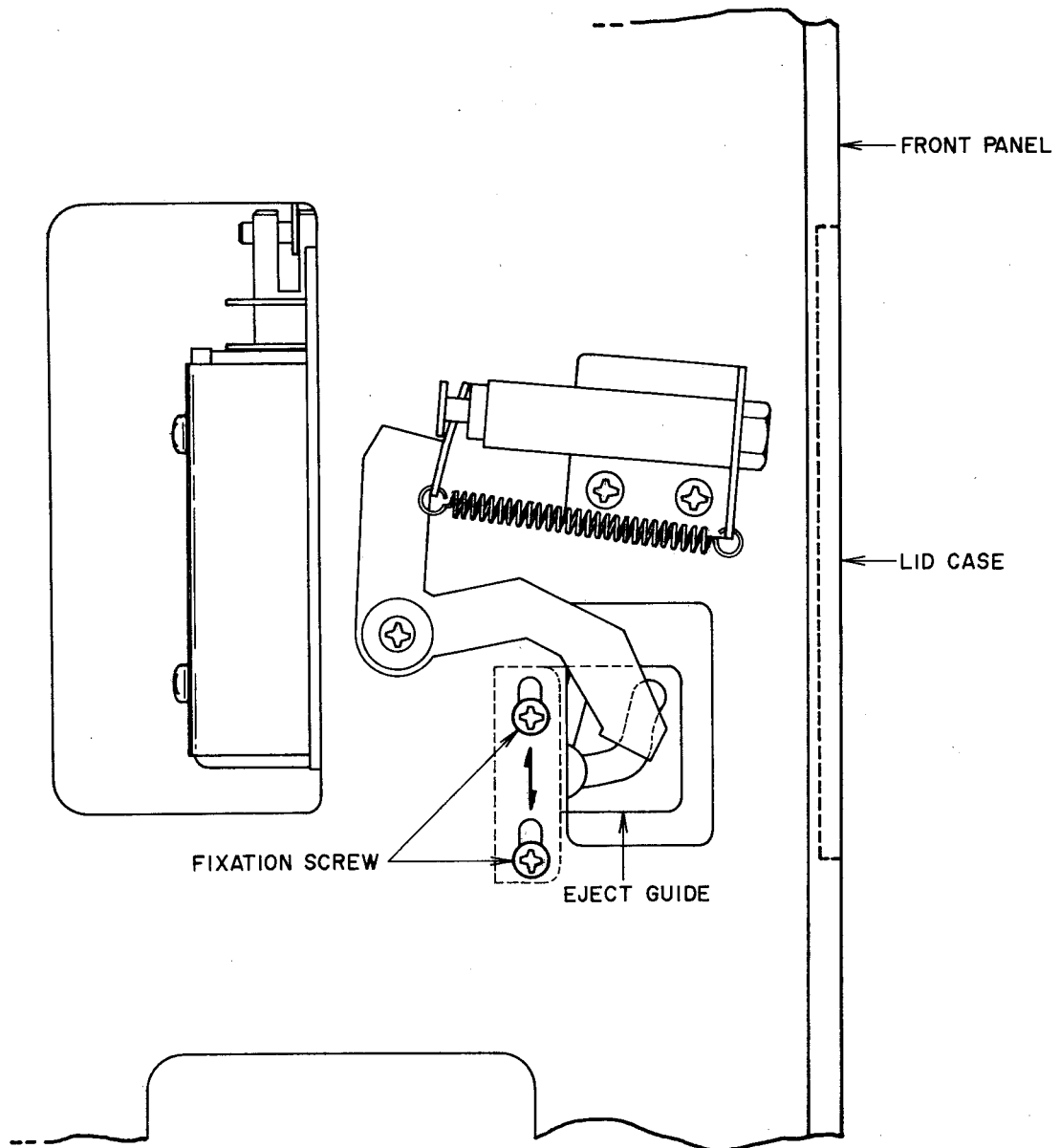

Fig. 13 Left Side of the Deck

Move the Eject Guide shown in Fig. 13 (direction indicated by arrow mark) up and down and adjust Lid case so that it is even with the front panel. If the upper part of Lid case comes too far inward, raise the eject guide, and if too far outward, lower eject guide.

11) Clearance Adjustment Between Hall IC and Rotary Magnet (Refer to Fig. 14)

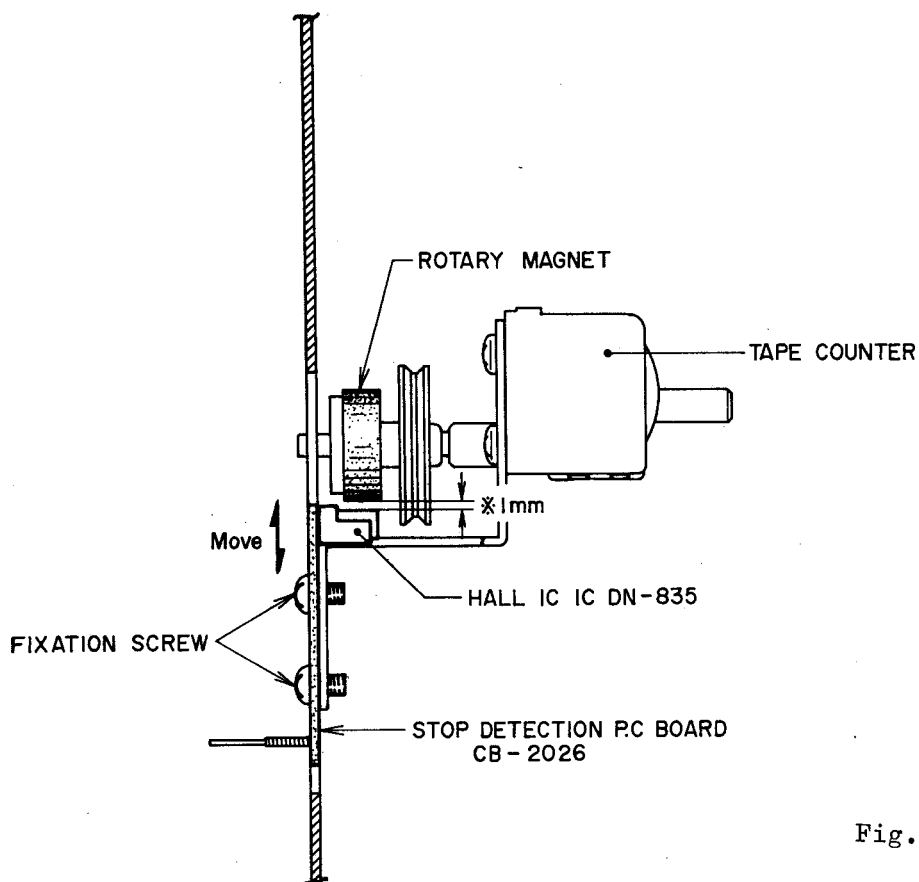

Fig. 14

This adjustment is necessary for the perfection of the Automatic Stop Function. If adjustment is necessary due to poor Automatic Stop Function or instability, proceed as follows:

- a. As shown in Fig. 14, move Stop Detection P.C Board as indicated by the arrow mark in the figure, and adjust position so that the clearance between the Hall IC and rotary magnet is 1 mm.
- b. In case this clearance is over 1 mm, faulty Automatic Stop Function will occur.

3. Head Adjustment

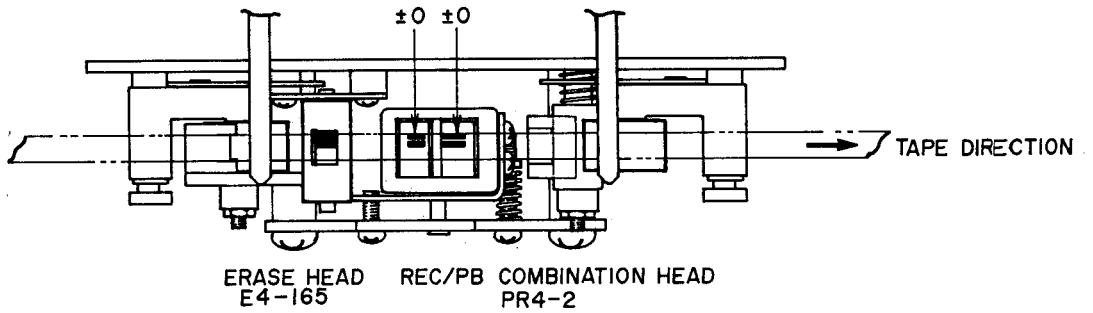
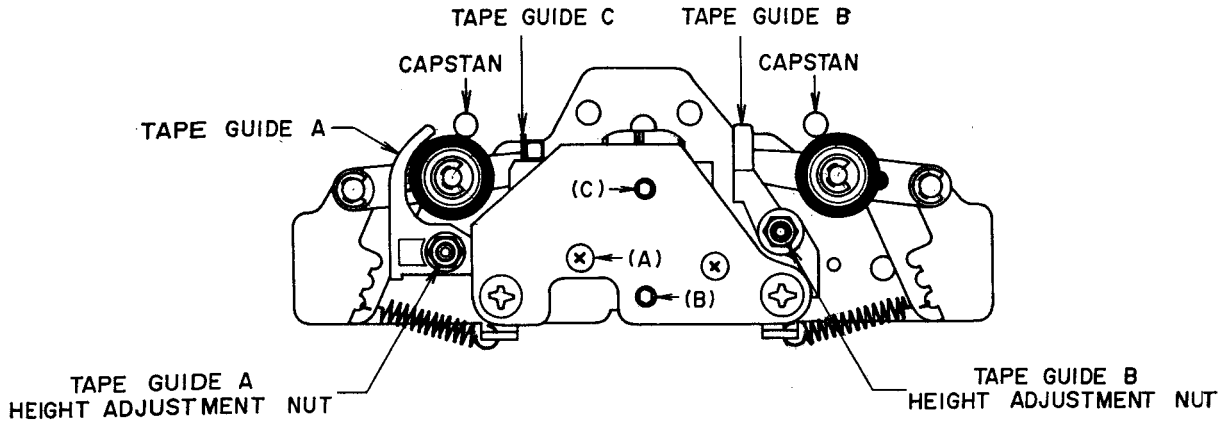

Fig. 15

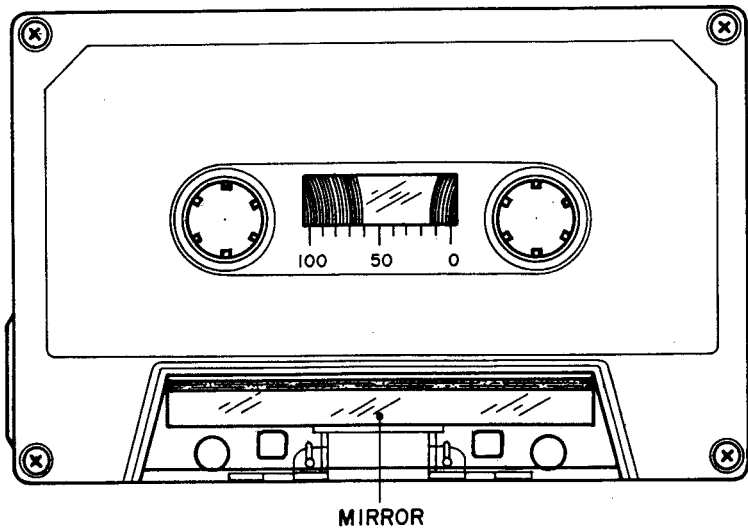

Fig. 16

- 1) Tape Guide Height Adjustment (Refer to Fig. 15 and Fig. 16)
 - a. When using an ordinary cassette, the tape guides and heads, etc. are not visible. As shown in Fig. 16, use a cassette tape from which part of the cassette case has been cut out and a mirror installed for easy visibility of the head area when making tape guide height adjustment.
 - b. At playback mode, using the erase head guide C shown in Fig. 15 as standard for height, adjust tape guide A and tape guide B height with tape guide height adjustment nuts so that the tape runs smoothly and does not catch on the tape guides.
- 2) Height Adjustment of Recording/Playback Combination Head (Refer to Fig. 15)
 - a. Utilize the cassette tape used in Tape Guide Height Adjustment above, and playback the leader tape part of cassette tape.
 - b. As shown in Fig. 15, adjust head height with screws (A), (B), and (C) until the upper edge of the tape is the same height as the upper edge of the left channel REC/PB Comb. head core.
- 3) Azimuth Alignment Adjustment of Recording/Playback Combination Head (Refer to Fig. 15)
 - a. Playback a 10 kHz pre-recorded cassette azimuth alignment test tape and adjust screw (A) shown in Fig. 15 to obtain maximum output on both channels.
 - b. Invert cassette and confirm that the output level does not change from that obtained in Item 3)-a above. If the output level differs, adjust in the same way as in Item 3)-a above until both sides of the test tape display equal output
 - c. Supply a 10 kHz signal from an audio frequency oscillator to the line inputs and record at -20 VU on a blank tape.
 - d. Set Monitor Switch to "TAPE" position and adjust screw (A) shown in Fig. 16 to obtain maximum output on both left and right channels.
 - e. The recording and playback heads are joined to form a single structure. Therefore, when making azimuth alignment adjustments, because both head cores (recording and playback) move, repeat adjustments outlined in Items 3)-a through 3)-d above until optimum azimuth alignment of the two head cores are obtained.

- NOTES:
1. Be sure to clean the heads prior to head adjustment.
 2. Be careful not to use a magnetized driver or other magnetized tools in the vicinity of the heads.
 3. Be sure to demagnetize the heads with a Head Demagnetizer before and after head adjustment.
 4. When a mirror installed cassette test tape as shown in Fig. 16 is required, it can be ordered from AKAI Electric Co.

4. Amplifier Adjustment

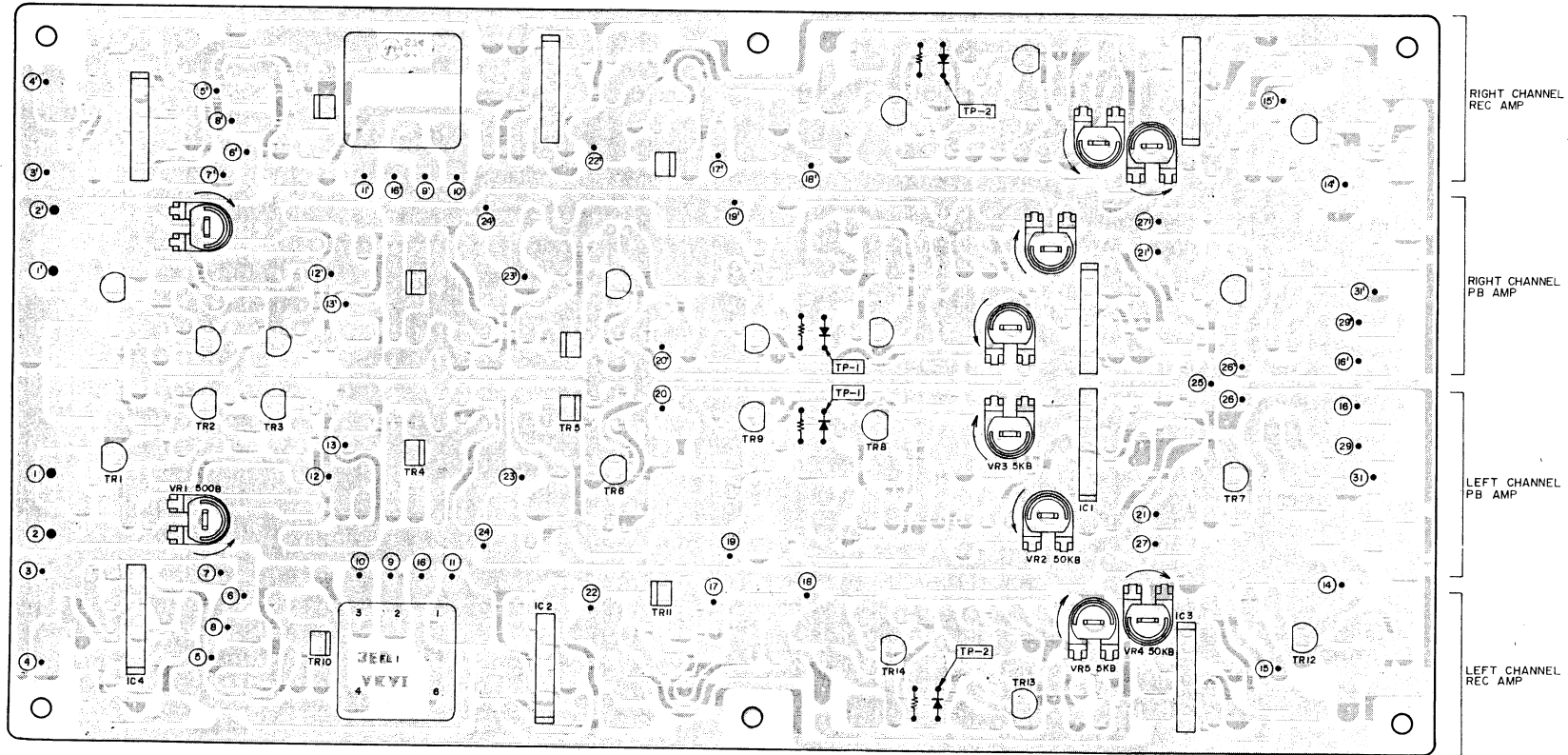

Fig. 17 Pre Amp P.C Board CA-5205

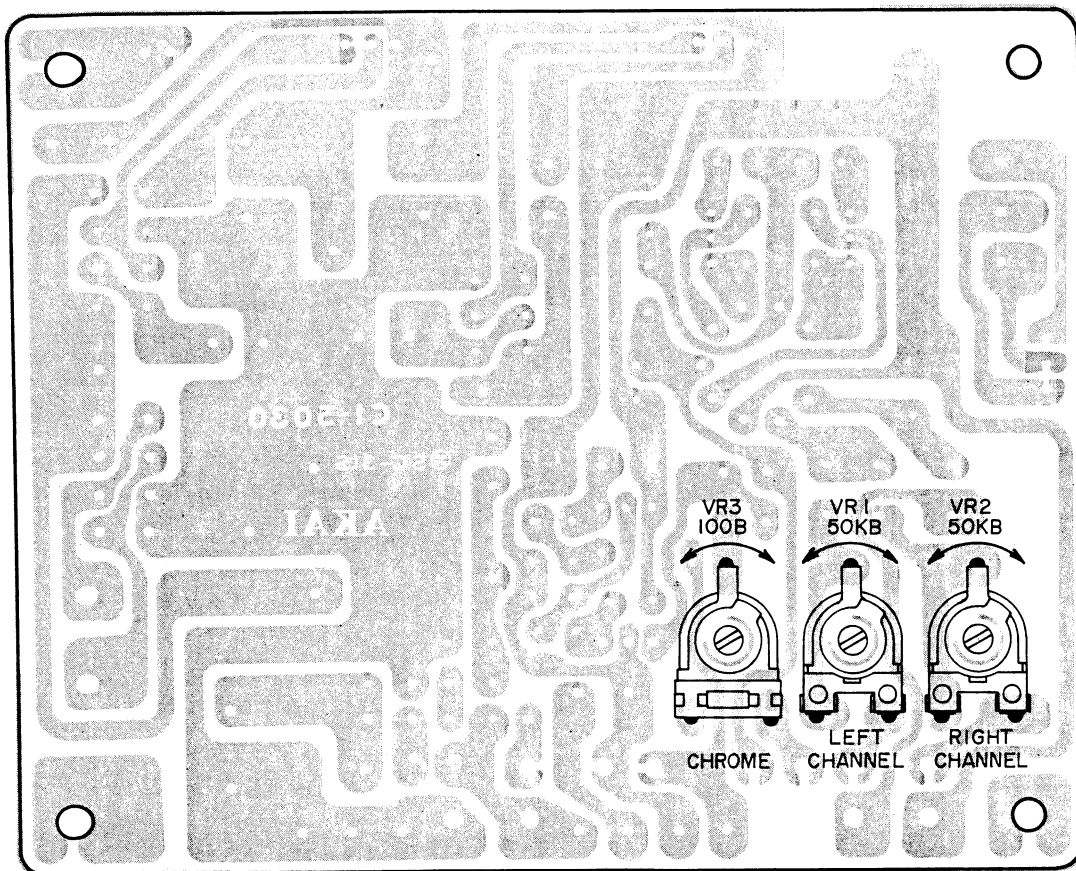

Fig. 18 Power Supply & OSC P.C Board CI-5030

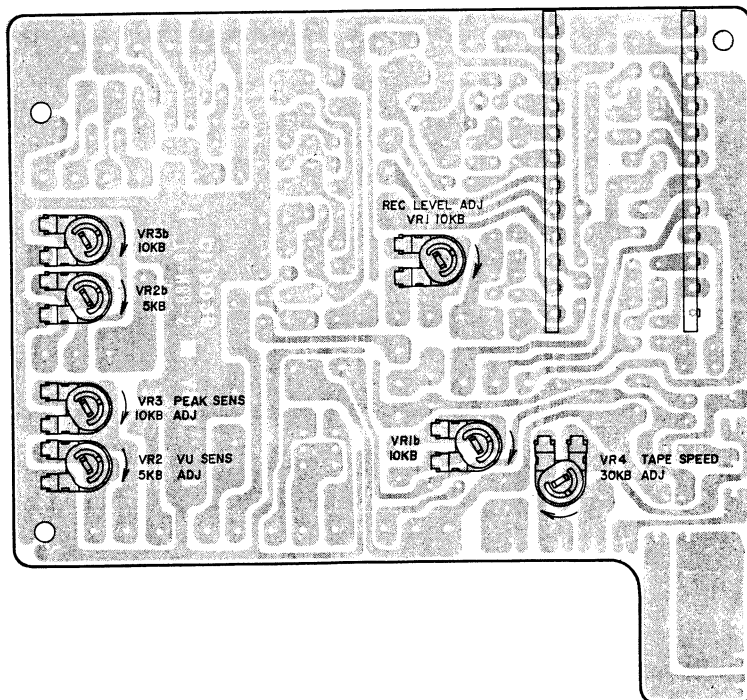

Fig. 19 Equalizer P.C Board CI-5028

1) Recording/Playback Amplifier Adjustment(Refer to Fig. 17,18 and 19 and Chart 1)						
Step	Adjustment Item	Test Tape Supply Signal	Mode	Adjustment point	Result	Remarks
1	Playback Level Adjustment	333 Hz 0 VU Test Tape	PLAY	VR1 500B (CA-5205)	0 \pm 0.5 dBm (0.775V)	Set Monitor Switch to "TAPE".
2	Recording Level Adjustment (low noise tape)	Low Noise Blank Tape 1,000 Hz 0 VU recording	REC	VR1 10 kB (left channel) VR1b 10 kB (right channel) (CI-5028)	0 \pm 0.5 dBm (0.775V)	Set Monitor Switch to "TAPE" Refer to Note-1)
3	Recording Level Adjustment (chrome tape)	Chrome Blank Tape 1,000 Hz 0VU recording	REC	None	0 \pm 0.5 dBm	Set Monitor Switch to "TAPE" Refer to Note-2)
4	Frequency Response Adjustment (low noise tape)	Low Noise Blank Tape 1,000 Hz 10,000 Hz -20 VU recording	REC	VR1 50 kB (left channel) VR2 50 kB (right channel) (CI-5030)	1,000 Hz 10,000 Hz Flat response	Set Tape selector to "LOW NOISE"
5	Frequency Response Adjustment (chrome tape)	Chrome Blank Tape 1,000Hz 10,000 Hz -20 VU recording	REC	VR3 100B (CI-5030)	1,000 Hz 10,000 Hz Flat response	Set Tape selector to "CHROME"
6	Recording Level Confirmation (low noise tape)	Low Noise Blank Tape 1,000 Hz 0 VU recording	REC	VR1, VR1b 10 kB (CI-5028)	0 \pm 0.5 dBm	Refer to Note-3)
7	VU Meter Sensitivity Adjustment	1,000 Hz	STOP	VR2, VR2b 5 kB (CI-5028)	0 VU	Set Meter Selector to "VU METER" Refer to Note-4)
8	Peak Meter Indication Adjustment	1,000 Hz	STOP	VR3, VR3b 10 kB (CI-5028)	-8 VU	Set Meter Selector to "PEAK METER" Refer to Note-4)

Notes:

- a. Recording level adjustment volumes (REC CAL) VR5 and VR6 are not located on the Pre-Amp P.C Board as in the case of an ordinary tape deck, but are installed on the front panel. When adjusting VR1 and VR1b, set VR5 and VR6 to center position.
- b. After low noise tape adjustments, confirm recording level only.
- c. Following Step 4 frequency response adjustment, because the recording level may be slightly changed, confirm level and if necessary, carry out Step 2 adjustment again.
- d. Set Monitor Switch to "SOURCE" and supply a 1,000 Hz signal to line input to obtain a 0 dBm line output level.
- e. Because each of these adjustments are vital to perfect Dolby N.R. circuit operation, be sure that they are carried out with as little error as possible.
- f. Use the following cassette measuring tape:
 - Low Noise Tape: Fuji C-60LN
 - Chrome Tape: BASF #SM Chrome C-60

2) Dolby Noise Reduction Circuit Adjustment (Refer to Fig. 17)

NOTES:

- a. Because the establishment of the (5 kHz) adjustment signal and level etc. is vital to correct Dolby Noise Reduction circuit adjustment, use only calibrated measuring instruments.
- b. Level deviation must be within ± 0.5 dB.
- c. After Dolby Noise Reduction circuit adjustments have been made, do not change recording and playback levels.

3) Recording Dolby Noise Reduction Amplifier Adjustment (Refer to Fig. 17)

- a. Set Monitor Switch to "SOURCE", and Tape Selector Switch to "LOW NOISE".
- b. Ground Test Point TP2 and turn adjustment semi-fixed resistors VR4 (50 kB) and VR5 (5 kB) as far as they will go in the direction of the arrow mark.
- c. With Line Recording Level Volume set to 12 o'clock position, supply a 5 kHz signal to the line input and obtain a -28.5 dBm line output level.
- d. Connect a Voltmeter to the center terminal of EQ P.C Board Rec Level Volume VR1 (left channel) and VR1b (right channel), and adjust Rec Level Volume obtain a -30 dBm AC Voltmeter indication.
- e. With the Dolby Noise Reduction Switch at ON, adjust semi-fixed resistor VR4 (50 kB) shown in Fig. 17 to obtain a -20 dBm level at center terminal of Rec Level Volume
- f. Disconnect Test Point TP2 from ground and adjust semi-fixed resistor VR5 (5 kB) shown in Fig. 17 to obtain a -22 dBm level at center terminal of Rec level Volume.

- 4) Playback Dolby Noise Reduction Amplifier Adjustment (Refer to Fig. 17)
- Set Monitor Switch to "TAPE" and Tape Selector Switch to LOW NOISE.
 - Ground Test Point TP1 and turn adjustment semi-fixed resistors VR2 (50 k Ω), and VR3 (5 k Ω) as far as they will go in the direction of the arrow mark.
 - Set deck to playback mode.
 - Supply a 5 kHz signal to terminal (13) shown in Fig. 17 and obtain a -20 dBm line output level.
 - Set the Dolby Noise Reduction Switch to ON and adjust semi-fixed resistor VR3 (5 k Ω) to obtain a -30.5 dBm line output level.
 - Disconnect Test Point TP1 from ground and adjust semi-fixed resistor VR3 (5 k Ω) to obtain a -28.5 dBm line output level.

Noise reduction circuit made under license from Dolby Laboratories Inc.

The word 'DOLBY' and the Double-D symbol are trademarks of Dolby Laboratories Inc.

5. DC Resistance of Various Coils

Part	Designation	DC Resistance
Main Motor	SCM-700	Between YLW-BLU 210 ohms Between YLW-RED 197 ohms Between RED-BLU 190 ohms Pick-up coil 670 ohms
Play Solenoid	1660THT2	700 ohms $\pm 10\%$
Relay	MTS-2	1,000 ohms $\pm 10\%$
Relay	LC1-C-JT	1,140 ohms $\pm 10\%$
Headphone Output Transformer	N19-349S	Primary 160 ohms $\pm 15\%$ Secondary 0.64 ohms $\pm 15\%$
Oscillator Coil	OT-925	Between 1-3 0.3 ohms Between 4-6 1.5 ohms Between 7-9 6.1 ohms
Recording, Playback Combination Head	PR4-2	Recording 22 ohms $\pm 5\%$ Playback 250 ohms $\pm 5\%$
Erase Head	E4-165	2.5 ohms

Chart-2

6. Basic Parts List

Parts Nomenclature	Parts No.	Note
Case CI-6024	BC691301	
Front Panel Block Comp. CI-9723	BD681118	
Panel Washer CI-6018	ZW691266	
Panel Screw CI-6019	ZS691277	
Lid Panel Block Comp.	BD681120	
Lamp P.C Board Comp. CA-2064	BA647190	
Switch P.C Board Comp. CI-5029	BA681287	
Noise Filter P.C Board Comp. CB-2027	BA670230	Same as GXC-740D, GXC-760D
Servo P.C Board Comp. CI-2020	BA681175	
Syscon P.C Board Comp. CB-5004	BA681210	
Pre Amp P.C Board Comp. CA-5205	BA681276	
Touch Switch P.C Board Comp. CI-2012	BA681254	
Power Supply & OSC P.C Board Comp. CI-5030	BA681221	
Protection P.C Board Comp. CB-5028	BA671207	CEE, CSA, JPN Models. Same as GXC-760D
Stop Detection P.C Board Comp. CB-2026	BA670195	Same as GXC-760D
Monitor Switch P.C Board Comp. CI-5003	BA681333	
Peak Switch P.C Board Comp. CI-5005	BA681344	
Repeat Switch P.C Board Comp. CI-5036	BA681930	
Door Switch P.C Board Comp. CI-5026	BA681311	
EQ. P.C Board Comp. CI-5028	BA681298	
Rec, PB Combination Head PR4-2	HP671174	Same as GXC-325D, GXC-740D, GXC-760D
Erase Head E4-165	HE636963	Same as GXC-325D, GXC-740D, GXC-760D
Head Base Block Comp.	BH211105	
Push Button Knob J	SK634410	
Push Button Knob I	SK631304	
Dolby Knob CI-6027	SK691312	
Selector Knob CI-6020	SK691288	
Adjustment Knob CI-6021	SK691290	
Knob 1 (Rec Level) CI-6022	SK694710	
Knob 2 (Output) CI-6023	SK694721	
Memory Cap A AA-5521	SK665223	
Volume VM10E076 1 kB	EV691391	
Volume VM10R840 5 kB	EV691380	
Volume VM10E050 5 kB	EV691402	
Volume VJ10R670 50 kA	EV691468	

Parts Nomenclature	Parts No.	Note
Co-axial 2-throw Volume GJ70R519	EV691470	
Power Transformer CIT-1	BT699287	Switchable model
Power Transformer CIT-4	BT694822	CEE model
Power Transformer CIT-3	BT694811	CSA model
Power Transformer CIT-2	BT694800	JPN model
Relay LC1-C-JT DC24V	EP616500	
Relay MTS-2	EP621808	
Solenoid Plunger 1660THT2	EP537906	
Reel Table Block	BR670173	
VU Meter KL-250L-8	EM692583	
Main Motor SCM-700	BM681164	
Reel Motor GSM-300R	BM670140	Right Reel Motor
Reel Motor GSM-300L	BM670138	Left Reel Motor
Door Opening Motor RF-260-09400	BM692550	
Flywheel A CB-1018	BF667618	
Flywheel B CB-1018	BF669071	
Capstan Belt CB-1034	MB669036	
Pinch Roller	MP612628	
Counter Belt CI-1014	MB690390	
Counter SMP-390-86	MC233021	
Steel Ball	MV522235	
MP Capacitor 6 μ F 150WV AC	EC412582	
Micro Switch SS-5GL	ES477966	
Micro Switch SS-5GL-13	ES494188	
Micro Switch VU-SR	ES691457	
Push Switch UEG-42L	ES691378	
Push Switch TV-3 JB52	ES469541	
Push Switch JS-09	ES499972	
Tape Switch A5056BD-H12	ES691323	
Push Switch UEG-22DE	ES419286	
Single Push Switch 1FS-8U-48	ES557908	
Lever Switch SLK04251	ES691424	
Rotary Switch SRE-273	ES691435	
Selector Box Block	BZ681131	
Dust Cover	BC694708	
Cylinder CI-6009	TC691187	
Damping Pin CI-6010	MH691198	
Door Key Block	BZ681186	

Parts Nomenclature	Parts No.	Note
Cassette Holder Block	BZ681952	
Touch Button Block	BK681232	
Fuse .1.5A 250V	EF563692	
Fuse 500mAT	EF593706	
Fuse 1AT	EF623103	
Fuse 250V 1.2A	EF668610	
Fuse 1.2A 250V	EF590692	
Door Open Block	BZ681300	
Lamp 8V 0.2A	EL295312	
Click Gear TW-5018	EZ535432	
Click Gear TW-5020	ZG535454	

7. List of Interchangeable Semiconductors

As far as service is concerned, in case the original parts cannot be obtained, the interchangeable parts listed below can be substituted.

Original Parts			Interchangeable Parts	
Description	Parts No.	Utilizing P.C Board	Description	Parts No.
2SA628(E)(F)	ET557976	CB-5004	2SA564(Q)(R) 2SA733(P)(Q)	ET538154 ET554657
2SB605(K)(L)	ET666415	CB-5004		
2SC458LG(C)	ET234854	CA-5205	2SC458(C) 2SC693U(F) 2SC1312S(G)(H)	ET329218 ET315472 ET603257
2SC945L(P)	ET638504	CI-2012 CI-5028 CB-2026	2SC711(E)(F) 2SC1641(R)(S)(E) 2SC1647(R)(S)(E)	ET453486 ET603843 ET623733
2SC945L(Q)(P)	ET639437	CI-5030 CI-5005 CI-5029 CI-5036		
2SC945L(Q)(R)	ET398711	CI-2012 CB-5004 CI-5028 CA-5205		
2SC1175(E)(F)	ET622080	CI-5030	2SC1211(E)(F)	ET666393
2SC1211(E)(F)	ET666393	CB-5004	2SC1175(E)(F) 2SC1247A(B)(V)	ET622080 ET511920
2SC1222(E)(F)	ET469810	CA-5205	2SC458LG(C) 2SC1000GR(BL)	ET234854 ET622181
2SC1647(S)(E)	ET592424	CI-2020	2SC536(F)(G)(H) 2SC945L(K)(P)(Q)	ET632215 ET632204
2SC1683(P)(Q)	ET635826	CI-5030	T1P47 T1P48	ET621775 ET621786
2SD360(D)(E)	ET517375	CB-5004	2SC1098(L)(K) 2SD325(D)(E)	ET465208 ET631855
2SD361(D)(E)	ET537300	CI-5030	2SC1098(L)(M)	ET476886
2SD401(K)(L)	ET666707	CB-5004		
2SD571(K)(L)	ET666404	CB-5004 CI-5030		
2SD571(L)(M)	ET650553	CI-5026		

Original Parts			Interchangeable Parts	
Description	Parts No.	Utilizing P.C Board	Description	Parts No.
2SK30A(D)	ET645917	CA-5205		
2SK30A(GR)	ET491051	CI-2012		
2SK68A(L)(M)	ET669633	CA-5205	2SK34(D)	ET603270
μ PC1023H	EI669666	CA-5205	TA7122P	EI669712
μ PC1024H	EI669655	CA-5205	TA7129P	EI657000
TA7122AP	EI669712	CA-5205		
DN-835	EI620640	CB-2026		
1N34A	ED219464	CA-5205 CB-5004	1N60 1S188AM	ED428264 ED562386
1S2473 1S2473VE	ED624903 ED560913	CA-5205 CB-5004 CI-2006 CI-5036 CI-5005 CI-5030 CI-2012 CI-2020 CI-5029 CI-5028 CI-5026	1S1588 WG599 WG713	ED557447 ED514721 ED515790
WZO85	ED491130	CA-5205	RD9A	ED384096
1OD05	ED494583	CI-5030	1N4001	ED538615
1OD2	ED224548	CI-2020	1N4003	ED570295
1OD4	ED224550	CB-5004	1N4004	ED570273

NOTE: The electrical characteristics of diodes 1S2473 and 1S2473VE are exactly the same. VE indicates "Vertical Type".

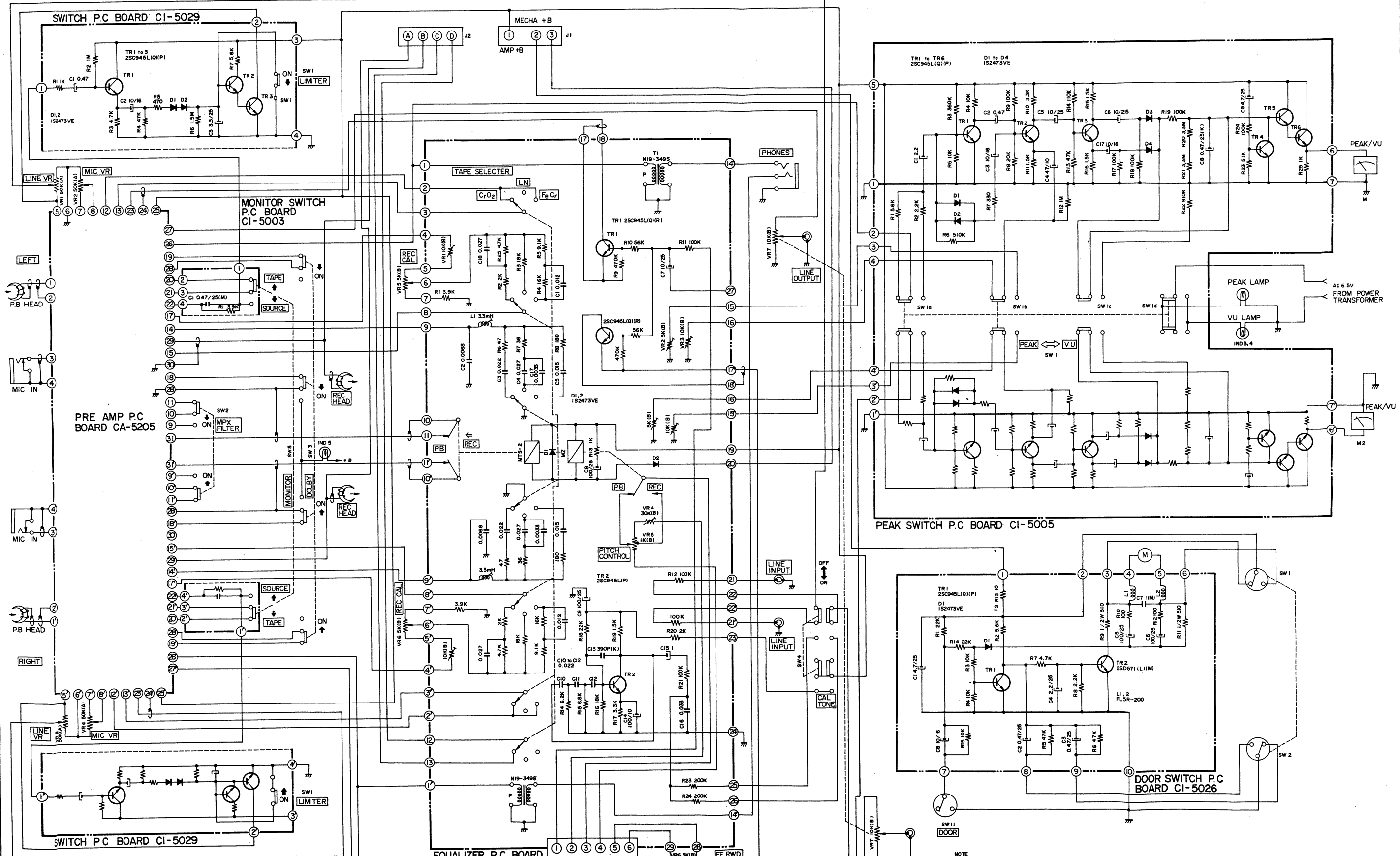

NOTE
 1. UNLESS OTHERWISE SPECIFIED
 ALL RESISTORS IN OHMS 1/4 W (J)
 ALL CAPACITORS IN μ F 50WV (J)
 2. FS = FAIL SAFE RESISTORS

GXC-570D AMP
 CONNECTION DIAGRAM
 NO. 3-1 1521626A

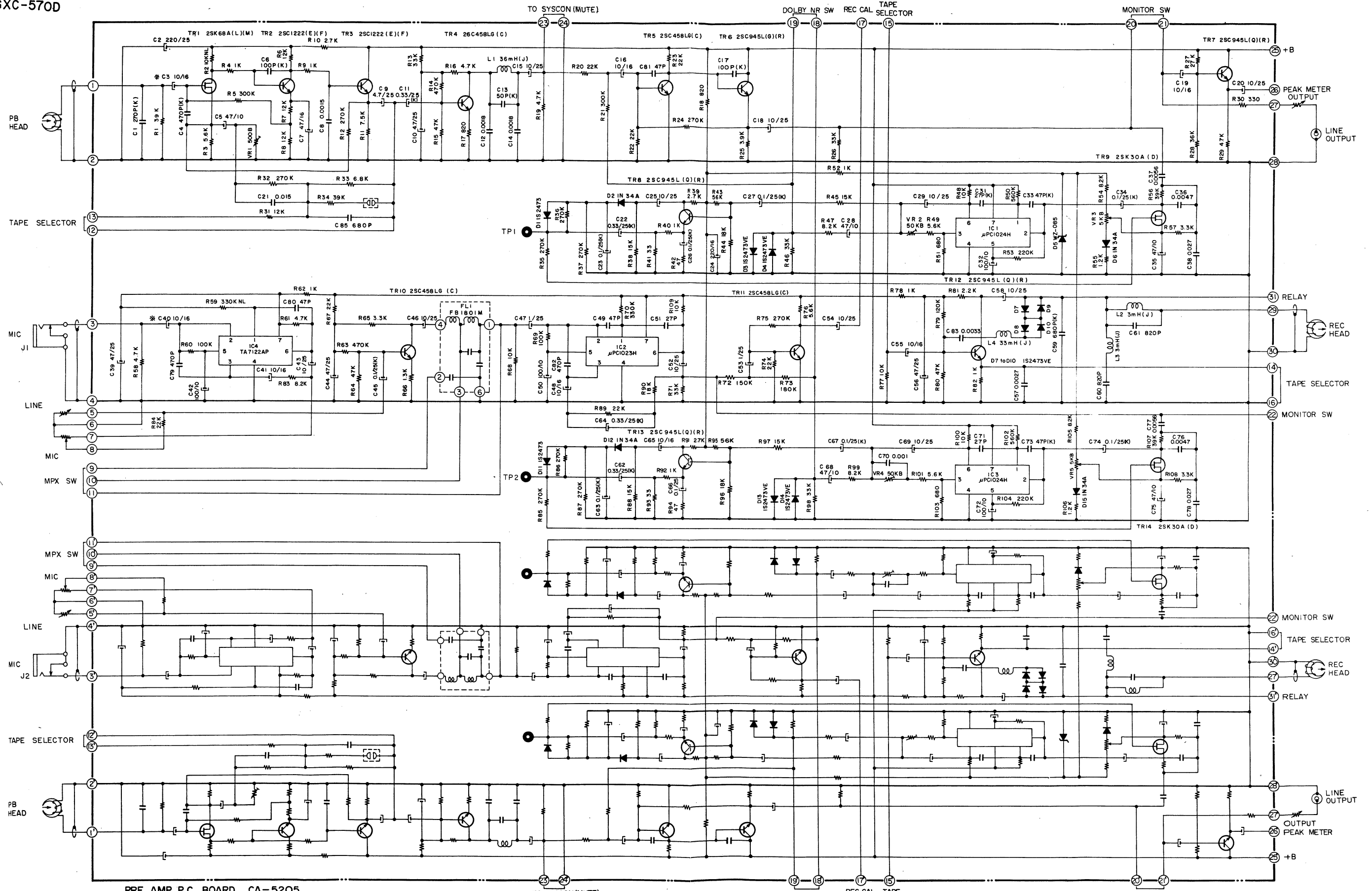

NOTES
 1. UNLESS OTHERWISE SPECIFIED
 ALL RESISTORS IN OHMS 1/4(J)
 ALL CAPACITORS IN uF 50WV(J)
 2. * MARK INDICATES LOW LEAKAGE
 CAPACITORS
 3. NL INDICATES NOISE LESS RESISTORS

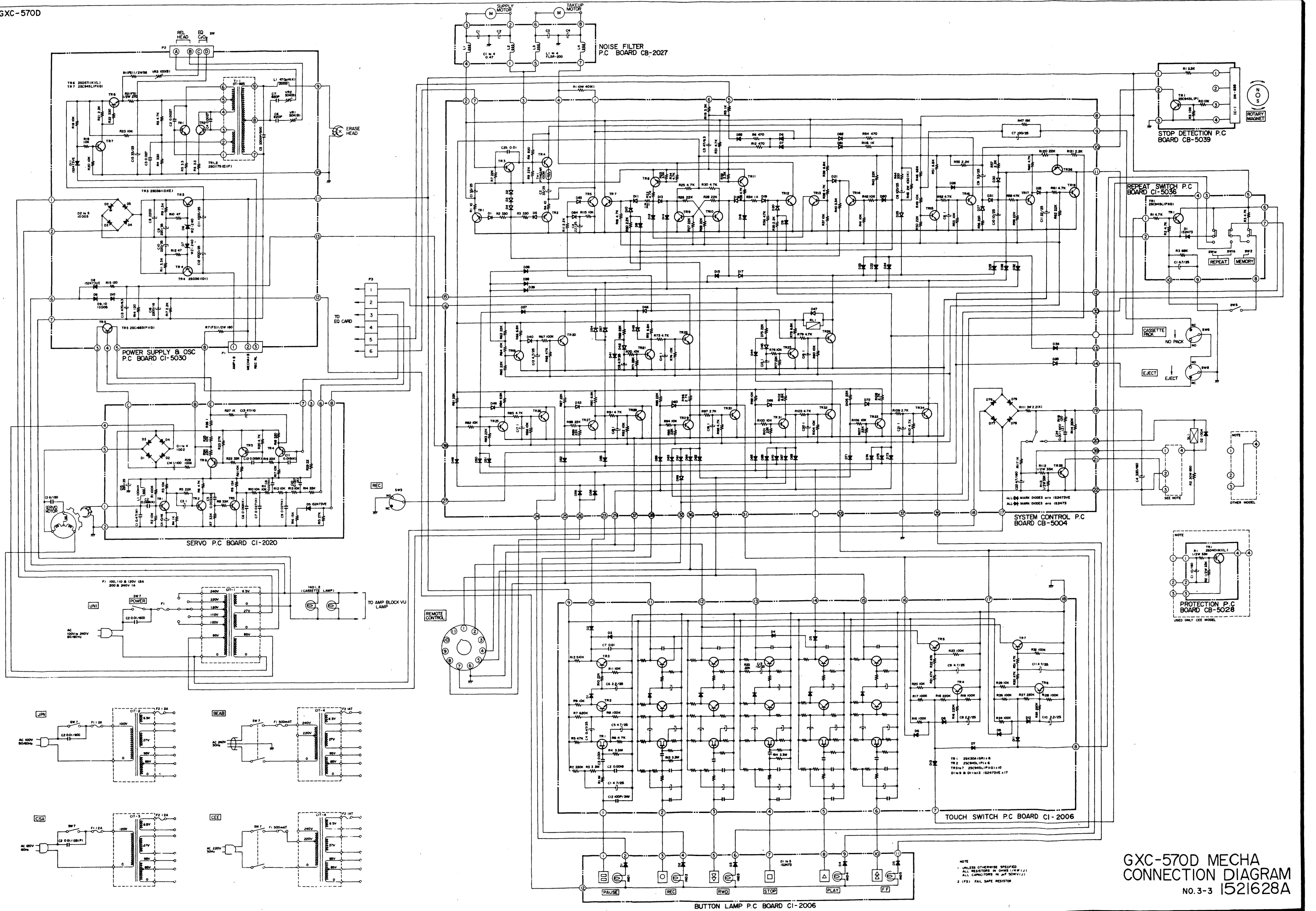

GXC-570D MECHA CONNECTION DIAGRAM
NO. 3-3 1521628A