

AKAI

Reference Master

GX-95

STEREO CASSETTE DECK

OPERATOR'S MANUAL (5)

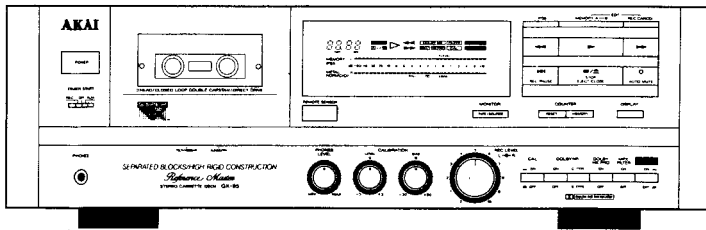

To assure optimum performance and listening enjoyment, please read this operator's manual thoroughly.

* Cassette tapes shown in the illustrations are not standard accessories.

English.....	Page	1—28
Français.....	Page	29—56
Deutsch.....	Seite	57—84
Nederlands.....	Pagina	85—112
Español.....	Página	113—140

Precautions and table of contents

2

WARNING

To prevent fire or shock hazard, do not expose this appliance to rain or moisture.

1-En

Power requirements

Power requirements for electrical appliances differ from area to area. Please ensure that your unit meets the requirements in your area.

If in doubt, consult a qualified electrician.

120 V, 60 Hz for USA and Canada

220 V, 50 Hz for Europe except UK

240 V, 50 Hz for UK and Australia

110 V/120 V/220 V/240 V, 50/60 Hz convertible for other countries.

Voltage conversion (Not on all models)

Models for Canada, USA, Europe, UK and Australia are not equipped with this facility.

Each unit is preset at the factory according to its destination, but some units can be adjusted to 110 V, 120 V, 220 V or 240 V as required.

If your unit's voltage can be converted:

Before connecting the power cord, turn the VOLTAGE SELECTOR located on the rear panel with a screwdriver until the correct voltage is indicated.

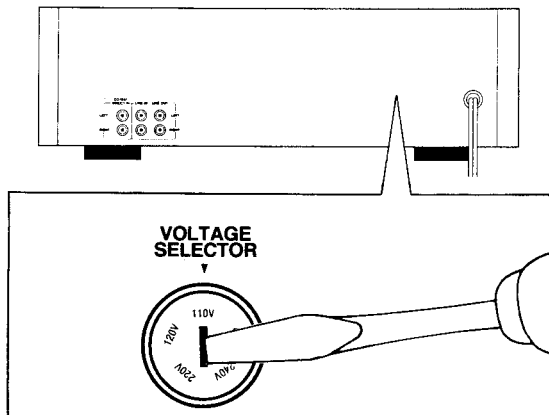

2-En

This equipment conforms to No. 82/499/EEC standard.

3-En

What you should know to protect yourself

- Never touch the plug with wet hands.
- Always pull out by the plug and never the cord.
- Only let a qualified professional repair or reassemble the stereo cassette deck. An unauthorized person might touch the internal parts and receive a serious electric shock.
- Never put anything, especially metal, into the stereo cassette deck.

Protect the stereo cassette deck too

- Use only a household AC power source. Never use a DC power source.
- If water is spilled on the stereo cassette deck, disconnect it and call your dealer.
- Make sure that the stereo cassette deck is well ventilated and away from direct sunlight.
- To avoid damage to the internal circuits and the external surface, keep it away from heat (stoves, etc.).
- Avoid using spray type insecticide near the stereo cassette deck. It can damage the finish and might ignite suddenly.
- To avoid damaging the finish, never use paint thinner or other similar chemicals to clean the stereo cassette deck.
- Place the stereo cassette deck on a flat and solid surface.
- If you don't plan to use the stereo cassette deck for a long period of time, disconnect the power cord.

Dew formation

Dew is the term used for the formation of moisture on the very important tape transport sections such as the heads and the capstan, when the deck is used in places where humidity is high, or moved from a cold place to a warm one. If the deck is used when dew is present, the tape will stick to the head and be ruined, or it will not be transported properly. In that case, do not use the deck for approximately one hour until the deck is acclimatized.

Placement

If the cassette deck and tuner are placed on top of each other, humming noise may result during playback. Also beat noise may result during recording of AM broadcasts. In this case, the position of the deck should be changed. We recommend that the amplifier or a space the size of an amplifier be left between the deck and the tuner.

Table of contents

Precautions and table of contents.....	2—3
Connections.....	4
Before using your stereo cassette deck.....	5
Controls (Cassette deck).....	6—7
Controls (Remote control unit).....	8—9
Recording.....	10
Tape playback.....	11
For improved recordings.....	12—13
Recording calibration.....	12
Recording level adjustment.....	13
Monitor operation.....	13
Convenient recording features.....	14
Recording cancel.....	14
Spot erase.....	14
A little know-how goes a long way.....	15
Convenient playback features.....	16—18
IPSS.....	16
Repeat playback.....	17
Auto play.....	17
Headphone listening.....	17
Memory auto stop.....	18
Memory auto play.....	18
Timer controlled recording and playback.....	19
Operation details.....	20—23
CD/DAT DIRECT jacks connections and recording operation.....	20
To turn the FL display on and off.....	20
Recording with a microphone.....	20
The MPX (Multiplex) filter.....	21
Tape dubbing.....	21
Auto stop mechanism.....	21
Auto tape selector system.....	21
Tape counter.....	22
The peak level meter.....	22
Dolby NR system.....	22
Double process noise reduction system.....	22
Dolby HX PRO system.....	23
Cassette deck maintenance.....	24
Troubleshooting.....	25—26
Specifications.....	27
Features.....	27

Connections

4

Before beginning

- Turn off all the components before making connections.
- Connect everything securely. Loose connections can lead to malfunction.
- To prevent damage to the cords, connect and disconnect by holding the plug, not the cord.
- Make sure that you connect the white PIN-plugs to the left (L-white) jacks and the red PIN-plugs to the right (R-red) jacks.

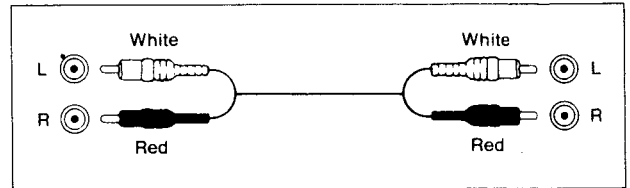

Connections

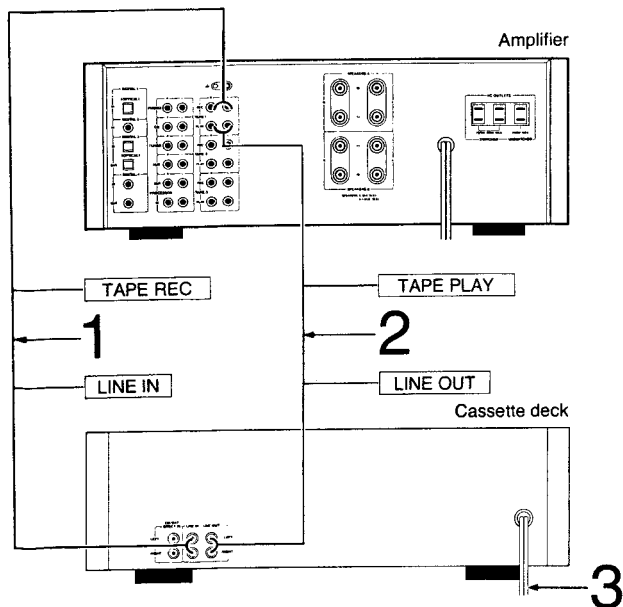
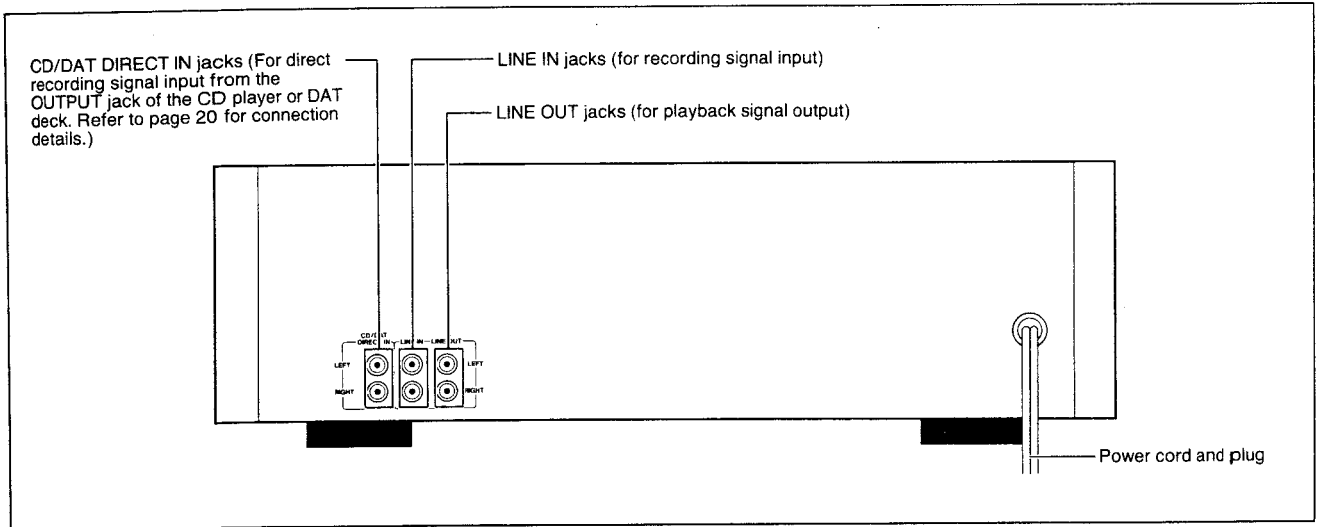

- 1 Connect the L (Left) and R (Right) LINE IN jacks of the cassette deck to the L (Left) and R (Right) TAPE REC jacks of your stereo amplifier with the provided connection cord.
- 2 Connect the L (Left) and R (Right) LINE OUT jacks of the cassette deck to the L (Left) and R (Right) TAPE PLAY jacks of your stereo amplifier with the provided connection cord.
- 3 **After you have connected everything** Connect the cassette deck's power cord to the AC OUTLET of your stereo amplifier, optional audio timer or directly to your household AC outlet.

Important

The illustrated power plugs and cords are intended for general reference. The power plug and cord used in your country may differ from the illustrations. (Example: U.K., Australia, U.S.A., Europe etc.)

25-En

Note

If your amplifier has 2 or more sets of TAPE jacks, the TAPE 1 REC and PLAY jacks are recommended for connections.

Before using your stereo cassette deck

How to load a cassette tape

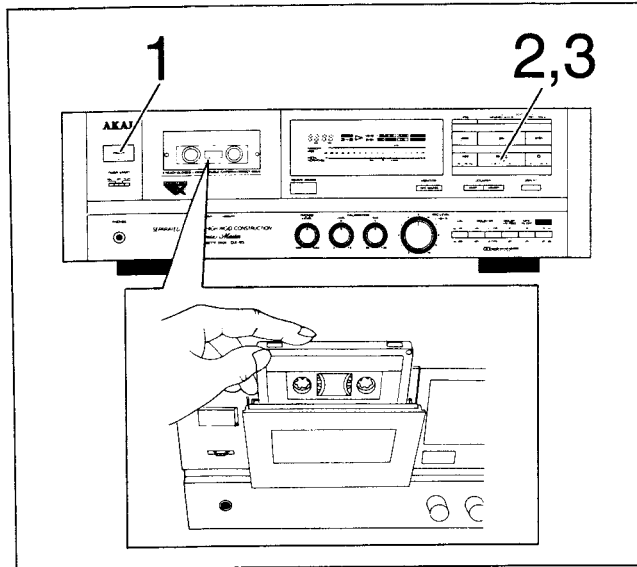

- 1 Press the POWER button to turn the power on. The FL display and cassette holder light will be turned on and the MIN and SEC indicators will flash on and off for a few seconds.
- 2 Press the $\blacksquare/\blacktriangle$ button to open the cassette holder and load a cassette tape. Insert exposed tape side down.
- 3 Press the $\blacksquare/\blacktriangle$ button again to close the cassette holder. The tape position of the loaded tape will appear on the FL display (METAL, CrO₂ or NORM).
 - * Pressing any tape operation button (except \bigcirc) will automatically close the cassette holder. Once closed, the deck will immediately go into the operation mode of the chosen button.
 - The cassette holder can also be closed by gently pressing it.

On the recording prevention system and recording defeat tabs

You can protect your tapes from accidental recording by removing the recording defeat tabs (one for each tape side) located above the A and B side indicators.

When the recording defeat tabs are broken, the recording prevention system will be automatically activated to protect the tape if the \blacksquare button is accidentally pressed during playback. To record over the pre-recorded cassette tape again, cover the holes with adhesive tape.

Note

Do not cover the tape position detecting holes as this will hinder proper operation of the auto tape selector.

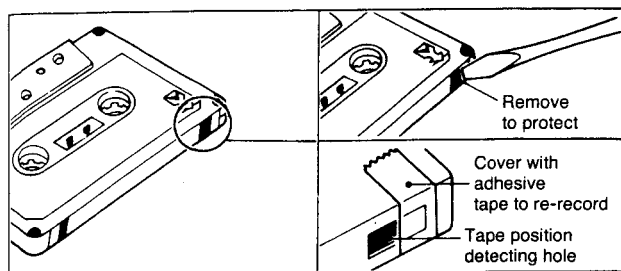

A Word about cassette tapes

Handling

- Do not touch the tape with your fingers as high frequency signals cannot be recorded in places which are not clean. Dirty tapes may also cause distortion or sound loss during playback.
- Do not leave the cassette tape near equipment which generates a magnetic field. (TVs, speaker systems, etc.)

Tape slack and leader tape advancement

Tape slack can cause the tape to twist or tangle around the capstan and pinch roller and ruin important recordings. Before using a cassette tape, take up tape slack with a pencil. Most cassette tapes include clear leader tape at the beginning. As recording is impossible on this leader tape, it should be advanced before recording is begun.

Storage

- Always put the cassette tape back into its plastic case after using it. Store it in a dry place, away from direct sunlight, heat (stoves, etc.) and equipment which generates a magnetic field (TVs, speaker systems, etc.).
- Store the cassette tape with the tape taken up at the fixed speed of recording or playback. When the tape is not taken up in an orderly manner (in other words, fast forwarded or rewound), the tape might stretch or warp.
- If you are not going to use the cassette tape for a long time, rewind or fast forward the tape once in a while. This is to prevent music signals from imprinting themselves over other music signals when tape surfaces are in close contact for a long time. Rewinding or fast forwarding the tape also prevents moisture condensation.

Regarding cassette tapes

- We recommend the use of cassette tapes specifically made for recording hi-fi music.
- We do not recommend the use of C-120 (120 minute) cassette tapes. The tape is very thin and can easily twist or tangle around the capstan and pinch roller.
- We do not recommend the use of cassette tapes of poor quality. You will not be able to fully utilize the capability of your stereo cassette deck with this type of cassette tape.
- We do not recommend the use of ferri-chrome cassette tapes for recording.

Controls (Cassette deck)

6

On the FL (FLuorescent) display

The FL display can be turned on and off by pressing the DISPLAY button on the front panel.

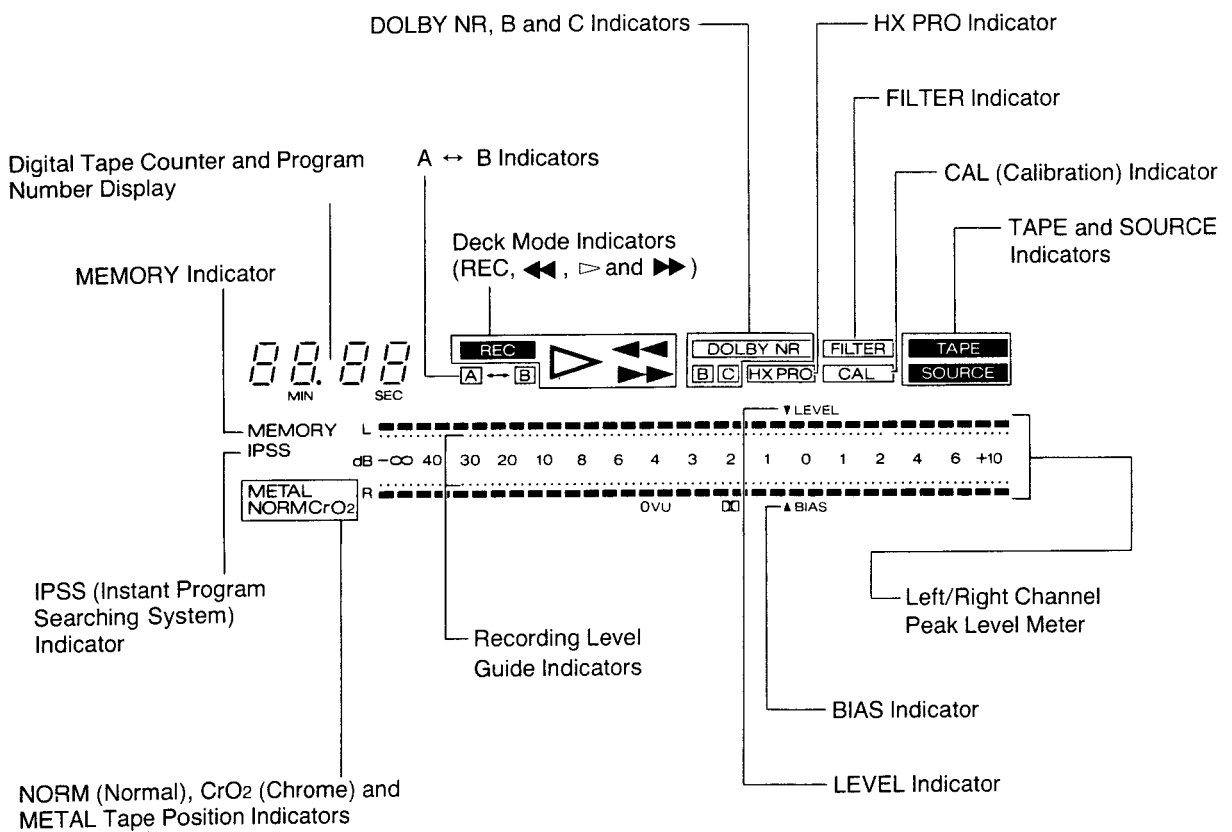

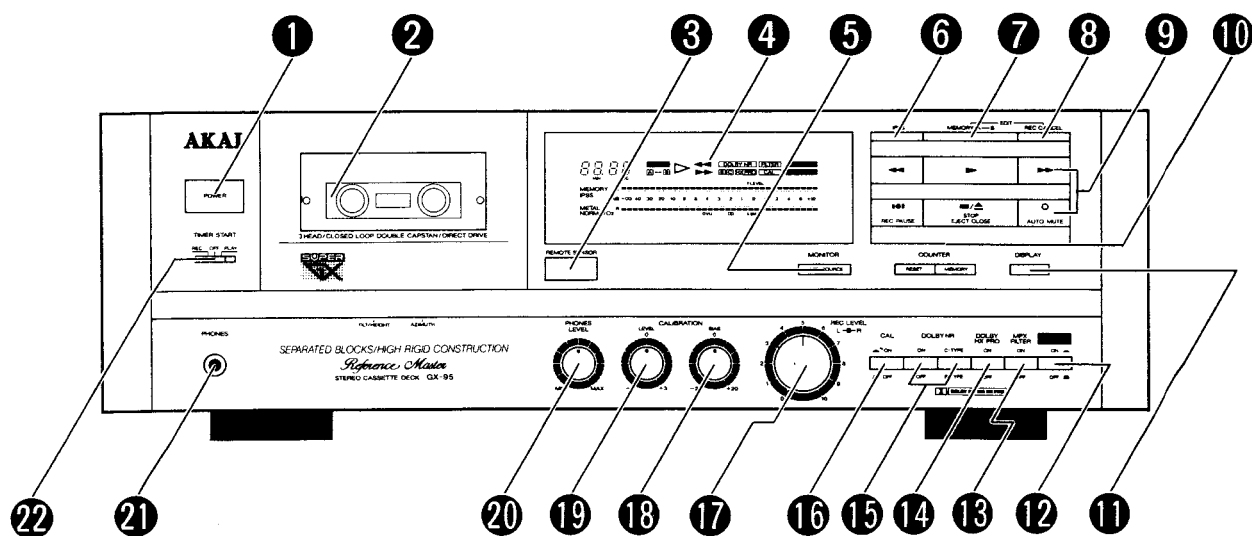

- 1 POWER button**
To turn the power on and off.
- 2 Cassette Lid and Holder**
Load a cassette tape here.
To open and close the holder, press the $\blacksquare/\blacktriangle$ button.
- 3 REMOTE SENSOR Window**
For reception of the remote control signal from the provided RC-G95 remote control unit.
Keep away from strong light and direct sunlight as this will interfere with the remote control function.
- 4 FL Display**
Tells you what the cassette deck is doing.
- 5 MONITOR Button (TAPE/SOURCE)**
To select between TAPE and SOURCE monitor modes.
This button is incorporated with an auto monitor system.
- 6 IPSS (Instant Program Searching System) Button**
To turn the IPSS on and off.
- 7 MEMORY A \leftrightarrow B Button**
To memorize the repeat playback intervals for 2-point repeat playback or the erase intervals for the spot erase function.
- 8 REC CANCEL Button**
To erase the recorded program during recording or to cancel the memorized intervals for the spot erase function.
- 9 Operation Buttons (\ll : Rewind button, \blacktriangleright : Play button, $\blacktriangleright\blacktriangleright$: Fast forward button, $\bullet\bullet$: REC PAUSE button, $\blacksquare/\blacktriangle$: STOP EJECT/CLOSE button, \circ : AUTO MUTE button)**
To open and close the cassette holder, to start and stop recording and playback, to wind the tape and to engage the auto mute mode.
- 10 COUNTER RESET and MEMORY Buttons**
To reset the digital tape counter to the "00 min: 00 sec" position and to turn the memory system on and off.
- 11 DISPLAY Button**
To turn the FL display on and off.
- 12 CD/DAT DIRECT IN Switch (— ON/ — OFF)**
To select between input sources connected to the LINE IN or CD/DAT DIRECT IN jacks. For normal recording, set this button to — .
- 13 MPX FILTER Switch (— ON/ — OFF)**
To turn the multiplex filter on and off.
- 14 DOLBY HX PRO Switch (— ON/ — OFF)**
To turn the Dolby HX PRO system on and off. The Dolby HX PRO system will affect recording only when the button is set to — . Otherwise it is automatically defeated during playback.
- 15 DOLBY NR ON/OFF Switch and C-TYPE/B-TYPE Select Switch**
To turn the DOLBY NR system on and off and to select between B type or C type noise reduction for recording and playback purposes.
- 16 CAL (Calibration) Switch (— ON/ — OFF)**
To turn the recording calibration system on and off.
- 17 REC LEVEL Controls (LEFT \rightarrow RIGHT)**
To set the recording input level. The outside knob is for left channel level control and the inside knob is for right channel level control. For normal stereo recording the red lines should be set to the same position.
- 18 BIAS CALIBRATION Control**
To adjust the recording bias current during recording calibration.
The bias adjustment range is between -20% and $+20\%$ of the proper bias current for Normal, CrO₂ and Metal position tapes. Normally set the control to the center click "0" position.
- 19 LEVEL CALIBRATION Control**
To adjust the recording sensitivity level during recording calibration.
The recording sensitivity level adjustment range is between -3% and $+3\%$ of the proper recording sensitivity level for Normal, CrO₂ and Metal position tapes. Normally set the control to the center click "0" position.
- 20 PHONES LEVEL Control**
To adjust the output level of the PHONES jack.
- 21 PHONES Jack**
For headphone connection.
- 22 TIMER START Switch (REC/OFF/PLAY)**
To select operation of the timer start function when the power is turned on.

Controls (Remote control unit)

8

The remote control unit includes many of the operation buttons found on the cassette deck and can be used to conveniently control most of it's functions.

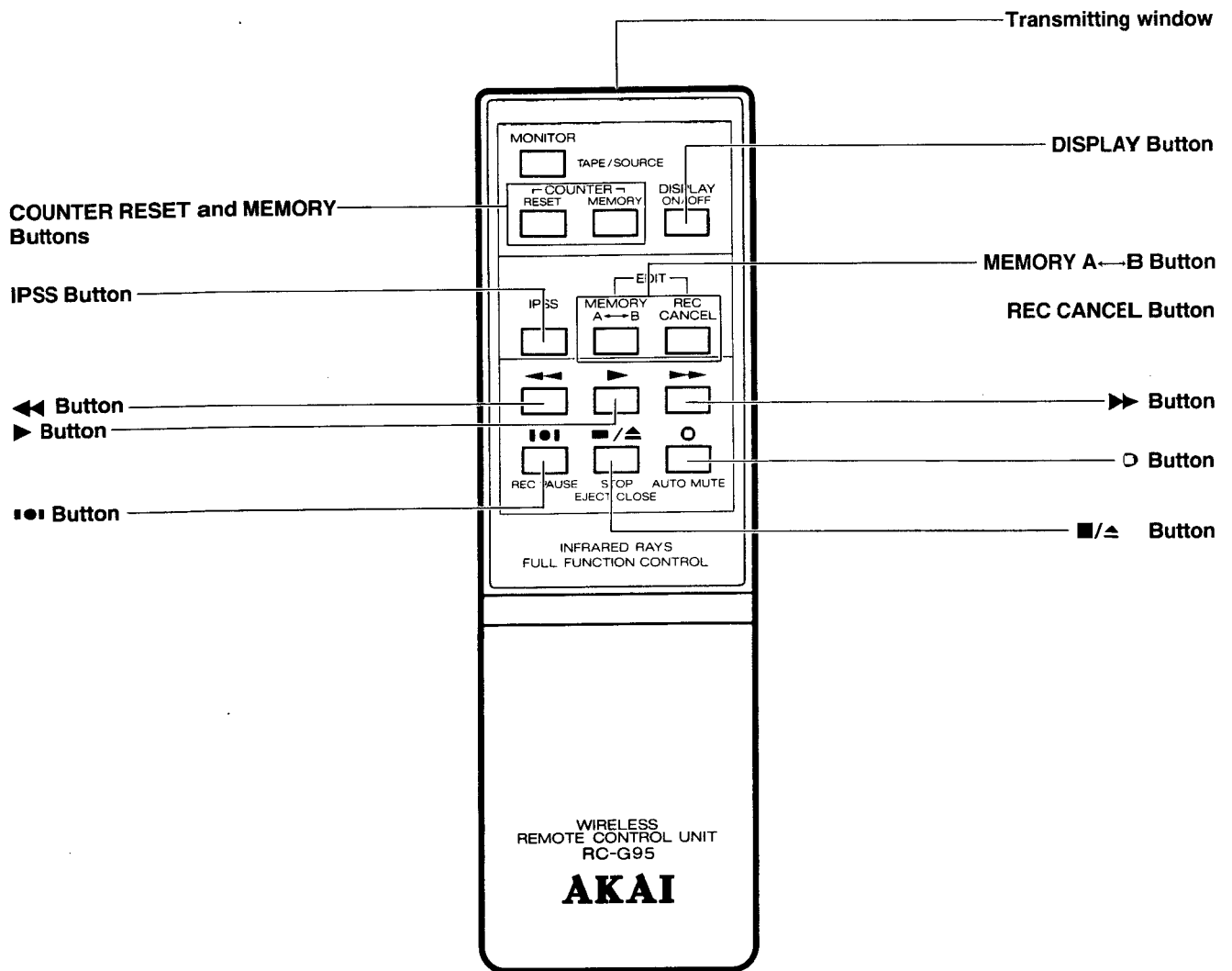

Operation

Point the remote control unit at the REMOTE SENSOR window, and press the desired operation button.

If the remote control unit will only operate from a short distance or narrow angle, this indicates that the battery voltage is low. Replace all the batteries with new ones.

When replacing the batteries, clean all the remote control and battery terminals with a dry cloth.

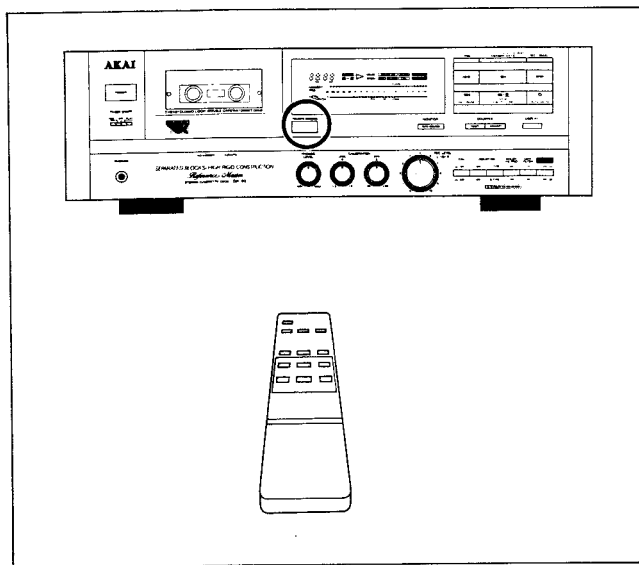

How to load the batteries

Use UM-3, SUM-3, AA size, R6 or equivalent sized batteries for the remote control unit.

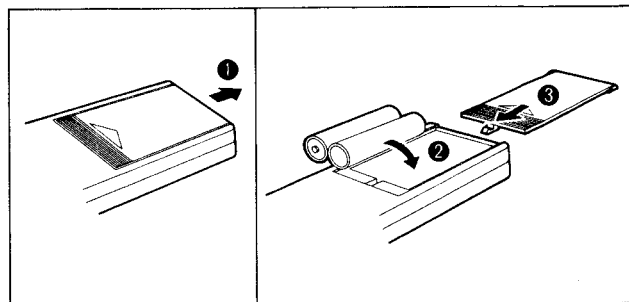

- 1 Remove the battery compartment cover by depressing the lever and pulling it up.
- 2 Load the batteries according to the markings on the remote control unit.
- 3 Replace the battery compartment cover.

Cautionary notes

On the remote control unit

- Avoid dropping the remote control unit or getting it wet.
- Avoid exposing the remote control unit to direct sunlight or strong light as this may cause malfunction.
- Do not use re-chargeable batteries.

On the dry batteries

- Refer to the markings on the remote control unit for the correct batteries.
- When you do not plan to use the remote control unit for a long period of time, remove the batteries.
- Read the cautions printed on the batteries before using them.
- Insert the batteries matching their polarity guides with those in the remote control battery compartment.
- When replacing the batteries, replace them all at the same time. Do not mix up old batteries with new ones.

Recording

10

Before beginning

- Set the TIMER START switch to OFF.
 - Set the CAL and CD/DAT DIRECT switches to **▲**.
 - Set the MPX FILTER switch to **▲** for normal recording purposes.
 - Turn on the power of all the components.
After the power is turned on, the operation buttons cannot be used for a few seconds while the cassette deck stabilizes itself.
 - Select the recording source with the amplifier's input selector or the recording output selector.
- Check the cassette tape being used for recording. Make sure the recording defeat tabs are intact and that the tape's recording time is of sufficient length.

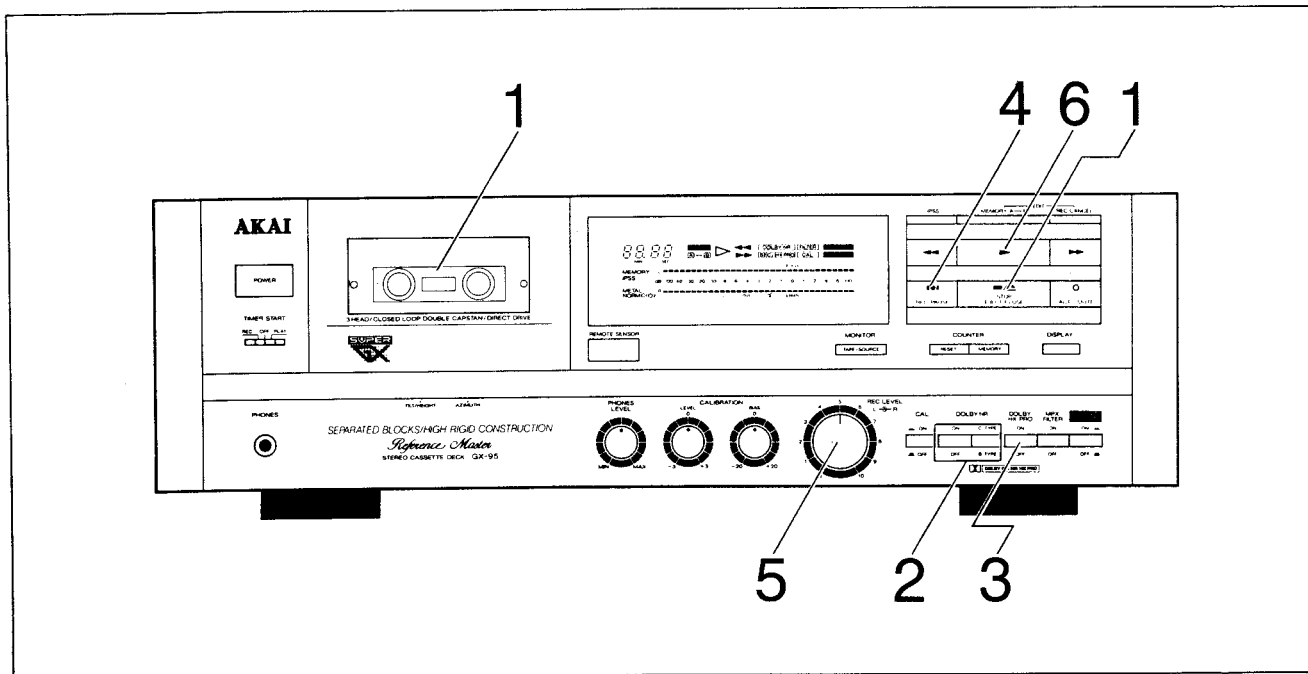

Operation

- 1 Press the **■/▲** button and load a cassette tape. Insert exposed tape side down.
- 2 Set the DOLBY NR ON/OFF and C-TYPE/B-TYPE select switches as follows:
 - Recording with DOLBY C-type NR.....
Set the DOLBY NR ON/OFF switch to **▲** and the C-TYPE/B-TYPE select switch to **▲**.
 - Recording with DOLBY B-type NR.....
Set the DOLBY NR ON/OFF switch to **▲** and the C-TYPE/B-TYPE select switch to **■**.
 - Recording without Dolby NR.....
Set the ON/OFF switch to **■**.
- 3 Set the DOLBY HX PRO button to **▲** for better recording results.
- 4 **Standby for recording**
Press the **●●●** button.
The cassette deck will go into the recording standby mode and the MONITOR switch will be automatically set to SOURCE.
The REC and SOURCE indicators will light and the **▷** indicator will flash on and off.
- 5 **Recording level adjustment**
Test play the source and set the recording level with the REC LEVEL controls.
The standard recording level should not exceed the end of the recording level guide on the peak level meter.

- 6 **To start recording**
Press the **▶** button.
The **▷** indicator will stay lit and the SOURCE indicator will be replaced by the TAPE indicator.

The cassette deck will stop automatically when the end of the tape is reached. The deck mode indicator will disappear and the TAPE indicator will be replaced by the SOURCE indicator.

To stop recording
Press the **■/▲** button.

To stop recording temporarily
Press the **●●●** button during recording.
The **▷** indicator will flash on and off and the TAPE indicator will be replaced by the SOURCE indicator.

To resume recording
Press the **▶** button.

Notes for recording

- Set the BIAS and LEVEL CALIBRATION controls to their center click "0" positions for normal recording. Refer to page 12 for operation details.
- Set the CD/DAT DIRECT IN button to **▲** before recording from the CD/DAT DIRECT IN jacks. Refer to page 40 for operation details.

Tape playback

Before beginning

- Set the TIMER START switch to OFF.
- Set the CAL and CD/DAT DIRECT buttons to .
- Set the MPX FILTER switch to .
- Turn on the power of all the components.
After the power is turned on, the operation buttons cannot be used for a few seconds while the cassette deck stabilizes itself.

- Set the amplifier's input selector to the TAPE position.
- Check the cassette tape being used for recording. Make sure the recording defeat tabs are intact and that the tape's recording time is of sufficient length.

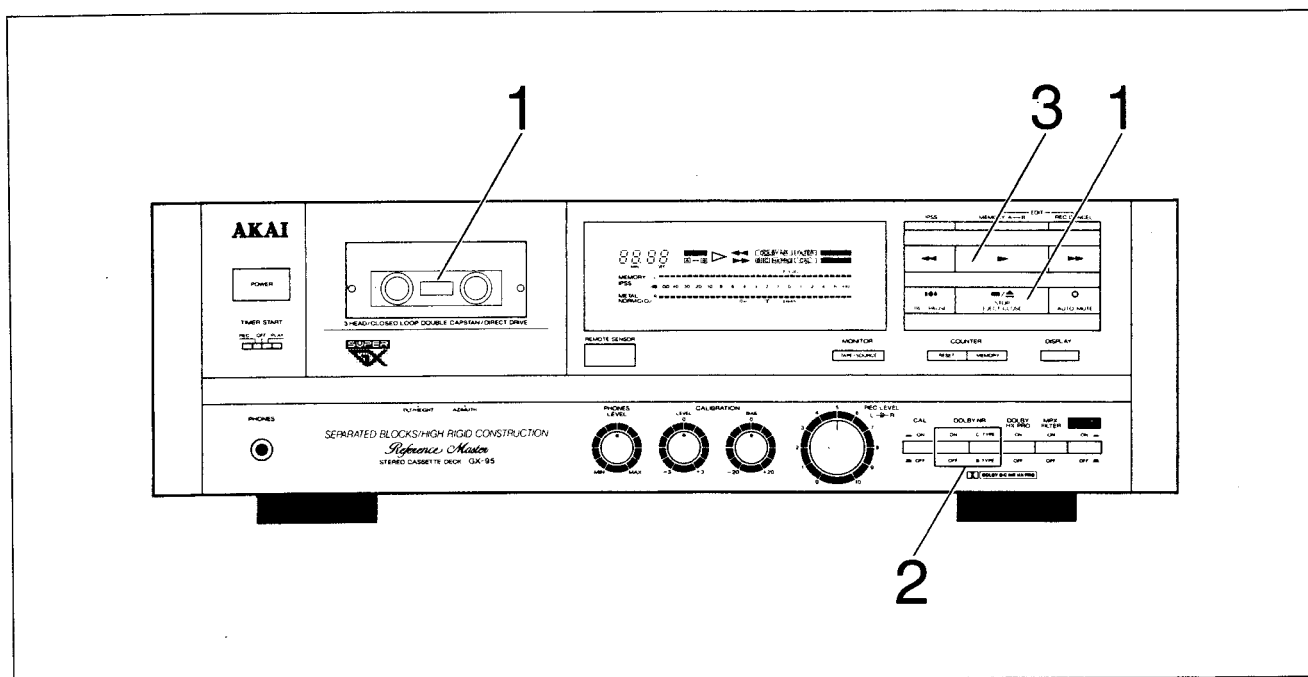

Operation

- 1 Press the /▲ button to open the cassette holder and load the cassette tape. Insert tape exposed side down.
- 2 Set the DOLBY NR ON/OFF and C-TYPE/B-TYPE select switches according to how the tape was recorded:
 - Tapes recorded with DOLBY C-type NR Set the DOLBY NR ON/OFF switch to and the C-TYPE/B-TYPE select switch to .
 - Tapes recorded with DOLBY B-type NR Set the DOLBY NR ON/OFF switch to and the C-TYPE/B-TYPE select switch to .
 - Tapes recorded without Dolby NR Set the ON/OFF switch to .
- 3 **To start playback**
Press the ▶ button. The ▶ and TAPE indicators will appear on the FL display and playback will begin.

The cassette deck will stop automatically when the end of the tape is reached.

To stop playback
Press the ■ button. The deck mode indicator will go off.

To wind the tape quickly
To wind the tape to the end
Press the ►► button. The ►► indicator will light up while the tape is winding.

To rewind the tape to the beginning
Press the ◀◀ button. The ◀◀ indicator will light up while the tape is rewinding.







Press the ▶ button to start playback from the fast forward or rewind modes or press the ■/▲ button to stop the tape.

Note
● During playback, the DOLBY HX PRO system will be defeated automatically if the DOLBY HX PRO switch is set to .

For improved recordings

12

Recording calibration : Calibrating the loaded cassette tape

- 1 Load the cassette tape for recording.
- 2 Set the CAL switch to . The calibration signal will be supplied and the peak level meter will be replaced by the BIAS and LEVEL calibration indicators.
- 3 Press the  button and the  button simultaneously to start recording calibration. The calibration level meter will appear on the FL display.
- 4 Turn the BIAS CALIBRATION control toward the left or right until the level meter does not exceed the BIAS indicator.
- 5 Turn the LEVEL CALIBRATION control toward left or right until the level meter does not exceed the LEVEL indicator.
- 6 Repeat steps 4 and 5 until the proper bias and level is adjusted.
- 7 Press the REC CANCEL button to cancel the calibration signal. The calibrated section of the tape will be rewound and the deck will go into the recording standby mode automatically.
- 8 Set the CAL switch to . The calibration level meter will be replaced by the peak level meter and the cassette deck will go into the stop mode automatically. Press the  and  button to start recording.

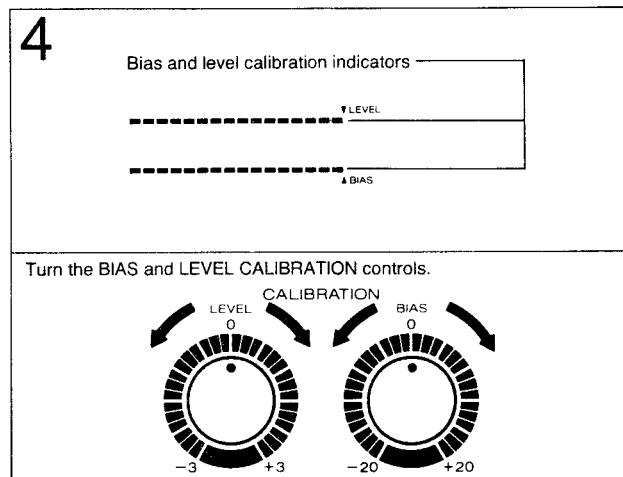
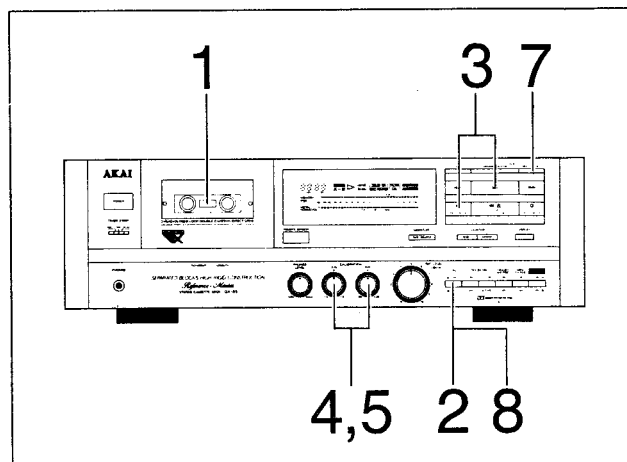

Cassette tape and recording calibration



Cassette tapes can be separated widely into 3 types; Normal position, Chrome (CrO₂) position and Metal position. Recording characteristics vary slightly, even with tapes that have the same tape position.

For good recording results, precise adjustment of the tape's bias current and sensitivity level is necessary.

Calibration improves the performance of the cassette tape and noise reduction system being used.

This cassette deck calibrates the bias current and sensitivity level according to the loaded cassette tape. Calibrating the sensitivity level to its optimum level helps the noise reduction system to operate accurately and effectively during recording. If the bias and sensitivity levels of the cassette deck are not set properly, the recorded sounds will include some coloration and loss of maximum output levels (MOL) at high frequencies and the noise reduction system will not operate properly.

Notes for calibration

- For standard bias and sensitivity level calibration, set both the BIAS and LEVEL CALIBRATION controls to their center positions.
- If the tape is not rewound after calibration, recorded calibration signals will be left on the tape.
- Be sure to Set the CAL switch to  after calibration.
- If you change cassette tapes during recording, repeat the calibration operation for the newly loaded cassette tape.
- The noise reduction system is defeated while the CAL switch is set to .
- After calibration is finished and recording has begun, do not adjust the BIAS or LEVEL CALIBRATION controls.
- The BIAS and LEVEL CALIBRATION controls are ineffective during playback.
- Pressing the CAL switch cancels all other tape operations. The cassette deck will go into the stop mode if the CAL switch is pressed when the cassette tape is running.

Recording level adjustment

Basic recording level adjustment

Basically, adjust the REC LEVEL controls so that the recording level does not exceed the recording level guide indicators on the peak level meter when the cassette deck is in the tape monitor mode (the TAPE indicator will be on the FL display).

The recording level guide indicators will vary according to the tape position of the loaded tape.

Recording Level Balance

For normal stereo recording, make sure the red lines on the Left and Right REC LEVEL controls are aligned and then adjust both controls to the desired level at the same time. If necessary the Left and Right REC LEVEL controls can also be adjusted separately.

To decrease the right channel level:

Turn down the R REC LEVEL control.

To decrease the left channel level:

Turn down the L REC LEVEL control.

Recording level adjustment example

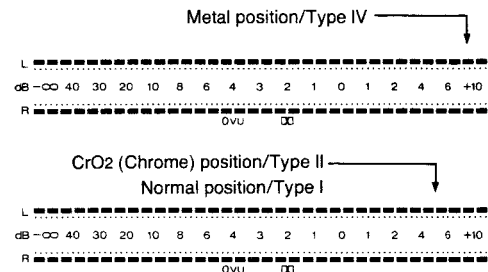

To make better recordings

To make better recordings, the recording input levels must be correct.

The recording input levels should be set as high as possible, without exceeding the recommended levels indicated on the peak level meter. If the recording levels are too high, distortion will result. If the input levels are too low, noise such as tape hiss will become noticeable. Make certain that the recording input levels match the maximum saturation levels of the music source, which can be monitored on the peak level meter.

Monitor the input source signals by pressing the **MON** button before you begin recording (while you are test playing the music source). The recording level will be displayed on the peak level meter and can be adjusted accordingly with the REC LEVEL controls.

Monitoring : Comparing the source sound with the just-recorded sound during recording

Monitoring the source sound

Press the MONITOR button during recording.

The TAPE indicator will be replaced by the SOURCE indicator and the cassette deck will be set to the source monitor mode.

Monitoring the just-recorded sound

Press the MONITOR button again.

The SOURCE indicator will be replaced by the TAPE indicator and the cassette deck will be set to the tape monitor mode.

What is the auto monitor system?

The independent recording and playback heads in combination with two independent amplifiers (one for recording and another for playback) let you listen to a recording as it is being made. This is called tape monitoring. By switching the auto monitor system during recording, you can compare the just-recorded music (TAPE position) with the source music (SOURCE position). In this way you can make sure that you have set the recording input levels correctly. The tape monitor system of this cassette deck is called an "Auto Monitor System". Besides letting you manually set the tape monitor system, it also does it automatically. When the cassette deck is recording, the auto monitor system is set automatically to TAPE. During recording standby, it is automatically set to SOURCE.

Therefore, under normal circumstances there is no need for you to set the MONITOR switch yourself.

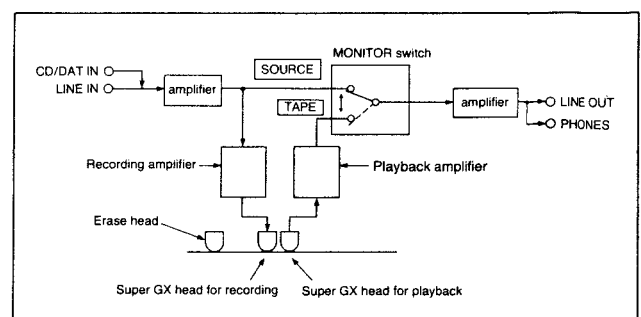

Notes for the auto monitor system

- After comparing sounds, set the cassette deck to the tape monitor mode by pressing the MONITOR button.
- The MONITOR switch is automatically switched between the source and tape monitor mode when operation buttons are pressed (the **▶** button for example).
- Set the tape monitor switch on your amplifier to the tape position before monitoring. Refer to your amplifier's operator's manual for tape monitoring operation.
- The MONITOR switch is automatically set to the tape monitor mode when the cassette deck's power is turned on.

Convenient recording features

14

Recording cancel : Canceling a section that has just been recorded.

Press the REC CANCEL button while the tape deck is in the recording mode.

The cassette deck will rewind the tape to the beginning of the section that has just been recorded, create a blank space and then standby for recording.

The REC indicator stays lit, the ► indicator flashes on and off and the TAPE indicator is replaced by the SOURCE indicator.

To resume recording

Press the ► button.

Notes

- In order for recording cancel to function properly, there must be 4 seconds or more of blank space at the beginning of the recorded section. To create blank spaces between selections, use the ○ button during the recording standby mode.
- After recording cancel has been performed, always make certain that you are at the beginning of the selection before re-recording.

Spot erase : Erasing part of a recorded program

Use the REC CANCEL and MEMORY A→B button if you wish to erase part of a recorded program.

Check before erasing the program

Make sure the recording defeat tabs of the cassette tape are not removed. The cassette deck will not go into the recording cancel mode if they are. Refer to page 5, "cassette tapes" for more details.

Operation

- 1 Press the ► button to start tape playback.
- 2 **Memorizing the starting point of the section to be erased**
Press the MEMORY A→B button once at the point you wish to begin the spot erase function.
The A→B indicator will flash on and off.
- 3 **Memorizing the end point of the section to be erased**
Press the MEMORY A→B button again when you reach the point at which you wish to end the spot erase function.
The A→B indicator will appear and the cassette deck will stop.
- 4 **To start erasure**
Press the REC CANCEL button to start the spot erase function.
The cassette deck will rewind the tape and begin erasing the recorded section between the two points you have programmed. When erasure is finished the cassette deck will stop automatically.

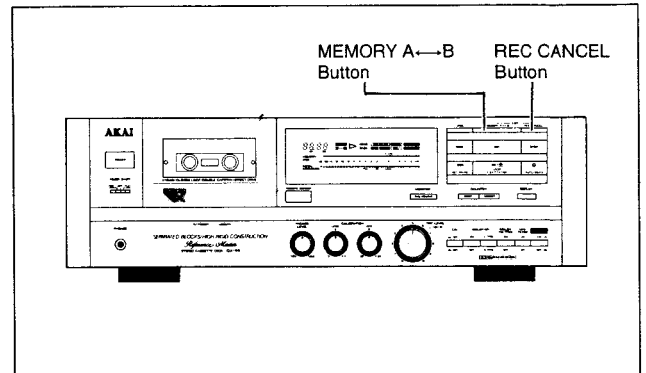

To confirm the portion to be erased (Before beginning erasure)

After operation 1,2 and 3, press the ► button for playback. The cassette deck will go into the repeat playback mode. After the memorized portion is played, the cassette deck will stop automatically.

After confirmation

Press the REC CANCEL button to start erasing. When the end of the section to be erased is reached, the A→B indicator will disappear and the cassette deck will stop automatically.

To cancel the spot erase function

Press the ■/▲ button.
The A→B indicator will disappear.

Erasing a short section of tape during playback

After playback has begun and you are near the portion of tape you wish to erase, depress the ► button for approx. 1 second. The cassette deck will go into the half speed playback mode. The ▷ indicator will flash on and off during half speed playback. Press the MEMORY A→B button and REC CANCEL button as in the previous procedures 2 to 4 to erase the desired section.

To resume normal speed playback during half speed playback

Press the ► button again.
The ▷ indicator will stay lit.

Notes

- Tape check: Before erasing the tape, take up slack with a pencil.
- When erasing tape in the half speed playback mode, confirmation of the portion to be erased can be made as in normal playback.
- During half speed playback, other functions such as recording, rewinding or fast forwarding cannot be used. The only button that will operate when pressed is the ■/▲ button used to stop the cassette deck.

A little know how goes a long way

1 Auto mute: To make a 4 second blank space during recording

With the  AUTO MUTE button you can automatically make a 4 second blank space between selections without adjusting the REC LEVEL controls.

During recording:

Press the  button **once** at the place you wish to make a blank space.

The cassette deck will go into the mute recording mode. The REC indicator will flash on and off.

After making a 4 second blank space, the deck will go into the recording standby mode and the  indicator will start flashing. The TAPE indicator will be replaced by the SOURCE indicator.

To resume recording

Press the  button.

The cassette deck will return to the normal recording mode. The SOURCE indicator will be replaced by the TAPE indicator.

To make a blank space of any length

The  button can also be used to make longer or shorter blank spaces or to erase long portions of tape.

During recording:

Press the  button **twice** at the place you wish to make a blank space.



The cassette deck will go into the mute recording mode.

The REC indicator will flash quickly.



To resume recording

Press the  button.

The cassette deck will return to the normal recording mode.



* If you wish to go to the recording standby mode first before entering the normal recording mode, press the  button before pressing the  button.

Note

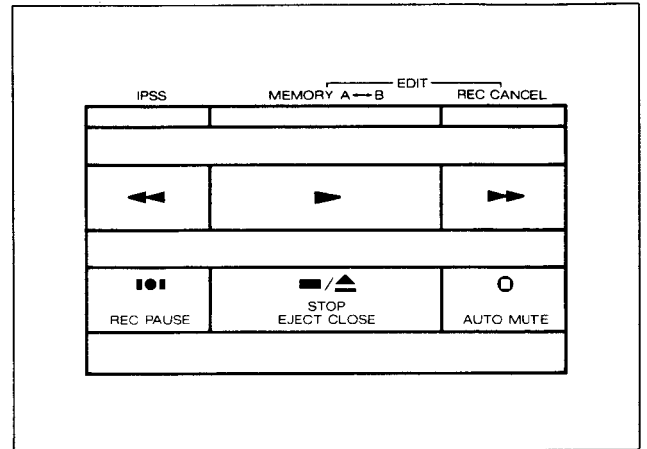

The mute recording function can also be used from the stop mode (to erase the beginning of a tape or for bulk erasing for example) by first pressing the  button. After this, press the  button once or twice depending on how long you wish mute recording to continue. Stop mute recording by pressing the  button.



2 To start recording immediately

Simultaneously press the  button and the  button. The REC and  indicators will light and the cassette deck will immediately go into the recording mode.

3 To go from playback to recording without stopping the tape

Simultaneously press the  button and the  button. The REC indicator will light and the cassette deck will go directly into the recording mode.

Convenient playback features

16

IPSS: Instant Program Searching System

IPSS can be used to directly locate and start playback from any recorded segment on the tape, within 16 segments of your starting point, in either the forward or reverse direction.

- 1 Press the IPSS button. The IPSS indicator will light up.
- 2 Press the ►► or ◀◀ button repeatedly until the number of the program you wish to start playback from is displayed on the digital display. When pressing the ►► or ◀◀ button, the digital counter display will be replaced by the program display. When locating a program in the forward direction 01, 02 etc., will be displayed on the program display and when locating a program in the reverse direction -01, -02 etc., will be displayed. The ▷ indicator will flash on and off while the tape is winding and the displayed number will decrease by 1 each time a blank space between selections (unrecorded section) is passed. When the chosen selection is found, the cassette deck will begin playback and the program display will be replaced by the digital tape counter.

- 3 **To cancel IPSS**
Press the IPSS button again. The IPSS indicator will go off. If IPSS is canceled while the tape is being wound, the cassette deck will continue winding the tape until the end.

If the selection is not found during IPSS operation

The cassette deck will continue searching to the end of tape is reached and stop automatically. The Program display will be replaced by the digital counter display.

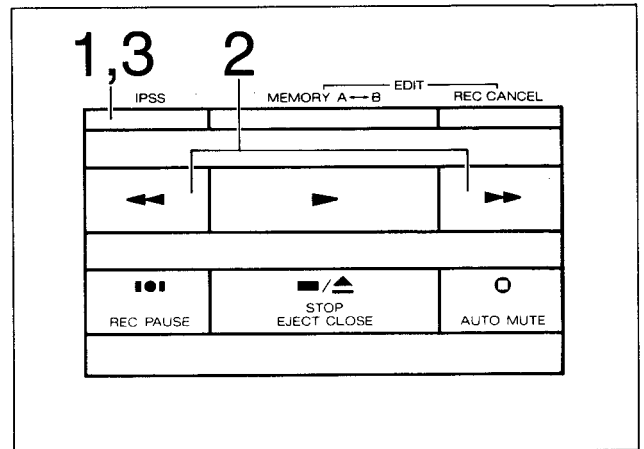

Notes for IPSS function

- IPSS detects low volume levels (blank spaces between selections) in order to determine when each selection begins and ends. When the music signals are below a specific volume level for a length of time which is more than approximately 4 seconds, that interval is detected as a blank space between selections.
- During classical music selections and music selections which have been recorded "Live", some parts may contain low signals for an interval of more than 4 seconds, and IPSS may detect this space as an interval between selections.
- During some "Live" recordings, there may be applause between the selections. Such intervals (which have a volume which is too high) will not be detected as blank spaces and will be skipped by the IPSS system.
- Pressing the ►► or ◀◀ button at the very beginning or end of a selection may cause malfunction of the IPSS function.
- IPSS is automatically defeated when the power is turned off.

Repeat playback : Repeated playback of a memorized section

By memorizing two points on the tape (beginning and end), you can repeat play back any section that you wish. This is ideal for times that you wish to listen to one particular section of a song repeatedly. One complete song or the whole tape can also be memorized for repeated playback. Use the MEMORY A↔B button as follows.

Operation

- 1 Start playback.
- 2 Press the MEMORY A↔B button to memorize the beginning (start) of the section you wish to playback repeatedly. The A↔B indicator will flash on and off.
- 3 Press the MEMORY A↔B button again to memorize the end of the section. The A↔B indicator will light and the cassette deck will stop automatically.
- 4 **To start repeat playback**
Press the ◀ button. The cassette deck will rewind the tape to the beginning of the memorized section and begin playback. Playback of the section will be repeated an infinite number of times.
- 5 **To stop and cancel repeat playback**
Press the ■/▲ button. The cassette deck will stop and the A↔B indicator will disappear.

Memorizing a few selections or the whole tape for repeated playback

After pressing the MEMORY A↔B button you can use the ▶▶ button or ◀◀ button to speed things up when memorizing a large section of tape. Once you are near the point you intend to end your memorized section, press the ▶ button to return to the normal playback speed. Memorize the end by pressing the MEMORY A↔B button again (The A↔B indicator will flash on and off until this is done). Press the ◀◀ button to rewind the tape and start repeat playback.

Auto play : Automatic playback from the beginning of a tape

Press the ◀◀ and ▶ buttons simultaneously. The ◀◀ indicator will light and the ▷ indicator will flash on and off when auto play is engaged.

The tape will be rewound to the beginning, and playback will begin automatically.

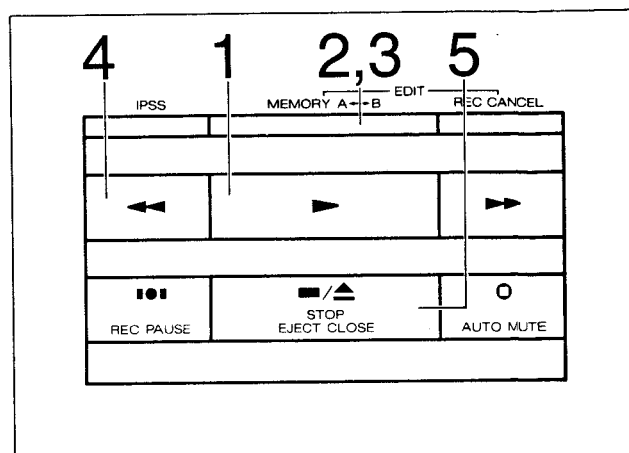

Notes on repeat playback

- If the ▶ button is pressed to start playback after memorizing a section of tape for repeat playback, the cassette deck will playback the memorized portion one time only, then automatically stop.
- Do not touch the REC CANCEL button after memorizing as this will erase the memorized section.
- The IPSS and memory system are automatically canceled during the memorizing operation.
- The memorized section will be canceled automatically when the power is turned off.

Headphone listening

- 1 Connect a pair of headphones to the PHONES jack.
- 2 Adjust the playback level with the PHONES LEVEL control.

Caution

Listening at high volume levels for long periods of time may damage your hearing.

Memory auto stop : Winding and stopping the tape at the "00:00" position of the tape counter automatically

- 1 Press the MEMORY button. The MEMORY indicator will light up.
- 2 Press the RESET button before recording, playback or at any point that you wish the tape to be wound to.
- 3 Press the ►► or ◀◀ button during recording or playback as follows;
 - To stop the tape from the fast forward mode
Press the ►► button.
 - To stop the tape from the rewind mode
Press the ◀◀ button.

When the "00:00" position of the digital tape counter is reached, the tape will be stopped automatically. If you wish to playback the tape press the ► button.

Notes

- The memory system will be defeated automatically if the IPSS button is pressed. The IPSS and memory systems cannot be used at the same time.
- The memory system will be defeated automatically while the recording cancel system is engaged.

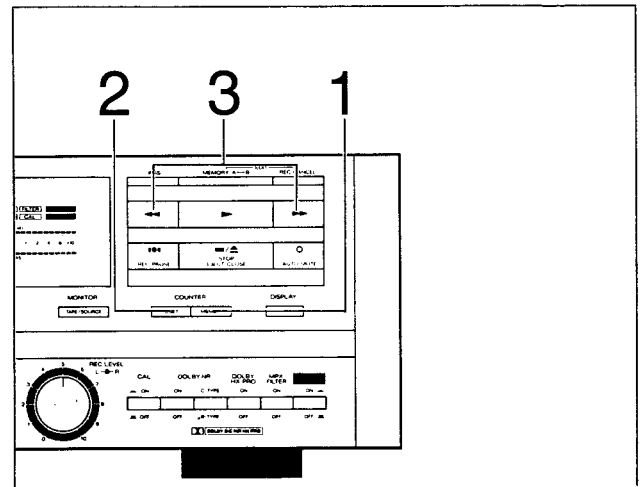

Memory auto play : Automatic rewind and playback from the "00:00" point on the tape counter

- 1 Press the MEMORY button. The MEMORY indicator will light up.
- 2 Press the RESET button to reset the counter to "00:00". Refer to procedure 2 above (memory stop).
- 3 Press the ◀◀ button and ► button simultaneously. The memory auto play system will be engaged. The ◀◀ indicator will light and the ► indicator will flash on and off while the tape is being wound.

When the tape reaches the "00:00" point on the tape counter, the cassette deck will start playback automatically.

Note

The memory auto play system will be engaged from the rewind mode only. It cannot be used from the fast forward mode.

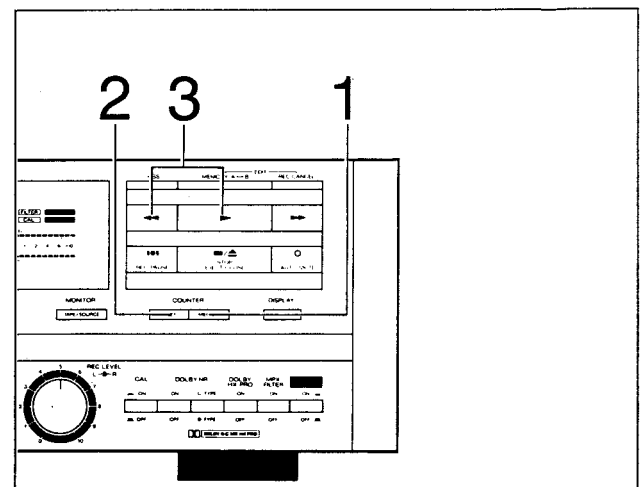

Timer controlled recording and playback

This cassette deck has a built-in timer start function. When used in combination with an optional audio timer, recording or playback can be started automatically at any programmed

time. Refer to the audio timer's operator's manual for operation details.

Timer controlled recording

After preparing for recording, set the timer to the timer operation mode. The connected audio components will be turned off automatically.

Set the cassette deck's TIMER START switch to REC.

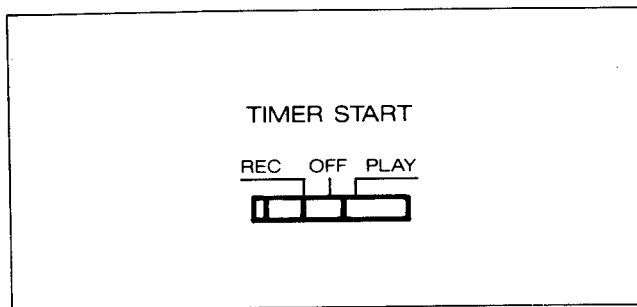

Timer controlled playback

After preparing for playback, set the timer to the timer operation mode. The connected audio components will be turned off automatically.

Set the cassette deck's TIMER START switch to PLAY.

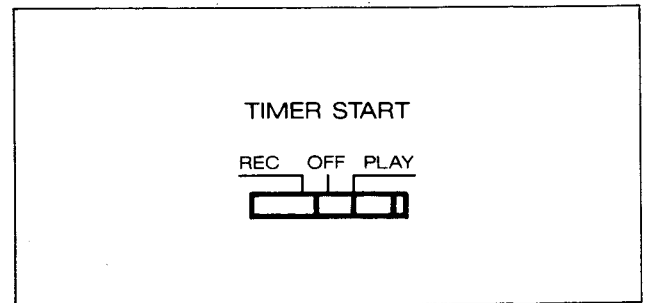

After timer controlled recording or playback is finished

Set the TIMER START switch to OFF before turning on the power of the cassette deck.

Notes for the timer operation

- Timer start recording or playback will begin 4 seconds after the power has been turned on.
- Once the timer start function has begun the operation buttons can be used freely for normal recording or playback operation.

Timer controlled recording

- Make sure your tape is of sufficient length for your recording needs.
- Do not forget to tune in the station you wish to record with the connected tuner, and to set the amplifier for broadcast station recording.
- Normally, keep the VOLUME control set to the minimum position during timer controlled recording. If you wish to listen while recording, set the VOLUME control to the normal listening level.

Important!

The illustrated power plugs and cords are intended for general reference. The power cord and plug used in your country may differ from the illustrations. (Example; U.K., Australia, U.S.A., Europe, etc.)

25-En

Example connection of the power cord

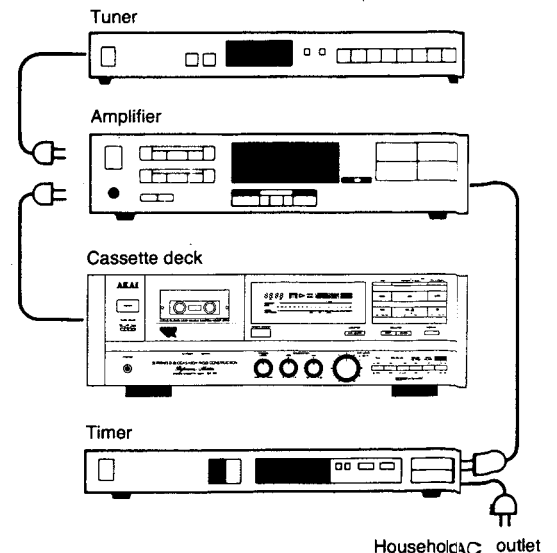

* If your amplifier is not equipped with AC outlets, connect the power cords to the timer's AC outlet.

Operation details

CD/DAT DIRECT jacks connection and recording operation

This cassette deck is equipped with exclusive digital source recording input jacks. Although this cassette deck cannot record digital signals (a D/A (Digital to Analog) converter is necessary for this), use of the digital source recording input jacks for connection of a CD player or DAT deck for recording improves the S/N (signal to noise ratio) of the cassette deck's line amplifier. For improved signal quality when recording from a CD player or DAT deck it is recommended that the CD/DAT DIRECT jacks of the cassette deck be used for connections.

Note

As this cassette deck does not include a D/A (Digital to Analog) converter it cannot be connected to the digital output jacks of a CD player or DAT deck.

Operation

Set the CD/DAT DIRECT switch to  before recording.

For normal recording

Set the CD/DAT DIRECT switch to .

Connections

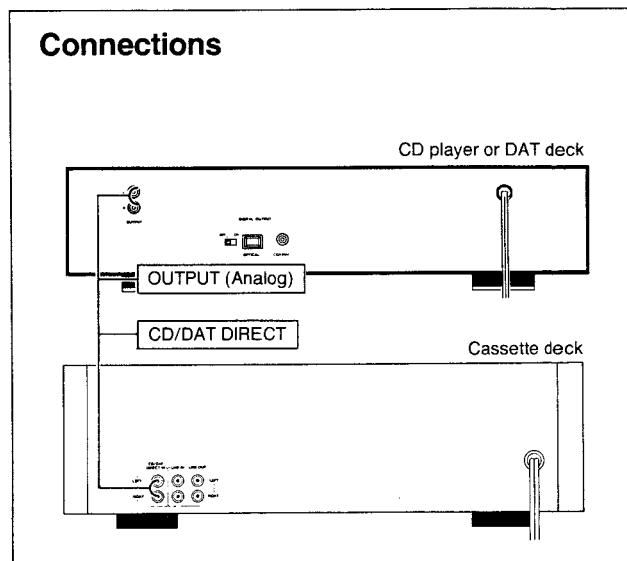

To turn the FL display on and off

Press the DISPLAY button.

In the stop mode the digital tape counter will remain on the FL display.

During playback or recording all indicators on the FL display will be turned off.

When recording or playback is begun after pressing the display button, the deck mode indicator will momentarily appear and then disappear. The digital tape counter will also disappear.

To turn the FL display back on

Press the DISPLAY button again.

The FL display generates a small amount of noise when indicators turn on or off. For the best sound results during recording and playback, it is recommended that the FL display be turned off when it is no longer necessary.

Note

- Pressing the DISPLAY button does not turn the CAL indicator, BIAS and LEVEL indicators off.
- The FL display is automatically turned on when the cassette deck's power is turned on.

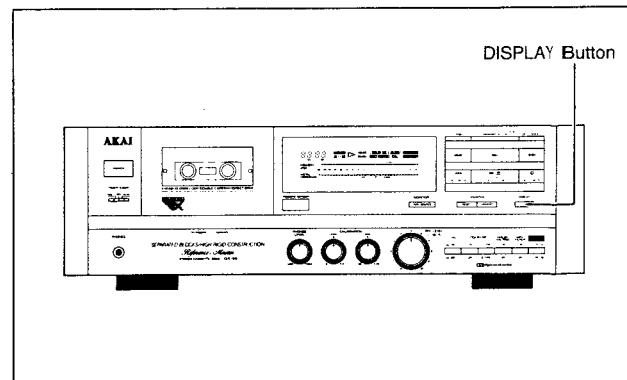

Recording with microphones

To record from microphones it will be necessary to connect a microphone mixer (not included) to the LINE IN jacks of the cassette deck. The microphones can then be connected to the microphone mixer.

The MPX (Multiplex) filter

When high frequency signals are over-emphasized during FM stereo recording, use of a noise reduction system alone is not enough.

In this case, it is necessary to use the MPX filter.

Set the MPX FILTER switch to .

What is the MPX filter?

FM stereo signals contain 19 kHz pilot signals and 38 kHz sub-carrier signals which convey the left and right channel information. These signals are necessary, but they must be removed from the output signals of the tuner. If these signals are not removed, they can affect the DOLBY NR system. The MPX filter is designed to remove these pilot tone signals from the recording.

When to use the MPX FILTER switch

Use this switch only when recording with the DOLBY NR system. Most high quality tuners have filters to suppress FM pilot tone signals. With these tuners, you can leave the MPX FILTER switch OFF. With other tuners, the MPX FILTER switch should be turned ON. The MPX FILTER switch should also be turned on when you have monitored the just recorded music and feel that the sound quality is not right.

Tape Dubbing : Making a copy from an original tape

For tape dubbing, normally connect both cassette decks to the amplifier. Refer to the amplifier's operator's manual for operation details.

It is also possible to connect directly, deck to deck. Set the recording controls (noise reduction, recording level, etc.) exactly as you would for standard recording.

The Auto stop and tape transport mechanism

Auto stop mechanism

This cassette deck is equipped with an auto stop mechanism that automatically stops the tape when it has been fully fast forwarded, fast rewind or at the end of playback or recording.

Tape transport mechanism

When the power of the cassette deck is turned on, the capstans rotate in order to stabilize tape transportation during the recording and playback modes.

The auto tape selector

How the tape positions are detected

Cassette tapes can be separated widely into three types: Normal position, chrome (CrO₂) position and metal position. Tape performances differ according to tape position and to fully utilize the performance of each tape, the cassette deck's recording/playback characteristics such as bias and equalization must be set to suit each tape position.

This cassette deck is equipped with an auto tape selector which functions automatically after you have loaded a cassette tape. Once loaded, the metal, CrO₂ or normal tape position is indicated on the FL display.

How the Auto Tape Selector operates

When a cassette tape is loaded, the cassette deck detects the tape position by sensing the tape position notches located on top of the cassette case, as illustrated.

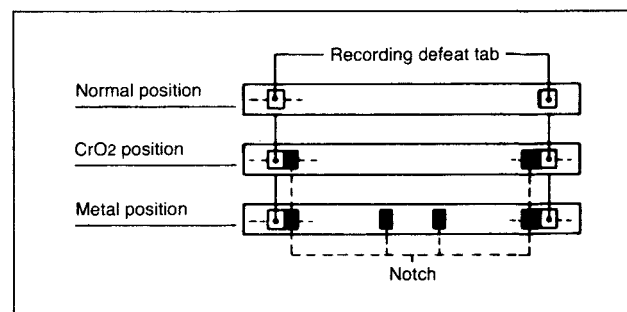

Note

- Do not use a cassette tape which does not have notches for triggering the tape position, as this will result in recordings of poor quality.
- We do not recommend the use of ferri-chrome cassette tapes for recording.

Standard reference tapes of the cassette deck

Tape position	Reference tape
Metal	TDK MA/C-60
CrO ₂ (Chrome)	TDK SA/C-60
Normal	Maxell/C-60

* C-60 (60 minutes) tapes are the standard reference tapes.

* Normally, set the BIAS and LEVEL CALIBRATION controls to "0" when using one of the standard reference tapes listed.

On the tape counter

The digital tape counter shows the amount of tape that has been played back or recorded in minutes and seconds (up to 99 minutes and 59 seconds).

Press the RESET button to reset the COUNTER to "00:00".

Counter notes

- The tape counter is intended as a guide only and is not an exact measurement of real time.
- The tape counter will be reset to "00:00" when the power is turned off or if the RESET button is pressed.

The peak level meter

The peak level meter shows the peak (maximum) level of recording and playback signals. By monitoring the peak level, it is possible to set the recording controls of this deck to realistically reproduce the dynamic characteristics of the original source. The standard recording level of this meter is indicated at 0 dB at a level of 250 nWb/m.

The peak level meter conforms to IEC standards.

Peak hold indication

The peak level of the recording signal can be held to help guide you when setting the REC LEVEL controls.

Dolby NR system

Set the proper Dolby Noise Reduction system before all recording and playback operations

When playing back a tape, set the noise reduction selector switch to the setting that was used when the tape was recorded. Set the noise reduction selector switch to OFF for tapes that were recorded without the use of the Dolby NR system.

What is the Dolby Noise Reduction (NR) System?

The DOLBY NR system is a noise reduction system designed to reduce tape noise caused when high frequency soft sounds are recorded. The DOLBY NR system does this by lowering the noise floor in order to increase the dynamic room in the high frequency range above 5 kHz.

During recording, the DOLBY NR encoder circuit boosts soft high frequency sounds, and then during playback the DOLBY NR decoder circuit lowers what was boosted by exactly the same amount to restore the high frequencies to their original levels. At the same time, tape noise is lowered by the same amount.

The result is reduction of up to 10 dB in unwanted tape noise in the high frequencies.

What is the difference between Dolby B-type and C-type NR systems?

B-type: This is the conventional Dolby NR system. It boosts or lowers the low-level signals at high frequencies only (more than 5 kHz) and reduces tape noise by 10 dB.

C-type: Compared to Dolby B NR, it operates at lower frequencies (from 500 Hz) for uniform noise reduction across more of the audible spectrum. Tape noise is reduced by as much as 20 dB.

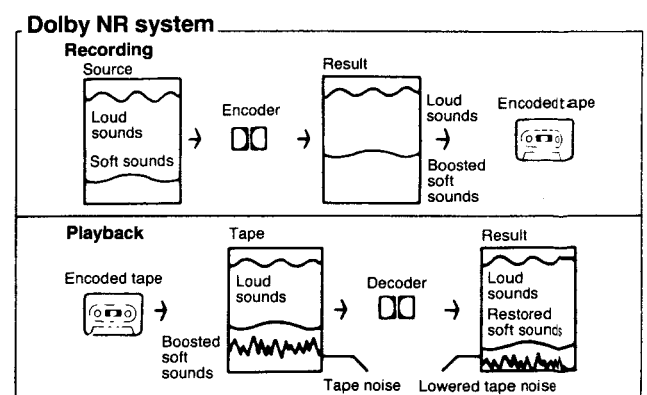

Double process noise reduction system

In a conventional noise reduction system, one circuit acts both as an encoder and decoder, and is switched to one or the other accordingly.

The double process noise reduction system has an encoder circuit in the recording amplifier section, and a decoder in the playback amplifier section. The double process noise reduction system is used in cassette decks with 3 independent heads (recording, playback, and erase). Therefore, when recording with a noise reduction system, you can immediately confirm the effect of the noise reduction by monitoring the just recorded music.

On the DOLBY HX PRO Headroom extension system

The Dolby HX PRO system (HX stands for Headroom eXtension) is a system designed to improve the saturation level of cassette tapes by controlling the bias current. This improved saturation level means clearer sound when recording classical music, or other music that contains many instruments. Although it is a Dolby system the HX PRO headroom extension system should not be confused with Dolby NR as it is not a noise reduction system.

The Dolby HX PRO headroom extension system is basically a circuit used in cassette decks that makes use of the fact that the amount of high frequency energy that the tape can hold varies according to the amount of bias current present. Less bias current will result in more headroom for the high frequencies, but at an increase in low-frequency distortion. More bias helps to lower distortion, but results in loss of high frequency "headroom". During recording, the Dolby HX PRO headroom extension circuit monitors the recording signal. When high frequency peaks that are too high are detected, the bias is reduced momentarily so that those peaks can be accommodated. This is especially helpful for signals which have high levels at high frequencies. When these peaks are no longer present, the bias is restored to the normal level.

Even when using a normal position tape during recording, the Dolby HX PRO headroom extension system works to improve its saturation level to almost that of a metal position tape. Because the system is built into the recording circuits, it is working whenever recording is taking place. Cassette tapes recorded with the Dolby HX PRO headroom extension system can be played back without any problems on any cassette deck.

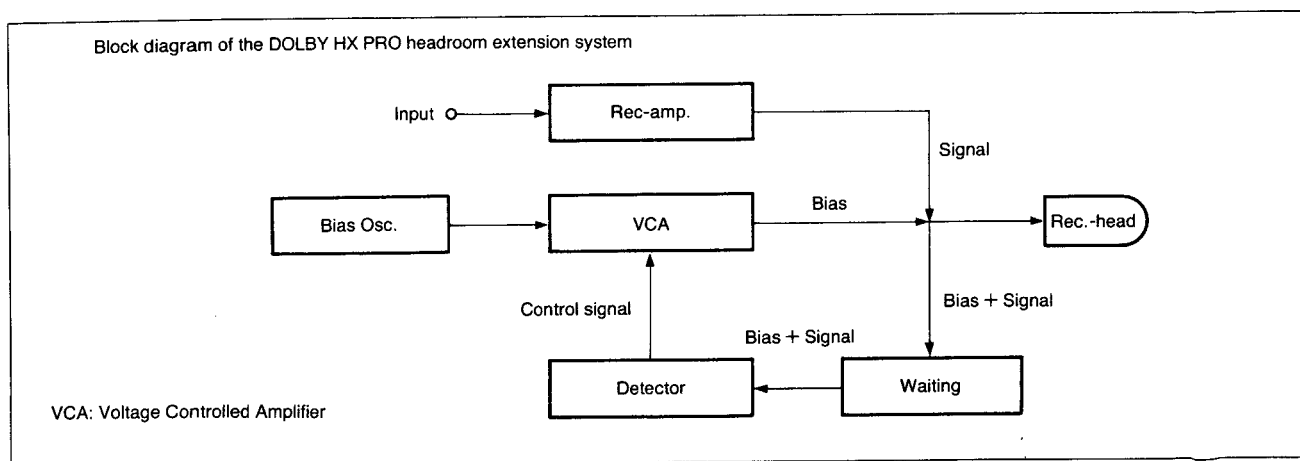

- * "DOLBY" and the double-D symbol  and "HX PRO" are trademarks of DOLBY Laboratories Licensing Corporation. (Dolby noise reduction and HX Pro headroom extension manufactured under license from Dolby Laboratories Licensing Corporation. HX Pro originated by Bang & Olufsen.)

Cassette deck maintenance

24

Keep your stereo cassette deck clean

After prolonged use, parts of your cassette deck which come in contact with the tape (Heads, capstan, pinch roller and tape guide, etc.) become dirty due to oxide from the tape and other contaminations.

This can lead to such problems as no sound, distorted sound due to unstable tape transport, etc.

To ensure good performance, you should periodically clean your stereo cassette deck.

How to remove the cassette lid

- 1 Press the  button to open the cassette holder.
- 2 Grasp both sides of the cassette lid and gently pull up to remove.
- 3 Align the cassette lid with the cassette holder and push it down in the opposite direction of the arrows to replace the cassette lid.

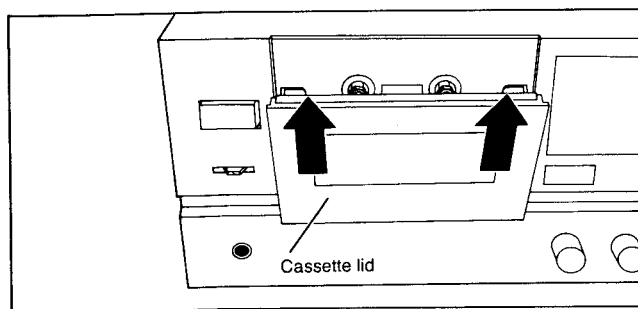

Mechanism layout

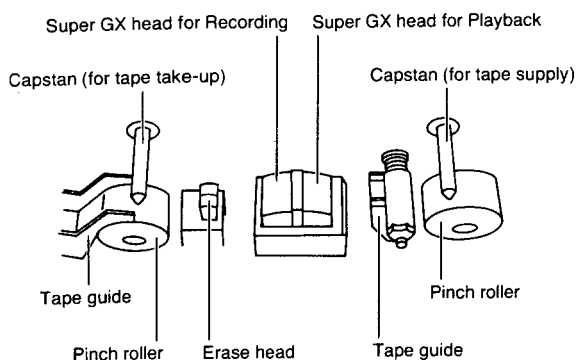

Cleaning the deck

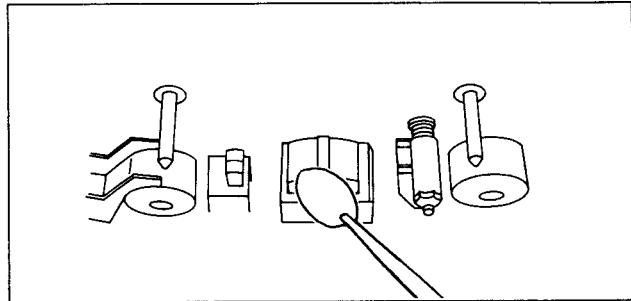

Use the optional accessory Akai Cleaning kit CK-310 or cleaning tape.

Dip the cotton swab into the appropriate cleaning fluid (most cleaning kits contain two types of cleaning fluid; one for metal parts and one for rubber and plastic parts) and wipe the surface of the heads, tape guides, capstans and pinch rollers.

After cleaning, wipe with a dry cotton swab.

Use your stereo cassette deck only after the parts have completely dried.

* Use a liquid cleaner exclusively meant for tape decks. For best results, always clean your stereo cassette deck before an important recording.

Keeping the head demagnetized

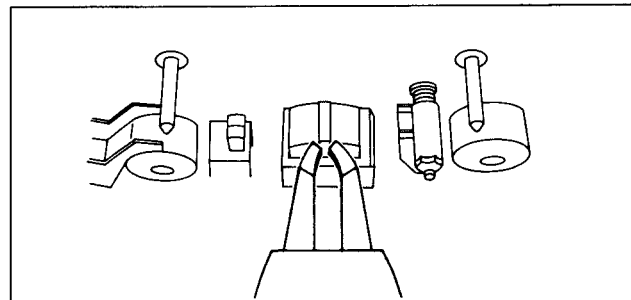

After much use, slight magnetism can build up on the recording and playback head causing loss in high frequency sound and increases in noise. To eliminate this problem you should periodically demagnetize the head with the optional accessory Head Demagnetizer AH-15. Demagnetize the metal parts of the capstan as well.













Before demagnetizing

Turn off your stereo cassette deck.

Keep the cabinet clean too

- Clean the cabinet with a soft, dry cloth.
- If the cabinet is excessively dirty, clean it with a mild detergent.
- Never use paint thinner, etc. to clean the cabinet, as this may damage the finish.

Troubleshooting

Problem	Check point
No power.	<ul style="list-style-type: none"> ● Power cord is not connected properly. Check the power cord connection.
No sound.	<ul style="list-style-type: none"> ● Improper connections. Check that the connection cords are properly connected. ● The connected amplifier's input selector is not set properly. Check the input selector. ● The CAL switch is set to . Set the switch to . ● The tape monitor switch is not set properly. Set the switch to SOURCE or TAPE by pressing the MONITOR button.
The stereo cassette deck goes into recording or playback when the power is turned on.	<ul style="list-style-type: none"> ● The TIMER START switch is set to REC or PLAY. Set the switch to OFF.
Recording will not take place.	<ul style="list-style-type: none"> ● The cassette tape's recording defeat tabs are removed. Cover them with adhesive tape. ● The  button is not pressed. Press the . ● The  button is not pressed. Press the . ● The REC LEVEL controls are set too low. Increase the recording levels with the controls. ● The CAL switch is set to  after calibration. Set the switch to . ● The CD/DAT DIRECT switch is not set properly. Leave the switch to  for normal recording. Set the switch to  when recording from the CD/DAT DIRECT jacks.
Distorted recording or playback.	<ul style="list-style-type: none"> ● Recording levels are set too high. Decrease the recording levels with the control. ● The noise reduction selector is not set properly. Reset it. ● The recording and playback heads are dirty. Clean the heads.
The cassette deck goes into playback automatically during tape winding.	<ul style="list-style-type: none"> ● The IPSS is engaged. Press the IPSS button to cancel the IPSS before winding the tape.
IPSS will not function properly.	<ul style="list-style-type: none"> ● The blank spaces between selections are less than 4 seconds long. Use the  button during recording to create the proper length of blank space.
High frequency sounds are stressed during playback. Low and middle frequency sounds are stressed during playback.	<ul style="list-style-type: none"> ● The Noise reduction selector is not set properly. Set the switches according to how the tape was recorded. ● The MPX FILTER switch is set to . Set the switch to  before FM broadcast recording. ● The BIAS and LEVEL CALIBRATION controls are not adjusted properly. Adjust the BIAS and LEVEL CALIBRATION controls properly by depressing the CAL button before recording.
Wow and flutter in the sound.	<ul style="list-style-type: none"> ● Dirty heads, capstans, tape guides or pinch rollers. Clean all tape transport mechanism parts.

Problem	Check point
Tape stops automatically during tape winding.	<ul style="list-style-type: none"> ● The memory stop system is engaged. Press the MEMORY button to turn it off. ● The end of the tape is reached. Turn over the tape or press the opposite operation button ◀◀ or ▶▶ button for example.
REC CANCEL button does not engage when pressed.	<ul style="list-style-type: none"> ● The cassette deck is not in the recording mode. Use the REC CANCEL button during recording. ● The section to be erased has not been memorized with the MEMORY A→B button. Use the MEMORY A→B button to memorize the section to be erased.
The cassette deck will not operate.	<ul style="list-style-type: none"> ● The half speed playback function is engaged. Press the ■/▲ button to cancel the function.
The FL display is turned off.	<ul style="list-style-type: none"> ● The DISPLAY button is pressed. Press the button to turn the FL display on.
Playback will not start automatically from the "00:00" position of the tape counter.	<ul style="list-style-type: none"> ● The memory system is not engaged. Press the MEMORY button to turn on the memory system. ● The ▶ button and ◀◀ buttons were not pressed simultaneously. Press the ◀◀ and ▶ buttons simultaneously.
The memorized interval is erased.	<ul style="list-style-type: none"> ● The REC CANCEL button was pressed. Make sure to press the ◀◀ button or ▶ button to start 2-point repeat playback.

Should a problem persist write down the model and serial number and all pertinent data regarding warranty coverage as well as a clear description of the existing trouble. Then contact your nearest authorized Akai service station.

Specifications

Track system.....	4 track 2 channel stereo
Heads.....	LC-OFC Super GX head for recording ×1 LC-OFC Super GX head for playback ×1 Erase head ×1
Motors.....	FG Servo D.D. motor for capstan drive ×1 DC motor for reel drive ×1 DC motor for cam & tape eject/loading drive ×1
Wow & flutter.....	0.025% WRMS (JIS), 0.04% (DIN)
S/N (Metal).....	59 dB (Measured via tape with peak recording level) Dolby B type NR switch ON: Improves up to 5 dB at 1 kHz, 10 dB above 5 kHz Dolby C type NR switch ON: Improves up to 15 dB at 500 Hz, 20 dB at 1 kHz to 10 kHz
T.H.D. (Metal).....	Less than 0.6%
Frequency response	
Normal.....	20 Hz to 19,000 Hz ±3 dB
CrO ₂	20 Hz to 20,000 Hz ±3 dB
Metal.....	20 Hz to 21,000 Hz ±3 dB
Input sensitivity/Impedance	
Line.....	70 mV/47 kohms
CD/DAT direct in.....	240 mV/47 kohms
Output sensitivity/Impedance	
Line.....	388 mV/150 ohms
Headphones.....	1.3 mW (8 ohms)
Power requirements.....	220 V, 50 Hz for Europe except UK 240 V, 50 Hz for UK and Australia 110 V/120 V/220 V/240 V, 50/60 Hz convertible for other countries
Dimensions.....	460 (W) × 154 (H) × 350 (D) mm (18.1 × 6.1 × 13.8 inches)
Weight.....	10.2 kg (22.4 lbs)

Standard accessories

Connection cords.....	2
Remote control unit (RC-G95).....	1
Batteries for remote control unit.....	2

* For improvement purposes, specifications and design are subject to change without notice.

Features

- 3-head system featuring Super GX heads incorporating LC-OFC (Linear Crystal-Oxygen Free Copper) windings.
- Micro computer controlled direct lead-in and power eject system with original Quick and Quiet mechanism.
- Closed loop dual capstan drive system by direct drive.
- Stable tape transport mechanism with wide face tape guides.
- Auto monitor system.
- Auto tape slack take up system.
- Spot erase system.
- Convenient recording cancel and auto mute system.
- 2 point repeat playback function.
- Large concentrated FL display with display on/off function for reducing unwanted noise.
- Peak level meter with peak hold system.
- Dolby HX PRO headroom extension system.
- Double process Dolby B and C type noise reduction system.
- Recording calibration system with bias and level controls.
- Separated block construction.
- High rigid design.
- Large pedestals.
- Cassette stabilizer attached cassette holder.
- Remote controllable with the provided remote control unit.
- Timer start function.
- Easy to operate large diameter recording level control.
- Digital time tape counter.
- Counter memory stop system.
- Auto play system.
- 16 selection IPSS function.
- Recording level guide system.
- Independent multiplex filter switch.
- CD/DAT switch and jacks.
- Headphones jack and level control.
- Auto tape selector system.

Sistema de pistas	4 pistas, 2 canales estereofónicos
Cabezales	1 cabezal LC-OFC super GX para grabación 1 cabezal LC-OFC super GX para reproducción 1 cabezal de borrado
Motores	1 motor servocontrolado por FG, para accionamiento directo del cabrestante 1 motor a CC para accionamiento del carrete 1 motor a CC para accionamiento de leva y carga/expulsión de cinta
Lloro y fluctuación	0,025% (valor eficaz JIS), 0,04% (DIN)
Relación S/R (metal)	59 dB (Medida mediante grabación con niveles instantáneos máximos) Interruptor Dolby NR tipo B activado: mejora hasta 5 dB a 1 kHz, 10 dB por encima de 5 kHz. Interruptor Dolby NR tipo C activado: mejora hasta 15 dB a 500 Hz, 20 dB de 1 kHz a 10 kHz.
Distorsión armónica total (metal)	Inferior a 0,6%
Respuesta de frecuencia	
Normal	20 Hz a 19000 Hz \pm 3 dB
CrO ₂	20 Hz a 21000 Hz \pm 3 dB
Metal	20 Hz a 21000 Hz \pm 3 dB
Sensibilidad/impedancia de entrada	
LINE	70 mV/47 kohmios
CD/DAT DIRECT IN	240 mV/47 kohmios
Sensibilidad/impedancia de salida	
LINE	388 mV/150 kohmios
Auriculares	1,3 mW (8 ohmios)
Suministro de energía	220 V, 50 Hz para Europa exceptuando al Reino Unido y Australia 110 V/120 V/220 V/240 V, 50/60 Hz, seleccionable para otros países
Dimensiones	460 (ancho) \times 154 (alto) \times 350 (prof.) mm.
Peso	10,2 kg

Accesorios incluidos

Cables de conexión	2
Unidad de control remoto (RC-G95)	1
Pilas para la unidad de control remoto	2

* Con el propósito de introducir mejoras, las especificaciones y el diseño del producto están sujetos a cambios sin previo aviso.

Características

- Sistema de 3 cabezales super GX que incorpora devanados LC-OFC (cristal lineal — cobre libre de oxígeno).
- Sistema de entrada directa y expulsión del cassette controlado por microcomputador, con el mecanismo "Quick and Quiet" original.
- Sistema de bucle cerrado para accionamiento directo de dos cabrestantes.
- Mecanismo estable de transporte de la cinta, con anchas guías de cinta.
- Sistema de monitoreo automático.
- Sistema de eliminación automática de la flojedad de la cinta.
- Sistema de borrado selectivo.
- Prácticas funciones de cancelación de grabación y silenciamiento automático.
- Función de repetición selectiva de la reproducción (entre 2 puntos).
- Amplio visualizador FL concentrado, con función de activación/desactivación para disminuir ruidos no deseados.
- Medidor de nivel instantáneo máximo con función de retención de nivel máximo.
- Sistema Dolby HX PRO
- Sistema de reducción de ruido Dolby tipo B y C de proceso doble.
- Sistema de calibración de grabación, con controles de polarización y nivel.
- Construcción por bloques.
- Diseño altamente sólido.
- Bases grandes y estables.
- Estabilizador de cassette incorporado al portacassette.
- Operación a control remoto mediante la unidad de control remoto proporcionada.
- Función de activación por temporizador.
- Control de nivel de grabación de gran tamaño y fácil uso.
- Contador digital de cinta.
- Sistema de detención por memoria de contador.
- Sistema de reproducción automática.
- Función IPSS (sistema de localización instantánea de programa) para 16 selecciones.
- Sistema de guía de nivel de grabación.
- Interruptor de filtro múltiplex independiente.
- Interruptor y conectores CD/DAT DIRECT.
- Conector y control de nivel de auriculares.
- Selector automático de cinta.

AKAI

AKAI ELECTRIC CO., LTD.

12-14, Higashi-Kojiya, 2-chome,
Ohta-ku, Tokyo, Japan



880718-②-1

C E U3 U5 U8

AEP
Printed in Japan