

# AKAI SERVICE MANUAL

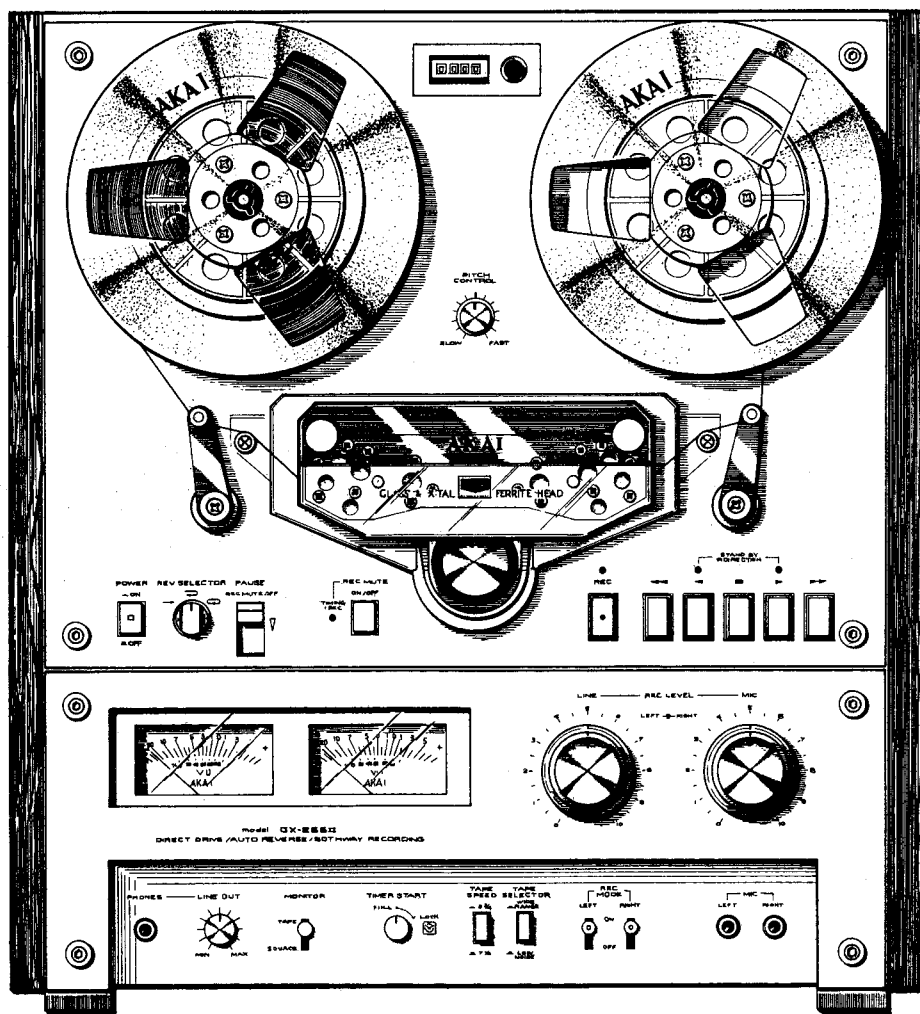

STEREO TAPE DECK

MODEL **GX-266II**

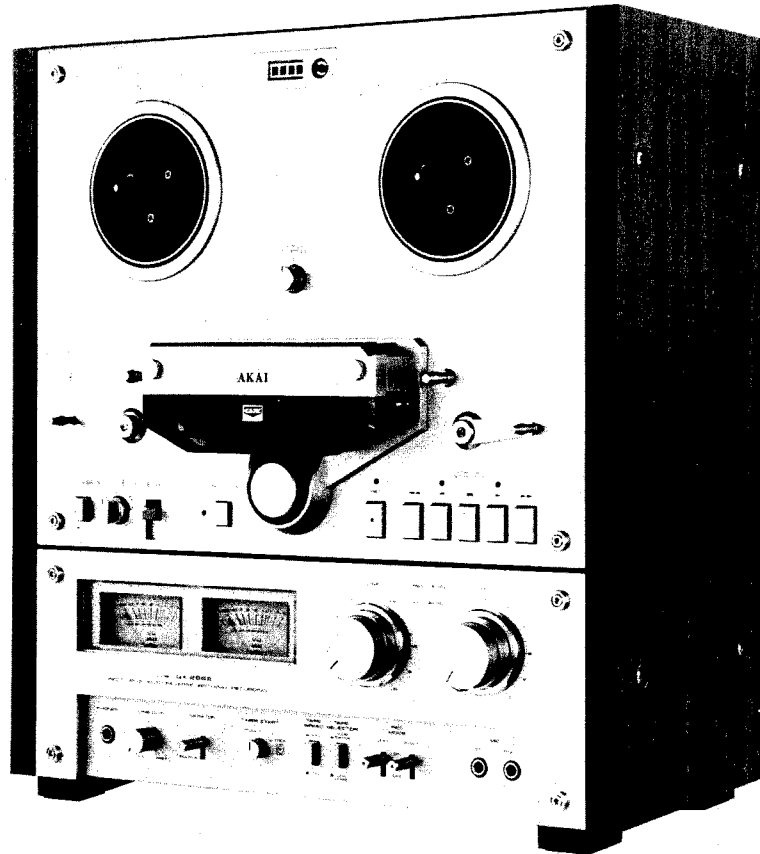

**STEREO TAPE DECK**

**MODEL GX-266II**

ALSO APPLICABLE TO BLACK PANEL MODEL

SECTION 1	SERVICE MANUAL .....	3
SECTION 2	PARTS LIST .....	39
SECTION 3	SCHEMATIC DIAGRAM .....	63

---

SECTION 1

**SERVICE MANUAL**

TABLE OF CONTENTS

I.	TECHNICAL DATA .....	4
II.	DISMANTLING OF UNIT .....	5
III.	CONTROLS .....	8
IV.	PRINCIPAL PARTS LOCATION .....	10
V.	VOLTAGE AND CYCLE CONVERSION .....	12
	1. VOLTAGE CONVERSION .....	12
	2. CYCLE CONVERSION .....	13
VI.	CIRCUIT OPERATING PRINCIPLES .....	14
	1. CIRCUIT CONSTRUCTION OF IC1 M54410P .....	14
	2. THE SAMPLE AND HOLD SYSTEM SERVO MOTOR (SCM-200) OPERATION .....	16
VII.	MECHANISM ADJUSTMENT .....	19
	1. TAPE GUIDE HEIGHT ADJUSTMENT .....	19
	2. TENSION MICROSWITCH POSITION ADJUSTMENT .....	19
	3. REEL TABLE HEIGHT ADJUSTMENT .....	19
	4. BRAKE PLUNGER INSTALLATION POSITION ADJUSTMENT .....	20
	5. BRAKE MICROSWITCH INSTALLATION POSITION ADJUSTMENT ..	20
	6. BRAKE BAND POSITION AND BRAKE TENSION ADJUSTMENT ...	21
	7. PINCH ROLLER PLUNGER INSTALLATION POSITION AND PINCH ROLLER PRESSURE ADJUSTMENT ...	21
	8. PAUSE MECHANISM ADJUSTMENT .....	22
	9. CAPSTAN SHAFT LOOSE PLAY ADJUSTMENT .....	22
	10. TAPE SPEED ADJUSTMENT .....	23
VIII.	HEAD ADJUSTMENT .....	24
IX.	AMPLIFIER ADJUSTMENT .....	26
X.	DC RESISTANCE OF VARIOUS COILS .....	28
XI.	CLASSIFICATION OF VARIOUS P.C BOARDS .....	28
	1. P.C BOARD TITLES AND IDENTIFICATION NUMBERS .....	28
	2. COMPOSITION OF VARIOUS P.C BOARDS .....	29

For basic adjustments, measuring methods, and operating principles, refer to GENERAL TECHNICAL MANUAL.

# I. TECHNICAL DATA

TRACK SYSTEM	4 track 2 channel stereo/monaural system
REEL CAPACITY	Up to 7" reel
TAPE SPEED	19 cm/s $\pm$ 0.8% (7-1/2 ips) 9.5 cm/s $\pm$ 1.0% (3-3/4 ips) (Pitch control : $\pm$ 6%)
WOW & FLUTTER	Less than 0.03% WRMS, 0.09% DIN 45500 at 19 cm/s Less than 0.04% WRMS, 0.11% DIN 45500 at 9.5 cm/s
FREQUENCY RESPONSE	30 to 26,000 Hz $\pm$ 3 dB at 19 cm/s (WR Tape) 30 to 19,000 Hz $\pm$ 3 dB at 9.5 cm/s (WR Tape)
DISTORTION	Less than 0.5% (at 1,000 Hz 0 VU)
SIGNAL TO NOISE RATIO	Better than 62 dB DIN 45500 at 19 cm/s
ERASE RATIO	Better than 70 dB (at 1,000 Hz)
CROSS TALK	Better than 40 dB (at 1,000 Hz)
CHANNEL SEPARATION	Better than 55 dB (at 1,000 Hz)
BIAS FREQUENCY	100 kHz
HEADS	(6): Two GX recording heads, Two GX playback heads Two erase heads
MOTORS	(3): One AC servo motor for capstan drive Two AC eddy current motors for reel drive
F.F & RWD. TIME	90 sec. using 360 m (1,200 ft.) Tape
OUTPUT JACKS	Line (2): 0.775 V (0 VU) Required load impedance: more than 20 kohms Phone (1): 100 mV/8 ohms
INPUT JACKS	Microphone (2): 0.25 mV Required microphone impedance: 600 ohms Line (2): 70 mV Input impedance 100 kohms
DIN JACK	Input: 2.0 mV Input impedance 10 kohms Output: 0.3 V
DIMENSIONS	440 (W) $\times$ 470 (H) $\times$ 250 (D) mm (17.4 $\times$ 18.5 $\times$ 9.8")
WEIGHT	18.7 kg (41.3 lbs)
POWER REQUIREMENT	100V 50/60 Hz switchable for JAPAN 120V 60 Hz for US & Canada 220/240V switchable, 50 Hz for European countries & Australia 110/120/220/240V, 50/60 Hz switchable for other countries
POWER CONSUMPTION	65 W for JPN, CSA Model 90 W for U/T Model

\* Specifications determined with Akai LN-150-7 or SCOTCH #211 tape unless otherwise noted.

\* For improvement purposes, specifications and design are subject to change without notice.

## II. DISMANTLING OF UNIT

In case of trouble, etc. necessitating dismantling, please dismantle in the order shown in the photographs. Reassemble in reverse order.

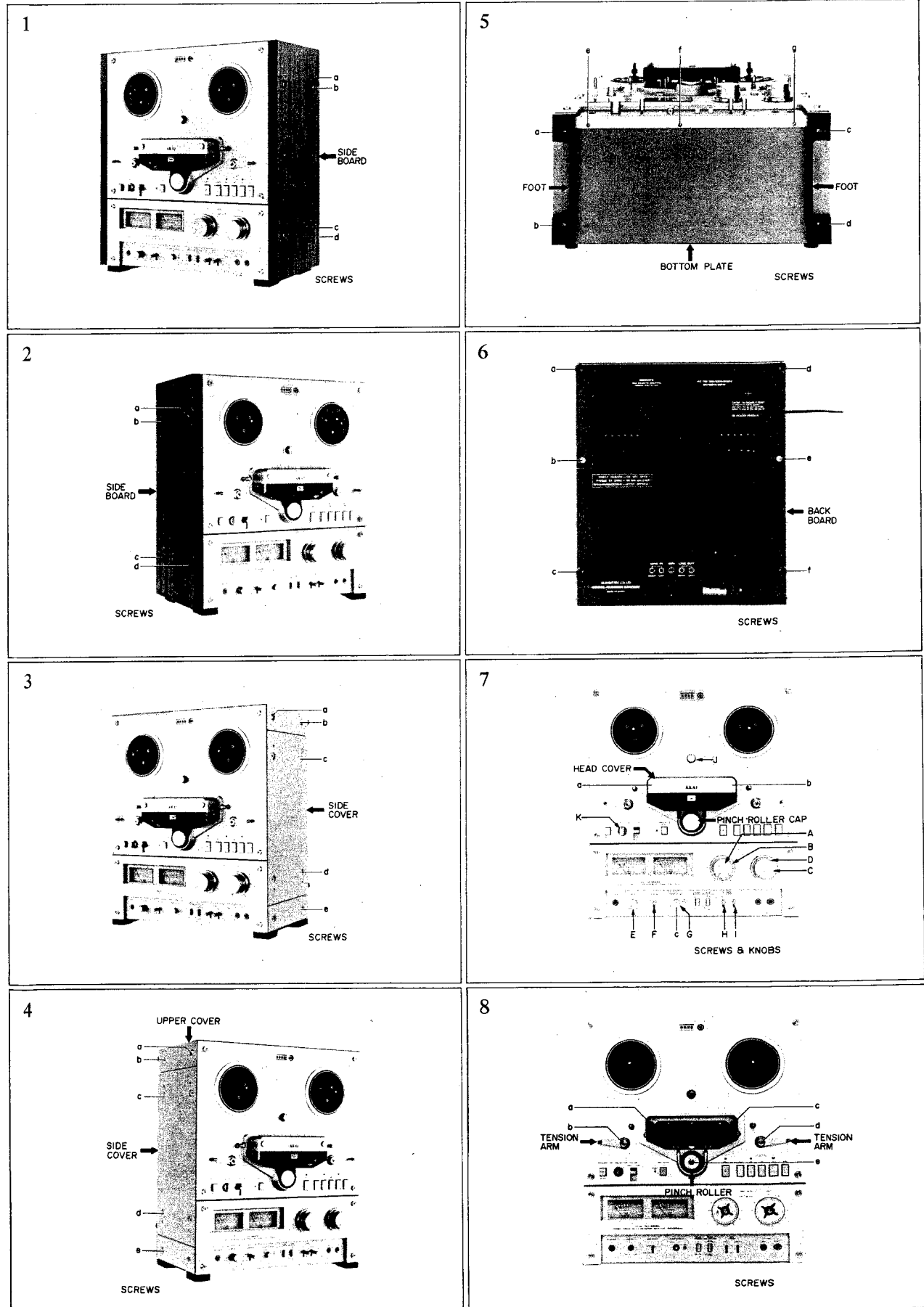

9

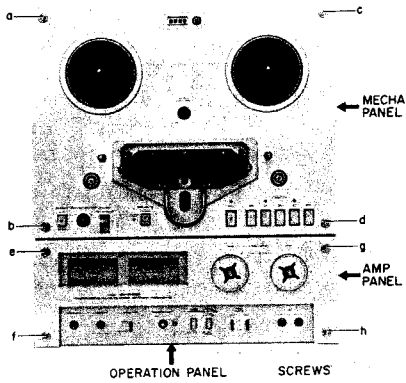

11

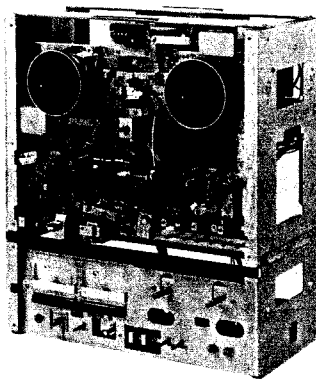

10

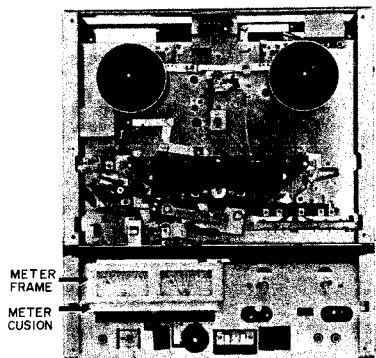

### III. CONTROLS

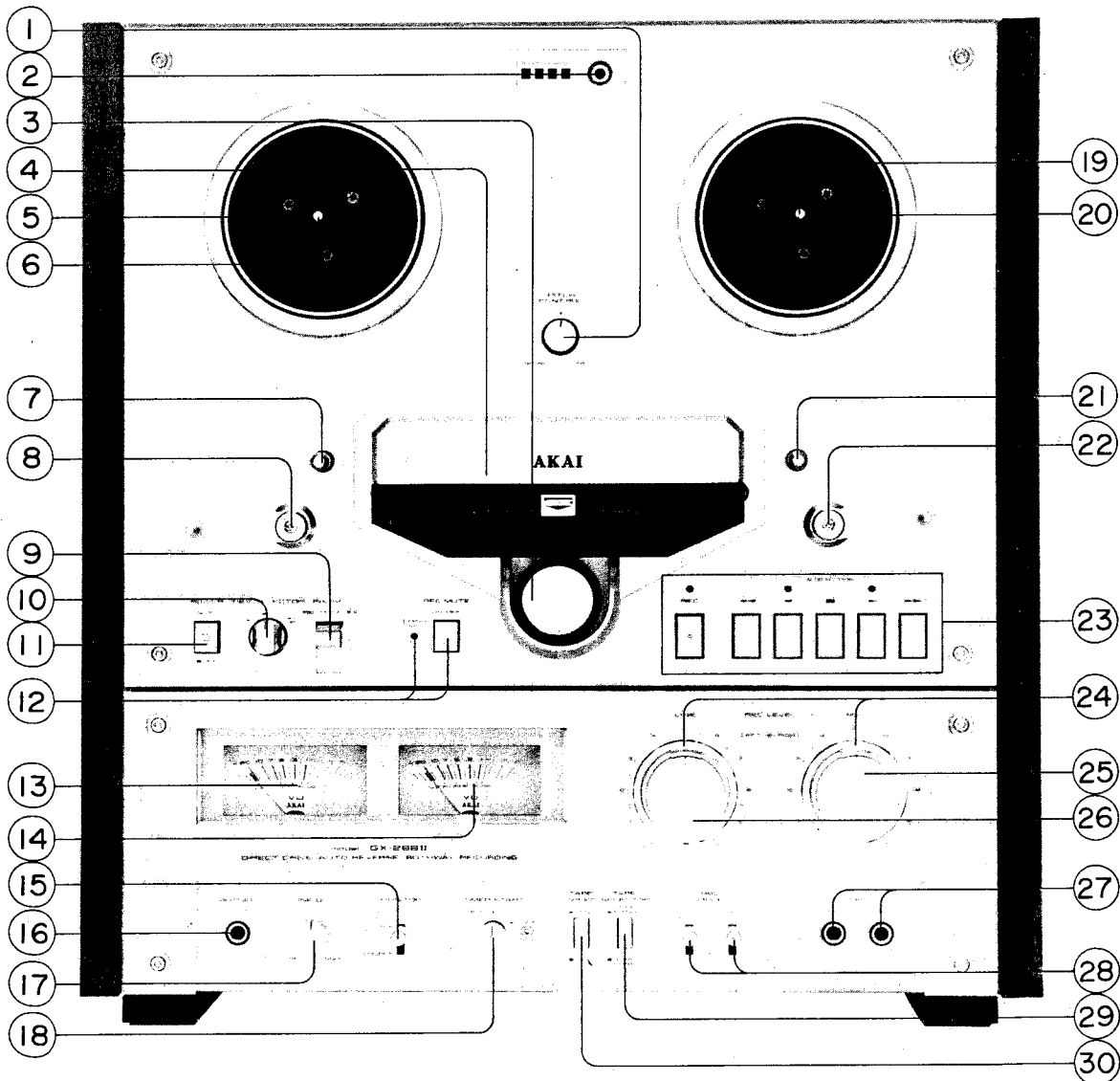

- |  |   |
|--|---|
| 1. PITCH CONTROL                                   | 10. REVERSE SELECTOR                                |
| 2. INDEX COUNTER AND RESET BUTTON                  | 11. POWER SWITCH                                    |
| 3. PINCH ROLLER                                    | 12. RECORDING MUTE SWITCH<br>(REC MUTE)/TIMING LAMP |
| 4. HEAD COVER                                      | 13. VU METER (LEFT)                                 |
| 5. SUPPLY REEL TABLE                               | 14. VU METER (RIGHT)                                |
| 6. BUILT-IN REEL RETAINER (LEFT)                   | 15. MONITOR SWITCH                                  |
| 7. TAPE GUIDE (SENSING POLE:<br>FORWARD → REVERSE) | 16. HEADPHONE JACK                                  |
| 8. LEFT TENSION ARM                                | 17. OUTPUT LEVEL CONTROL                            |
| 9. PAUSE/REC MUTE OFF                              | 18. TIMER START SWITCH (TIMER START)                |

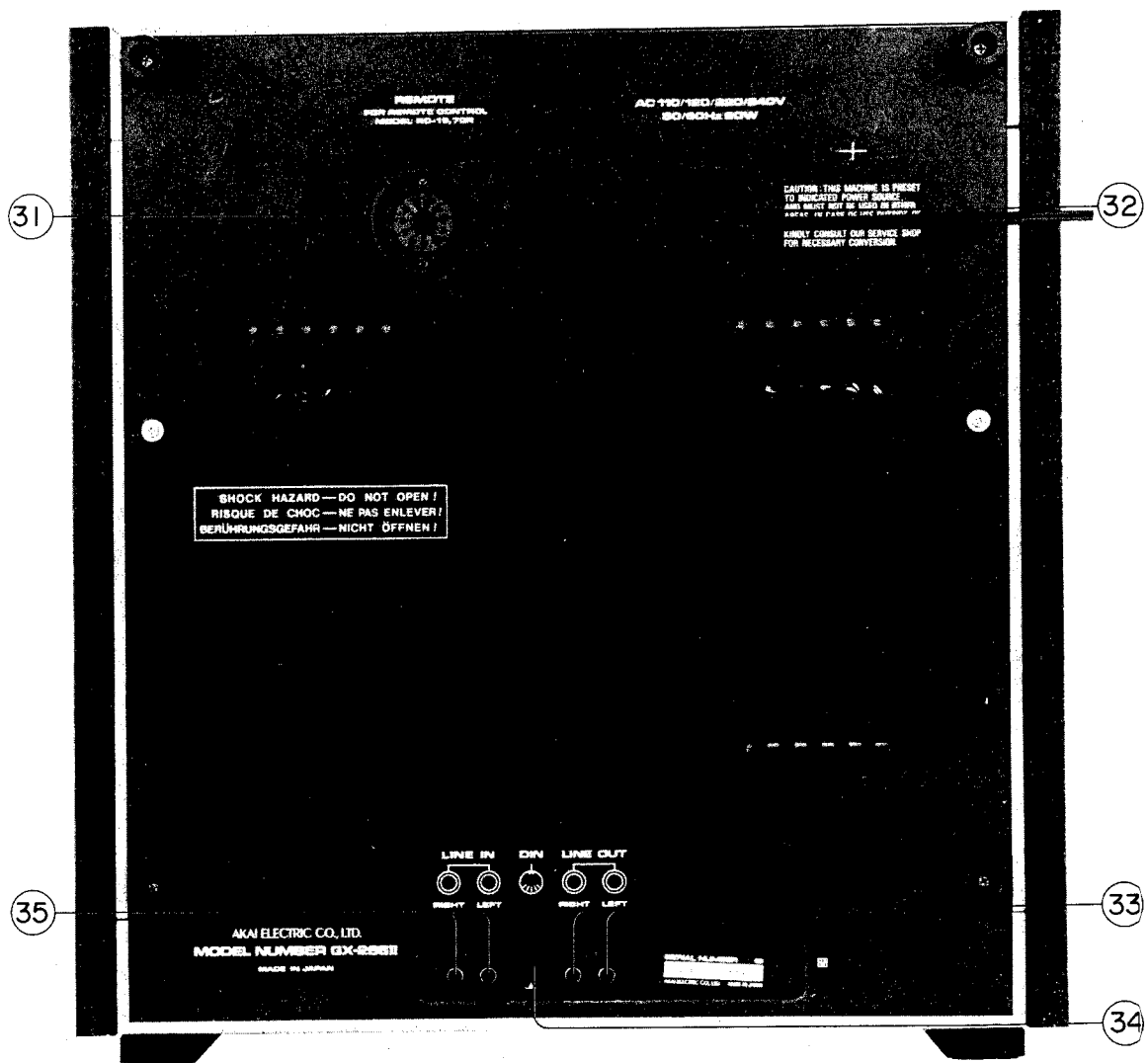

Fig. 1 Controls

- |   |   |
|---|---|
| 19. BUILT-IN REEL RETAINER (RIGHT)                  | 28. RECORDING MODE LEVERS<br>(LEFT AND RIGHT CHANNEL SELECTORS) |
| 20. TAKE-UP REEL TABLE                              | 29. TAPE SELECTOR SWITCH  |
| 21. TAKE GUIDE (SENSING POLE:<br>REVERSE → FORWARD) | 30. TAPE SPEED SELECTOR   |
| 22. RIGHT TENSION ARM                               | 31. REMOTE CONTROL JACK   |
| 23. MODE BUTTONS                                    | 32. POWER CORD (AC INLET FOR SOME COUNTRIES)                    |
| 24. MEMORY MARKERS                                  | 33. LINE OUTPUT JACKS (LEFT/RIGHT)                              |
| 25. MICROPHONE INPUT CONTROLS (REC LEVEL-MIC)       | 34. DIN JACK (SOME MODELS DO NOT HAVE THIS FACILITY)            |
| 26. LINE INPUT CONTROLS (REC LEVEL-LINE)            | 35. LINE INPUT JACKS (LEFT/RIGHT)                               |
| 27. MICROPHONE JACKS (LEFT/RIGHT)                   |   |



# IV. PRINCIPAL PARTS LOCATION

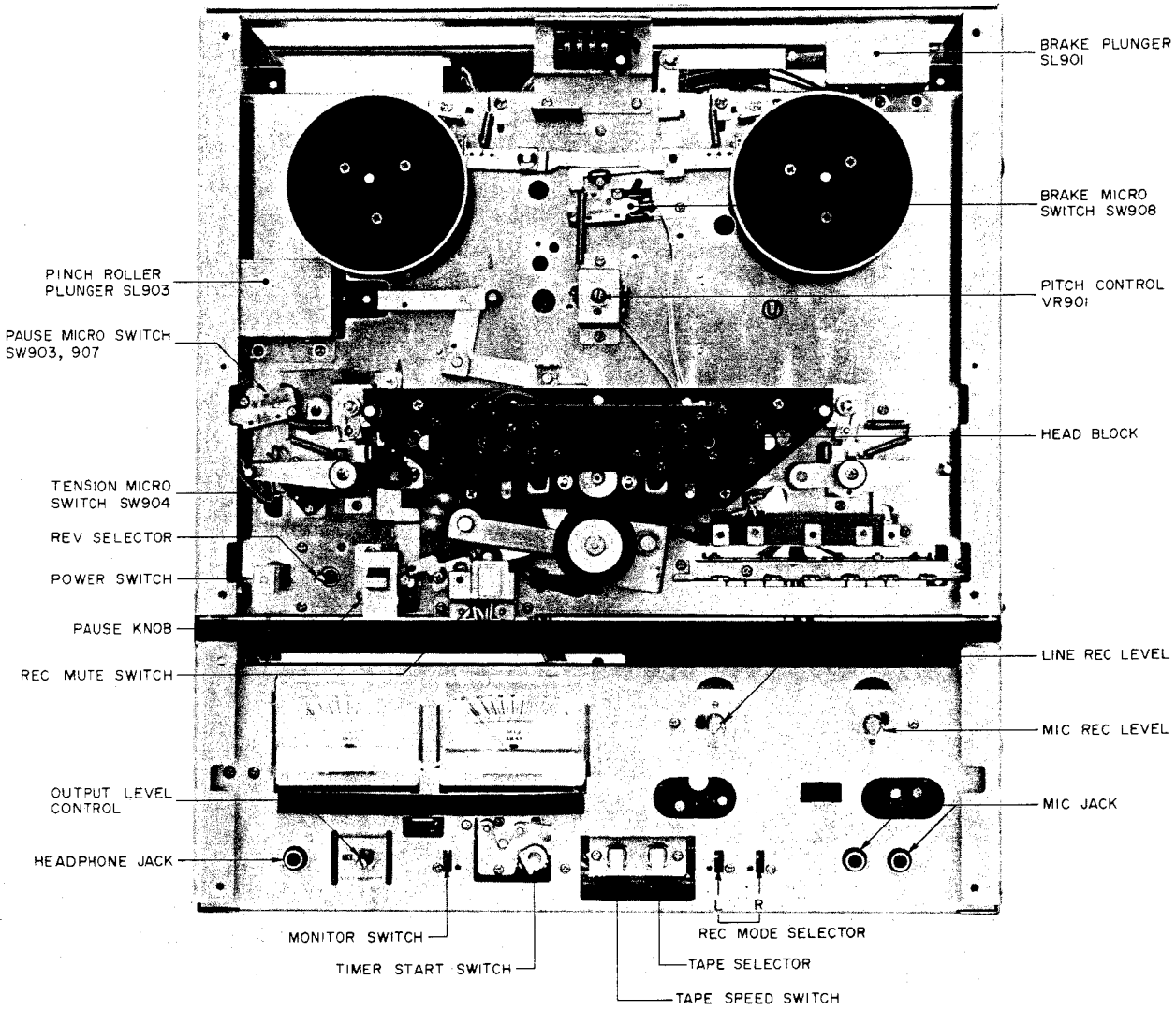

Fig. 2 Front View

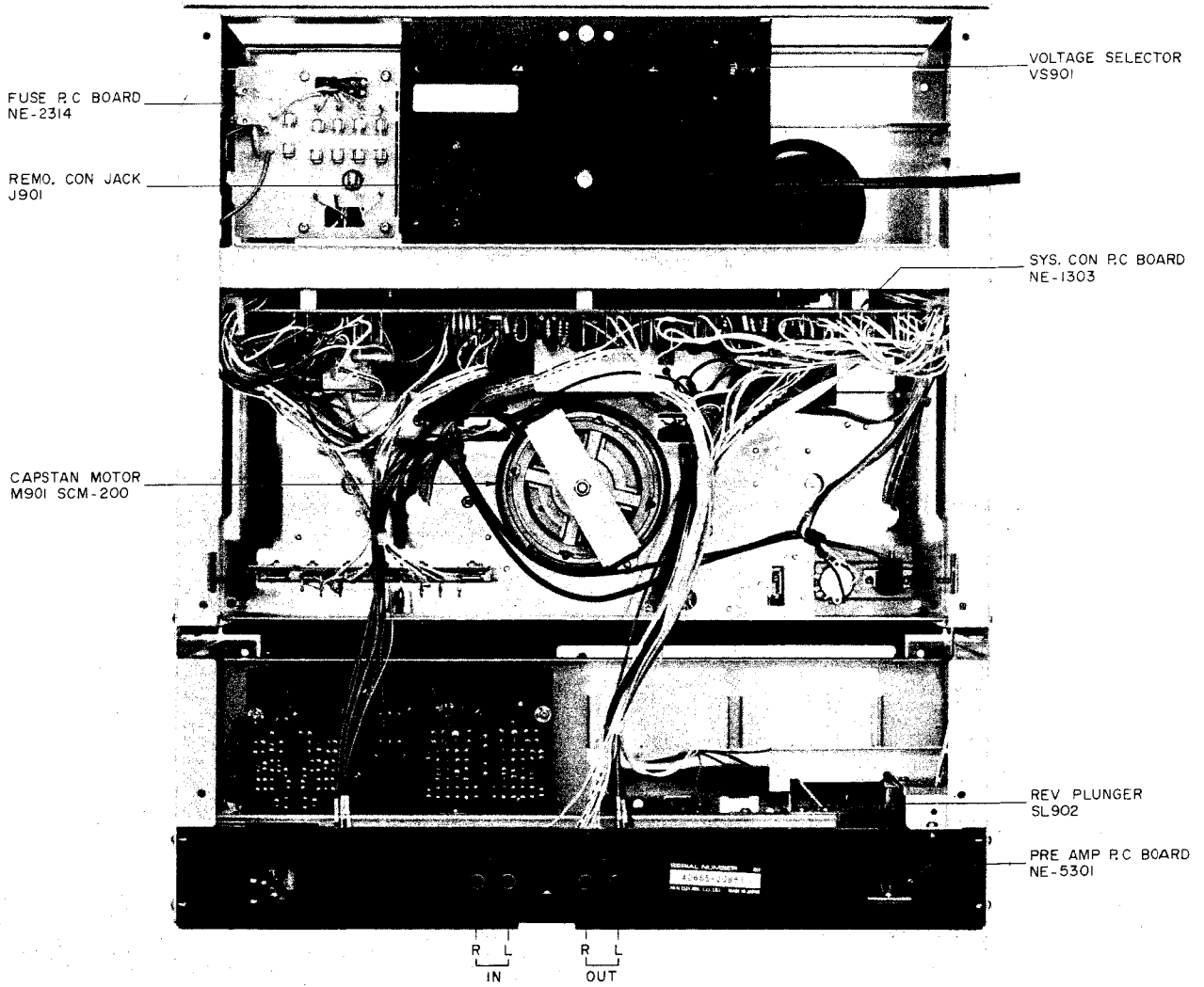
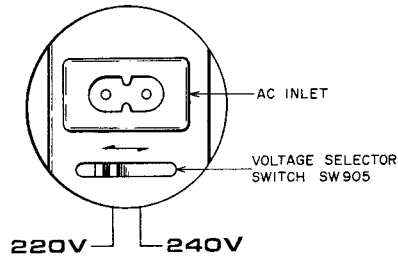

Fig. 3 Rear View

# V. VOLTAGE AND CYCLE CONVERSION

AC 220V/240V 50Hz~



(a) CEE, UK Model

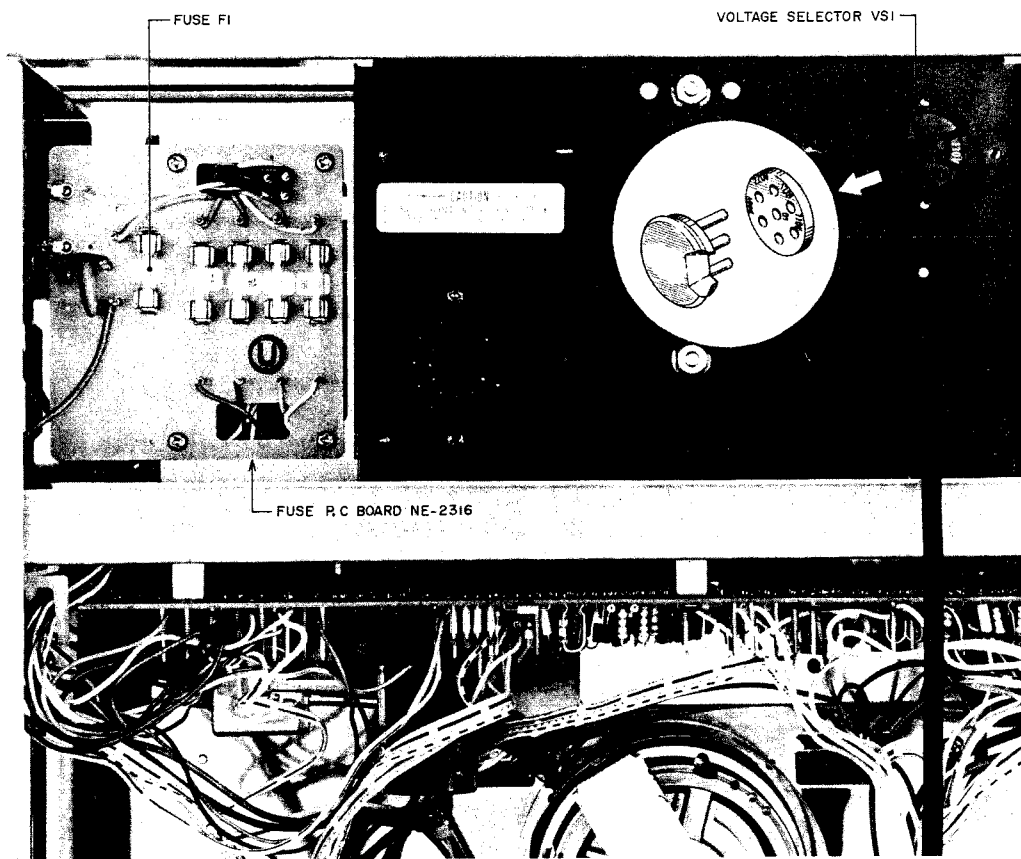

(b) U/T Model

Fig. 4 Voltage Conversion

## 1. VOLTAGE CONVERSION (Refer to Fig. 4)

### 1) JPN Model (100V 50/60 Hz)

Voltage can not be switched.

### 2) CSA Model (120V 60 Hz)

Voltage can not be switched.

### 3) CEE, UK Model (220/240V, 50 Hz)

A voltage selector switch is provided under the AC inlet on the back side of machine. Select the proper voltage by this switch according to the voltage to be used. Move the switch to the left side for 220V and to the right side for 240V.

### 4) U/T Model (110/120/220/240V, 50/60 Hz)

Remove the back board and find out the voltage selector and Fuse P.C Board on the upper portion of the machine. Change the position of voltage selector plugs so that the voltage to be used coincides with the voltage shown through the opening of voltage selector plug.

The rating of fuse (F1) differs depending on the voltage to be use. Change the fuse according to the specified rating shown below.

110/120V Area	125V 2A
220/240V Area	125V 1A

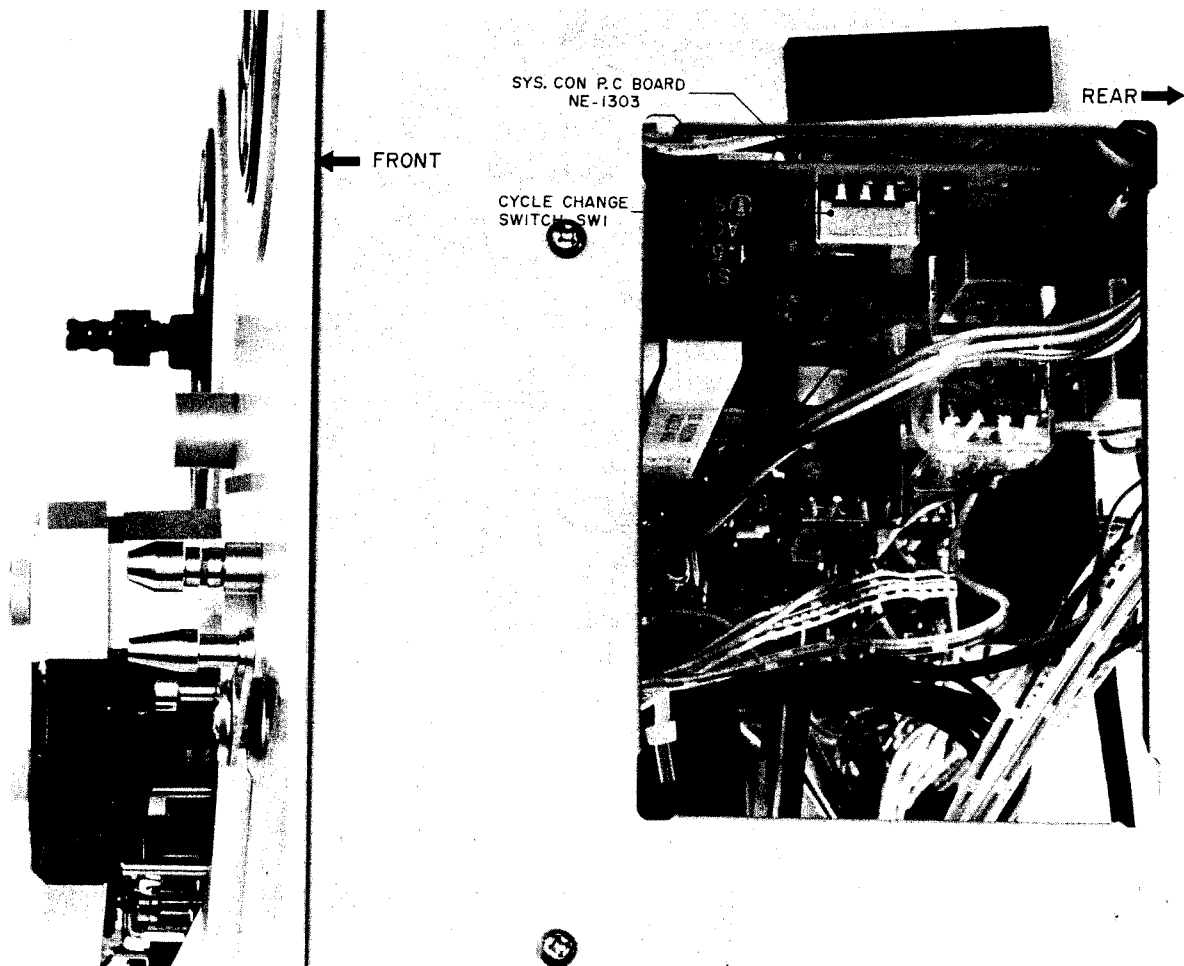

Fig. 5 Cycle Conversion

## 2. CYCLE CONVERSION (Refer to Fig. 5)

Cycle conversion can be made only with U/T, JPN Model.

Remove the right side board and the side cover therein and the cycle change switch will be found through the hole at the center of the mecha side plate as shown in Fig. 5. Change over this switch according to the frequency of the power supply available. Moving the switch lever to the right (rear) and to the left (front) will set the GX-266II to 50 and 60 Hz, respectively.

**Caution:** When selecting the voltage or cycle, make sure to turn off the power switch and disconnect the power cord.

# VI. CIRCUIT OPERATING PRINCIPLES

## 1. CIRCUIT CONSTRUCTION OF IC1 M54410P

The design of M54410P until now had STOP, PLAY, REC, FF, RWD, PAUSE and REC preventing AR as its input terminals. GX-266II circuit is constructed with FWD in place of PAUSE and REV in place of PLAY.

### 1) Block Diagram

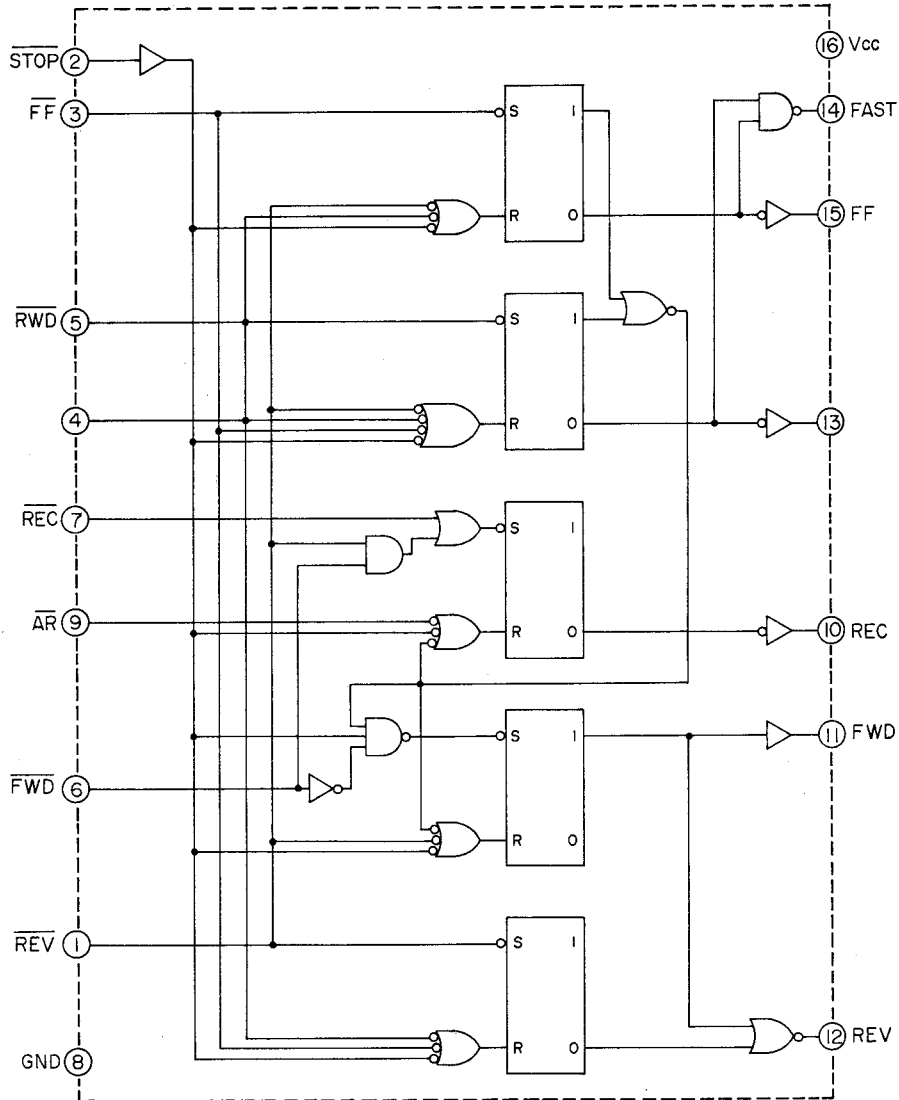

Fig. 6 M54410P

## 2) Terminals and their functions

	Terminal Name	Terminal Function
Operation input terminals	$\overline{\text{STOP}}$	Input terminal for stopping operation
	$\overline{\text{FF}}$	Input terminal for fast forward
	$\overline{\text{RWD}}$	Input terminal for rewind
	$\overline{\text{FWD}}$	Input terminal for playback in the forward direction
	$\overline{\text{REV}}$	Input terminal for playback in the reverse direction
	$\overline{\text{REC}}$	Input terminal for recording
Control input terminal	$\overline{\text{AR}}$	Input terminal for preventing recording
Output terminals	FAST	Terminal with "H" signal output during fast forward or rewind mode
	FF	Terminal with "H" signal output during fast forward mode
	FWD	Terminal with "H" signal output during forward playback mode
	REV	Terminal with "H" signal output during reverse playback mode
	REC	Terminal with "H" signal output during recording or REC/Pause mode

Chart-1

## 3) Operation activated by each input

Input Signal	Output					Output Mode
	FAST	FF	FWD	REV	REC	
$\overline{\text{STOP}}$	L	L	L	L	L	STOP Mode
$\overline{\text{FF}}$	H	H	L	L	L	FF Mode
$\overline{\text{RWD}}$	H	L	L	L	L	RWD Mode
$\overline{\text{FWD}}$	L	L	H	L	L	FWD Mode
$\overline{\text{REV}}$	L	L	L	H	L	REV Mode
$\overline{\text{REC}}/\overline{\text{FWD}}$	L	L	H	L	H	REC/FWD Mode
$\overline{\text{REC}}/\overline{\text{REV}}$	L	L	L	H	H	REC/REV Mode

Chart-2

- NOTES:**
1. The input signal is activated by the fall of  $\downarrow$ .
  2. The output is maintained until the next input signal.
  3.  $\overline{\text{AR}}$  is a control input terminal and the REC output is not "H" when  $\overline{\text{AR}} = \text{"L"}$ .
  4. When  $\overline{\text{AR}} = \text{"L"}$  signal is supplied during the REC output is "H", REC output becomes "L".
  5. At the moment the power is on, all output will be "L" and the Stop mode will be effected.

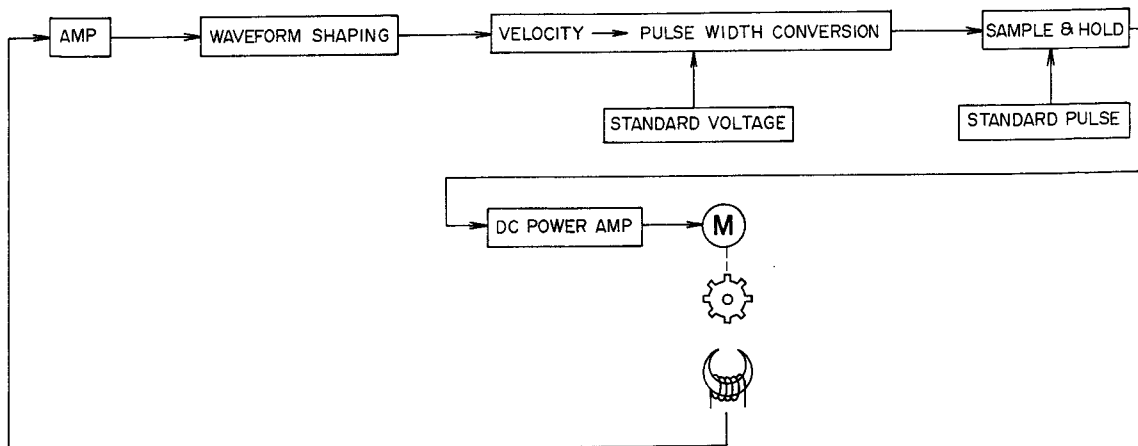

Fig. 7 Block Diagram

#### 4) Regarding the input circuit's diode D31

Previously M54410P has been so designed that the first terminal was  $\overline{\text{PLAY}}$  input and the sixth terminal was  $\overline{\text{PAUSE}}$  input.

But in GX-266II  $\overline{\text{PLAY}}$  is used for  $\overline{\text{REV}}$  and  $\overline{\text{PAUSE}}$  for  $\overline{\text{FWD}}$ .

Consequently, grounding only the 6th terminal ( $\overline{\text{FWD}}$ ) will not allow the modes to be changed directly from FF or RWD to FWD.

For this reason, the first terminal ( $\overline{\text{REV}}$ ) is also grounded through diode D31 releasing FF and RWD. In addition, even if there are simultaneous inputs into both  $\overline{\text{FWD}}$  and  $\overline{\text{REV}}$ , FWD mode output is designed to take priority.

## 2. THE SAMPLE AND HOLD SYSTEM SERVO MOTOR (SCM-200) OPERATION

- 1) Servo signals generally created proportionately to the number of revolutions of the motor are shown either as frequency deviations or voltage deflections. The motor employed in GX-266II uses frequency deviation unaffected by time constants, etc., of the load circuit as input signal to the motor drive circuit through pulse width conversion.

This pulse width varies proportionately to the deviations in the number of motor rotations. The deviation is detected, converted to a voltage value, is held at that voltage until the next servo signal pulse, and then impressed into the motor drive circuit.

Meanwhile, since it requires a holding circuit and because 112 pulse are generated for each motor rotation, time constants of circuits coming before the Sample and Hold circuit can be greatly reduced compared to the conventional voltage deflection detection system.

For the reasons above, it features quick response to motor revolutions, minimum influence by temperature, and fewer chances of faulty mechanism. In addition, due to the inclusion of the servo voltage holding circuit, ripple content of the servo voltage holding circuit, ripple content of the servo voltage has been sharply reduced to result in a smooth and stable tape transport with a minimum of wow & flutter.

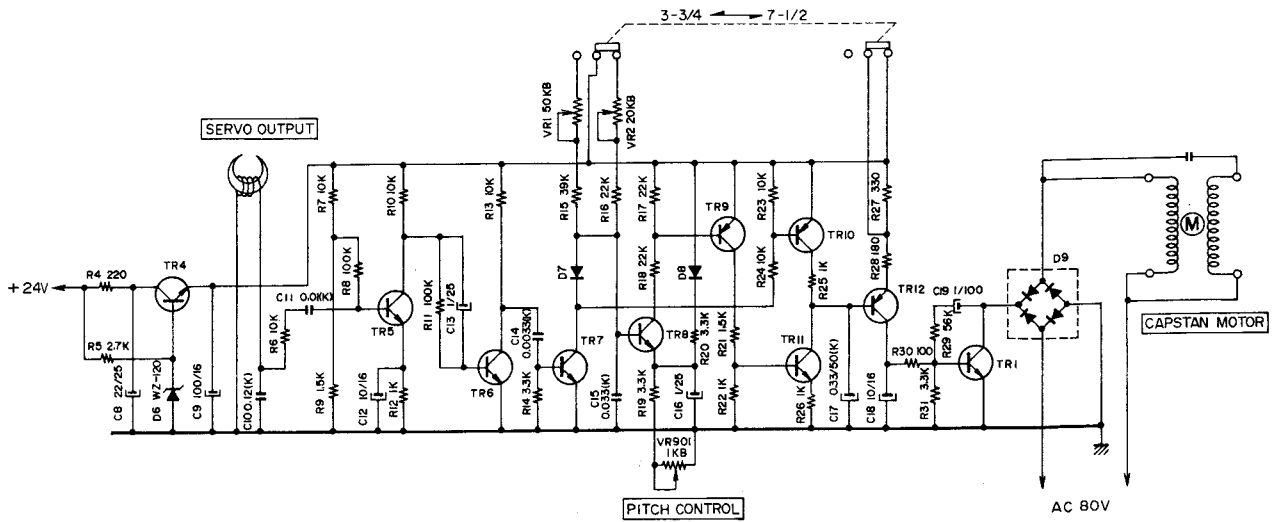

Fig. 8

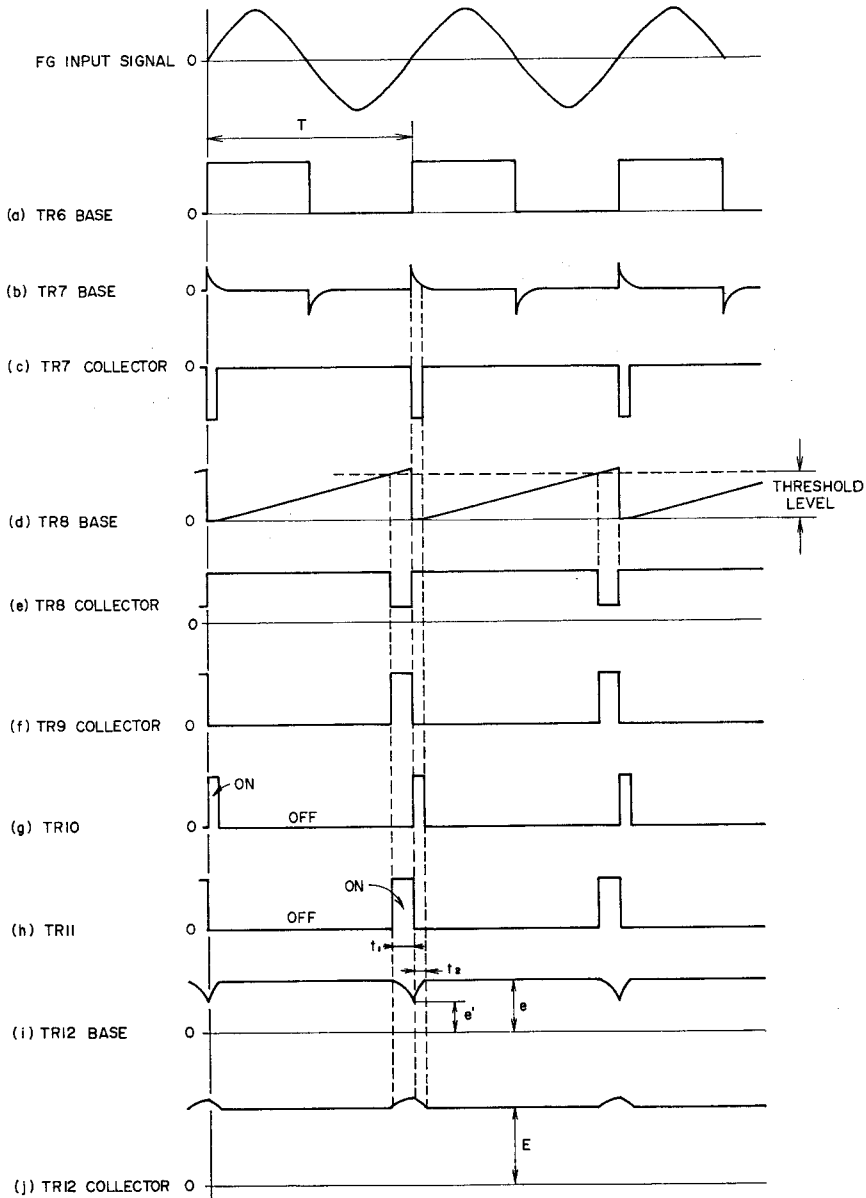

Fig. 9



## 2) Explanation of the circuit operation

(Refer to Figs. 8, 9)

The velocity signal obtained from the motor's frequency generator is shaped into a waveform in the period of "T" proportionate to the velocity as in (a) on collector TR6. This signal is differentiated and enters TR7 base. This makes TR7's collector output as in (c) and turns ON TR10 during the time of the negative pulse.

Meanwhile TR8 base is supplied with a waveform like (d) and when it reaches the threshold level, TR8 is turned on. A waveform (e) with pulse width " $t_1$ " is obtained from the collector. During the time "T" that TR8 is ON, TR9 base electric potential decreases to turn ON.

Consequently, TR11 base electric potential increases and TR11 is also turned ON for the time " $t_1$ ".

When the period "T" varies with the velocity, the pulse width " $t_1$ " varies according to TR8's threshold level. But when TR10 is on, it is constant due to the time constant. So that by using the period that TR10 is ON as the standard pulse, the pulse width " $t_2$ " is constant regardless of the velocity. (g) and (h) show the ON and OFF condition of TR10 and TR11. When the electric charge that was charged to C17 is discharged during the time TR11 is ON " $t_1$ ", a signal voltage of "e" proportionate to the velocity can be obtained. Next, with "e" as its basis, C17 is charged during the limited time of the standard pulse width " $t_2$ ", and by the charging voltage "e" the charging is stopped.

The voltage is then held until the next standard pulse.

This voltage "e" is supplied to the TR12 base and a servo signal "E" is obtained. This servo signal "E" controls TR1 and drives the motor. As shown above, since " $t_1$ " and " $t_2$ " are small, servo signal ripples are made small and a near direct current servo signal is obtained.

In addition, the time constants of the smoothing circuit can also be made small that phase lag factor can be minimized.

## VII. MECHANICAL ADJUSTMENT

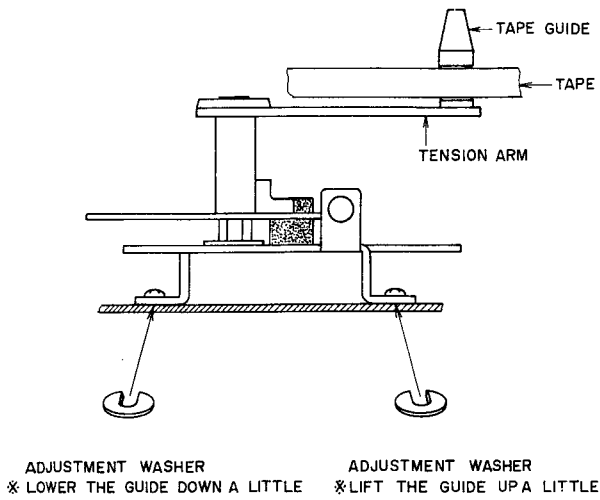

Fig. 10

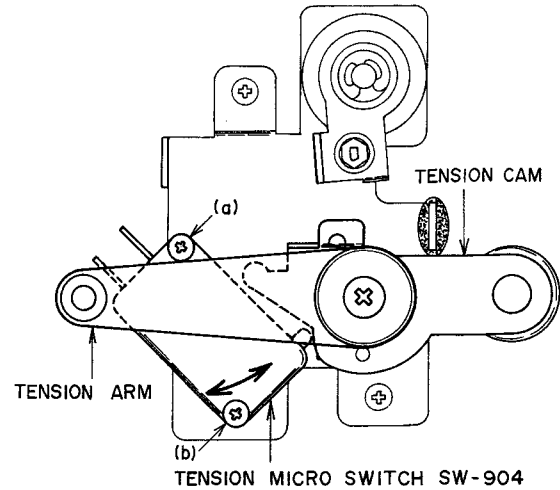

Fig. 11

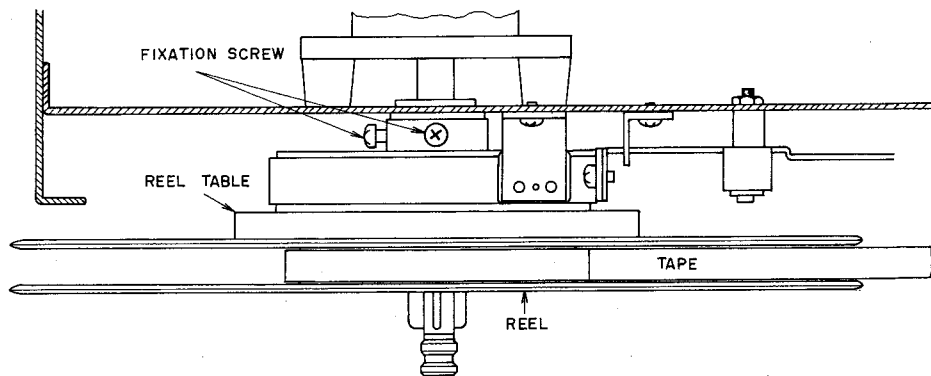

Fig. 12

### 1. TAPE GUIDE HEIGHT ADJUSTMENT

(Refer to Fig. 10)

As shown in Fig. 10, insert a U-washer between the mecha frame and the tension arm table and adjust the height of both right and left tape guides so that the tape will run smoothly in either FWD or REV mode without being twisted or caught by the tape guides.

### 2. TENSION MICROSWITCH POSITION

ADJUSTMENT (Refer to Fig. 11)

Loosen fitting screw (a) and (b) and adjust the position of the tension micro switch so that the tension arm will move about 3 mm at the top until it is released after the micro switch has been opened, when the tension arm once raised is gradually lowered.

Also adjust the position of the tension micro switch so that the tension cam does not rub against the micro switch body.

### 3. REEL TABLE HEIGHT ADJUSTMENT

(Refer to Fig. 12)

1) Load a tape and set the deck to F.FWD and RWD modes.

Adjust Reel Table height so that the tape winds on the center of the reels at both modes.

2) Tape should wind on center of reel regardless of type of reel used.

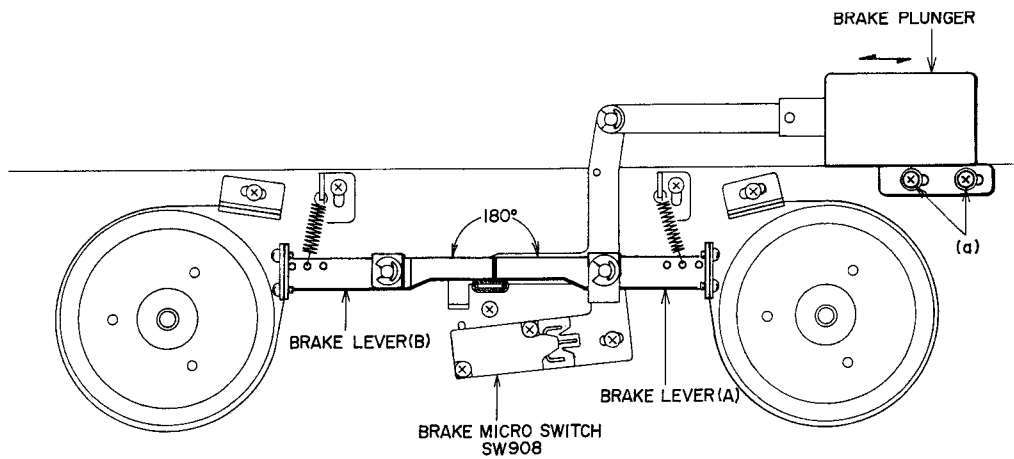

Fig. 13

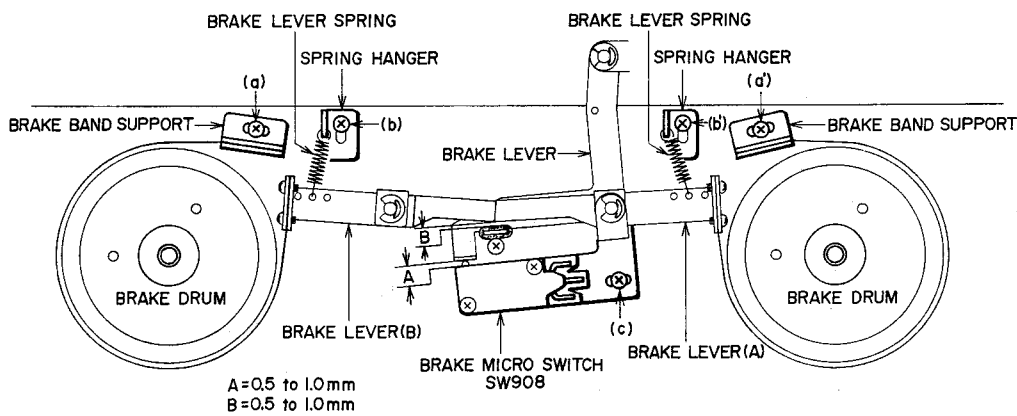

Fig. 14

#### 4. BRAKE PLUNGER INSTALLATION POSITION ADJUSTMENT (Refer to Fig. 13)

With the brake plunger in operation (in FWD or FF mode), loosen fitting screw (a) and adjust the position of the brake plunger so that brake lever (A) will be in line with brake lever (B).

#### 5. BRAKE MICRO SWITCH INSTALLATION POSITION ADJUSTMENT (Refer to Fig. 14)

To adjust the brake micro switch installation position, loosen the fitting screw (c) so that clearance A between the brake micro switch and the brake lever will be 0.5 thru 1.0 mm in the STOP mode (with the brake plunger released).

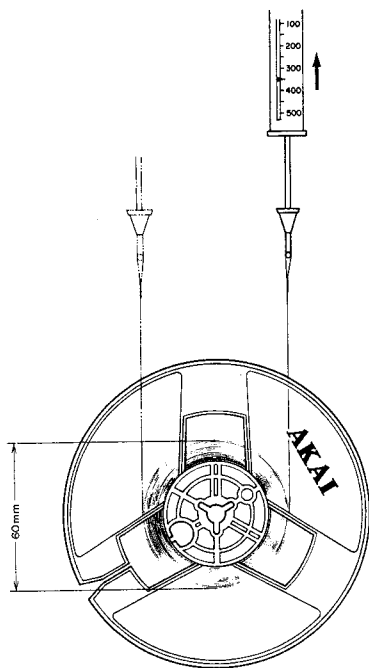

Fig. 15

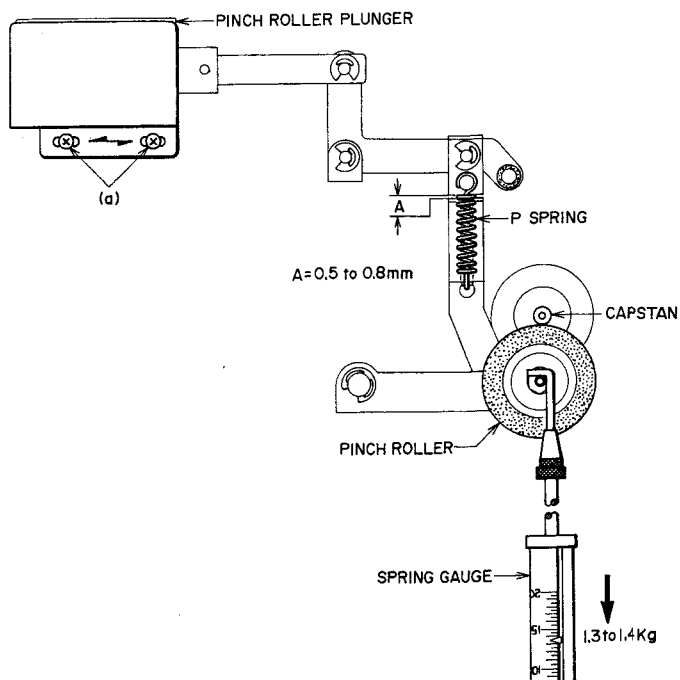

Fig. 16

## 6. BRAKE BAND POSITION AND BRAKE TENSION ADJUSTMENT

(Refer to Figs. 14, 15)

- 1) Remove the reel table from the brake drum.
- 2) Loosen screws (a) and (a') and adjust brake band support position so that clearance B between the brake lever and brake lever (A) and (B) will be 0.5 thru 1.0 mm in the STOP mode (with the brake plunger released).
- 3) Put the brake plunger in operation and make sure that there is a clearance between the cloth on the outer circumference of the brake drum and the brake band.
- 4) Install the reel table onto the brake drum.
- 5) Loosen screws (b) and (b') and adjust the spring hanger position so that both right and left brakes will have a tension of 350 thru 400 g in the STOP mode (with the brake plunger released).  
If the specified brake tension cannot be obtained, hook the spring in another hole of the brake lever all over again to carry out the adjustment. (Use a 500 g spring gauge for a reel with 60 mm diameter of tape.)

## 7. PINCH ROLLER PLUNGER INSTALLATION POSITION AND PINCH ROLLER PRESSURE ADJUSTMENT

(Refer to Fig. 16)

- 1) Loosen the screw (a) and adjust the pinch roller plunger position so that clearance A will be 0.5 thru 0.8 mm in the FWD or REV mode.
- 2) Remove the pinch roller cap and put the system in the FWD or REV mode. With a spring gauge connected to the pinch roller fixing screw, separate the pinch roller about 1 or 2 mm away from the capstan and return it gradually. When the pinch roller comes in touch with the capstan and begins turning, read the spring gauge.  
The specified Pinch Roller pressure is 1,30 thru 1,400 g.  
If the specified pressure cannot be obtained, adjust clearance A by positioning the pinch roller plunger or replace the pinch roller spring, so as to attain the specified pressure force.

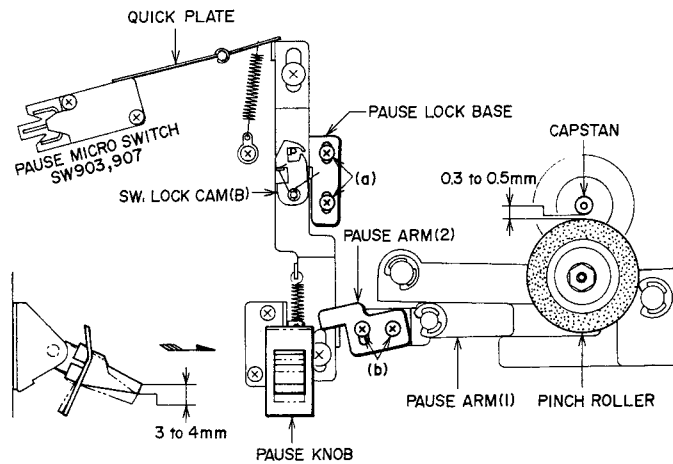

Fig. 17

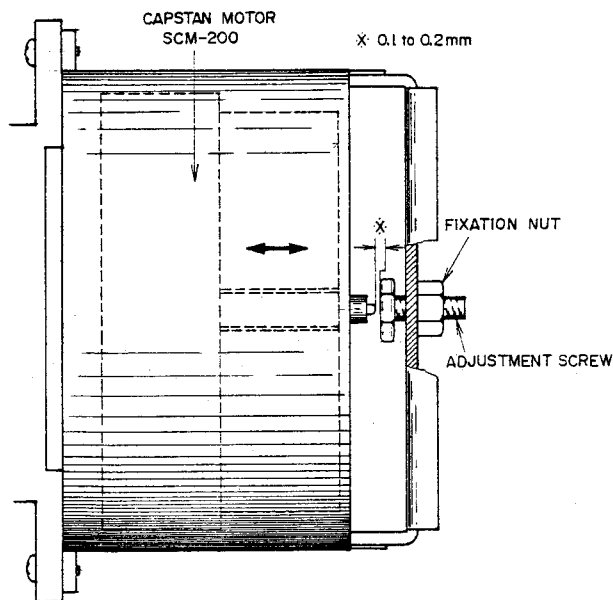

Fig. 18

## 8. PAUSE MECHANISM ADJUSTMENT

(Refer to Fig. 17)

- 1) Loosen screw (a) and adjust the pause mechanism by moving the pause lock base so that the PAUSE knob will return about 3 thru 4 mm at the top when released after fully pushed up by finger.
- 2) Manipulate the PAUSE knob several times and confirm that switch lock cam (B) performs locking and releasing without fail. Unless the cam operates stably, re-adjust the position of the pause lock base.
- 3) Loosen screw (b) and change the angle between pause arms (1) and (2) so that pinch roller will have a clearance of 0.3 thru 0.5 mm against the capstan when the FWD or REV mode is changed over to the PAUSE mode.
- 4) Bend the quick plate so that it does not fail to push the pause micro switch in the pause mode and the quick plate will leave the pause micro switch without fail when released from the pause mode.
- 5) In the FWD or REV mode, slowly depress the pause knob and confirm that the pause micro switch will be opened at the same time when or a little before the pinch roller leaves the capstan. If the micro switch operation timing is out of order, the tape will be loosened. In this case, re-adjust the quick plate. Adjust timing, if necessary, by repeating adjustment procedures 1) thru 4) above.

## 9. CAPSTAN SHAFT LOOSE PLAY

ADJUSTMENT (Refer to Fig. 18)

Adjust by turning adjustment screw to obtain a 0.1 to 0.2 mm degree of loose play when the capstan shaft is moved as indicated by the arrow mark. Tighten fixation nut to maintain optimum adjusted condition.

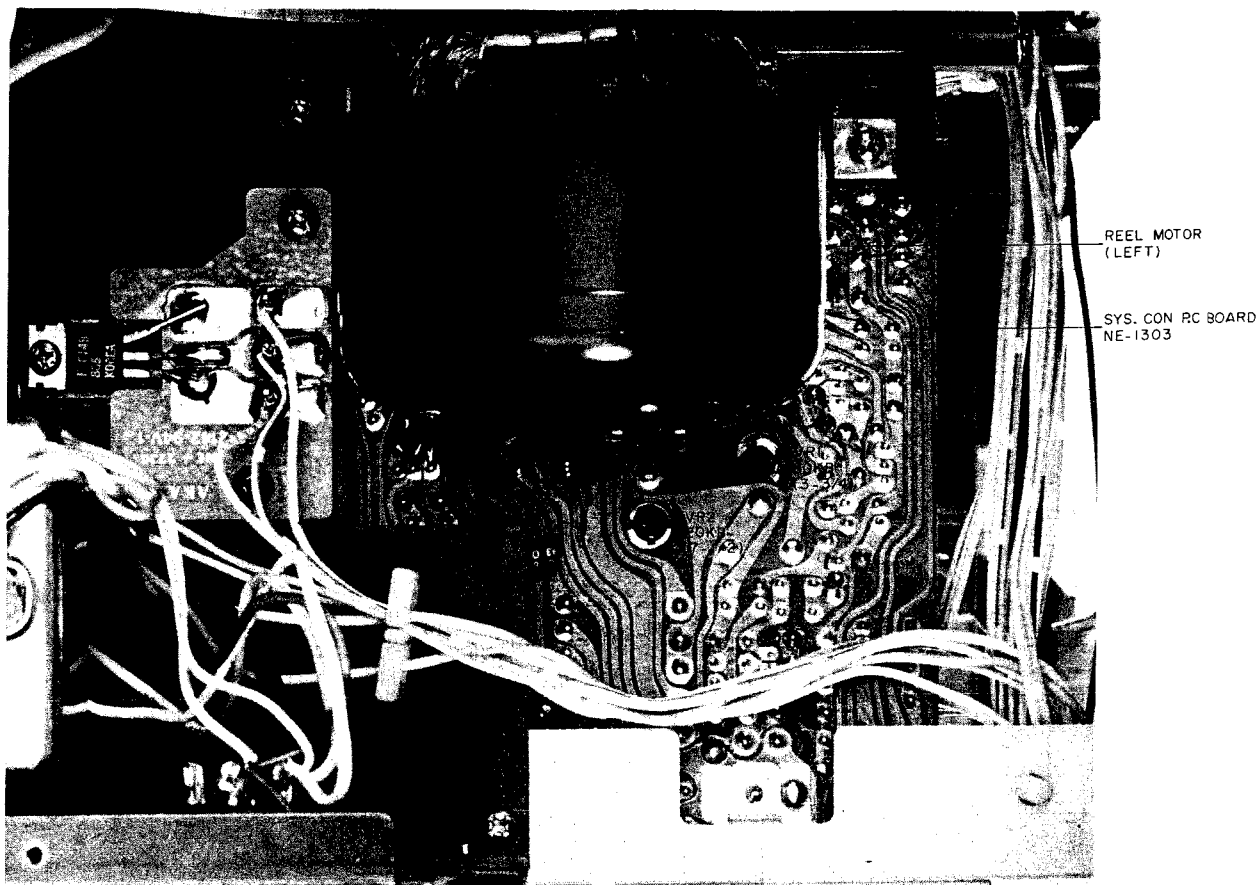

Fig. 19

## 10. TAPE SPEED ADJUSTMENT

(Refer to Fig. 19)

Set the Tape Speed Switch to 7-1/2 ips and playback the 1,000 Hz, 7-1/2 ips Test Tape. Connect a frequency counter to LINE OUT and adjust VR2 20 k $\Omega$  until the counter reads 1,000 Hz  $\pm$  0.5%.

Next, set the Tape Speed Switch to 3-3/4 ips and adjust VR1 50 k $\Omega$  until the frequency counter reads 500 Hz  $\pm$  0.5%.

# VIII. HEAD ADJUSTMENT

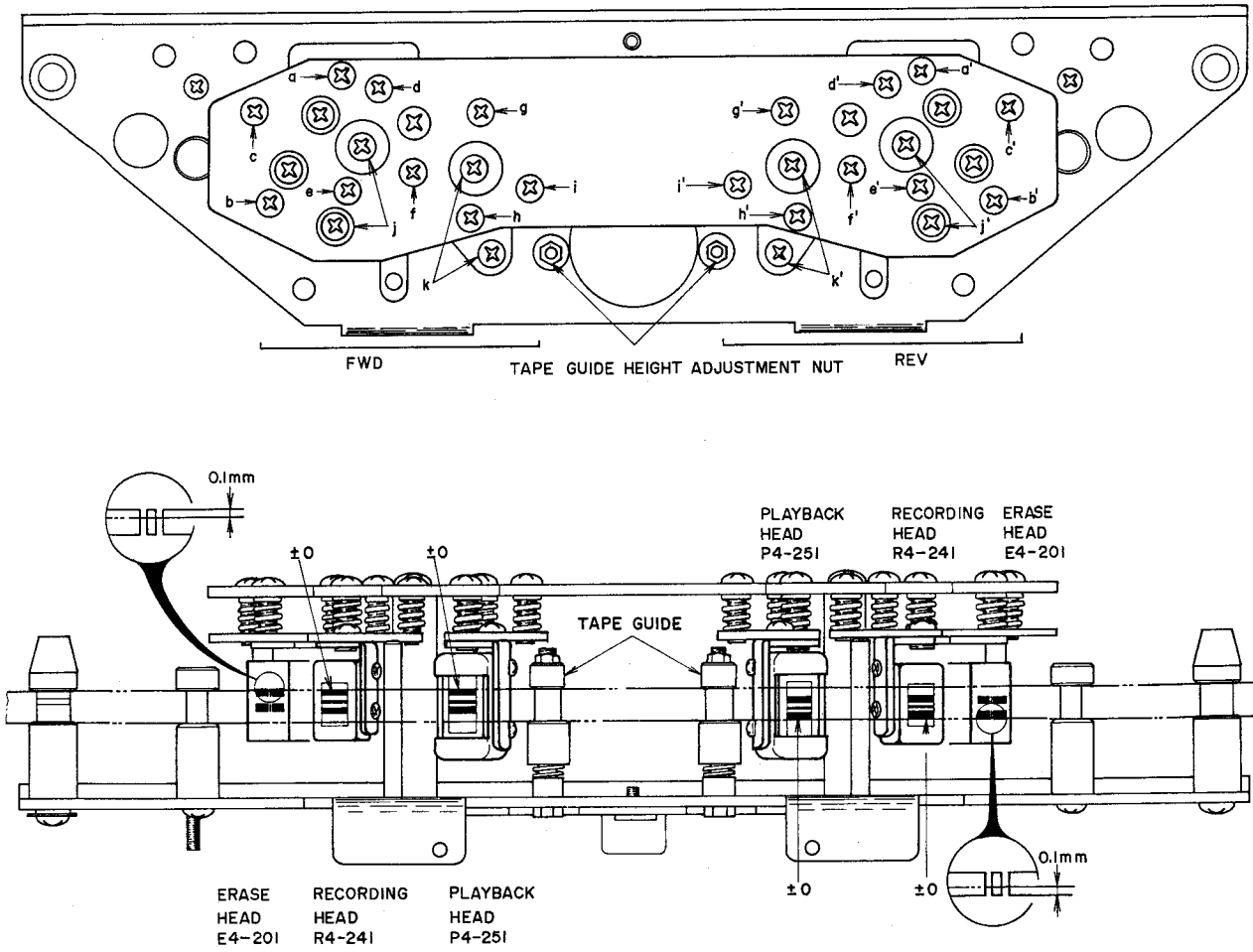

Fig. 20

Step	Adjustment Item	Test Tape Supply Signal	Mode	Adjustment Point	Remarks
1	Tape Guide Height	Optional	FWD	Tape Guide Height Adjustment Nut	Adjust so that tape travels smoothly and does not twist.
2	FWD Erase Head Height	Optional	FWD	(a) (b) (c)	Upper edge of Left Ch. head core is 0.1 mm higher than upper edge of tape.
3	FWD Recording Head Height	Optional	FWD	(d) (e) (f)	Upper edges of Left Ch. head core and tape are the same height.
4	FWD Playback Head Height	Optional	FWD	(g) (h) (i)	Upper edges of Left Ch. head core and tape are the same height.
5	FWD Playback Head Azimuth Alignment	8,000 Hz 3-3/4 ips Test Tape	FWD	(i)	Maximum output, both channels.
6	FWD Playback Head Angle Alignment	8,000 Hz 3-3/4 ips Test Tape	FWD	(k)	Adjust head gap surface so that there is no change in output level when tension is applied to the supply reel side.
7	FWD Recording Head Azimuth Alignment	Scotch #176 Tape 15,000 Hz -20 dBm	REC	(f)	Maximum output, both channels.
8	FWD Recording Head Angle Alignment	Scotch #176 Tape 15,000 Hz -20 dBm	REC	(j)	Adjust head gap surface so that there is no change in output level when tension is applied to the supply reel side.

Chart-3

- NOTES:**
- 1) As perfect head adjustments are vital to tape deck performance, be sure that these adjustments are carried out properly.
  - 2) Be careful not to use a magnetized driver or other magnetized tools in the vicinity of the heads.
  - 3) Use only new tape as level variation is likely to occur when using old tape.
  - 4) Demagnetize heads with head demagnetizer before and after head adjustment.
  - 5) Set tape speed to 7-1/2 ips.
  - 6) Adjustments outlined in Chart-1 are only for FWD side heads. However, Adjustments for REV side, heads are exactly the same.



## IX. AMPLIFIER ADJUSTMENT

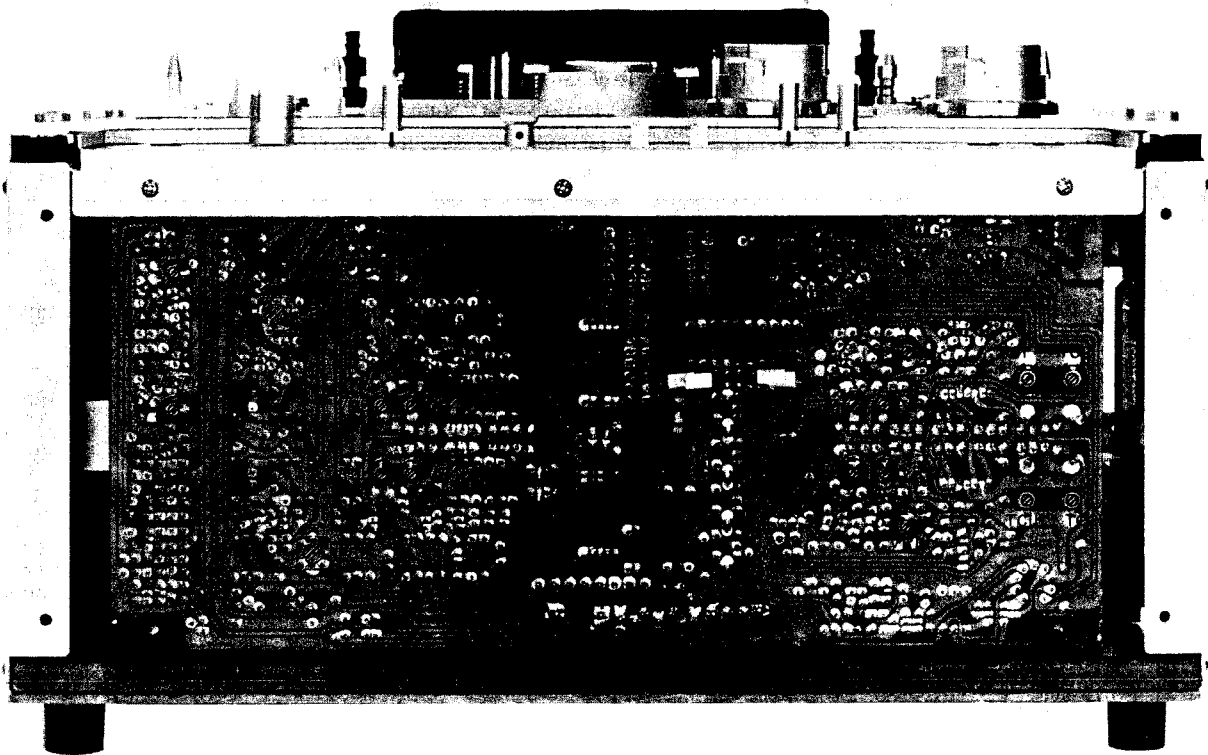

Fig. 21

VR4	50 kB	FWD Playback Level Adjustment
VR5	50 kB	REV Playback Level Adjustment
VR7	1 kB	VU Meter Sensitivity Adjustment
VR1	5 kB	Monitor Level Adjustment
VR2	10 kB	FWD Recording Level Adjustment
VR3	10 kB	REV Recording Level Adjustment
TC2	80 PF	FWD Frequency Response Adjustment
TC1	80 PF	REV Frequency Response Adjustment
L8	23 mH	Bias Filter Adjustment

\* The letter "b" following an adjustment part number indicates "RIGHT CHANNEL".

Step	Adjustment Item	Test Tape Supply Signal	Mode	Adjustment Point	Result	Remarks
1	FWD Playback Level	700 Hz 7-1/2 ips 0VU Test Tape	FWD	VR4 50 kB	0±0.5 dBm (0.775V)	
2	REV Playback Level	700 Hz 7-1/2 ips 0VU Test Tape	REV	VR5 50 kB	0±0.5 dBm (0.775V)	
3	VU Meter Sensitivity	700 Hz 7-1/2 ips 0VU Test Tape	FWD	VR7 1 kB	0VU indication	
4	Monitor Level	1,000 Hz -21 dBm Signal to Line Input	STOP	VR1 5 kB	0 dBm (0VU)	Line REC Volume maximum, Monitor Switch "SOURCE"
5	FWD Recording Level	Scotch #176 Tape 1,000 Hz 0 dBm Recording	FWD-REC	VR2 10 kB	0±0.5 dBm (0.775V)	
6	REV Recording Level	Scotch #176 Tape 1,000 Hz 0 dBm Recording	REV-REC	VR3 10 kB	0±0.5 dBm (0.775V)	
7	FWD Frequency Response	Scotch #176 Tape 1.5 kHz, 15 kHz -20 dBm Recording	FWD-REC	TC2 80 PF	1.5 kHz 15 kHz Flat	Tape speed 3-3/4 ips. Recheck Recording Level.
8	REV Frequency Response	Scotch #176 Tape 1.5 kHz, 15 kHz -20 dBm Recording	REV-REC	TC1 80 PF	1.5 kHz 15 kHz Flat	Tape Speed 3-3/4 ips. Recheck Recording Level.
9	FWD Distortion Confirmation	Scotch #176 Tape 1,000 Hz 0 dBm Recording	FWD-REC		Less than 0.5%	See NOTE 4.
10	REV Distortion Confirmation	Scotch #176 Tape 1,000 Hz 0 dBm Recording	REV-REC		Less than 0.5%	See NOTE 4.
11	Bias Filter		REC	L8 23 mH	Less than -30 dB	Mic, Line REC Volume at Max. See NOTE 5.

Chart -4

- NOTES:**
- 1) Output Level Control should be at maximum.
  - 2) Except for Steps 7 and 8, set Tape Speed to 7-1/2 ips.
  - 3) Set Tape Selector Switch to Low Noise position.
  - 4) If it does not comply with the specifications, repeat Steps 7 and 8, and re-adjust.
  - 5) Unless the core is moved intentionally this adjustment is not necessary.

## X. DC RESISTANCE OF VARIOUS COILS

Part	Designation	DC Resistance
Main Motor	SCM-200	Between BLU-RED : 110 ohms Between YLW-BRN : 170 ohms Pick-up Coil : 665 ohms
Reel Motor	24XO-MR	Between BLU-RED : 74 ohms Between YLW-BRN : 166 ohms
Pinch Roller Plunger	1660PHT-3	700 ohms $\pm$ 10%
Brake Plunger REV Plunger	1240PLTI	600 ohms $\pm$ 10%
Relay	LCIN-JT DC 24V	1,600 ohms $\pm$ 10%
Relay	FRL-264	650 ohms $\pm$ 15%
Relay	BR211	1,280 ohms $\pm$ 10%
Relay	L 24	1,600 ohms $\pm$ 10%
Erase Head	E4-201	1.8 ohms
Recording Head	R4-241	5.9 ohms
Playback Head	P4-251	219 ohms $\pm$ 10%
Oscillator Coil	OT-204	Between 1-3 : 0.3 ohms Between 4-6 : 0.7 ohms Between 7-9 : 8.2 ohms

Chart-5

## XI. CLASSIFICATION OF VARIOUS P.C BOARDS

### 1. P.C BOARD TITLES AND IDENTIFICATION NUMBERS

P.C Board Title	P.C Board Number
Sys. Con P.C Board	NE-1303
Pre Amp P.C Board	NE-5301
Mic Amp P.C Board	NE-5223
Fuse P.C Board (U/T)	NE-2316
Fuse P.C Board (JPN)	NE-2317
Fuse P.C Board (CSA)	NE-2318
Fuse P.C Board (CEE, UK)	NE-2319
Operation P.C Board	NE-2239
Lamp P.C Board	NE-2229
Mute P.C Board	NE-2313
Terminal P.C Board	NE-2230

Chart-6

## 2. COMPOSITION OF VARIOUS P.C BOARDS

- 1) SYS. CON P.C BOARD NE-1303 (4ED), LAMP P.C BOARD NE-2229,  
MUTE P.C BOARD NE-2313 & TERMINAL P.C BOARD NE-2230

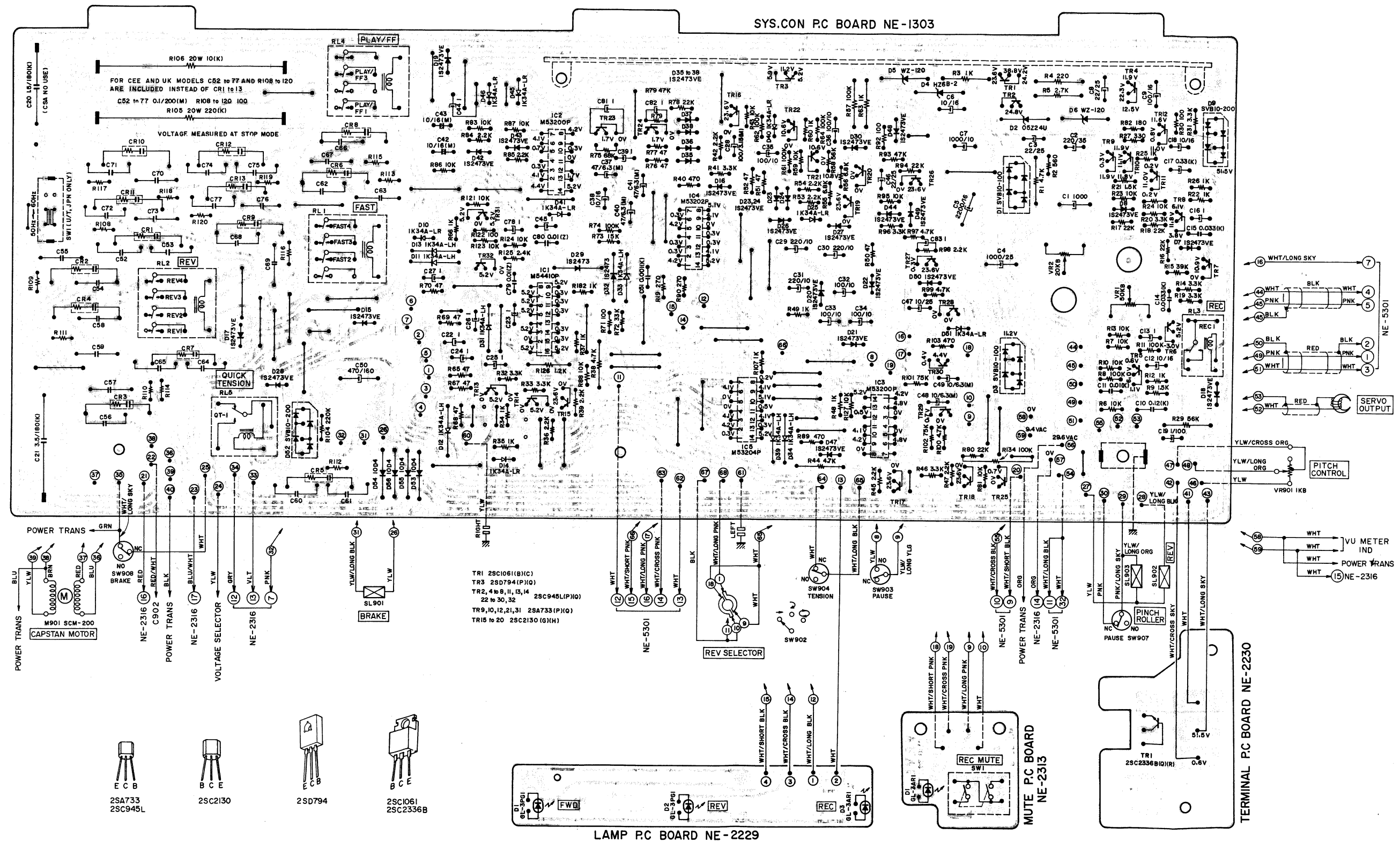

2) PRE AMP P.C BOARD NE-5301 (2ED)

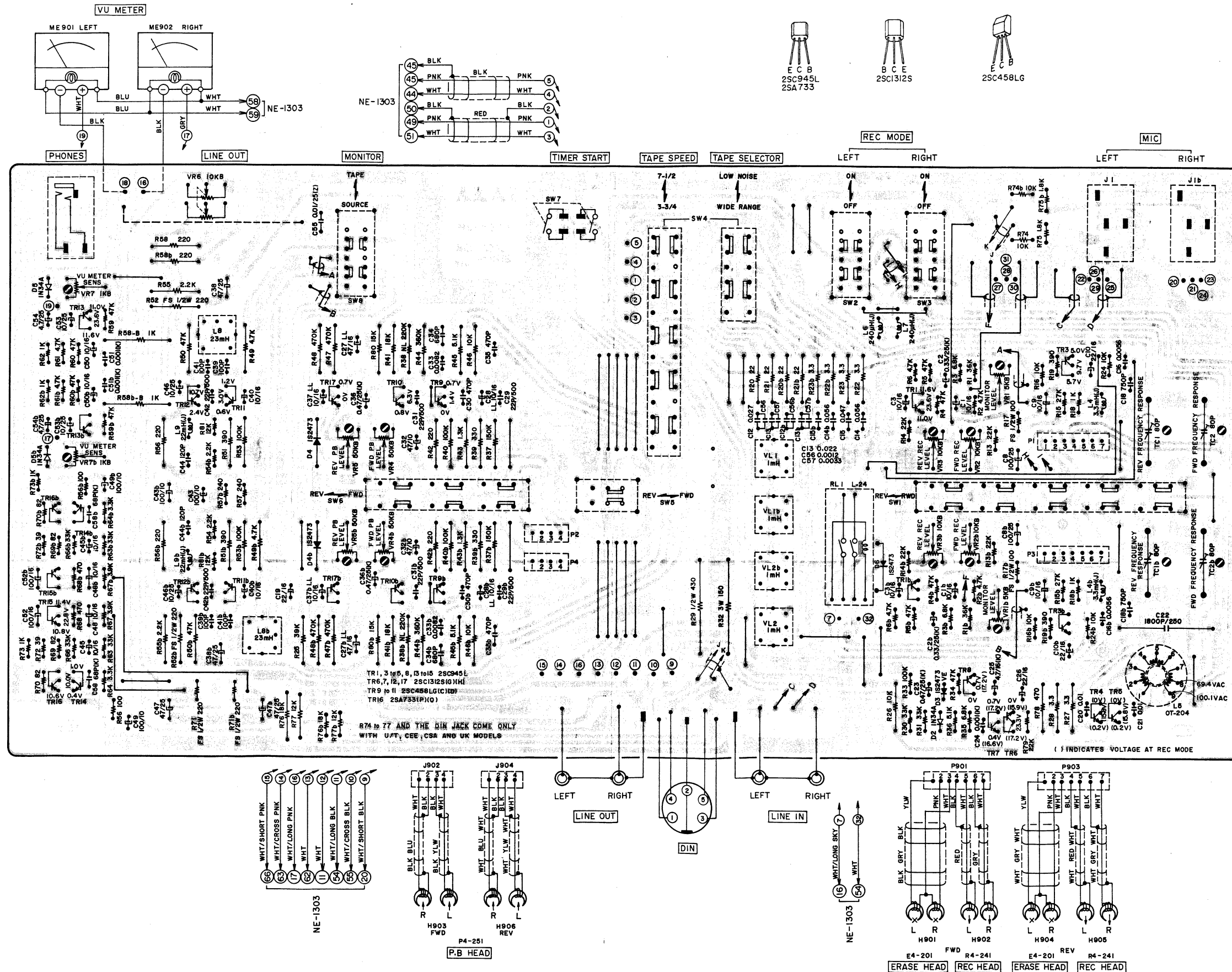

2) PRE AMP P.C BOARD NE-5301 (2ED)

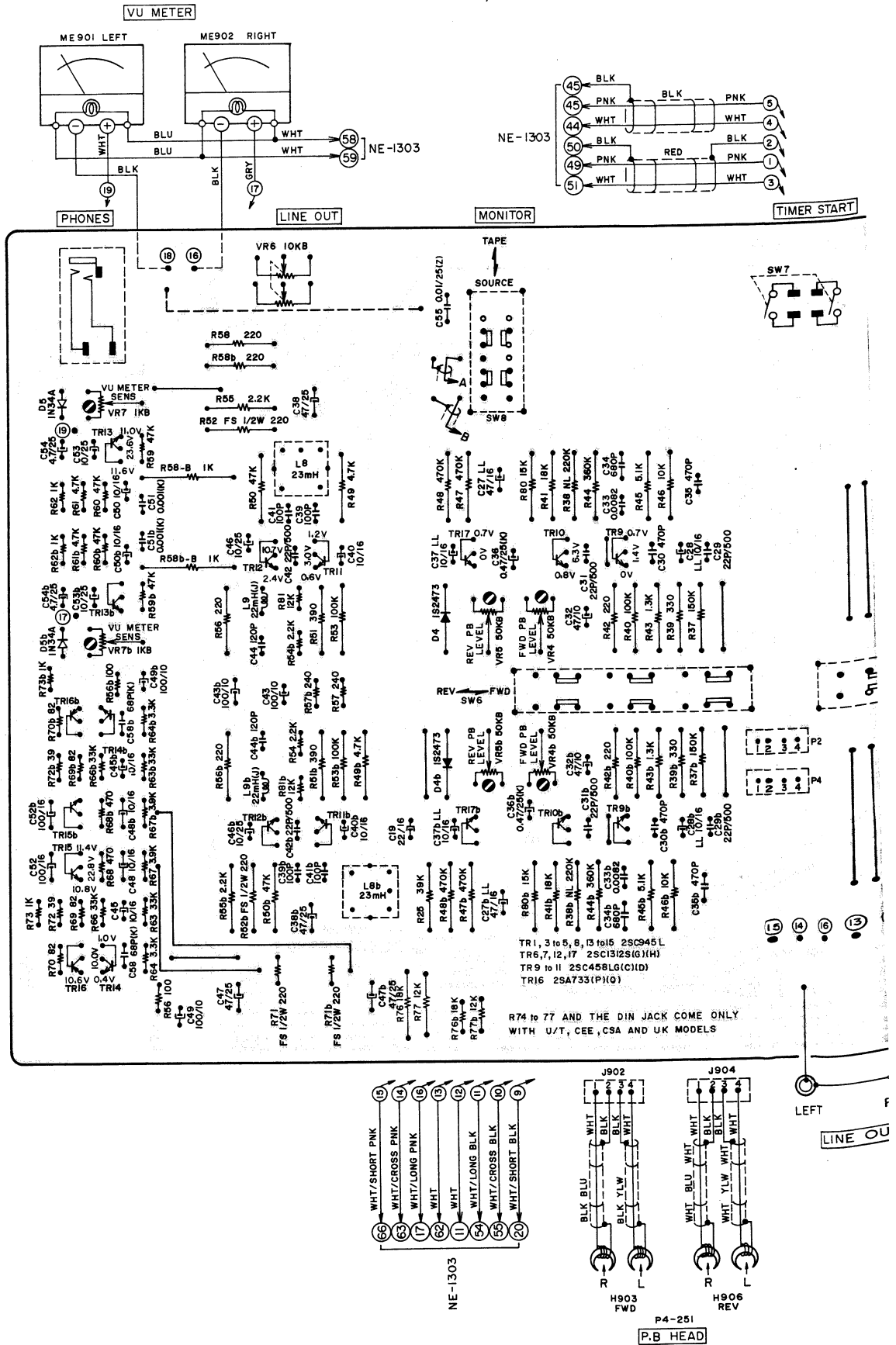

5) FUSE P.C BOARD (U/T) NE-2316

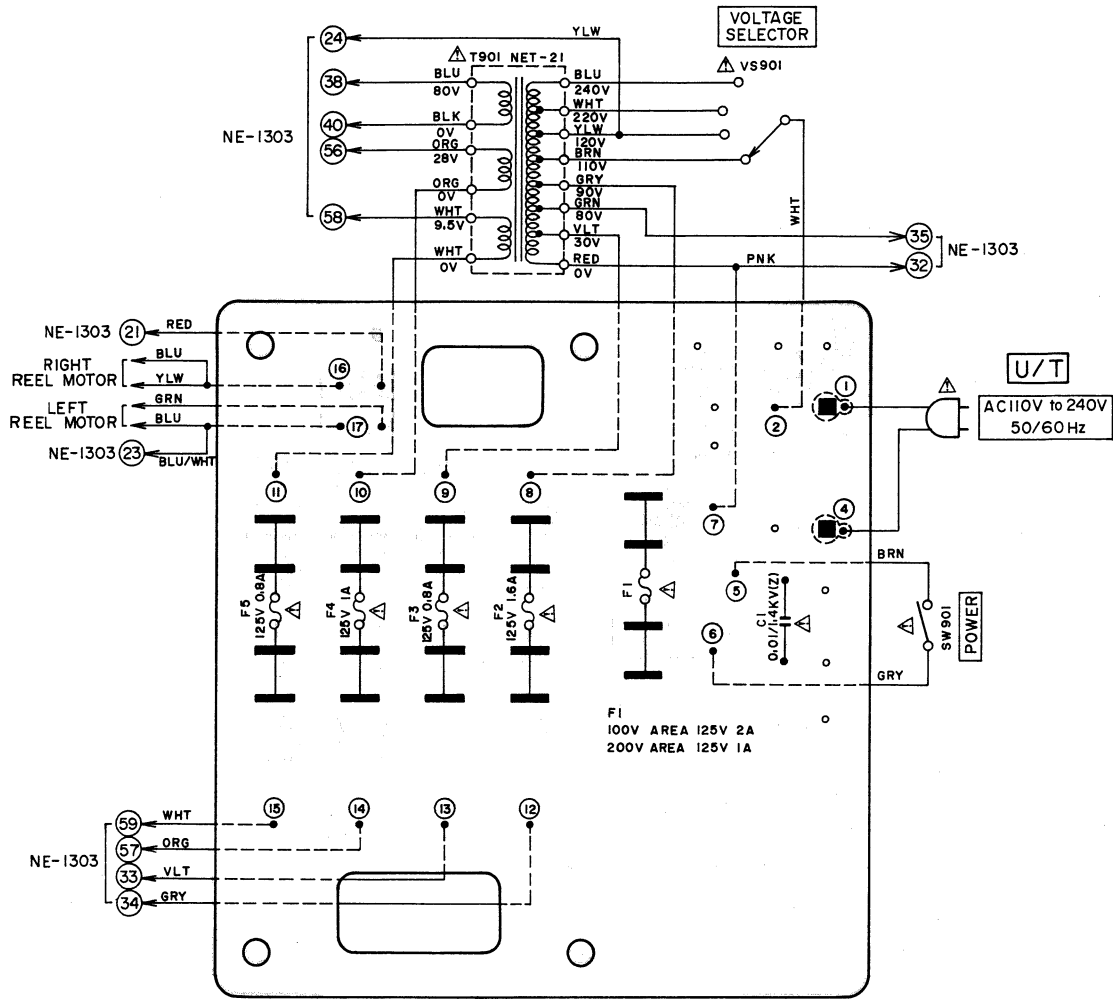

WARNING: Δ INDICATES SAFETY CRITICAL COMPONENTS. FOR CONTINUED SAFETY, REPLACE SAFETY CRITICAL COMPONENTS ONLY WITH MANUFACTURER'S RECOMMENDED PARTS.

AVERTISSEMENT: Δ IL INDIQUÉ LES COMPOSANTS CRITIQUES DE SÛRETÉ. POUR MAINTENIR LE DEGRÉ DE SÛRETÉ DE L'APPAREIL NE REMPLACER LES COMPOSANTS DONT LE FONCTIONNEMENT EST CRITIQUE POUR LA SÛRETÉ QUE PAR DES PIÈCES RECOMMANDÉES PAR LE FABRICANT.

6) FUSE P.C BOARD (JPN) NE-2317

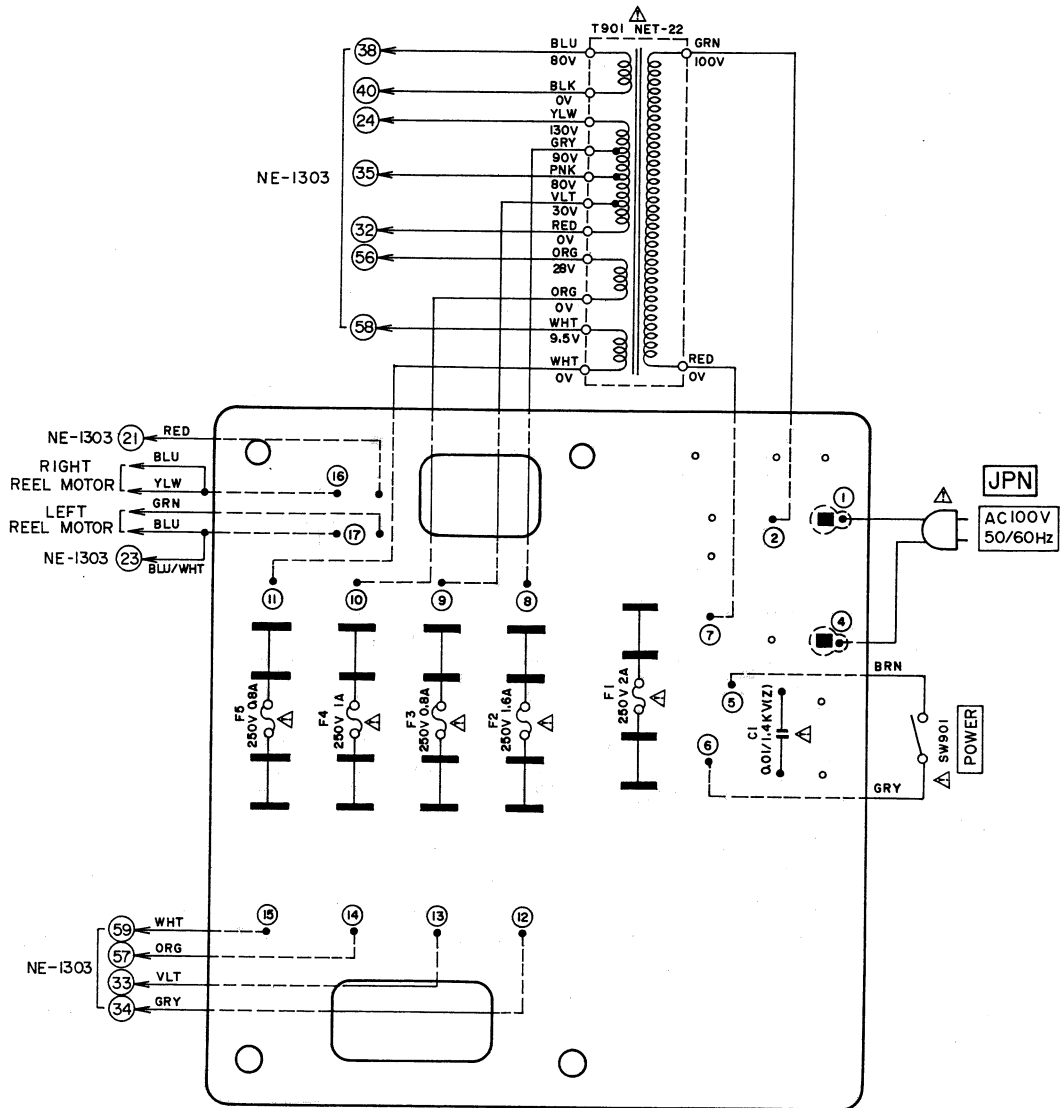

WARNING:  $\Delta$  INDICATES SAFETY CRITICAL COMPONENTS. FOR CONTINUED SAFETY, REPLACE SAFETY CRITICAL COMPONENTS ONLY WITH MANUFACTURER'S RECOMMENDED PARTS

AVERTISSEMENT:  $\Delta$  IL INDIQUE LES COMPOSANTS CRITIQUES DE SÛRETÉ. POUR MAINTENIR LE DEGRÉ DE SÛRETÉ DE L'APPAREIL NE REMPLACER LES COMPOSANTS DONT LE FONCTIONNEMENT EST CRITIQUE POUR LA SÛRETÉ QUE PAR DES PIÈCES RECOMMANDÉES PAR LE FABRICANT



7) FUSE P.C BOARD (CSA) NE-2318

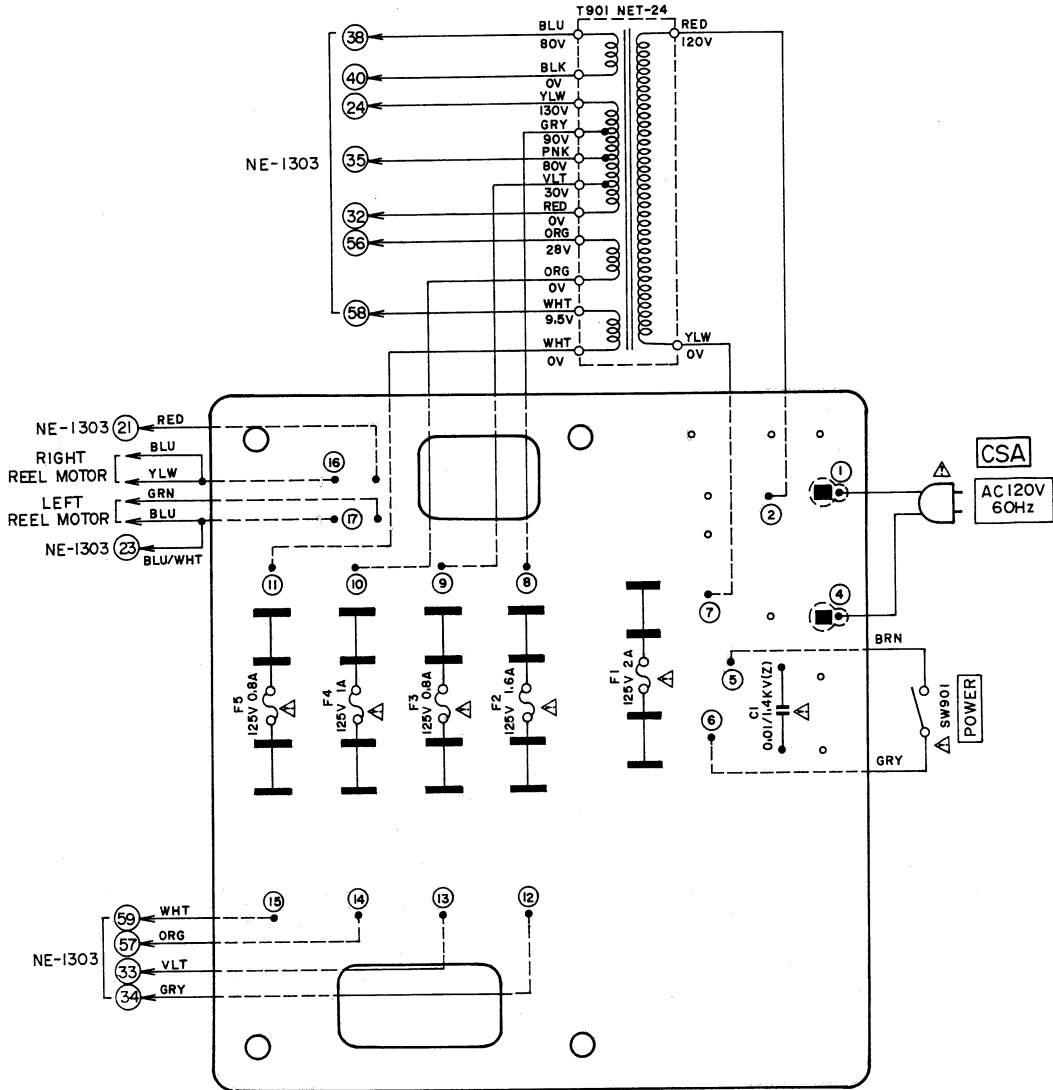

WARNING: Δ INDICATES SAFETY CRITICAL COMPONENTS. FOR CONTINUED SAFETY, REPLACE SAFETY CRITICAL COMPONENTS ONLY WITH MANUFACTURER'S RECOMMENDED PARTS  
 AVERTISSEMENT: Δ IL INDIQU LES COMPOSANTS CRITIQUES DE SÛRETÉ. POUR MAINTENIR LE DEGRÉ DE SÛRETÉ DE L'APPAREIL NE REMPLACER LES COMPOSANTS DONT LE FONCTIONNEMENT EST CRITIQUE POUR LA SÛRETÉ QUE PAR DES PIÈCES RECOMMANDÉES PAR LE FABRICANT

8) FUSE P.C BOARD (CEE, UK) NE-2319

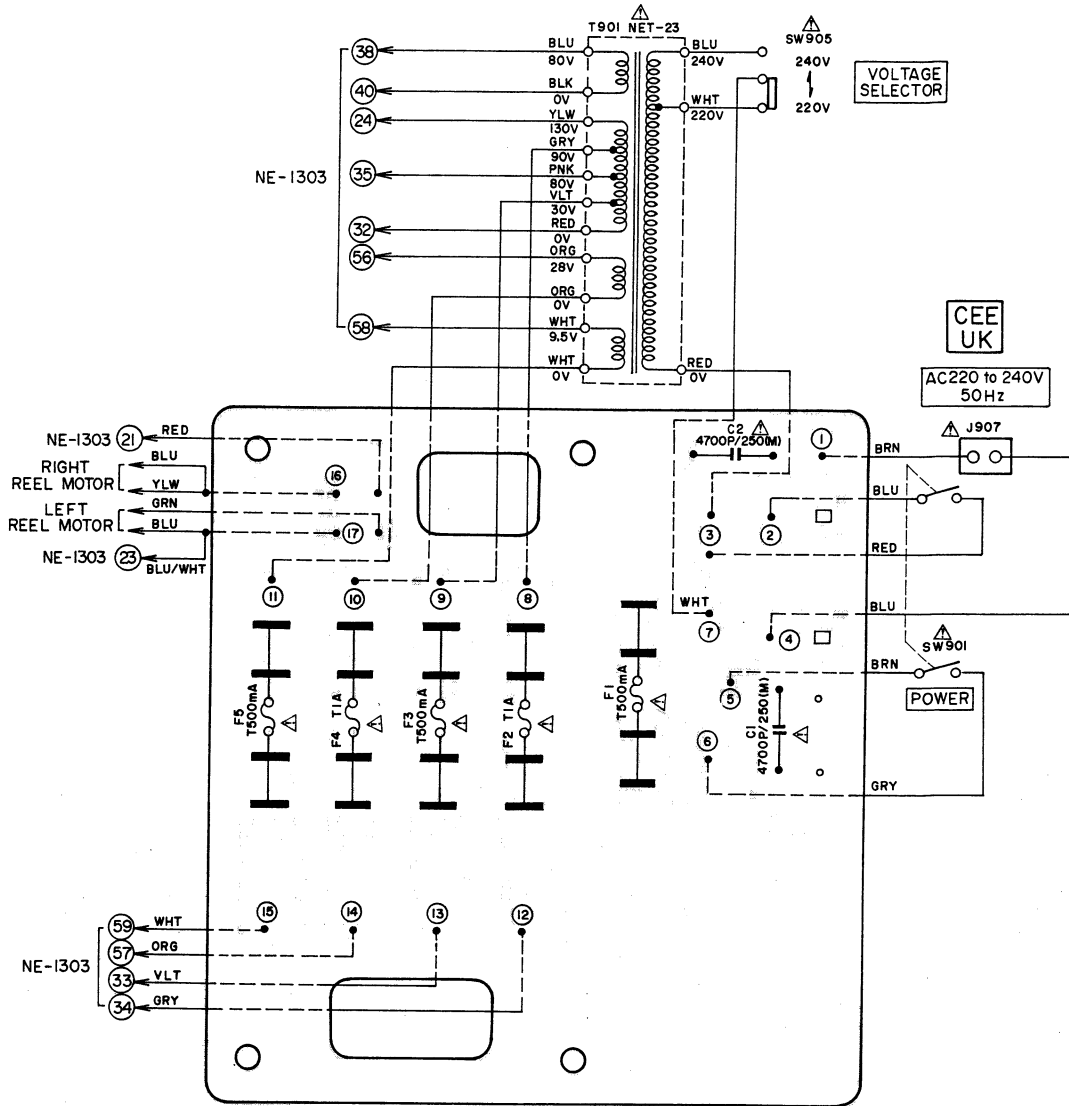

WARNING:  $\Delta$  INDICATES SAFETY CRITICAL COMPONENTS. FOR CONTINUED SAFETY, REPLACE SAFETY CRITICAL COMPONENTS ONLY WITH MANUFACTURER'S RECOMMENDED PARTS

AVERTISSEMENT:  $\Delta$  IL INDIQUE LES COMPOSANTS CRITIQUES DE SÛRETÉ. POUR MAINTENIR LE DEGRÉ DE SÛRETÉ DE L'APPAREIL, NE REMPLACER LES COMPOSANTS DONT LE FONCTIONNEMENT EST CRITIQUE POUR LA SÛRETÉ QUE PAR DES PIÈCES RECOMMANDÉES PAR LE FABRICANT

SECTION 2

**PARTS LIST**

TABLE OF CONTENTS

1. RECOMMENDED SPARE PARTS LIST .....	42
2. HEAD BLOCK .....	44
3. MAIN MOTOR BLOCK .....	46
4. REEL TABLE/BRAKE DRUM/REEL MOTOR BLOCK .....	47
5. OPERATION BLOCK .....	48
6. TENSION BLOCK .....	49
7. PINCH ROLLER PLUNGER BLOCK .....	50
8. POWER SUPPLY BLOCK .....	51
9. MECHA ASSEMBLY BLOCK .....	52
10. PRE AMP P.C BOARD (NE-5301) BLOCK .....	54
11. SYS. CON P.C BOARD (NE-1303) BLOCK .....	54
12. MIC AMP P.C BOARD (NE-5223) BLOCK .....	55
13. FUSE P.C BOARD (NE-2316) BLOCK .....	55
14. AMP ASSEMBLY BLOCK .....	56
15. FINAL ASSEMBLY BLOCK .....	58
INDEX .....	60

Resistor and Capacitor which is not listed in this parts list, please refer to COMMON LIST FOR SERVICE PARTS.

## HOW TO USE THIS PARTS LIST

1. This parts list is compiled by various individual blocks based on assembly process.
2. When ordering parts, please describe parts number, serial number, and model number in detail.
3. How to read List

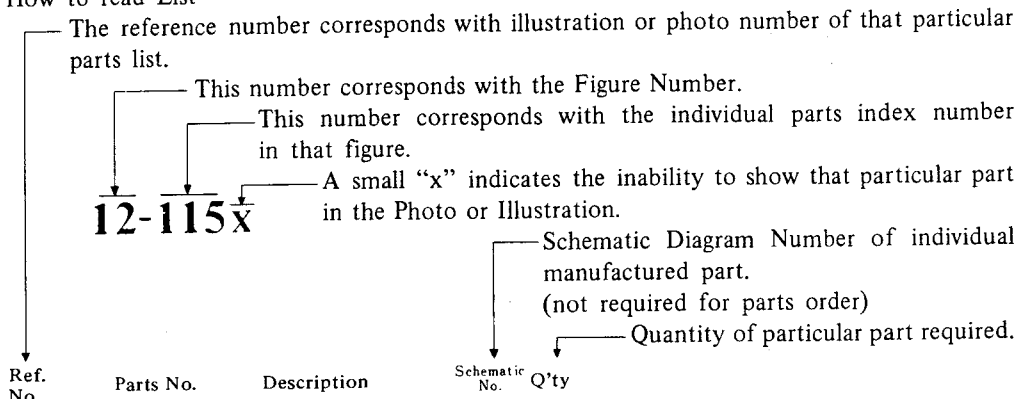

Ref. No.	Parts No.	Description	Schematic No.	Q'ty
<b>FLYWHEEL BLOCK #13</b>				
12-115x	800425	Flywheel Block Assy. Comp.	RDG #13	1
12-116	244506	Flywheel Only	RD-233	1
12-117x	244754	Felt, Flywheel	RD-275	1
12-118	251324	Main Metal Case	RD-236	1
12-119	253080	Main Metal	RD-237	1

4. The symbol numbers shown on the P.C. Board list can be matched with the Composite Views of Components of the Schematic Diagram or Service Manual.
5. Please utilize separate "Common List for Service Parts" for Resistor Parts orders.
6. The shape of the parts and parts name, etc. can be confirmed by comparing them with the parts shown on the Electrical Parts Table of P.C. Board.
7. Both the kind of part and installation position can be determined by the Parts Number. To determine where a parts number is listed, utilize Parts Index at end of Parts List.  
It is necessary first of all to find the Parts Number. This can be accomplished by using the Reference Number listed at right of parts number in the Parts Index. (meaning of ref. no. outlined in Item 3 above).
8. Utilize separate "Price List for Parts" to determine unit price. The most simple method of finding parts Price is to utilize the reference number.

- CAUTION:**
1. When placing an order for parts, be sure to list the parts no. model no., and description. There are instances in which if any of this information is omitted, parts cannot be shipped or the wrong parts will be delivered.
  2. Please be careful not to make a mistake in the parts no. If the parts no. is in error, a part different from the one ordered may be delivered.
  3. Because parts number and parts unit supply in the Preliminary Service Manual (Basic Parts List) may be partially changed, please use this parts list for all future reference.

**WARNING:** **⚠** INDICATES SAFETY CRITICAL COMPONENTS. FOR CONTINUED SAFETY, REPLACE SAFETY CRITICAL COMPONENTS ONLY WITH MANUFACTURER'S RECOMMENDED PARTS.

**AVERTISSEMENT:** **⚠** IL INDIQU LES COMPOSANTS CRITIQUES DE SURETE. POUR MAINTENIR LE DEGRE DE SECURITE DE L'APPAREIL NE REMPLACER LES COMPOSANTS DONT LE FONCTIONNEMENT EST CRITIQUE POUR LA SECURITE QUE PAR DES PIECES RECOMMANDEES PAR LE FABRICANT.

## AC INLET SYSTEM

This model is equipped with an AC INLET SYSTEM. Please refer to the AC INLET SYSTEM CHART below for the specific type. By the AC INLET SYSTEM, AC (mains) cord can be connected to and disconnected from the model because the model is provided with socket exclusively for AC (mains) cord on its main body. Please note, however, that certain models are not equipped with this system and has a built-in AC (mains) cord as before.

### AC INLET SYSTEM CHART

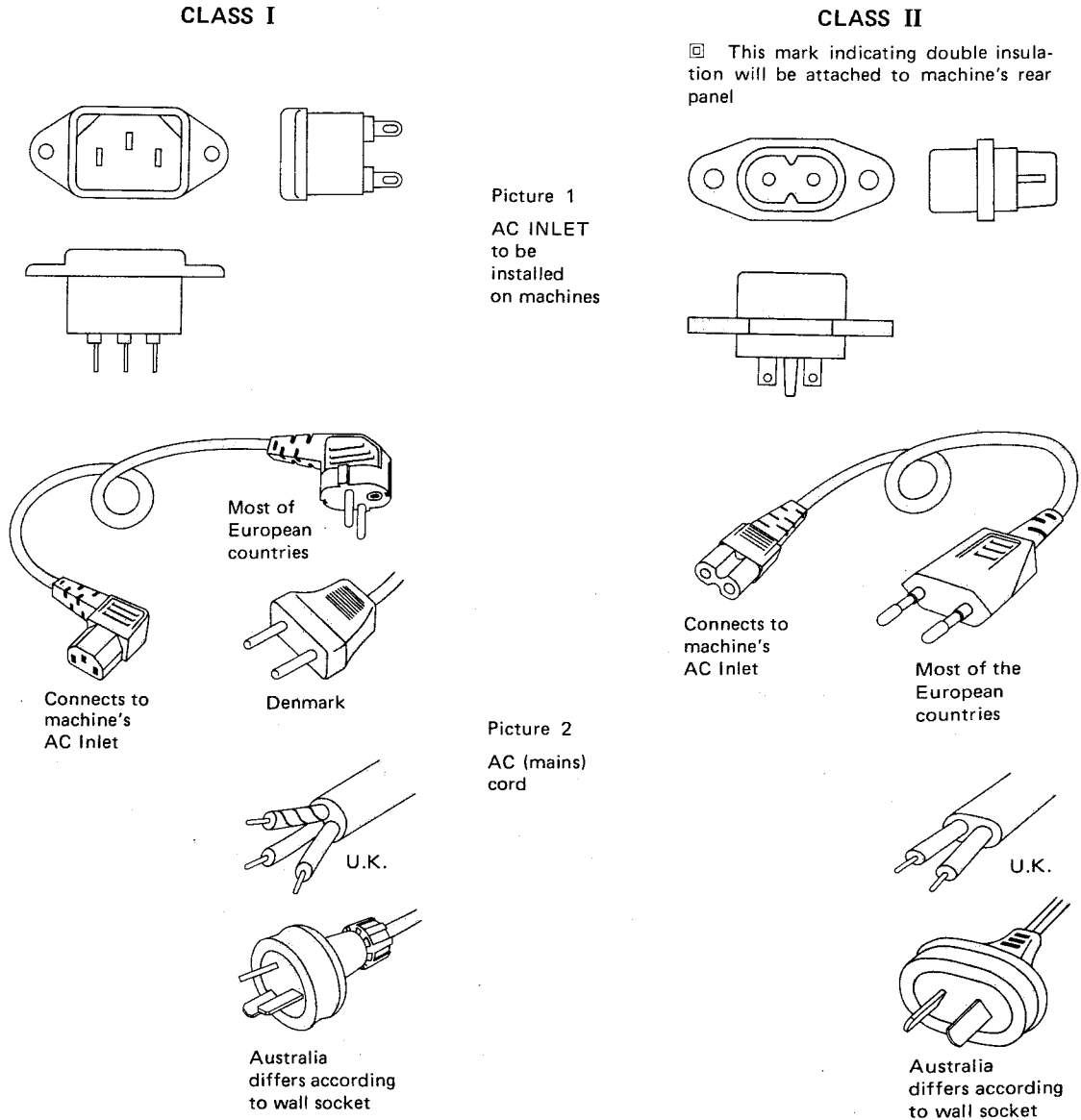

#### Parts List for AC (mains) Cord Set

Standard		Description	Type of AC Inlet	Parts No.
Class I	CEE	Cord Set CEE (3 cores)	3P	EW302993
	BEAB	Cord Set BEAB (3 cores)	3P	EW302994
	SAA	Cord Set SAA (3 cores)	3P	EW302996
	U/T	Cord Set U/T (3 cores)	3P	EW302646
Class II	CEE	Cord Set CEE (2 cores)	2P	EW638144
	BEAB	Cord Set BEAB (2 cores)	2P	EW302995
	SAA	Cord Set SAA (2 cores)	2P	EW302991
	U/T	Cord Set U/T (2 cores)	2P	EW302899

## 1. RECOMMENDED SPARE PARTS LIST

Because, if the parts listed below are on hand, almost any repair can be accomplished, we suggest that you stock these Recommended Spare Parts Items.

Parts No.	Description	Notes
BA301276	Mic Amp P.C Board Comp. GX-266D	
BA314230	Pre Amp P.C Comp. GX-266-2	
BA318550	Sys. Con. P.C Board Comp. GX-266-2 (JPN)	
BA318514	Sys. Con. P.C Board Comp. GX-266-2 (U/T)	
BH318520	Head Block Comp. GX-266-2	
BK301003	Operation Block Comp. GX-266D	
BL301288	Tension (L) Block Comp. GX-266D	
BL318498	Tension (R) Block Comp. GX-266-2	
BM314741	Motor Block Comp. 24XO-2 (Torque)	
BM308310	Motor Block Comp. (SCM-200) GX-635D	
BR482400	Supply Reel Table Block Comp. KH, ND, NE	
BT316510	△ Power Trans. NET-21	U/T
BT316511	△ Power Trans. NET-22	JPN
BT316512	△ Power Trans. NET-24	CSA
BT316513	△ Power Trans. NET-23	CEE, UK
BZ301009	Timer Block Comp. GX-266D	
ED219464	Germanium Diode 1N34A	
ED249377	LED GL-3AR1	
ED283138	LED GL-3PG1	
ED308945	Silicon Diode SVB10-100	
ED308941	Silicon Diode SVB10-200	
ED624903	Silicon Diode 1S2473	
ED560913	Silicon Diode 1S2473 VE	
ED224550	Silicon Diode 10D4	
ED309069	Zener Diode HZ6B-2	
ED510772	Zener Diode WZ-120	
ED303123	Zener Diode 05Z24U	
EF308847	△ Fuse 1.6A 125V	U/T, CSA
EF311839	△ Fuse 1.6A 250V	JPN
EF310229	△ Fuse 1A 125V	U/T, CSA
EF309387	△ Fuse 1A 250V	JPN
EF306954	△ Fuse 2A 125V	U/T, CSA
EF306950	△ Fuse 2A 250V	JPN
EF309391	△ Fuse 800MA 125V	U/T, CSA
EF309388	△ Fuse 800MA 250V	JPN
EF623103	△ Fuse (SEMKO T Type) 1AT	CEE, UK
EF593706	△ Fuse (SEMKO T Type) 500MAT	CEE, UK
EI430661	IC M53200P	IC2, 3
EI633960	IC M53202P	IC4
EI573840	IC M53204P	IC5

Parts No.	Description	Notes
EI308936	IC M54410P	IC1
EM315603	VU Meter KL-293C-5	BL
EM315919	VU Meter KL-293C-6	SILVER
EO383365	OSC. Coil OT-204	
EP315918	Plunger 1240PLTI	SL901
EP638706	Plunger Solenoid 1660PHT	SL903
EP249344	Reed Relay, L Type L24	RL1
EP308949	Relay BR211	RL3
EP309061	Relay FRL-264	RL1, 2, 4
EP303862	Sub Mini. Relay LCIN-JT DC24V	RL5, EXCE PT CSA
ES309059	△ Push SW. JP-27	SW901, U/T, JPN, CSA
ES310333	△ Push SW. JP-28	SW901, CEE, UK
ES301433	Lever SW. SLR542	SW2, 3
ES301433	Lever SW. SLR542	SW8
ES562465	Micro SW. K-1	SW908
ES316432	Micro SW. K-2 SEMKO	SW903, SW907
ES301434	Push SW. SUE-24	SW4
ES301438	Leaf SW. BSW-89	SW7
ES301207	Rotary SW. SRN1023SA1	SW902
ES301436	Slide SW. CL-206E	SW6
ES301435	Slide SW. CL-210E	SW1
ES258232	Slide SW. S-2930	U/T, JPN
ES301715	Slide SW. SSB02214	SW5
ET554657	Transistor 2SA733 (P) (Q)	
ET312497	Transistor 2SC1061 (B) (C) YC-40B	
ET603257	Transistor 2SC1312S (G) (H)	
ET308937	Transistor 2SC2130 (G) (H)	
ET391768	Transistor 2SC458BLG (C) (D)	
ET639437	Transistor 2SC945L (Q) (P)	
ET307349	Transistor 2SD794 (P) (Q)	
EV301428	Double-Axial 2-Throw/Vol. DM20R608 50KA×2	VR1, 2
EV301437	Single-Axial 2-Throw/Vol. GM70R-715 10KB×2	VR6
EV315928	Vol. VM10E 1K	
HE311139	Erase Head E4-201	
HP318522	PB Head P4-251	
HR308148	REC Head R4-241	
MB527556	Counter Belt D93×1.5	
MC315949	Counter Part GX-266-2	
ML301283	Tension Arm (R) Part GX-266D	
MP275984	Pinch Roller RD D=40	

## 2. HEAD BLOCK

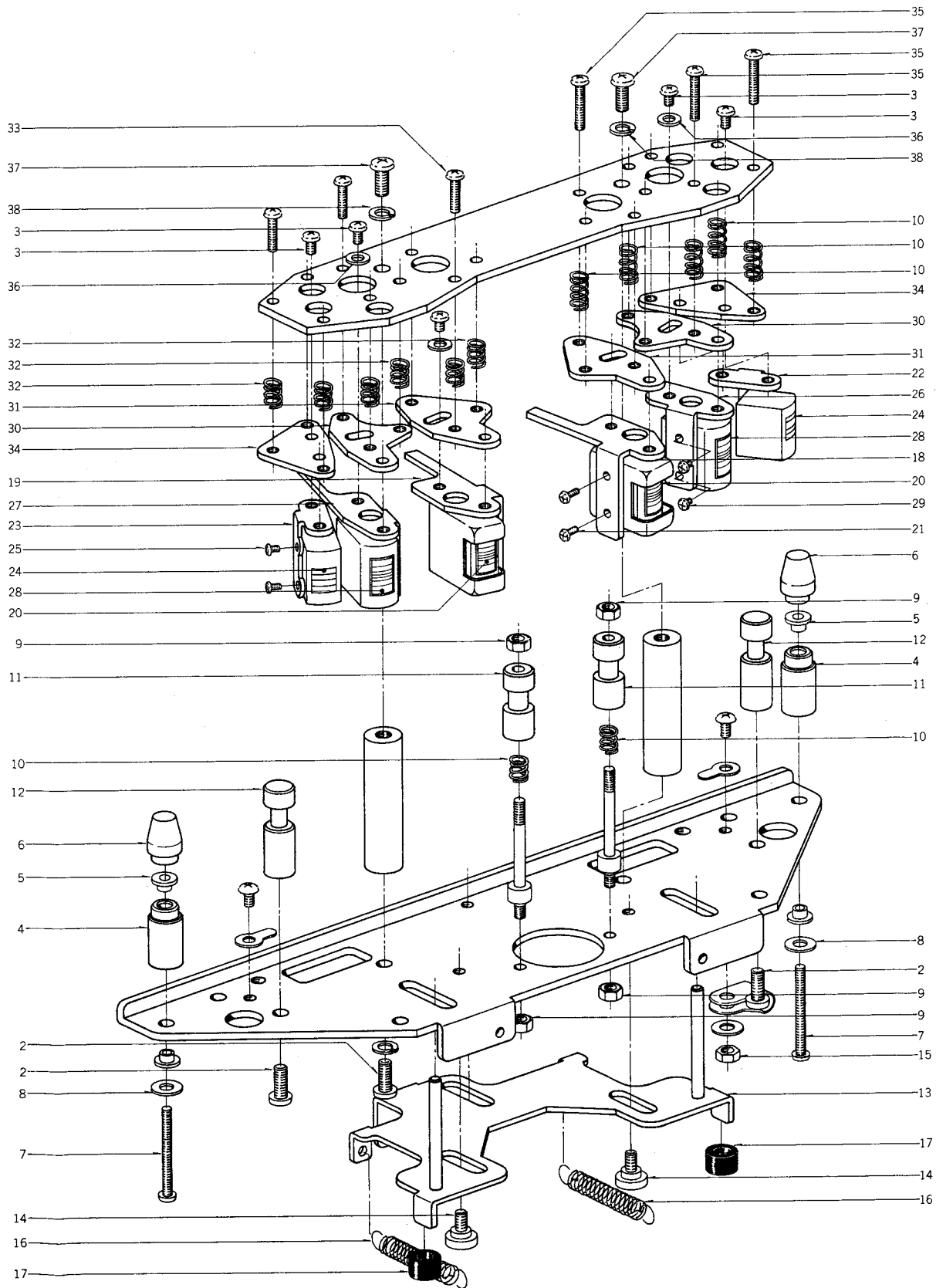



## 2. HEAD BLOCK

Ref. No.	Parts No.	Description	Schematic No.
2-1x	BH318520	Head Block Comp. GX-266-2	
2-2	ZS413201	Screw, Pan Head 4x8	
2-3	ZS608477	Screw, Pan Head 3x4 (Black)	
2-4	MS643050	Sensing Guide A	NE-0003
2-5	HZ527455	Sensing Spacer	ND-0011
2-6	MS643061	Sensing Guide B	NE-0004
2-7	ZS608264	Screw, Pan Head 3x25	
2-8	ZW259593	Washer (BSP) D3.4x7.8x0.5t	
2-9	ZW265522	Nut, #2 M3	
2-10	ZG466312	Angle Adjust Spring (E)	BS-0018
2-11	HZ301777	Tape Guide (C)	NE-0212
2-12	HZ528581	Tape Guide (A)	ND-0006
2-13	ML314216	Shifter Slide Part GX-266-2	NE-0301
2-14	ZS469710	MR Graduated Screw	MR-254
2-15	ZW273756	Nut, #1 M3	
2-16	ZG317114	Tension Lever Spring	MR-39
2-17	MB428343	Stopper Rubber, KD	KD-1088
2-18	HA301027	PB Head Angle (A)	NE-0202
2-19	HA301028	PB Head Angle (B)	NE-0202
2-20	HP318522	PB Head P4-251	
2-21	ZS608095	Screw, Pan Head 2x5	
2-22	HA301032	Erase Head Angle (A)	NE-0205
2-23	HA301033	Erase Head Angle (B)	NE-0205
2-24	HE311139	Erase Head E4-201	
2-25	ZS477876	Screw, Pan 2x3	
2-26	HA301029	REC Head Angle (A)	NE-0203
2-27	HA301030	REC Head Angle (B)	NE-0203
2-28	HR308148	REC Head R4-241	
2-29	ZS460440	Screw, Pan Head 2x4	
2-30	HB301025	REC Head Base	NE-0201
2-31	HB301365	PB Head Base	NE-0213
2-32	ZG206144	Angle Adjust Spring	RD-16
2-33	ZS417407	Screw, Pan Head 3x10 (Black)	
2-34	HZ301031	Erase Head Base	NE-0204
2-35	ZS608501	Screw, Pan Head 3x12 (Black)	
2-36	ZW301359	Washer D3x6x0.5t	
2-37	ZS201778	Screw, Pan Head 4x8 (Black)	
2-38	ZW668621	M4 Spring Washer (Black)	
2-39x	EJ304012	4P Micro Connector (1)	
		W-H8004-008	26-6-343
2-40x	EJ304013	4P Micro Connector (2)	
		W-H8004-007	26-6-344
2-41x	EJ321031	7P Connector (1)	26-6-358
2-42x	EJ321032	7P Connector (2)	26-6-359

### 3. MAIN MOTOR BLOCK

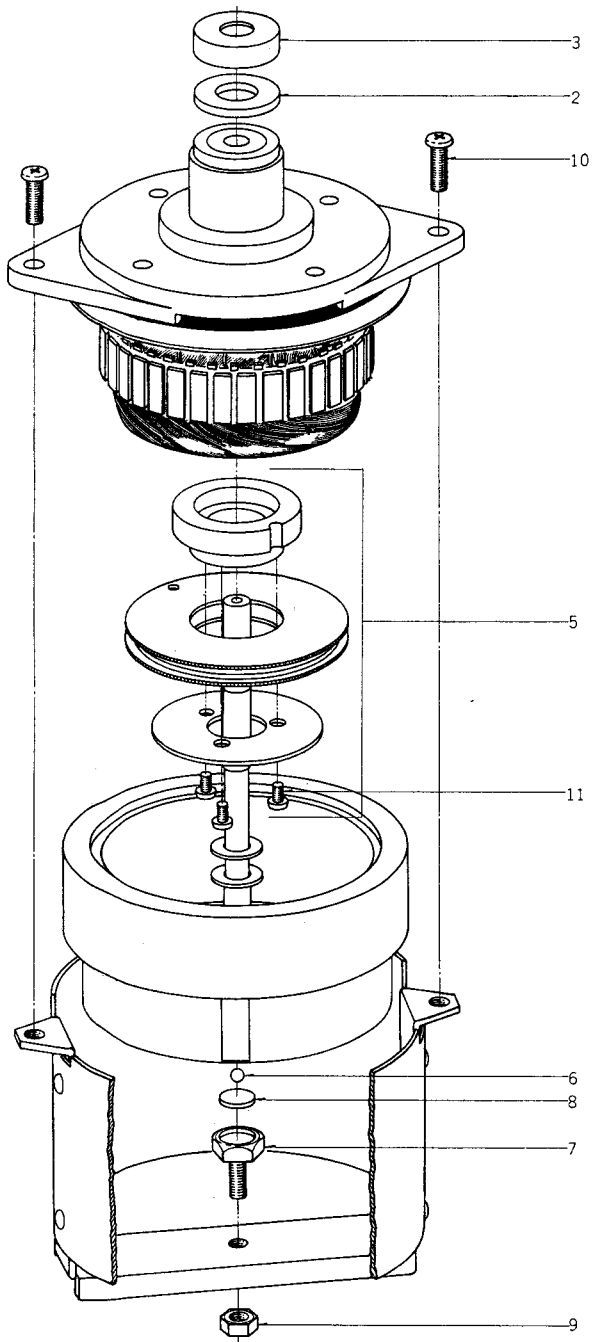

### 3. MAIN MOTOR BLOCK

Ref. No.	Parts No.	Description	Schematic No.
3-1x	BM308310	Motor Block Comp. (SCM-200) GX-635D	
3-2	ZW597622	Felt Washer	KJ-7022
3-3	SK597633	Cap	KJ-7023
3-4x	ZS608308	Screw, Pan 3x18 w/Washer	
3-5	BZ308315	Detection Gear Assy GX-635D	
3-6	MV368886	Steel Ball D3	
3-7	MZ585900	Shaft Support	LS-1203
3-8	MZ597690	Ball Holder	KJ-7029
3-9	ZW413278	Nut, #1 M5	
3-10	ZS413201	Screw, Pan Head 4x8	
3-11	ZS201508	Screw, Pan 2x4	

When ordering parts, please describe Parts Number, Description, and Model Number in detail.

#### 4. REEL TABLE/BRAKE DRUM/REEL MOTOR BLOCK

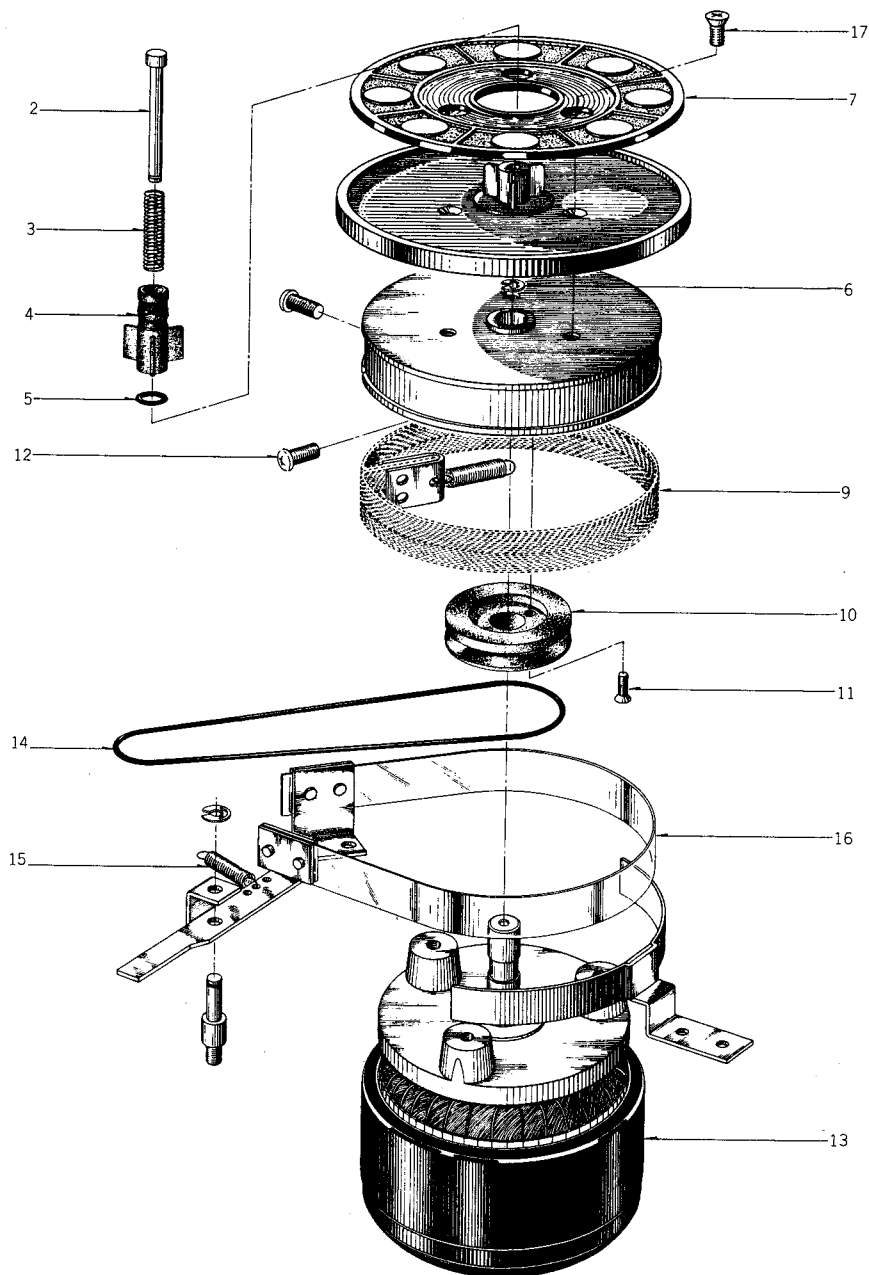

#### 4. REEL TABLE/BRAKE DRUM/REEL MOTOR BLOCK

Ref. No.	Parts No.	Description	Schematic No.	Ref. No.	Parts No.	Description	Schematic No.
<b>REEL TABLE BLOCK</b>				<b>REEL MOTOR BLOCK</b>			
4-1x	BR482400	Supply Reel Table Block Comp. KH, ND, NE		4-10	MR317507	Counter Pulley (Take-up)	MR-217
4-2	MS342000	Reel Shaft	3R-108	4-11	ZS433315	Screw, Countersunk Head 2.3x8	
4-3	ZG255633	Reel Spring	3R-109	4-12	ZS424056	Screw, Pan Head 4x10	
4-4	MT255420	Reel Retainer	3R-102	<b>REEL MOTOR BLOCK</b>			
4-5	MT516565	'O' Ring 2.8x1.9	3R-139	4-13	BM314741	Motor Block Comp. 24XO-2 (Torque)	
4-6	ZW270088	'E' Ring 1.9M	6-1-9	4-14	MB527556	Counter Belt D93x1.5	MD-1022
4-7	MT473422	Reel Table Rubber, KH	KH-2042	4-15	ZG315011	Brake Lever Spring	MR-116
<b>BRAKE DRUM BLOCK</b>				4-16	MT314987	Brake Band	MR-213
4-8x	ZS379350	Screw, Pan 3x6		4-17	ZS403222	Screw, Countersunk Head 3x10	
4-9	MT436860	Brake Cloth Comp.	MR-269				

When ordering parts, please describe Parts Number, Description, and Model Number in detail.

## 5. OPERATION BLOCK

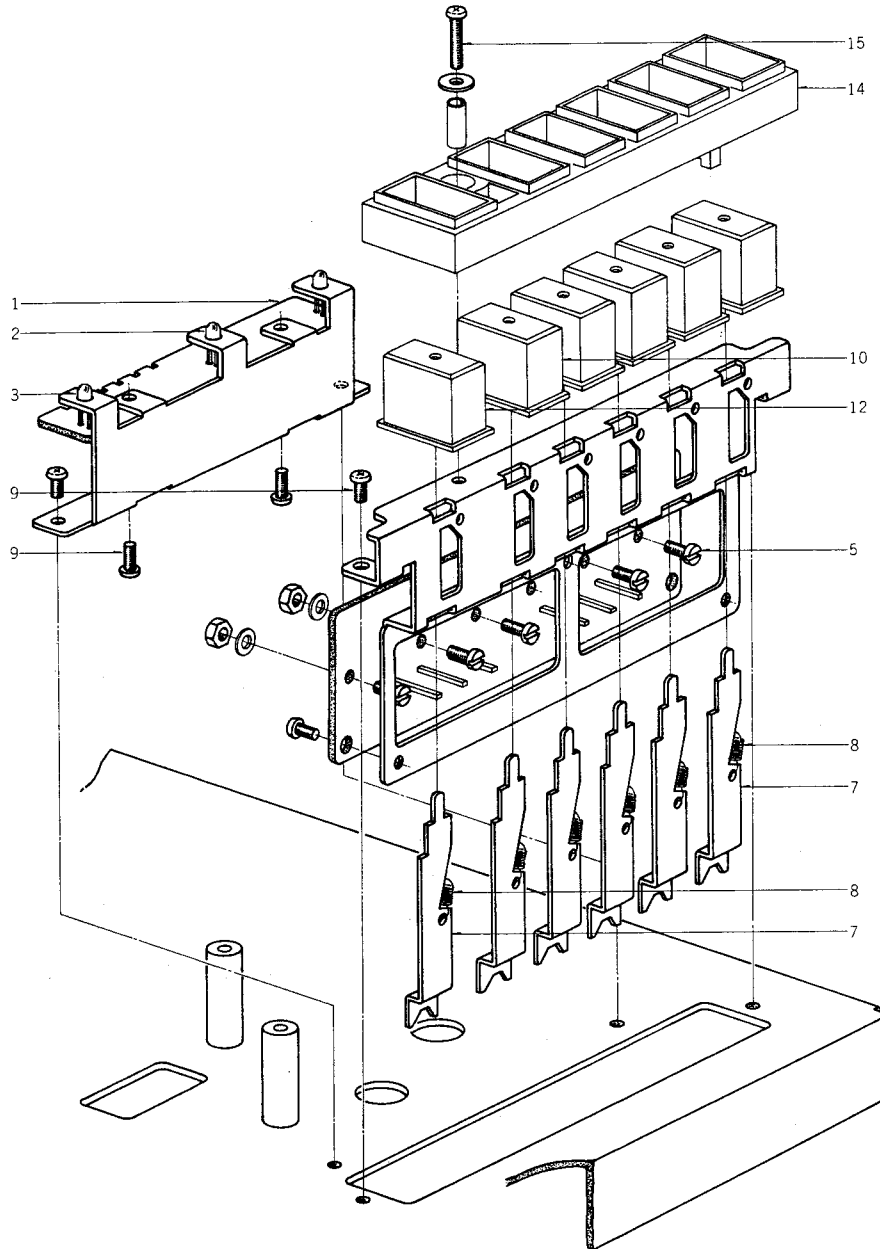

## 5. OPERATION BLOCK

Ref. No.	Parts No.	Description	Schematic No.	Ref. No.	Parts No.	Description	Schematic No.
<b>DETECTION P.C BOARD BLOCK</b>							
5-1	EA301281	Lamp P.C Board	NE-2229	5-7	ML301056	Operation Lever	NE-2214
5-2	ED283138	LED GL-3PG1	45-15-15	5-8	ZG456120	Setting Lever Spring	CS-1187
5-3	ED249377	LED GL-3AR1	45-15-14	5-9	ZS422076	Screw, Pan 3x5	
5-4x	ZS325495	Tapping Screw, #2 BR 3x6		5-10	SK315850	Operate Knob (C)	NE-2220
<b>OPERATION P.C BOARD BLOCK</b>				5-11x	SK315881	Operate Knob (C-BL)	NE-2220
5-5	ZS302720	Screw, Flat Head 3x6 (Black)		5-12	SK315851	Operate Knob (D)	NE-2220
<b>OPERATION BLOCK</b>				5-13x	SK315882	Operate Knob (D-BL)	NE-2220
5-6x	BK301003	Operation Block Comp. GX-266D	NE-2240	5-14	SE301121	Button Escutcheon	NE-2224
				5-15	ZS483502	Screw, Pan Head 3x13	

When ordering parts, please describe Parts Number, Description, and Model Number in detail.

## 6. TENSION BLOCK

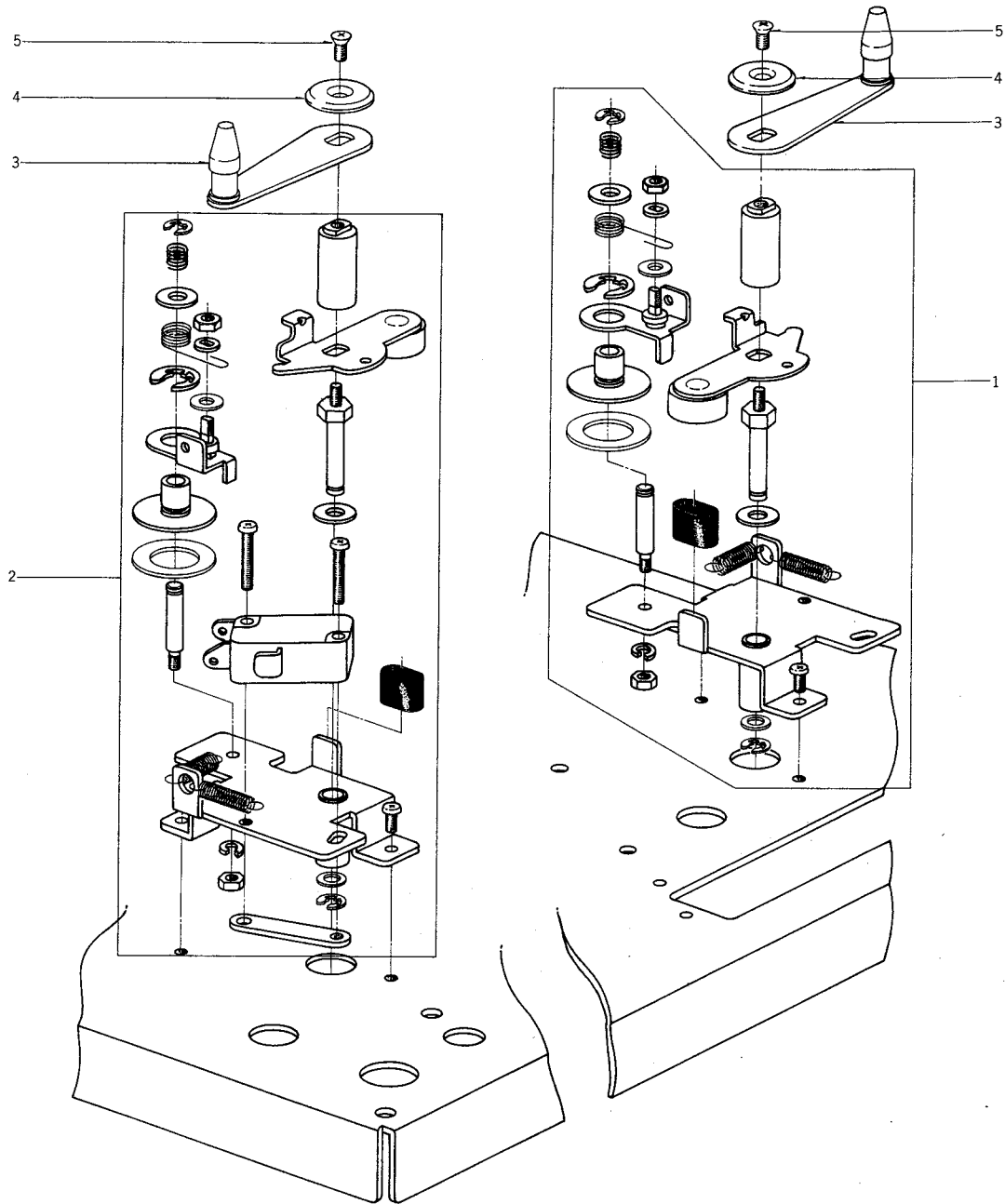

## 6. TENSION BLOCK

Ref. No.	Parts No.	Description	Schematic No.
6-1	BL301287	Tension (R) Block Comp. GX-266D	
6-2	BL301288	Tension (L) Block Comp. GX-266D	
6-3	ML314193	Tension Arm (B) Part GX-266-2	NE2226
6-4	ZW302052	Decorative Washer	NE1212
6-5	ZS411660	Screw, Oval Countersunk Head 3x6	

When ordering parts, please describe Parts Number, Description, and Model Number in detail.

## 7. PINCH ROLLER PLUNGER BLOCK

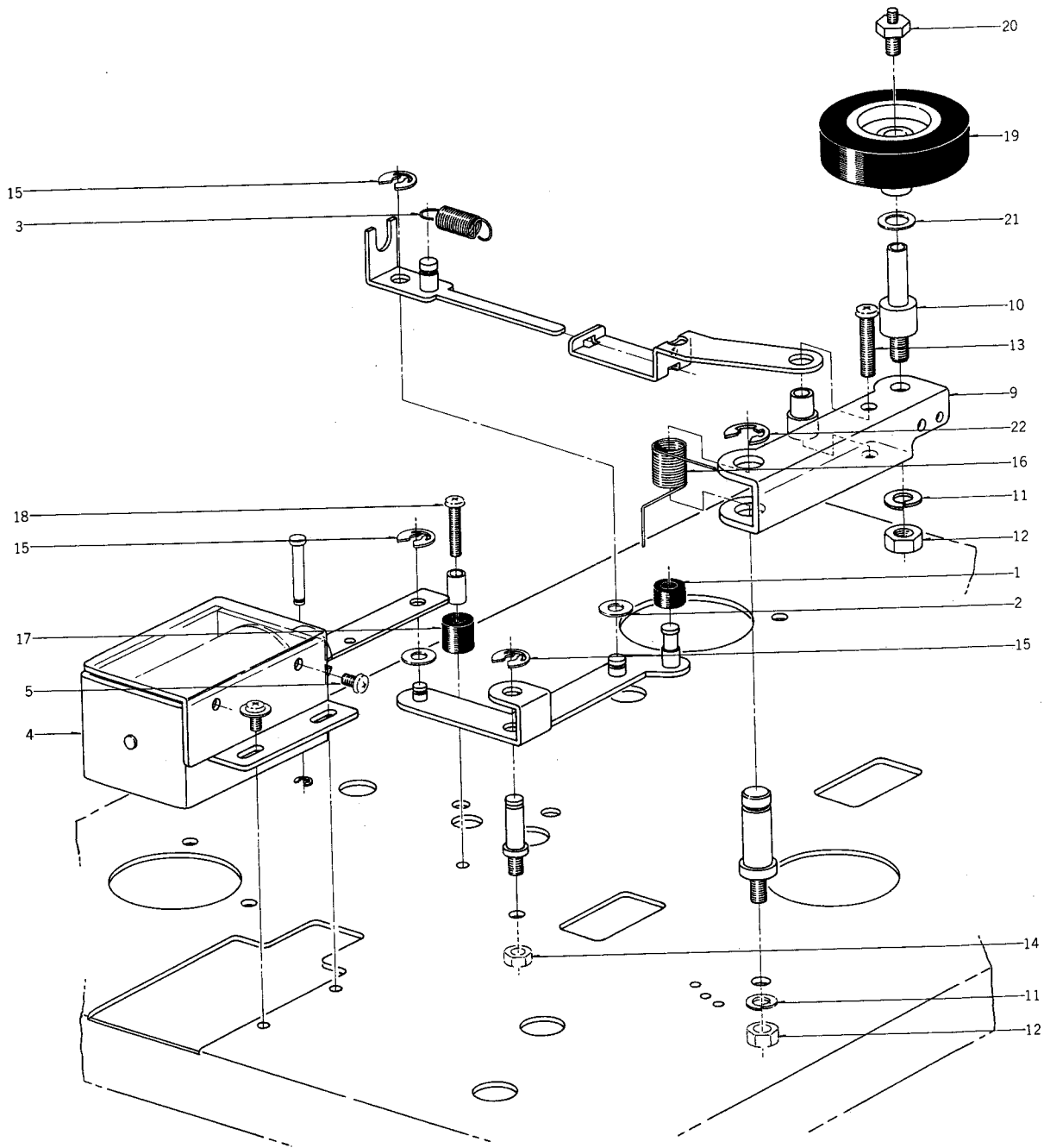

## 7. PINCH ROLLER PLUNGER BLOCK

Ref. No.	Parts No.	Description	Schematic No.
7-1	MB428343	Stopper Rubber, KD	KD-1088
7-2	ZW260076	Washer (Nylon) D6.1x10x0.5t	
7-3	ZG321345	P Spring	NE-2320
7-4	EP638706	Plunger Solenoid 1660PHT	44-1-74
7-5	ZS422076	Screw, Pan 3x5	
7-6x	ZW270088	'E' Ring 1.9M	6-1-9
7-9	ML528445	P Lever	ND-1036
7-10	MS527591	Pinch Roller Shaft	ND-1030
7-11	ZW274026	Spring Washer, M5	
7-12	ZW413278	Nut, #1 M5	

Ref. No.	Parts No.	Description	Schematic No.
7-13	ZS444262	Screw, Binding Head 4x18	
7-14	ZW413188	Nut, #1 M4	
7-15	ZW290283	'U' Ring 2.85M	6-1-1
7-16	ZG301340	Pinch Roller Spring	NE-2237
7-17	MZ610457	Pause Lever Cushion	LE-1005
7-18	ZS422965	Screw, Pan Head 3x15	
7-19	MP275984	Pinch Roller RD D=40	RD-231

When ordering parts, please describe Parts Number, Description, and Model Number in detail.

## 8. POWER SUPPLY BLOCK

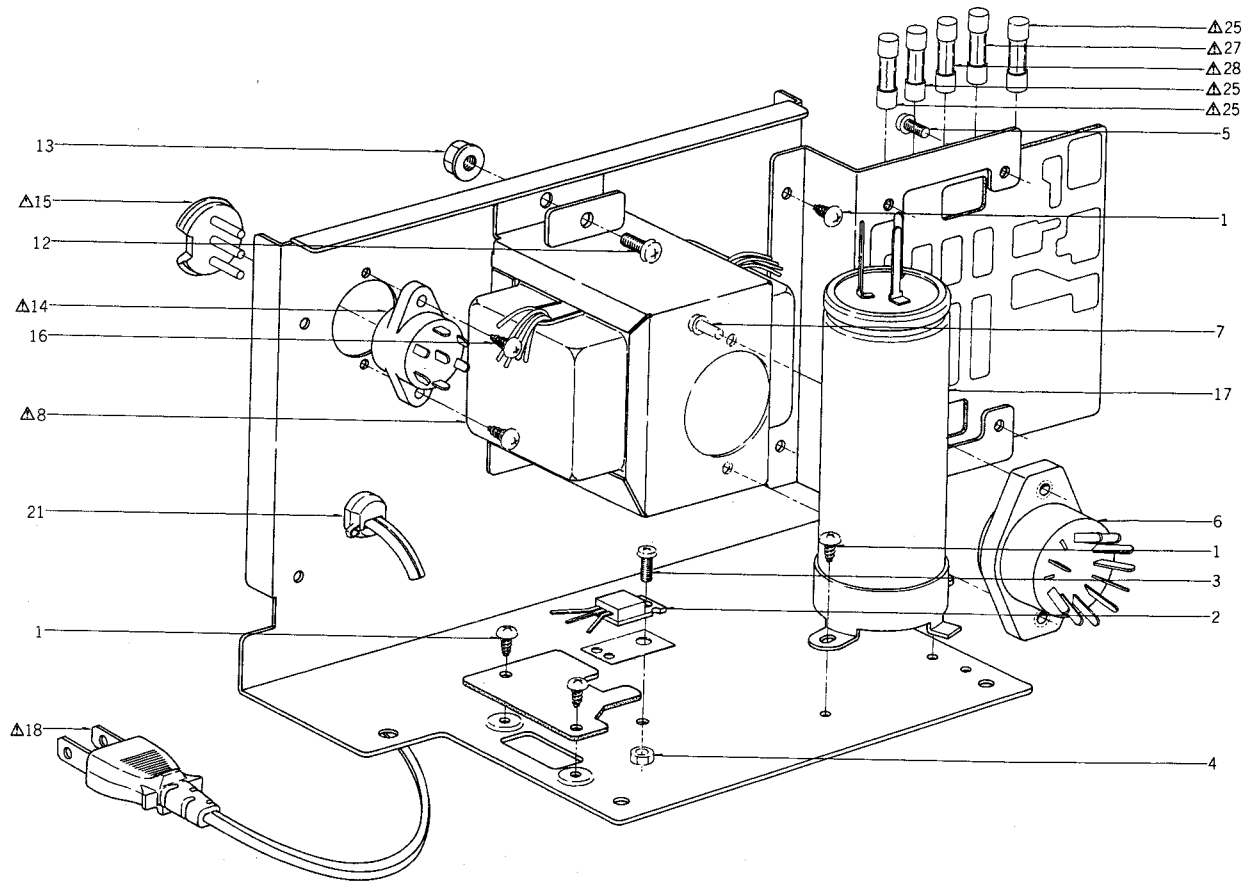

## 8. POWER SUPPLY BLOCK

Ref. No.	Parts No.	Description	Schematic No.	Ref. No.	Parts No.	Description	Schematic No.
8-1	ZS325495	Tapping Screw, #2 BR 3x6		8-22x	EJ301513	△ 2P Inlet (CEE, UK)	31-1-200
8-2	ET321036	Transistor 2SC2336B(P)(Q)(R)	45-1-333	8-23x	ES306430	△ Slide SW. J-S4013#01 (CEE, UK)	25-3-142
8-3	ZS421806	Screw, Pan 3x8		8-24x	ZS422076	Screw, Pan 3x5	
8-4	ZW516993	Nut, #1 M3		8-25	EF310229	△ Fuse 1A 125V (U/T)	39-1-65
8-5	ZS379350	Screw, Pan 3x6		8-26x	EF306954	△ Fuse 2A 125V (U/T)	39-1-65
8-6	EJ307274	9P Remo. Con Socket	31-1-223	8-27	EF308847	△ Fuse 1.6A 125V (U/T)	39-1-65
8-7	ZS421740	Screw, Pan Head 3x8 (Black)		8-28	EF309391	△ Fuse 800mA 125V (U/T)	39-1-65
8-8	BT316510	△ Power Trans. NET-21 (U/T)	38-4-754	8-29x	EF306950	△ Fuse 2A 250V (JPN)	39-1-64
8-9x	BT316511	△ Power Trans. NET-22 (JPN)	38-4-755	8-30x	EF311839	△ Fuse 1.6A 250V (JPN)	39-1-64
8-10x	BT316512	△ Power Trans. NET-24 (CSA)	38-4-756	8-31x	EF309388	△ Fuse 800mA 250V. (JPN)	39-1-64
8-11x	BT316513	△ Power Trans. NET-23 (CEE, UK)	38-4-757	8-32x	EF309387	△ Fuse 1A 250V (JPN)	39-1-64
8-12	ZS424056	Screw, Pan Head 4x10		8-33x	EF306954	△ Fuse 2A 125V (CSA)	39-1-65
8-13	ZW413267	Flange Nut M4		8-34x	EF308847	△ Fuse 1.6A 125V (CSA)	39-1-65
8-14	EJ262732	△ Socket (Volt. Selector)	31-1-190	8-35x	EF309391	△ Fuse 800mA 125V (CSA)	39-1-65
8-15	EJ249467	△ Voltage Selector	42-1-109	8-36x	EF310229	△ Fuse 1A 125V (CSA)	39-1-65
8-16	ZS447840	Tapping Screw, #2 BR 3x8		8-37x	EF593706	△ Fuse (SEMKO T Type) 500MAT (CEE, UK)	39-1-53
8-17	EC249592	MP/C. 4+4μF 250WV	24-9-116	8-38x	EF623103	△ Fuse (SEMKO T Type) 1AT (CEE, UK)	39-1-53
8-18	EW306428	△ AC Cord (U/T)	26-3-64				
8-19x	EW306427	△ AC Cord (JPN)	26-3-63				
8-20	EW305691	△ AC Cord CUL (CSA)	26-3-65				
8-21	EZ631945	Strain Relief SR-4N-4 (U/T, JPN, CSA)	2-7-49				

When ordering parts, please describe Parts Number, Description, and Model Number in detail.

# 9. MECHA ASSEMBLY BLOCK

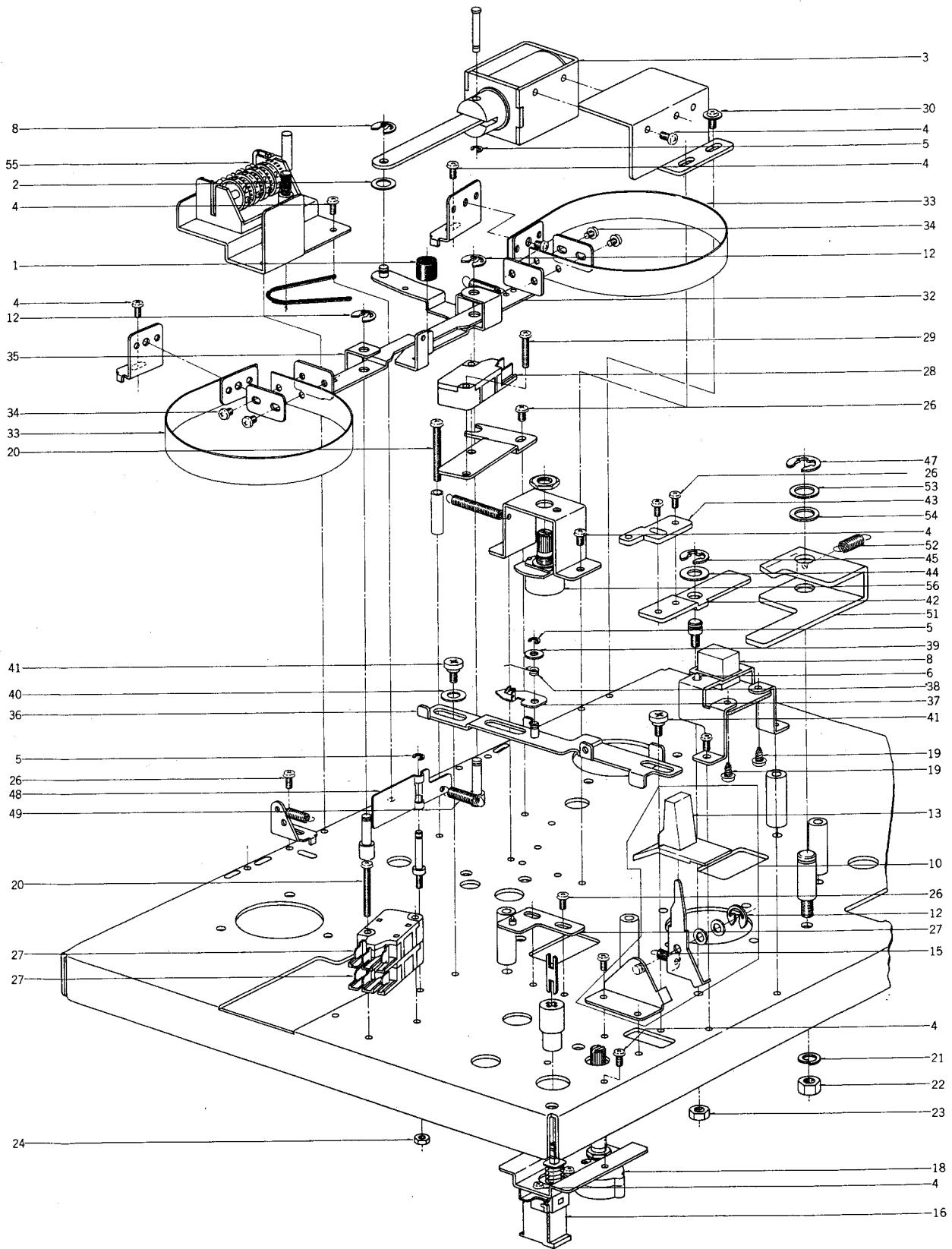



## 9. MECHA ASSEMBLY BLOCK

Ref. No.	Parts No.	Description	Schematic No.
<b>BRAKE PLUNGER BLOCK</b>			
9-1	MB606712	Stopper Rubber KJ	KJ-2060
9-2	ZW260043	Washer (Nylon) D6.1x10x0.2t	
9-3	EP315918	Plunger 1240PLTI	44-1-120
9-4	ZS422076	Screw, Pan 3x5	
9-5	ZW270088	'E' Ring 1.9M	6-1-9
<b>MUTE P.C BOARD BLOCK</b>			
9-6	ED249377	LED GL-3AR1	45-15-14
9-7x	ES301205	Tentacle SW. SCM81002	25-9-4
9-8	SB315805	Button (A)	NE-2301
9-9x	SB315806	Button (A-BL)	NE-2301
<b>PAUSE SW. BLOCK</b>			
9-10	BS318495	Pause SW. Block Comp. GX-266-2	NE-1072
9-11x	BS318496	Pause SW. Block Comp. GX-266-2-BL	NE-1072
9-12	ZW290283	'U' Ring 2.85M	6-1-1
9-13	SK315807	Lever Knob (A)	NE-2302
9-14x	SK315808	Lever Knob (A-BL)	NE-2302
9-15	ZG313025	Coil Spring T1-5.0/0.32-14.0	
<b>POWER SW. BASE BLOCK</b>			
9-16	ES309059	Δ Push SW. JP-27 (U/T, JPN, CSA)	25-5-285
9-17x	ES310333	Δ Push SW. JP-28 (CEE, UK)	25-5-308
9-18	ES301207	Rotary SW. SRN1023SA1	25-6-110
9-19	ZS325495	Tapping Screw, #2 BR 3x6	
<b>MECHA ASSEMBLY BLOCK</b>			
9-20	ZS608264	Screw, Pan Head 3x25	
9-21	ZW274026	Spring Washer, M5	
9-22	ZW413278	Nut, #1 M5	
9-23	ZW413188	Nut, #1 M4	
9-24	ZW273756	Nut, #1 M3	
9-25x	ZS447840	Tapping Screw, #2 BR 3x8	
9-26	ZS323728	Screw, Binding Head 3x5	
9-27	MZ673165	Pause Lock Base Part	NE-1010
9-28	ES562465	Micro SW. K-1	25-1-26
9-29	ZS419670	Screw, Pan 3x12	
9-30	ZS608321	Screw, Pan Head 3x6, W=8	
9-31x	ZW420682	Washer (Nylon) D4.2x9x0.5t	
9-32	ML314976	Brake Lever A	MR-210
9-33	MT314987	Brake Band	MR-213
9-34	ZS432674	Screw, Pan Head 3x3	
9-35	ML396810	Brake Lever (B)	KD-1038
9-36	ML301274	Pause Arm (3) Part NE-2	NE-1204
9-37	TC515575	SW. Lock Cam (B)	CG-2301
9-38	ZG514440	Button Lock Spring (B)	CG-2303
9-39	ZW616004	Washer D3.1x8x1t	
9-40	ZW313593	Washer (PBP) D5.1x10.3x0.5t	
9-41	ZS469710	MR Graduated Screw	MR-254
9-42	ML301038	Pause Arm (1)	NE-1202
9-43	ML301039	Pause Arm (2)	NE-1203
9-44	ZW260188	Washer (Nylon) D6.2x13x0.5t	
9-45	ZW270134	'E' Ring 5M	6-1-9
9-46x	ZW420682	Washer (Nylon) D4.2x9x0.5t	
9-47	ZW334653	'E' Ring 7M	6-1-9
9-48	MZ640080	Quick Plate	NE-1039
9-49	ZG232121	Tension Lever Spring	MH-143
9-50x	ZS608310	Screw, Pan 3x5, w/Lug	
9-51	ML301103	Pause Arm (B-2)	NE-1012
9-52	ZG516418	Eject Spring	CG-1238
9-53	ZW393851	Washer (Nylon) D8.1x13x0.8t	
9-54	ZW575763	Washer (SPC) D8.1x13x0.5t	
9-55	MC315949	Counter Part GX-266-2	9-1-78
9-56	EV315928	Vol. VM10E 1K	36-6-38

When ordering parts, please describe Parts Number, Description, and Model Number in detail.

## 10. PRE AMP P.C BOARD (NE-5301) BLOCK

Symbol No.	Parts No.	Description	Schematic No.
10-1	BA314230	Pre Amp P.C Comp. GX-266-2	NE-5301
10-TR1to5	ET639437	Transistor 2SC945L(Q)(P)	45-1-85
10-TR6,7	ET603257	Transistor 2SC1312S(G)(H)	45-1-182
10-TR8	ET639437	Transistor 2SC945L(Q)(P)	45-1-85
10-TR9to11	ET391768	Transistor 2SC458LG(C)(D)	45-1-29
10-TR12	ET603257	Transistor 2SC1312S(G)(H)	45-1-182
10-TR13to15	ET639437	Transistor 2SC945L(Q)(P)	45-1-85
10-TR16	ET554657	Transistor 2SA733(P)(Q)	45-1-124
10-TR17	ET603257	Transistor 2SC1312S(G)(H)	45-1-182
10-D2	ED219464	Germanium Diode 1N34A	45-3-1
10-D3	ED560913	Silicon Diode 1S2473 VE	45-3-23
10-D4	ED624903	Silicon Diode 1S2473	45-3-28
10-D5	ED219464	Germanium Diode 1N34A	45-3-1
10-D6	ED624903	Silicon Diode 1S2473	45-3-28
10-RL1	EP249344	Reed Relay, L Type L24	47-2-28
10-VL1,2	EO301448	Inductor 45H-044 1MH	23-1-277
10-L4	EO301467	Ferri Inductor RX-9P 3.3MH (J)	23-1-275
10-L6,7	EO565558	Ferri Inductor FL9H 240μH (J)	23-1-213
10-L8	EO624857	Inductor GE6070A 23MH	23-1-227
10-L9	EO301712	Inductor RX-9P 22MH(J)	23-1-275
10-J1	EJ315926	Mic Jack GX-266-2	31-2-112
10-J2	EJ308985	Din, 4P Pin Jack (Except JPN)	31-5-144
10-J2	EJ308986	4P Pin Jack (JPN)	31-5-145
10-J5	EJ315927	Mic Jack GX-266-2	31-2-112
10-VR1	EV464207	Semi-fixed/Vol. V8K4-1 5 kB	36-10-266
10-VR2,3	EV520806	Semi-fixed/Vol. V8K4-1 10 kB	36-10-266
10-VR4,5	EV464220	Semi-fixed/Vol. V8K4-1 50 kB	36-10-266
10-VR6	EV301437	Single Axial 2 Throw Vol. GM70R-715 10 kBx2	36-22-28
10-VR7	EV478686	Semi-fixed/Vol. V8K4-1 1 kB	36-10-266
10-SW1	ES301435	Slide SW. CL-210E	25-3-136
10-SW2,3	ES301433	Lever SW. SLR542	25-12-39
10-SW4	ES301434	Push SW. SUE-24	25-5-256
10-SW5	ES301715	Slide SW. SSB02214	25-3-127
10-SW6	ES301436	Slide SW. CL-206E	25-3-135
10-SW7	ES301438	Leaf SW. BSW-89	25-10-27
10-SW8	ES301433	Lever SW. SLR542	25-12-39
10-T1	EO383365	OSC. Coil OT-204	23-4-20
10-TC1,2	EC558202	Trimmer/C. TM-80A 80PF	24-2-26
10-P1,3	EJ249366	Micro Connector 7P Plug W-P0507	42-1-104
10-P2,4	EJ249333	Micro Connector 4P Plug W-P0504	42-1-104
10-R17	ER651532	Carbon/R. F 1/2W 100 ohms (J)	35-11-13
10-R32	ER310844	Metal Oxide Film/R. (Homing Type 3W 150 ohms (J)	35-11-23
10-R52	ER666854	Carbon/R. F 1/2W 220 ohms (J)	35-11-13
10-R71	ER666854	Carbon/R. F 1/2W 220 ohms (J)	35-11-13
10-C2	EC604102	Solid Aluminum/C. (Vert. Type) 0.33μF(K) 25WV	24-19-2
10-C10	EC303145	Tantalum/C. (DTS Type) 22μF(K) 16WV	24-15-8
10-C18	EC562678	Styrol/C. (Vert. Type) 750PF(J) 50WV	24-11-3
10-C22	EC558235	Styrol/C. (Tub. Type) 1800PF(J) 250WV	24-11-10

Symbol No.	Parts No.	Description	Schematic No.
10-C23	EC675178	Solid Aluminum/C. (Vert. Type) 0.47μF(K) 25WV	24-19-2
10-C25	EC310435	Solid Aluminum/C. (Vert. Type) 3.3μF(K) 16WV	24-19-2
10-C26	EC303145	Tantalum/C. (DTS Type) 22μF(K) 16WV	24-15-8
10-C27	EC250672	Elect./C. (Vert. Type) 47μF 16WV NL	24-20-4
10-C28	EC432810	Elect./C. (Vert. Type) 10μF 16WV NL	24-20-4
10-C30	EC405898	Styrol/C. (Vert. Type) 470PF(J) 50WV	24-11-3
10-C34	EC434070	Styrol/C. (Vert. Type) 680PF(J) 50WV	24-11-3
10-C35	EC405898	Styrol/C. (Vert. Type) 470PF(J) 50WV	24-11-3
10-C36	EC675178	Solid Aluminum/C. (Vert. Type) 0.47μF(K) 25WV	24-19-2
10-C37	EC432810	Elect./C. (Vert. Type) 10μF 16WV NL	24-20-4
10-C39	EC513944	Styrol/C. (Vert. Type) 100PF(J) 50WV	24-11-3
10-C41	EC513944	Styrol/C. (Vert. Type) 100PF(J) 50WV	24-11-3
10-C44	EC269515	Styrol/C. (Vert. Type) 120PF(J) 50WV	24-11-3

## 11. SYS. CON P.C BOARD (NE-1303) BLOCK

Symbol No.	Parts No.	Description	Schematic No.
11-1	BA318514	Sys. Con. P.C Board Comp. GX-266-2 (U/T)	NE-1303
11-2	BA318550	Sys. Con. P.C Board Comp. GX-266-2 (JPN)	NE-1303
11-3	BA318515	Sys. Con. P.C Board Comp. GX-266-2 (CSA)	NE-1303
11-4	BA318516	Sys. Con. P.C Board Comp. GX-266-2 (CEE, UK)	NE-1303
11-IC1	EI308936	IC M54410P	45-8-304
11-IC2,3	EI430661	IC M53200P	45-8-38
11-IC4	EI633960	IC M53202P	45-8-140
11-IC5	EI573840	IC M53204P	45-8-106
11-TR1	ET312497	Transistor 2SC1061(B)(C) YC-40B	45-1-96
11-TR2	ET639437	Transistor 2SC945L(Q)(P)	45-1-85
11-TR3	ET307349	Transistor 2SD794(P)(Q)	45-1-334
11-TR4to8	ET639437	Transistor 2SC945L(Q)(P)	45-1-85
11-TR9,10	ET554657	Transistor 2SA733(P)(Q)	45-1-124
11-TR11	ET639437	Transistor 2SC945L(Q)(P)	45-1-85
11-TR12	ET554657	Transistor 2SA733(P)(Q)	45-1-124
11-TR13,14	ET639437	Transistor 2SC945L(Q)(P)	45-1-85
11-TR15to20	ET308937	Transistor 2SC2130(G)(H)	45-1-317
11-TR21	ET554657	Transistor 2SA733(P)(Q)	45-1-124
11-TR22to30	ET639437	Transistor 2SC945L(Q)(P)	45-1-85
11-TR31	ET554657	Transistor 2SA733(P)(Q)	45-1-124
11-TR32	ET639437	Transistor 2SC945L(Q)(P)	45-1-85
11-D1	ED308945	Silicon Diode SVB10-100	45-2-82
11-D2	ED303123	Zener Diode 05Z24U	45-6-76
11-D3	ED308945	Silicon Diode SVB10-100	45-2-82
11-D4	ED309069	Zener Diode HZ6B-2	45-6-80
11-D5to8	ED510772	Zener Diode WZ-120	45-6-67
11-D9	ED308941	Silicon Diode SVB10-200	45-2-82
11-D10	ED308952	Germanium Diode 1K34A-LR	45-3-47

When ordering parts, please describe Parts Number, Description, and Model Number in detail.

Symbol No.	Parts No.	Description	Schematic No.
11-D11to13	ED308953	Germanium Diode 1K34A-LH	45-3-46
11-D14	ED308952	Germanium Diode 1K34A-LR	45-3-47
11-D15to24	ED560913	Silicon Diode 1S2473 VE	45-3-23
11-D25	ED308952	Germanium Diode 1K34A-LR	45-3-47
11-D26to28	ED560913	Silicon Diode 1S2473 VE	45-3-23
11-D29	ED624903	Silicon Diode 1S2473	45-3-28
11-D30	ED560913	Silicon Diode 1S2473 VE	45-3-23
11-D31	ED308953	Germanium Diode 1K34A-LH	45-3-46
11-D32	ED624903	Silicon Diode 1S2473	45-3-28
11-D33,34	ED308953	Germanium Diode 1K34A-LH	45-3-46
11-D35to38	ED560913	Silicon Diode 1S2473 VE	45-3-23
11-D39	ED308953	Germanium Diode 1K34A-LH	45-3-46
11-D40,41	ED308952	Germanium Diode 1K34A-LR	45-3-47
11-D42to44	ED560913	Silicon Diode 1S2473 VE	45-3-23
11-D45,46	ED308952	Germanium Diode 1K34A-LR	45-3-47
11-D47to50	ED560913	Silicon Diode 1S2473 VE	45-3-23
11-D51	ED308952	Germanium Diode 1K34A-LR	45-3-47
11-D52	ED308941	Silicon Diode SVB10-200	45-2-82
11-D53to56	ED224550	Silicon Diode 10D4	45-2-16
11-RL1,2	EP309061	Relay FRL-264	47-1-37
11-RL3	EP308949	Relay BR211	47-2-31
11-RL4	EP309061	Relay FRL-264	47-1-37
11-RL5	EP303862	Sub Mini. Relay LCIN-JT DC24V (Except CSA)	47-1-35
11-RL5	EP315936	Relay LC1-C-US-D244 (CSA)	47-1-40
11-SW1	ES258232	Slide SW. S-2930 (U/T, JPN)	25-3-129
11-VR1	EV302718	Semi-fixed/Vol. V18K3-6 (4US) 50 kB	36-9-26
11-VR2	EV309071	Semi-fixed/Vol. V18K3-6 (4US) 20 kB	36-9-26
11-CR1to13	ER300820	Spark Quencher CRU-112 0.1 $\mu$ +120 ohm 125WV (JPN, U/T, CSA)	41-1-63
11-R105	ER308956	Cement/R. 20W 220 ohms (K)	35-16-81
11-R106	ER315937	Cement/R. 20W 10 ohms (K)	35-16-81
11-C1	EC565345	Elect./C. (Vert. Type) 1000 $\mu$ F 50WV	24-12-9
11-C5	EC459145	Elect./C. (Vert. Type) 2200 $\mu$ F 16WV	24-12-9
11-C20	EC310369	Metalized Film/C. (Vert. Type) 1.5 $\mu$ F(K) 180WV	24-16-15
11-C21	EC310368	Metalized Film/C. (Vert. Type) 3.5 $\mu$ F (K) 180WV	24-16-13
11-C28	EC310374	Tantalum/C. (D Type) 100 $\mu$ F(M) 3.15WV	24-15-12
11-C37	EC304708	Tantalum/C. (D Type) 47 $\mu$ F(M) 6.3WV	24-15-12
11-C40,41	EC304708	Tantalum/C. (D Type) 47 $\mu$ F(M) 6.3WV	24-15-12
11-C42,43	EC304186	NP/C. (Vert. Type) 10 $\mu$ F(M) 16WV	24-17-26
11-C48,49	EC308950	Tantalum/C. 10 $\mu$ F(M) 6.3WV	24-15-12
11-C55to77	EC310372	Metalized Film/C. (Vert. Type) 0.1 $\mu$ F(M) 220WV	24-16-14
11-5	ZS421806	Screw, Pan 3x8	

## 12. MIC AMP P.C BOARD (NE-5223) BLOCK

Symbol No.	Parts No.	Description	Schematic No.
12-1	BA301276	Mic Amp P.C Board Comp. GX-266D	NE-2250A B
12-TR1to3	ET391768	Transistor 2SC458LG(C)(D)	45-1-29
12-TR4	ET603257	Transistor 2SC1312S(G)(H)	45-1-182
12-J1to3	MH243742	Pin. 163740-1 (3P) 163740-1	52-1-34
12-VR1,2	EV301428	Double-Axial 2-Throw/Vol. DM20R608 50kA $\times$ 2	36-18-4
12-2	ZS558101	Screw, Pan 3x6 w/Washer	
12-R14	ER666854	Carbon/R. F 1/2W 220 ohms (J)	35-11-13
12-C2	EC432810	Elect./C. (Vert. Type) 10 $\mu$ F 16WV NL	24-20-4
12-C3	EC476965	Elect./C. (Vert. Type) 47 $\mu$ F 2.5WV NL	24-20-4
12-C4	EC301431	Styrol/C. (w/Rubber) 220PF(K) 50WV	24-11-13
12-C6	EC301432	Solid Aluminum/C. (Vert. Type) 2.2 $\mu$ F(K) 16WV	24-19-2
12-C13	EC432810	Elect./C. (Vert. Type) 10 $\mu$ F 16WV NL	24-20-4

## 13. FUSE P.C BOARD (NE-2316) BLOCK

Symbol No.	Parts No.	Description	Schematic No.
13-C1	EC551160	$\Delta$ Ceramic/C. DB821 NA 0.01 $\mu$ F(Z) 1.4KWV (U/T, JPN)	24-5-55
13-C1	EC314688	$\Delta$ Ceramic/C. DE7150 FZ 0.01 $\mu$ F(P) 125WV (CSA)	24-5-87
13-C1,2	EC301320	$\Delta$ MP/C. 4700PF(M) 250WV (CEE, UK)	24-9-122

When ordering parts, please describe Parts Number, Description, and Model Number in detail.

# 14. AMP ASSEMBLY BLOCK

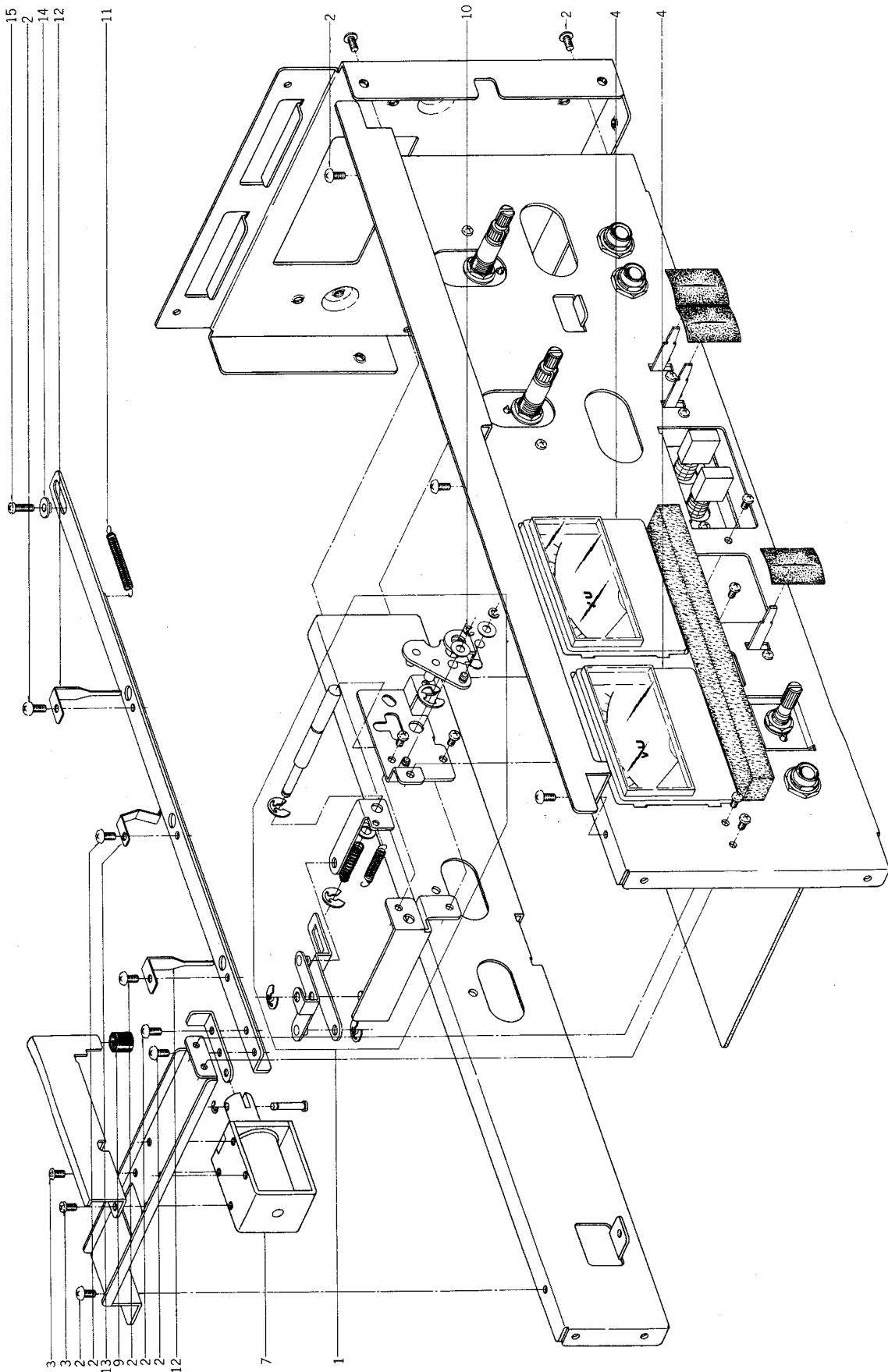

---

## 14. AMP ASSEMBLY BLOCK

Ref. No.	Parts No.	Description	Schematic No.
<b>TIMER BLOCK</b>			
14-1	BZ301009	Timer Block Comp. GX-266D	NE-2243
<b>AMP ASSEMBLY BLOCK</b>			
14-2	ZS325495	Tapping Screw, #2 BR 3x6	
14-3	ZS422076	Screw, Pan 3x5	
14-4	EM315919	VU Meter KL-293C-6	46-1-231
14-5x	EM315603	VU Meter KL-293C-5 (BL)	46-1-230
14-6x	ZW263946	Nylon Rivet 4x5	2-7-57
14-7	EP315918	Plunger 1240PLTI	44-1-120
14-8	ZS422076	Screw, Pan 3x5	
14-9	MB606712	Stopper Rubber KJ	KJ-2060
14-10	ZW270088	'E' Ring 1.9M	6-1-9
14-11	ZS325495	Tapping Screw, #2 BR 3x6	
14-12	ZG301072	Reverse SW. Spring (A)	NE-5206
14-13	ZG301073	Reverse SW. Spring (B)	NE-5207
14-14	ZW625241	Graduated Washer	MY-1013
14-15	ZS447840	Tapping Screw, #2 BR 3x8	
14-16x	ZS558101	Screw, Pan 3x6 w/Washer	

## 15. FINAL ASSEMBLY BLOCK

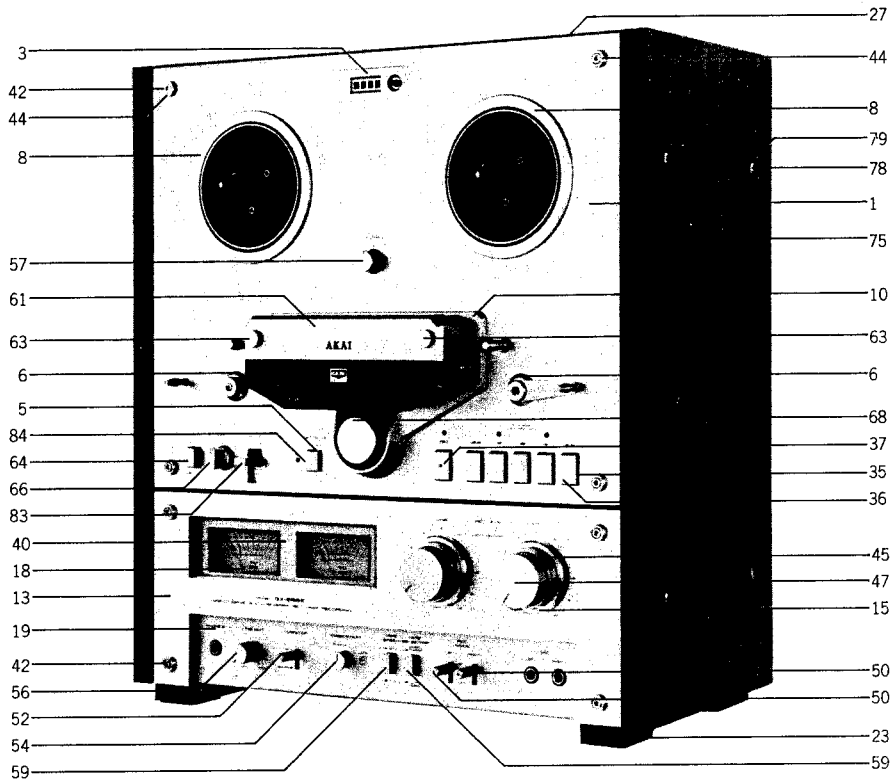

## 15. FINAL ASSEMBLY BLOCK

Ref. No.	Parts No.	Description	Schematic No.	Ref. No.	Parts No.	Description	Schematic No.
<b>MECHA PANEL BLOCK</b>				<b>FINAL ASSEMBLY BLOCK</b>			
15-1	BD314189	Mecha Panel Block Comp. GX-266-2	NE-6325	15-16x	SZ315827	Memory Rng (BL)	NE-6303
15-2x	BD314190	Mecha Panel Block Comp. GX-266-2-BL	NE-6325	15-17x	SZ301132	Ring Retainer	NE-6223
15-3	SE315912	Counter Escatcheon (B)	MY-6006	15-18	SE301115	Meter Cover	NE-6206
15-4x	SE315913	Counter Escatcheon (B-BL)	MY-6006	15-19	SP315914	Operation Panel	NE-6323
15-5	SE315833	Button Escatcheon	NE-6306	15-20x	SP315915	Operation Panel (BL)	NE-6323
15-6	SZ315899	Decoration Ring (B)	NE-6219	15-21x	SP315892	Bottom Plate (B)	NE-6202
15-7x	SZ315900	Decoration Ring (B-BL)	NE-6219	15-22x	SP301232	Bottom Plate (BL)	NE-6202
15-8	SE315931	Reel Table Escatcheon (2-C)	TD-6021	15-23	SA301411	Square Foot Part GX-215D	2-6-15
15-9x	SE315577	Reel Table Escutcheon (2-D) (BL)	TD-6021	15-24x	ZS413234	Screw, Pan Head 4x12	
15-10	SC315845	Head Cover Base	NE-6312	15-25x	ZS315923	Screw, Truss 4x8	
15-11x	SC315846	Head Cover Base (BL)	NE-6312	15-26x	ZS201341	Screw, Truss Head 4x8 (Black)	NE-6201
15-12x	ZS462194	Tapping Screw, #2 Pan 3x8 (W=8)		15-27	SP315891	Upper Cover (C)	NE-6201
<b>AMP PANEL BLOCK</b>				15-28x	SP301231	Upper Cover (BL)	
15-13	BD314186	Amp Panel Block Comp. GX-266-2	NE-6324	15-29x	ZS315923	Screw, Truss 4x8	
15-14x	BD314187	Amp Panel Block Comp. GX-266-2-BL	NE-6324	15-30x	ZS201341	Screw, Truss Head 4x8 (Black)	NE-6203
15-15	SZ315826	Memory Ring	NE-6303	15-31x	SP315893	Side Cover (B)	NE-6203
				15-32x	SP301255	Side Cover (BL)	
				15-33x	ZS315923	Screw, Truss 4x8	
				15-34x	ZS201341	Screw, Truss Head 4x8 (Black) (BL)	
				15-35	SE301121	Button Escutcheon	NE-2224
				15-36	SK315850	Operate Knob (C)	NE-2220

When ordering parts, please describe Parts Number, Description, and Model Number in detail.

Ref. No.	Parts No.	Description	Schematic No.
15-37	SK315851	Operate Knob (D)	NE-2220
15-38x	SK315881	Operate Knob (C-BL)	NE-2220
15-39x	SK315882	Operate Knob (D-BL)	NE-2220
15-40	SE315836	Meter Frame	NE-6308
15-41x	SE315837	Meter Frame (BL)	NE-6308
15-42	ZS691277	Panel Screw	CI-6019
15-43x	ZS322939	Panel Screw (B) (BL)	CI-6019
15-44	ZW315917	Decoration Washer	TG-6020
15-45	SK315824	Knob (Lower)	NE-6302
15-46x	SK315825	Knob (Lower-BL)	NE-6302
15-47	SK315822	Knob (Upper)	NE-6301
15-48x	SK315823	Knob (Upper-BL)	NE-6301
15-49x	SE301778	SW. Mask	NE-6244
15-50	SK315886	Lever Knob (C)	NE-6214
15-51x	SK315889	Lever Knob (-BL)	NE-6214
15-52	SK315888	Lever Knob (D)	NE-6214
15-53x	SK315890	Lever Knob (D-BL)	NE-6214
15-54	SK315884	Timer Knob (B)	NE-5217
15-55x	SK315885	Timer Knob (B-BL)	NE-5217
15-56	SK315703	Knob (A)	CF-6223
15-57	SK315932	Knob (C)	CM-6308
15-58x	SK315933	Knob (C-BL)	CM-6308
15-59	SB315834	Button (C)	NE-6307
15-60x	SB315835	Button (C-BL)	NE-6307
15-61	HB320470	Head Cover Assy GX-266-2	
15-62x	HB320471	Head Cover (BL) Assy GX-266-2-BL	
15-63	ZS315844	Cover Screw	NE-6311
15-64	SB315828	Button (B)	NE-6304
15-65x	SB315829	Button (B-BL)	NE-6304
15-66	SK315830	Knob (A)	NE-6305
15-67x	SK315831	Knob (A-BL)	NE-6305
15-68	SK314364	Pinch Roller Cap (C) Part GX-266-2	ND-6028
15-69x	SK314365	Pinch Roller Cap (C-BL) Part GX-266-2-BL	ND-6028
15-70x	SP315839	Back Board GX-266-2 (U/T)	NE-6309,6316
15-71x	SP315838	Back Board GX-266-2 (JPN)	NE-6309,6315
15-72x	SP315840	Back Board GX-266-2 (CSA, AAL)	NE-6309,6317
15-73x	SP315841	Back Board GX-266-2 (CEE, UK)	NE-6309,6318
15-74x	ZS297641	Tapping Screw #2, 3x8 (Bind) W=10	
15-75	SP305597	Side Board (Except JPN)	NE-6249
15-76x	SP315907	Side Plate (B) (JPN)	NE-6249
15-77x	SP315908	Side Plate (B-BL)	NE-6249
15-78	ZS520525	Screw, Binding Head 4x25 (Black) (Except JPN)	
15-79	ZW548010	Spot Facing Washer (Except JPN)	MU-6028
15-80x	ZS315930	Screw, Bind 4x25 (JPN)	
15-81x	ZW315929	Spot Facing Washer (B) (JPN)	MU-6028
15-82x	EW315767	AC Cord Set CEE 2 Cores	26-3-72
15-83	SK315807	Lever Knob (A)	NE-2302
15-84	SB315805	Button (A)	NE-2301

# INDEX

Parts No.	Ref. No. & Symbol No.	Parts No.	Ref. No. & Symbol No.	Parts No.	Ref. No. & Symbol No.	Parts No.	Ref. No. & Symbol No.
BA301276	12-1	ED308953	11-D11to13	ES301435	10-SW1	MP275984	7-19
BA314230	10-1	ED308953	11-D31	ES301436	10-SW6	MR317507	4-10
BA318514	11-1	ED308953	11-D33,34	ES301438	10-SW7	MS342000	4-2
BA318515	11-3	ED308953	11-D39	ES301715	10-SW5	MSS27591	7-10
BA318516	11-4	ED309069	11-D4	ES306430	8-23x	MS643050	2-4
BA318550	11-2	ED510772	11-D5to8	ES309059	9-16	MS643061	2-6
BD314186	15-13	ED560913	10-D3	ES310333	9-17x	MT255420	4-4
BD314187	15-14x	ED560913	11-D15to24	ES562465	9-28	MT314987	4-16
BD314189	15-1	ED560913	11-D26to28	ET307349	11-TR3	MT314987	9-33
BD314190	15-2x	ED560913	11-D30	ET308937	11-TR15to20	MT436860	4-9
BH318520	2-1x	ED560913	11-D35to38	ET312497	11-TR1	MT473422	4-7
BK301003	5-6x	ED560913	11-D42to44	ET321036	8-2	MT516565	4-5
BL301287	6-1	ED560913	11-D47to50	ET391768	10-TR9to11	MV368886	3-6
BL301288	6-2	ED624903	10-D4	ET391768	12-TR1to3	MZ585900	3-7
BM308310	3-1x	ED624903	10-D6	ET554657	10-TR16	MZ597690	3-8
BM314741	4-13	ED624903	11-D29	ET554657	11-TR9,10	MZ610457	7-17
BR482400	4-1x	ED624903	11-D32	ET554657	11-TR12	MZ640080	9-48
BS318495	9-10	EF306950	8-29x	ET554657	11-TR21	MZ673165	9-27
BS318496	9-11x	EF306954	8-26x	ET554657	11-TR31	SA301411	15-23
BT316510	8-8	EF306954	8-33x	ET603257	10-TR6,7	SB315805	9-8
BT316511	8-9x	EF308847	8-27	ET603257	10-TR12	SB315806	15-84
BT316512	8-10x	EF308847	8-34x	ET603257	10-TR17	SB315828	9-9x
BT316513	8-11x	EF309387	8-32x	ET603257	12-TR4	SB315829	15-64
BZ301009	14-1	EF309388	8-31x	ET639437	10-TR1to5	SB315829	15-65x
BZ308315	3-5	EF309391	8-28	ET639437	10-TR8	SB315834	15-59
EA301281	5-1	EF309391	8-35x	ET639437	10-TR13to15	SB315835	15-60x
EC249592	8-17	EF310229	8-25	ET639437	11-TR2	SC315845	15-10
EC250672	10-C27	EF310229	8-36x	ET639437	11-TR4to8	SC315846	15-11x
EC269515	10-C44	EF311839	8-30x	ET639437	11-TR11	SE301115	15-18
EC301320	13-C1,2	EF593706	8-37x	ET639437	11-TR13,14	SE301121	5-14
EC301431	12-C4	EF623103	8-38x	ET639437	11-TR22to30	SE301121	15-35
EC301432	12-C6	EI308936	11-IC1	ET639437	11-TR32	SE301778	15-49x
EC303145	10-C10	EI430661	11-IC2,3	EV301428	12-VR1,2	SE315577	15-9x
EC303145	10-C26	EI573840	11-IC5	EV301437	10-VR6	SE315833	15-5
EC304186	11-C42,43	EI633960	11-IC4	EV302718	11-VR1	SE315836	15-40
EC304708	11-C37	EJ249333	10-P2,4	EV309071	11-VR2	SE315837	15-41x
EC304708	11-C40,41	EJ249366	10-P1,2	EV315928	9-56	SE315912	15-3
EC308950	11-C48,49	EJ249467	8-15	EV464207	10-VR1	SE315913	15-4x
EC310368	11-C21	EJ262732	8-14	EV464220	10-VR4,5	SE315931	15-8
EC310369	11-C20	EJ301513	8-22x	EV478686	10-VR7	SK314364	15-68
EC310372	11-C55to77	EJ304012	2-39x	EV520806	10-VR2,3	SK314365	15-69x
EC310374	11-C28	EJ304013	2-40x	EW305691	8-20	SK315703	15-56
EC310435	10-C25	EJ307274	8-6	EW306427	8-19x	SK315807	9-13
EC314688	13-C1	EJ308985	10-J2	EW306428	8-18	SK315807	15-83
EC405898	10-C30	EJ308986	10-J2	EW315767	15-82x	SK315808	9-14x
EC405898	10-C35	EJ315926	10-J1	EZ631945	8-21	SK315822	15-47
EC432810	10-C28	EJ315927	10-J5	HA301027	2-18	SK315823	15-48x
EC432810	10-C37	EJ321031	2-41x	HA301028	2-19	SK315824	15-45
EC432810	12-C2	EJ321032	2-42x	HA301029	2-26	SK315825	15-46x
EC432810	12-C13	EM315603	14-5x	HA301030	2-27	SK315830	15-66
EC434070	10-C34	EM315919	14-4	HA301032	2-22	SK315831	15-67x
EC459145	11-C5	EO301448	10-VL1,2	HA301033	2-23	SK315850	5-10
EC476965	12-C3	EO301467	10-L4	HB301025	2-30	SK315850	15-36
EC513944	10-C39	EO301712	10-L9	HB301365	2-31	SK315851	5-12
EC513944	10-C41	EO383365	10-T1	HB320470	15-61	SK315851	15-37
EC551160	13-C1	EO565558	10-L6,7	HB320471	15-62x	SK315881	5-11x
EC558202	10-TC1,2	EO624857	10-L8	HE311139	2-24	SK315881	15-38x
EC558235	10-C22	EP249344	10-RL1	HP318522	2-20	SK315882	5-13x
EC562678	10-C18	EP303862	11-RL5	HR308148	2-28	SK315882	15-39x
EC565345	11-C1	EP308949	11-RL3	HZ301031	2-34	SK315884	15-54
EC604102	10-C2	EP309061	11-RL1,2	HZ301777	2-11	SK315885	15-55x
EC675178	10-C23	EP309061	11-RL4	HZ527455	2-5	SK315886	15-50
EC675178	10-C36	EP315918	9-3	HZ528581	2-12	SK315888	15-52
ED219464	10-D2	EP315918	14-7	MB428343	2-17	SK315889	15-51x
ED219464	10-D5	EP315936	11-RL5	MB428343	7-1	SK315890	15-53x
ED224550	11-D53to56	EP638706	7-4	MB527556	4-14	SK315932	15-57
ED249377	5-3	ER300820	11-CR1to13	MB606712	9-1	SK315933	15-58x
ED249377	9-6	ER308956	11-R105	MC606712	14-9	SK597633	3-3
ED283138	5-2	ER310844	10-R32	MC315949	9-55	SP301231	15-28x
ED303123	11-D2	ER315937	11-R106	MH243742	12-J1to3	SP301232	15-22x
ED308941	11-D9	ER651532	10-R17	ML301038	9-42	SP301255	15-32x
ED308941	11-D52	ER666854	10-R52	ML301039	9-43	SP305597	15-75
ED308945	11-D1	ER666854	10-R71	ML301056	5-7	SP315836	15-71x
ED308945	11-D3	ER666854	12-R14	ML301103	9-51	SP315839	15-70x
ED308952	11-D10	ES258232	11-SW1	ML301274	9-36	SP315840	15-72x
ED308952	11-D14	ES301205	9-7x	ML314193	6-3	SP315841	15-73x
ED308952	11-D25	ES301207	9-18	ML314216	2-13	SP315891	15-27
ED308952	11-D40,41	ES301433	10-SW2,3	ML314976	9-32	SP315892	15-21x
ED308952	11-D45,46	ES301433	10-SW8	ML396810	9-35	SP315893	15-31
ED308952	11-D51	ES301434	10-SW4	ML528445	7-9	SP315907	15-76x



# INDEX

Parts No.	Ref. No. & Symbol No.	Parts No.	Ref. No. & Symbol No.	Parts No.	Ref. No. & Symbol No.	Parts No.	Ref. No. & Symbol No.
SP315908	15-77x	ZS608264	9-20				
SP315914	15-19	ZS608308	3-4x				
SP315915	15-20x	ZS608310	9-50x				
SZ301132	15-17x	ZS608321	9-30				
SZ315826	15-15	ZS608477	2-3				
SZ315827	15-16x	ZS608501	2-35				
SZ315899	15-6	ZS691277	15-42				
SZ315900	15-7x	ZW259593	2-8				
TC515575	9-37	ZW260043	9-2				
ZG206144	2-32	ZW260076	7-2				
ZG232121	9-49	ZW260188	9-44				
ZG255633	4-3	ZW263946	14-6x				
ZG301072	14-12	ZW265522	2-9				
ZG301073	14-13	ZW270088	4-6				
ZG301340	7-16	ZW270088	7-6x				
ZG313025	9-15	ZW270088	9-5				
ZG315011	4-15	ZW270088	14-10				
ZG317114	2-16	ZW270134	9-45				
ZG321345	7-3	ZW273756	2-15				
ZG456120	5-8	ZW273756	9-24				
ZG466312	2-10	ZW274026	7-11				
ZG514440	9-38	ZW274026	9-21				
ZG516418	9-52	ZW290283	7-15				
ZS201341	15-26x	ZW290283	9-12				
ZS201341	15-30x	ZW301359	2-36				
ZS201341	15-34x	ZW302052	6-4				
ZS201508	3-11	ZW313593	9-40				
ZS201778	2-37	ZW315917	15-44				
ZS297641	15-74x	ZW315929	15-81x				
ZS302720	5-5	ZW334653	9-47				
ZS315844	15-63	ZW393851	9-53				
ZS315923	15-25x	ZW413188	7-14				
ZS315923	15-29x	ZW413188	9-23				
ZS315923	15-33x	ZW413267	8-13				
ZS315930	15-80x	ZW413278	3-9				
ZS322939	15-43x	ZW413278	7-12				
ZS323728	9-26	ZW413278	9-22				
ZS325495	5-4x	ZW420682	9-31x				
ZS325495	8-1	ZW420682	9-46x				
ZS325495	9-19	ZW516993	8-4				
ZS325495	14-2	ZW548010	15-79				
ZS325495	14-11	ZW575763	9-54				
ZS379350	4-8x	ZW597622	3-2				
ZS379350	8-5	ZW616004	9-39				
ZS403222	4-17	ZW625241	14-14				
ZS411660	6-5	ZW668621	2-38				
ZS413201	2-2						
ZS413201	3-10						
ZS413234	15-24x						
ZS417407	2-33						
ZS419670	9-29						
ZS421740	8-7						
ZS421806	8-3						
ZS421806	11-5						
ZS422076	5-9						
ZS422076	7-5						
ZS422076	8-24x						
ZS422076	9-4						
ZS422076	14-3						
ZS422076	14-8						
ZS422965	7-18						
ZS424056	4-12						
ZS424056	8-12						
ZS432674	9-34						
ZS433315	4-11						
ZS444262	7-13						
ZS447840	8-16						
ZS447840	9-25x						
ZS447840	14-15						
ZS460440	2-29						
ZS462194	15-12x						
ZS469710	2-14						
ZS469710	9-41						
ZS477876	2-25						
ZS483502	5-15						
ZS520525	15-78						
ZS558101	12-2						
ZS558101	14-16x						
ZS608095	2-21						
ZS608264	2-7						



---

SECTION 3

**SCHEMATIC DIAGRAM**

1. SCHEMATIC DIAGRAM OF ICs
2. GX-266II NO. 2-1 1581802A AMP SCHEMATIC DIAGRAM
3. GX-266II NO. 2-2 1581803A MECHA SCHEMATIC DIAGRAM

M54410P

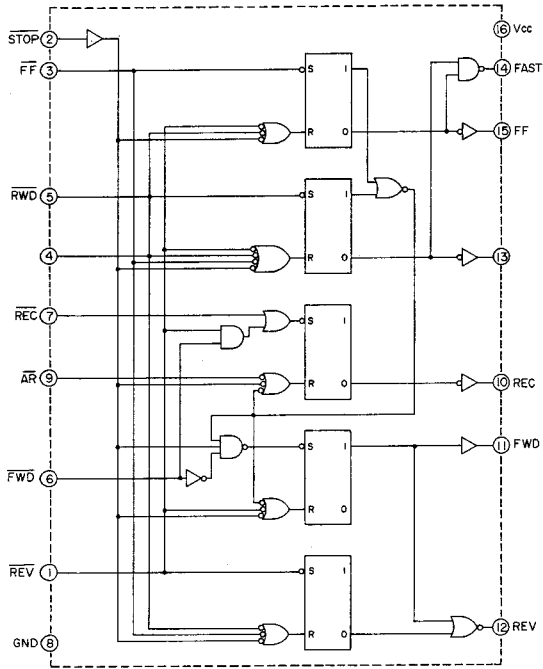

M53200P

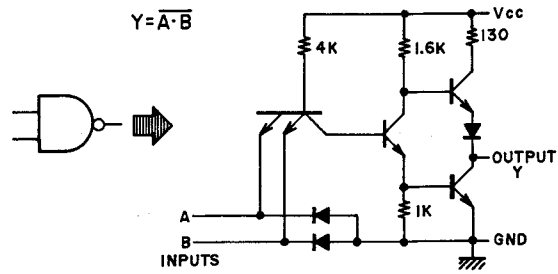
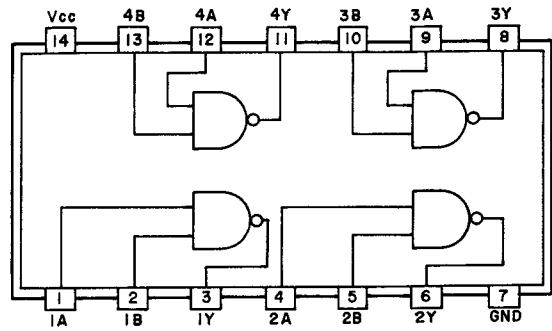

M53202P

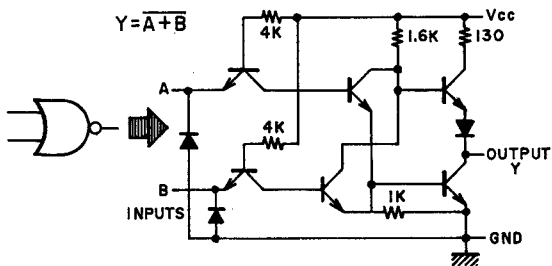
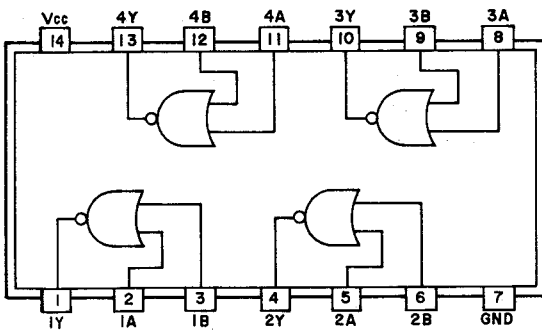

M53204P

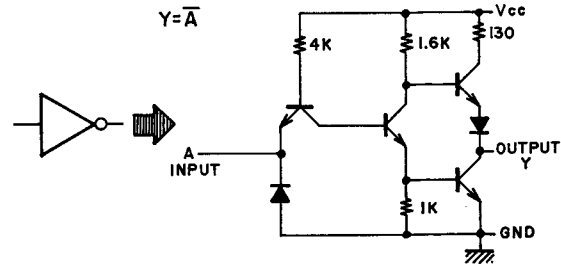
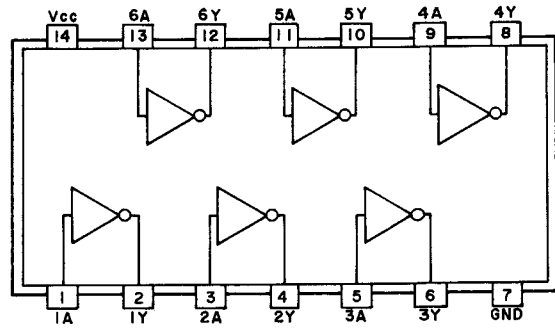

GX-266 II

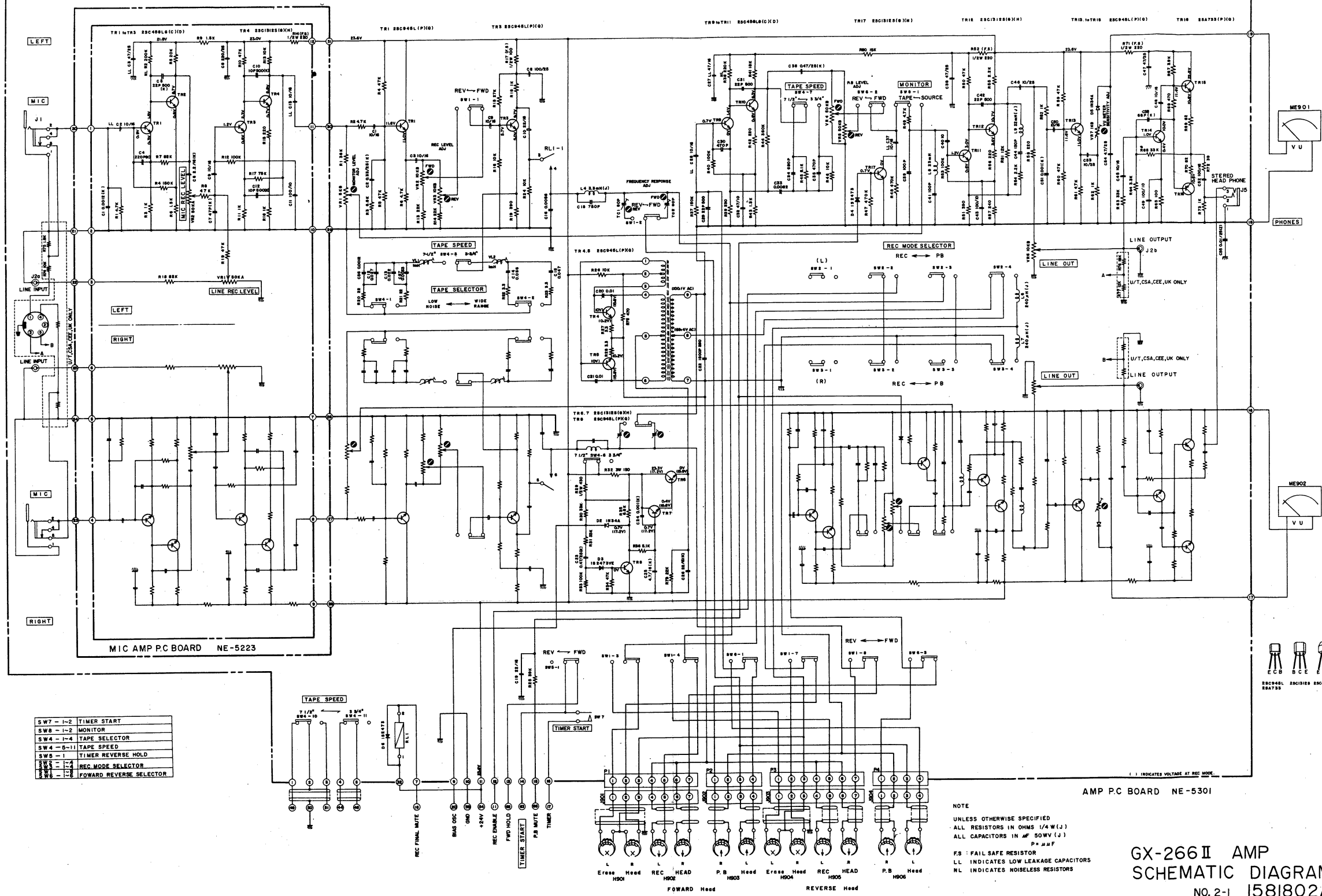

SW 7 - 1-2	TIMER START
SW 8 - 1-2	MONITOR
SW 4 - 1-4	TAPE SELECTOR
SW 4 - 5-11	TAPE SPEED
SW 5 - 1	TIMER REVERSE HOLD
SW 6 - 1-4	REC. MODE SELECTOR
SW 6 - 1-2	FORWARD REVERSE SELECTOR

NOTE  
 UNLESS OTHERWISE SPECIFIED  
 ALL RESISTORS IN OHMS 1/4 W (J)  
 ALL CAPACITORS IN MF 50 WV (J)  
 P = μF  
 FS : FAIL SAFE RESISTOR  
 LL INDICATES LOW LEAKAGE CAPACITORS  
 NL INDICATED NOISELESS RESISTORS

GX-266 II AMP  
 SCHEMATIC DIAGRAM  
 NO. 2-1 1581802A

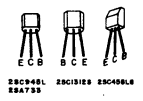

00043

GX-266 II

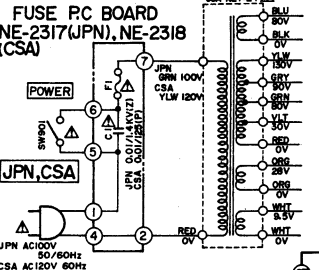
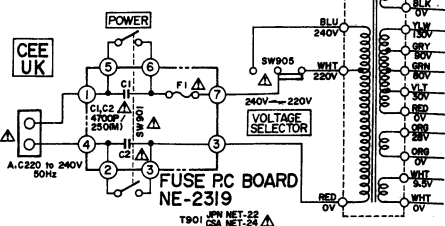

FUSE	JPN	CSA	CEE, UK
F1	250V 2A	125V 2A	T500mA
F2	250V 1.6A	125V 1.6A	T1A
F3	250V 0.8A	125V 0.8A	T500mA
F4	250V 1A	125V 1A	T1A
F5	250V 0.8A	125V 0.8A	T500mA

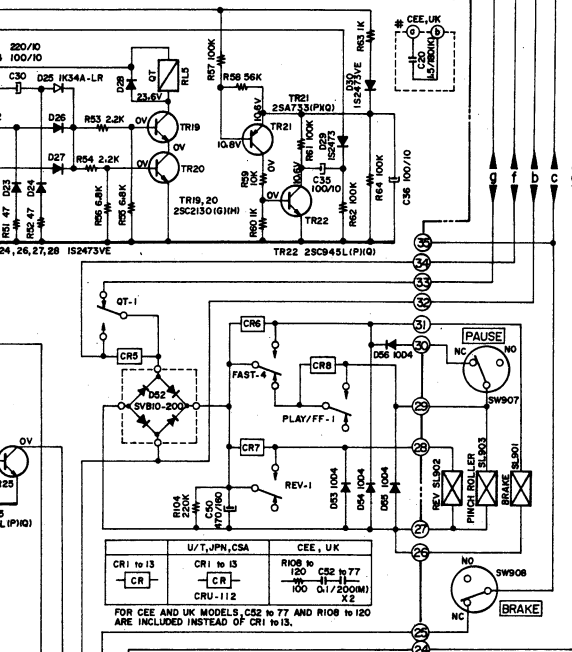
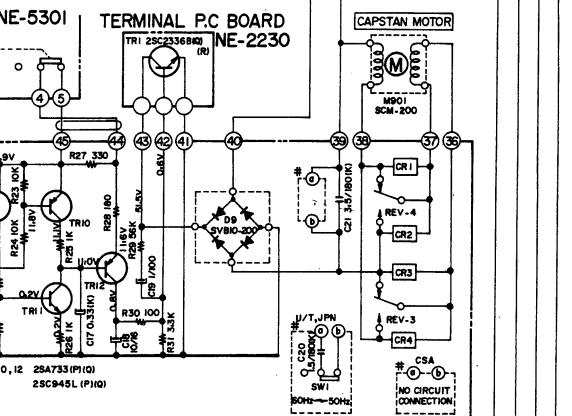
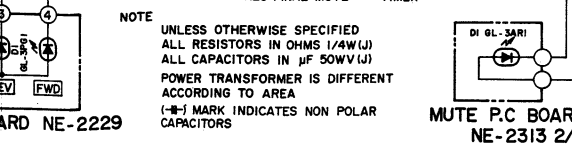
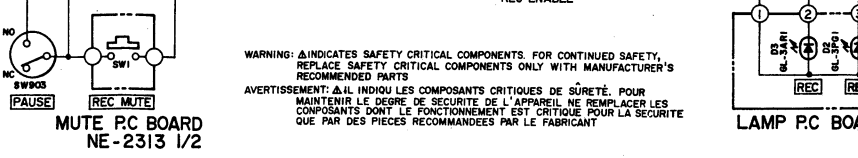
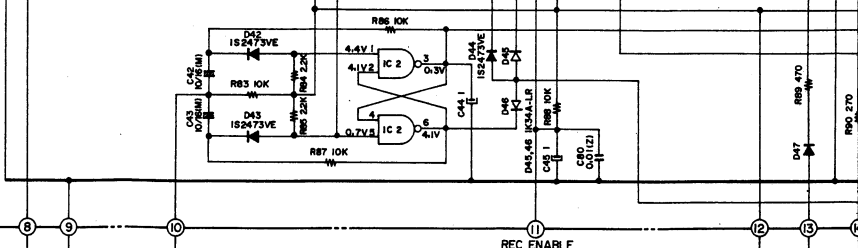
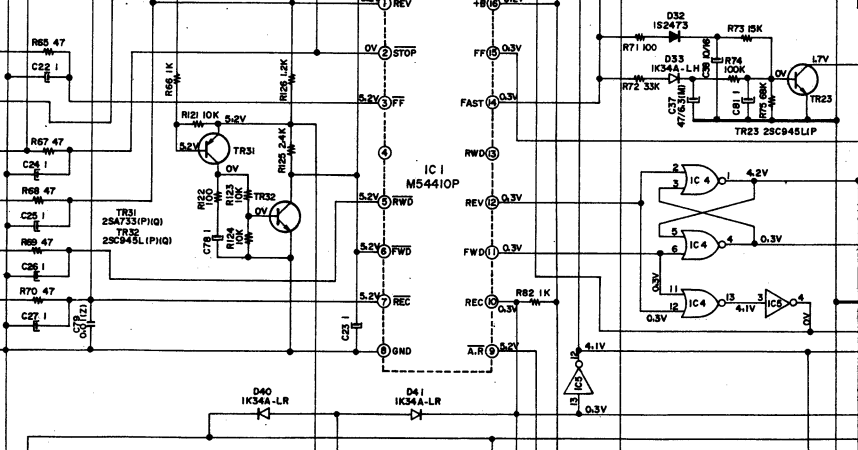
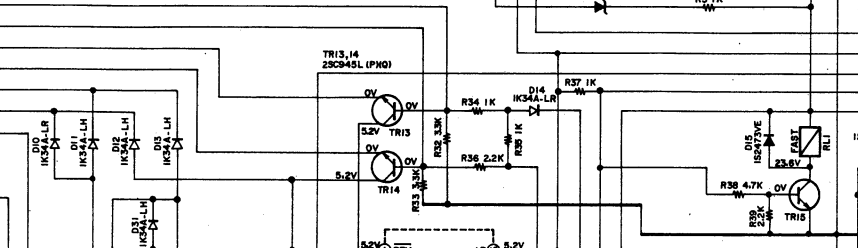
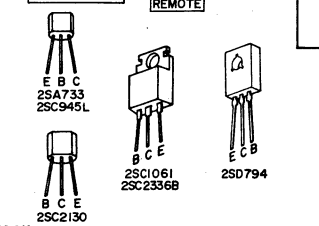
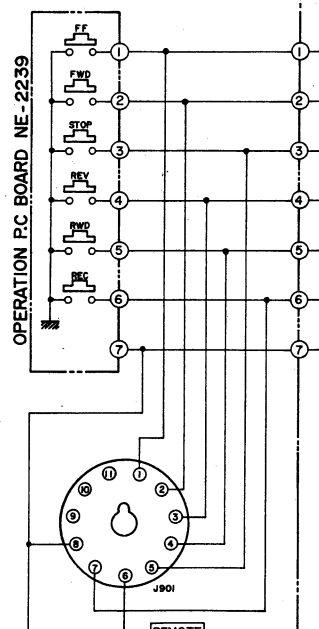
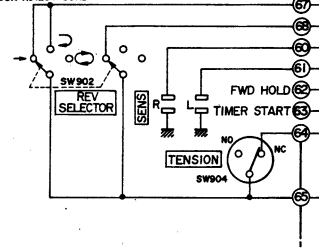
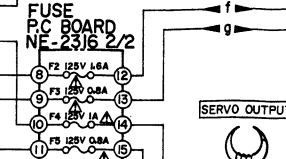
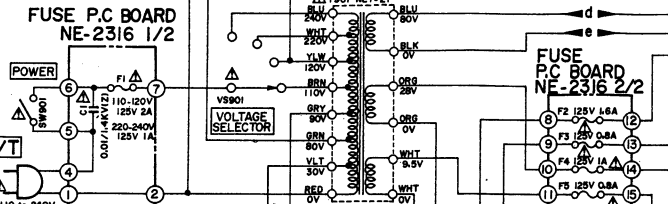

WARNING: Δ INDICATES SAFETY CRITICAL COMPONENTS. FOR CONTINUED SAFETY, REPLACE SAFETY CRITICAL COMPONENTS ONLY WITH MANUFACTURER'S RECOMMENDED PARTS.  
AVERTISSEMENT: Δ IL INDIQUÉ LES COMPOSANTS CRITIQUES DE SÛRETÉ. POUR MAINTENIR LE DEGRÉ DE SÛRETÉ DE L'APPAREIL, NE REMPLACER LES COMPOSANTS DONT LE FONCTIONNEMENT EST CRITIQUE QUE PAR DES PIÈCES RECOMMANDÉES PAR LE FABRICANT.

NOTE  
UNLESS OTHERWISE SPECIFIED  
ALL RESISTORS IN OHMS (1/4W(J)  
ALL CAPACITORS IN μF (50V(J)  
POWER TRANSFORMER IS DIFFERENT  
ACCORDING TO AREA  
(-) MARK INDICATES NON POLAR  
CAPACITORS

**GX-266 II MECHA  
SCHEMATIC DIAGRAM  
NO. 2-2 1581803A**