

SERVICE MANUAL

AKAI TAPE RECORDER

MODEL GX-220

ALSO APPLICABLE TO MODEL **GX-220D**

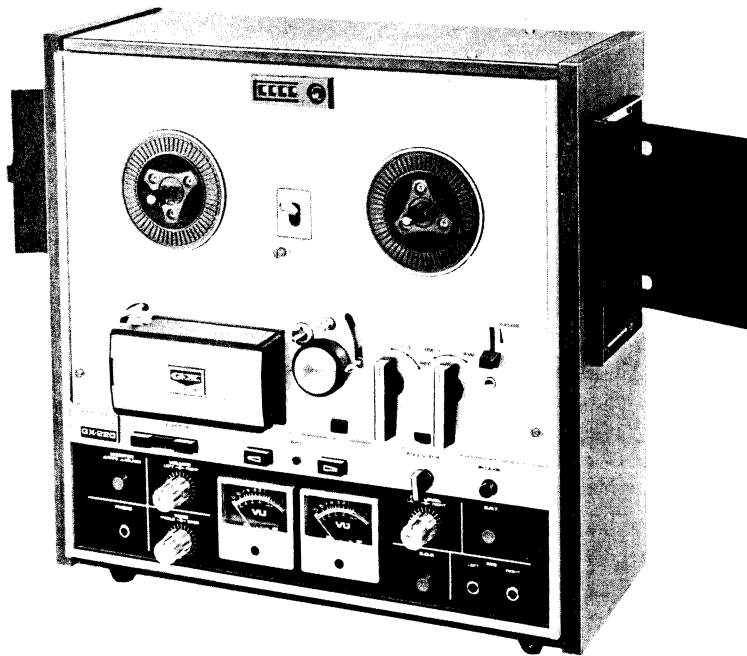

TABLE OF CONTENTS

I.	SPECIFICATIONS	2
II.	MEASURING METHOD	3
III.	CONTROL LOCATIONS	4
IV.	DISMANTLING OF TAPE TRANSPORT UNIT & AMPLIFIERS	5
V.	TRANSPORT MECHANISM	7
VI.	MECHANISM ADJUSTMENT	11
VII.	AMPLIFIER ADJUSTMENT	14
VIII.	MAINTENANCE PROCEDURES	16
IX.	COMPOSITE VIEWS OF COMPONENTS	17
X.	TROUBLE SHOOTING CHART	22
XI.	SCHEMATIC DIAGRAM	

When placing order for parts, please use Separate
PARTS LIST or PRICE LIST FOR PARTS.

I. SPECIFICATIONS

STYLE	: Portable	SPEAKER	: 4" round type 8 Ω 1.5 W (GX-220 only)
WEIGHT	: GX-220 48.8 lbs. (22.2 kg) GX-220D 41.8 lbs. (19 kg)	MOTORS	
DIMENSIONS	: 17.2" (W) x 17" (H) x 9.2" (D) (430 x 425 x 230 mm)	CAPSTAN MOTOR	: Hysteresis Synchronous 3-speed (2-4-8 pole) motor Condenser Capacity 3 μ F (50 Hz) 2 μ F (60 Hz)
POWER SUPPLY	: AC 100 to 240 V, 50/60 Hz	Revolutions	: 3,000-1,500-750 r.p.m. (50 Hz) 3,600-1,800-900 r.p.m. (60 Hz)
RECORDING SYSTEM	: In-line 4-track stereo, monaural GX-Head playback System.	REEL MOTOR	: Two 6-pole eddy current outer-rotor motors.
PLAYBACK SYSTEM	: In-line 4-track stereo, monaural GX-Head Playback System.	Revolutions	: 930 r.p.m. at 50 Hz 100 V 1,120 r.p.m. at 60 Hz 110 V
TAPE SPEED	: 1-7/8, 3-3/4 and 7-1/2 ips.	HEADS	
TAPE SPEED DEVIATION	: Within \pm 0.7%	REC. HEAD	: (Interchangeable with Models GX-365 and GX-280D). : In-line 4-track stereo and monaural Glass and Crystal Ferrite Head. Impedance 15 Ohms at 1,000 Hz. Gap 4/1,000 mm
WOW AND FLUTTER		ERASE HEAD	: (Interchangeable with Models 1730-SS and GX-280D). : In-line 4-track stereo/monaural. Impedance 300 Ohms at 100 KHz. Gap 0.4 mm
(Playback only)	: Less than 0.1% r.m.s. at 7-1/2 ips. Less than 0.2% r.m.s. at 3-3/4 ips. Less than 0.3% r.m.s. at 1-7/8 ips.	PLAYBACK HEAD	: (Interchangeable with Models GX-365 and GX-280D) : In-line 4-track stereo/monaural Glass and Crystal Ferrite Head. Impedance 2,500 Ohms at 100 KHz. Gap 2/1,000 mm
FREQUENCY RESPONSE	: 30 to 24,000 Hz \pm 3 dB at 7-1/2 ips. 30 to 18,000 Hz \pm 3 dB at 3-3/4 ips. 40 to 9,000 Hz \pm 4 dB at 1-7/8 ips.	RECORDING LEVEL INDICATOR	: Two VU Meters.
SIGNAL TO NOISE RATIO	: Better than 48 dB (Forward Operation) Better than 45 dB (Reverse Operation)	IC USED	: 2 STK-015 (GX-220 only)
DISTORTION	: Within 2% at Line Output, 1,000 Hz 0 VU 0 VU Recording and Playback.	TRANSISTORS USED	: 12 2SC871 (F) 2 2SC971 (2, 3) 6 2SC945 (Q, R) 1 2SC1211 (C, D) 1 2SC372 2 LD-3141 1 2SD205
CROSS TALK	: Less than -65 dB (Monaural) Less than -43 dB (Stereo)	DIODES USED	: 6 IN34A 1 10D4 15B2 (GX-220 only) 5 10D1 1 RD24A (M)
ERASE RATIO	: Less than -70 dB	REELS USED	: 7", 5", 3" reels
INSULATION RESISTANCE	: More than 50 M Ohms		
INSULATION DURABILITY	: 500 V. AC for more than one minute duration.		
POWER OUTPUT	: (8 Ω Speaker) more than 10 W.		
LINE OUTPUT	: Required load impedance more than 20 K Ohms. 1.23 V (+4 dBs)		
DIN OUTPUT	: 0.4 V Required Load Impedance more than 50 K Ohms.		
LINE INPUT	: Above 50 mV (-25 dBs) Impedance 150 K Ohms.		
DIN INPUT	: High Above 50 mV (-25 dBs). Impedance 150 K Ohms. Low Above 5 mV (-45 dBs). Impedance 27 K Ohms.		
MIC. INPUT	: Above 0.2 mV Impedance 10 K Ohms.		
FAST FORWARD AND REWIND TIME	: 85 seconds for a full 1,200 foot tape at 50 Hz. 65 seconds for a full 1,200 foot tape at 60 Hz.		

II. MEASURING METHOD

TAPE SPEED DEVIATION

1. Method involving use of pre-recorded tape
Playback tape pre-recorded at 1000 Hz ($\pm 0.1\%$) on recorder to be tested. Connect the appropriate output to a frequency counter meter in order to measure the tape speed deviation.
2. Method involving use of timing tape. (designed for tape speed measurement)
This method utilizes a timing tape marked at intervals of 7-1/2". The running time of over 60 marked sections of tape is measured in order to calculate the deviation of the tape speed. In applying this method, however, it should be kept in mind that timing tape stretch or contract measurement error is inevitable, so that it is necessary to measure the total length of the tape in advance.

WOW AND FLUTTER

Playback a 3,000 Hz pre-recorded tape, of which the wow and flutter level is guaranteed to be smaller than 0.07%, and measure with a wow meter. It is also possible for a 3,000 Hz sine wave to be recorded and played back for measurement with a wow meter. In this case, however, the wow meter will indicate a value as much as twice that given in the specifications.

FREQUENCY RESPONSE

RECORD :

- 1) Supply a sine wave of 1,000 Hz to the Line Input of the recorder to be tested through an attenuator from an audio frequency generator.
- 2) Set the Record/Playback Lever to "Rec" position and adjust the line input volume so that the VU Meter needle indicates "0" VU.
- 3) Set the Equalizer Switch to 7-1/2" or 3-3/4" position.
- 4) Under the condition described in (2), lower the input level 16 dB by means of the attenuator.
- 5) Record the spot frequency in the range of 30 Hz to 25,000 Hz from the audio frequency generator.

PLAYBACK :

- 6) Set the Record/Playback Lever to "Play" position.
- 7) Connect a Vacuum Tube Volt Meter to the Line Output Jack. (VTVM with milli volt scale.)
- 8) Playback the recorded tape.
- 9) Playback the recorded spot frequencies and make a memo of output level and plot the value on a graph.

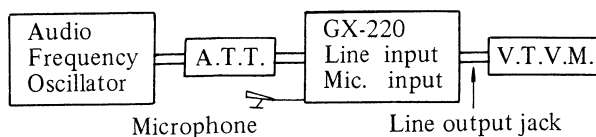

TOTAL HARMONIC DISTORTION FACTOR

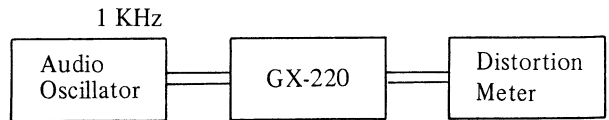

Connect the measuring instrument as shown above, and record the 1,000 Hz sine wave at "0" VU. Playback the resulting signal and measure the overall distortion factor. Measure the noise level of the tape recorder with the tape removed; connect the audio oscillator directly to the distortion meter for measurement of the distortion factor of the oscillator.

The required distortion factor can be obtained from the results of the above measurement by the following formula :

$$d_0 = d - d_1 - d_2$$

where, d_0 = Required

d = Overall distortion factor

d_1 = Noise level

d_2 = Distortion factor of the oscillator

(Note : New tape of particularly good quality should be used for measurement of the distortion factor.)

SIGNAL TO NOISE RATIO

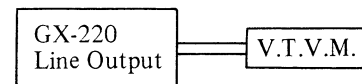

Set the Equalizer Switch to "7-1/2 ips" position and playback a tape containing a 250 Hz sine wave recorded at "0" VU level on a standard recorder. Connect a V.T.V.M. to the line output jack of the recorder and measure its output. Then remove the tape and measure the noise level under the same condition. Convert into decibels each of the measured values.

CROSSTALK (Crosstalk between the tracks)

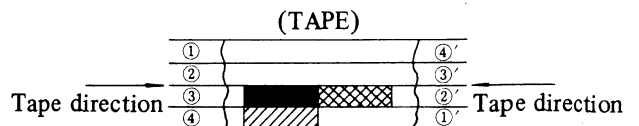

As shown in the figure, first record a 1,000 Hz sine wave on track No. 3 at +3 VU level. Next, remove the 1,000 Hz input signal and record under a non-input condition. Then, playback the tape on track No. 3 and No. 1 (reversed condition of tape) through the 1,000 Hz B.P.F. (Band Pass Filter, Sensitivity . . . 1 : 1) and obtain a ratio between the two from the following formula.

$$C = 20 \log \frac{E_0}{E_2 - E_1} \text{ (dB)}$$

C = Desired crosstalk ratio (dB)

E_0 = 1,000 Hz signal output level

E_2 = 1,000 Hz crosstalk output level

E_1 = Non-input signal record level

III. CONTROL LOCATIONS

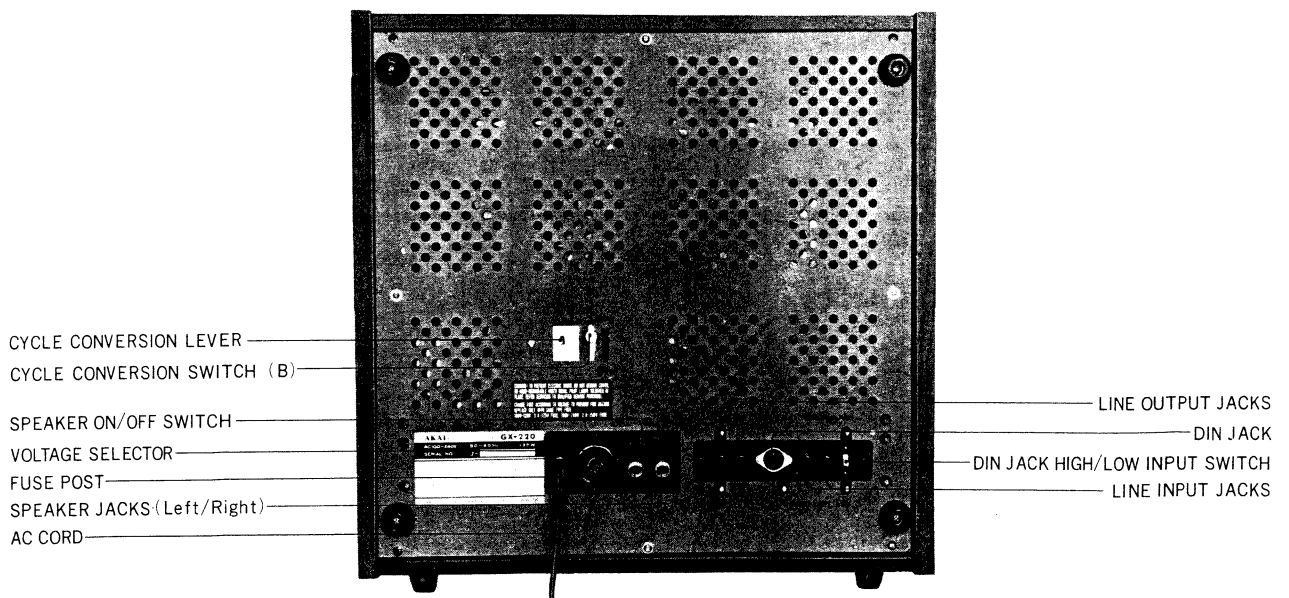
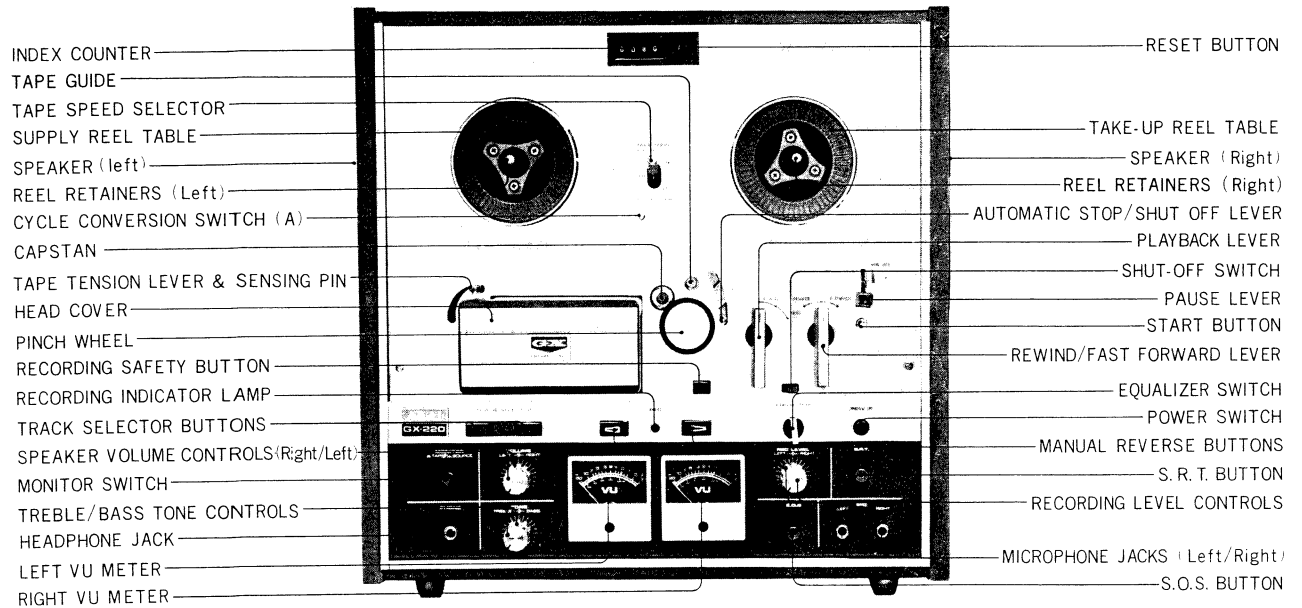

IV. DISMANTLING OF TAPE TRANSPORT UNIT & AMPLIFIERS

In case of trouble, etc. necessitating disassembly, please disassemble in the order shown in photographs. Reassemble in reverse order.

1

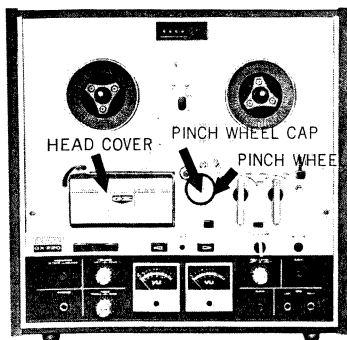

2

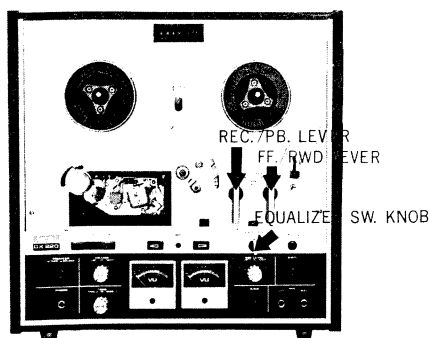

3

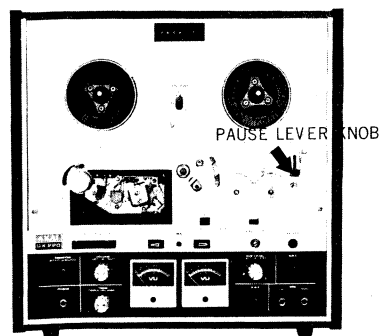

4

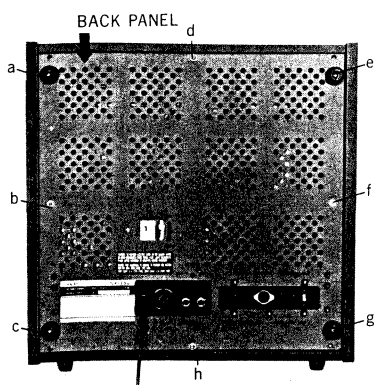

5

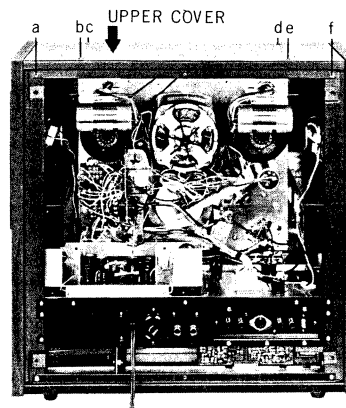

6

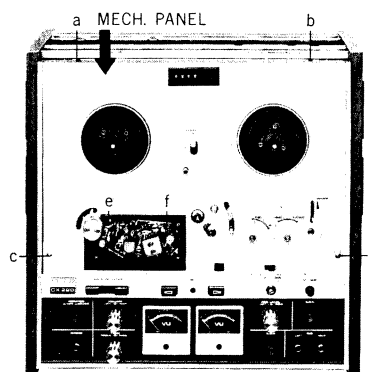

7



8

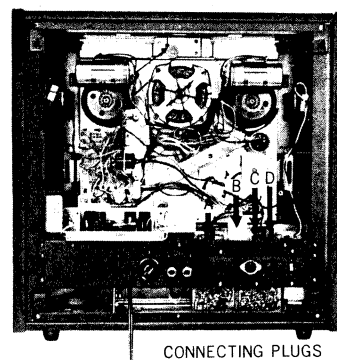

9

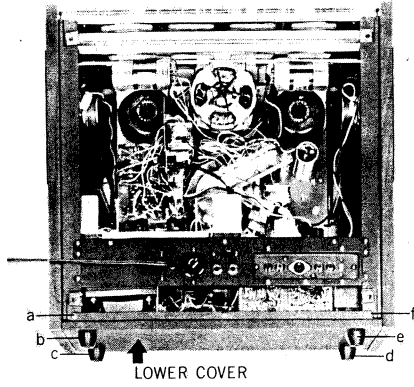

13

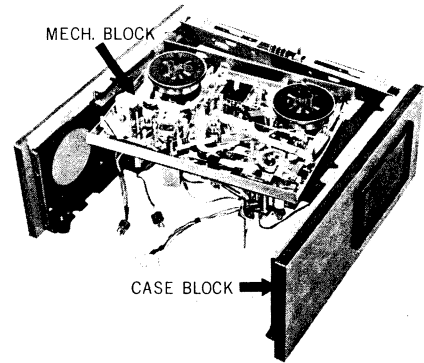

10

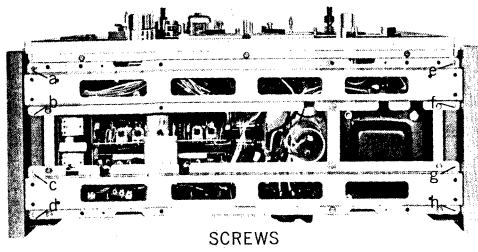

14

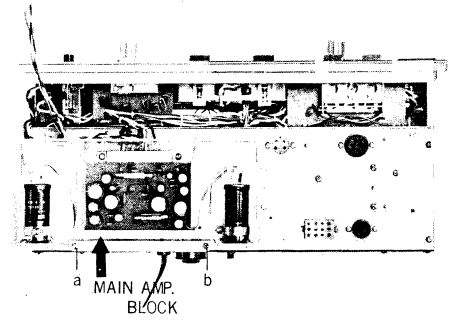

11

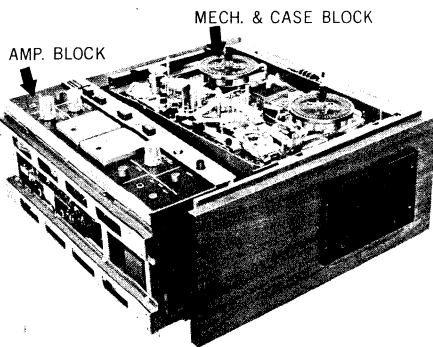

15

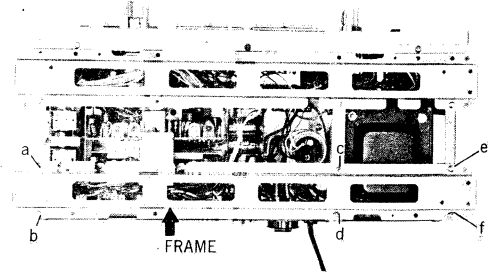

12

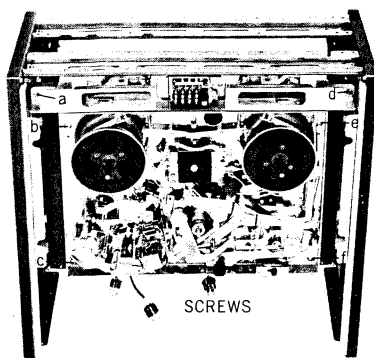

16

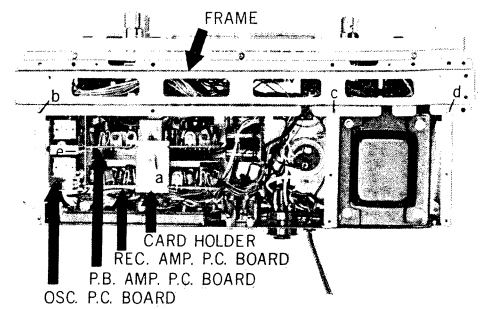

V. TRANSPORT MECHANISM

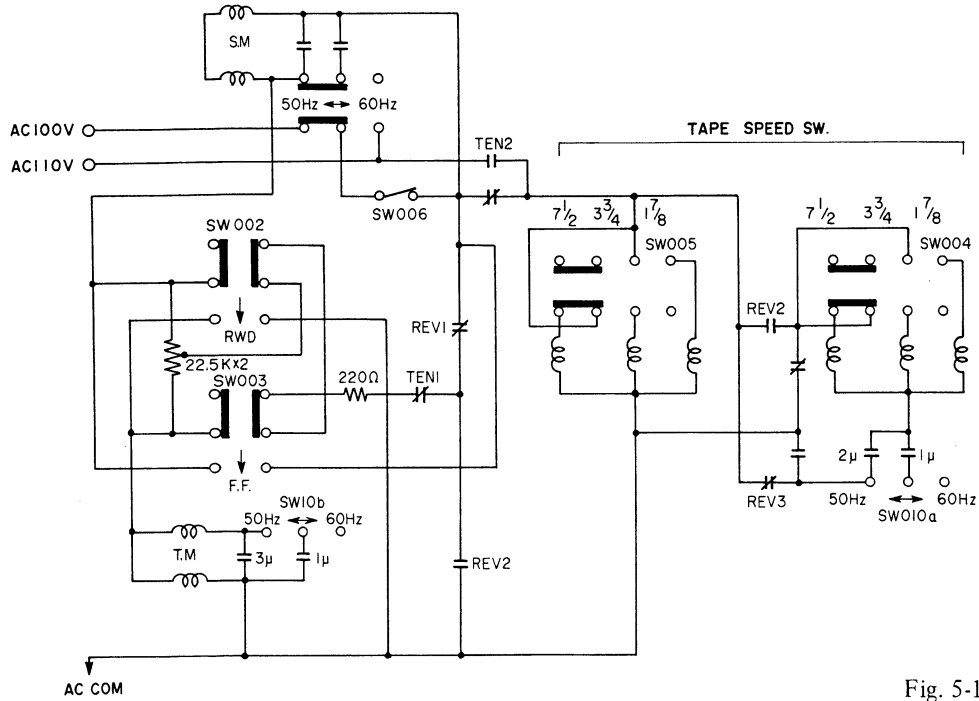

Fig. 5-1

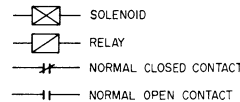
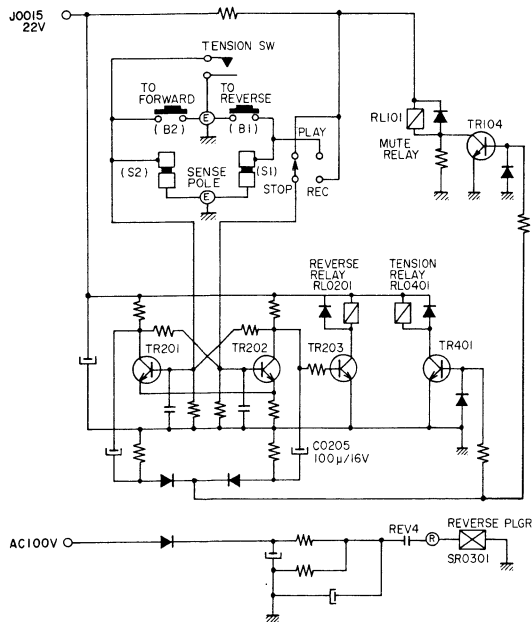

Fig. 5-2

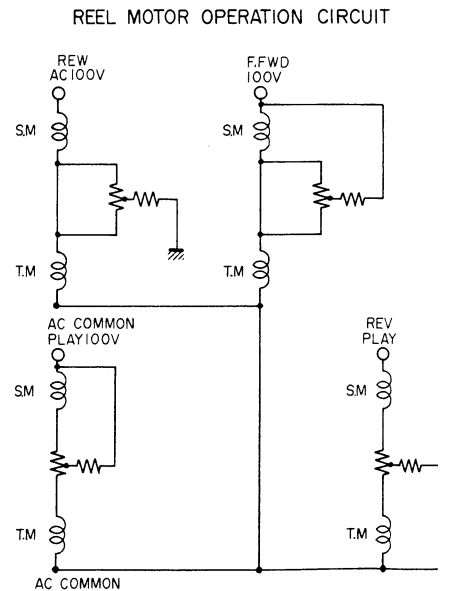

Fig. 5-3

1. SUPPLY VOLTAGE OF BOTH TORQUE MOTORS DURING RECORDING/PLAYBACK

	SUPPLY	TAKE-UP
Normal Play	30 V (50 to 60 gr)	60 V (180 gr)
First 4 to 8 sec. of reverse	47 V (100 gr)	47 V (100 gr)
Reverse	60 V (180 gr)	30 V (50 to 60 gr)
RW-FF	100 V	100 V

2. PINCH ROLLER PRESSURE 1.5 Kgr TO 1.8 Kgr.

Recording/Playback (Normal Recording)

Set Recording/Playback Lever (A) to Playback Position. The Pinch Roller presses against Capstan to move the tape at the rated speed. The Brake Levers free the Brake and Lever Spring (G) turns "ON" Microswitch (SW006) (F) so that both torque motors become operative (as shown in diagram illustration).

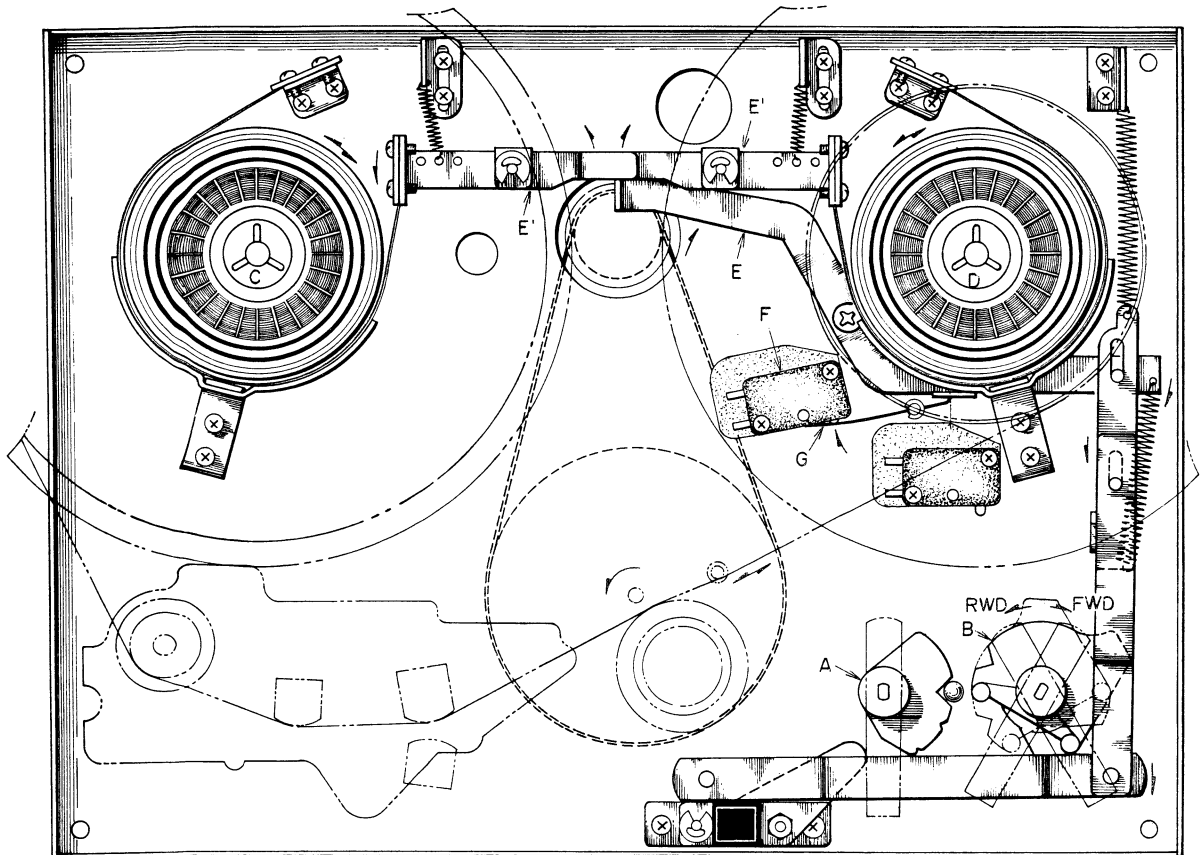

FAST-FORWARD/REWIND

Fig. 5-4

3. REVERSE (BLOCK DIAGRAM ILLUSTRATION)

During Playback mode, when Reverse button (B) is depressed or the sensing tape passes the sensing pole (S₁), the base of TR0202 is grounded. The operation of TR0202 is stopped and the voltage sent to the base of TR0203 and operates it. Reverse Relay RL0201 is actuated and Reverse is effected.

At the same time, the discharge current of Condenser C0205 (100 M/16 V) actuates TR0401 and TR104 which assume operating position within a period of from 4 to 8 seconds.

Tension Relay (RL0401) is actuated and a higher voltage than during reverse playback time (47 V) is supplied to the Take-Up torque motor. At the same time Mute Relay (CRL1017) mutes the playback output signal.

Plunger (SR0301) operates and lowers the playback head. (See Fig. 5-4)

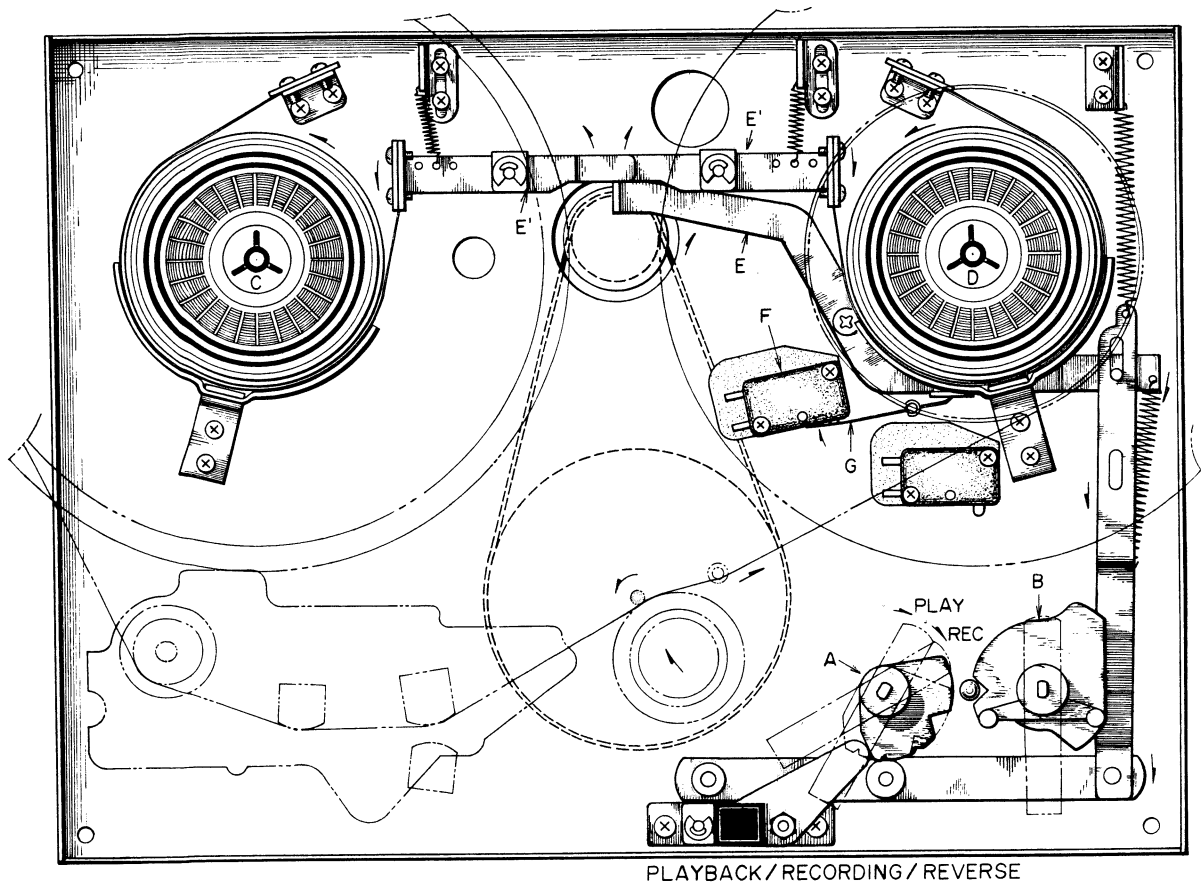

Fig. 5-5

4. FAST FORWARD

When Fast Forward/Rewind Lever is set to Forward position, SW003 (block diagram) enters forward position. Brake Levers (E) free brake. Lever Spring (G) turns "ON" Microswitch (F) and the TAKE-UP Torque Motor rotates. (See Fig. 5-5)

5. REWIND

When Fast Forward/Rewind Knob is set to Rewind position, SW002 (block diagram) enters rewind position. Brake Levers (E) free Brake. Lever Spring (G) turns "ON" Microswitch (F) and the SUPPLY Torque Motor rotates. (See Fig. 5-5)

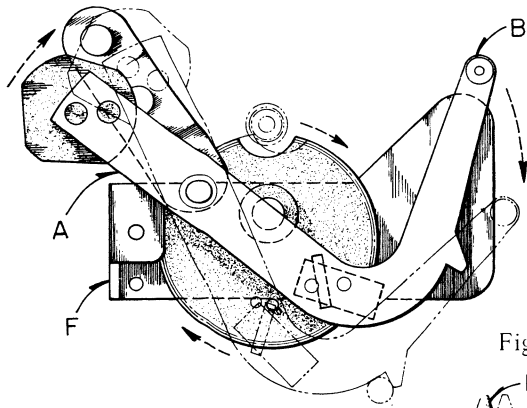

Fig. 5-6

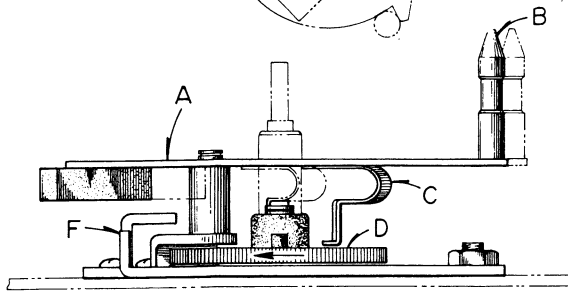

Fig. 5-7

AUTOMATIC STOP MECHANISM

When the tape is threaded on pin (B), if the tape is accidentally broken or comes to the end, Automatic Stop Lever (A) drops to its original position.

When the tape is broken or comes to the end, Plate Spring (C), located below the Automatic Stop Lever, depresses a projected pin on Eccentric Gear (D). Eccentric Gear (D) gears into Flywheel (E) to begin rotation of the Eccentric Gear. This rotating action operates Lever (L), which is connected to the base of the Eccentric Gear, and pushes up Instant Stop Lever (G). When Instant Stop Lever (G) is lifted, Shut-Off Lever (J) contacts Micro Switch (K) and the current supply is cut off. Thus, automatic stop control is provided in Recording and Playback modes.

In Fast Forward and Rewind modes, the same operation takes place except that Lever (H) works to push back the FF, Rewind Shaft to "Stop" position.

(See Figs. 5-6 to 5-9)

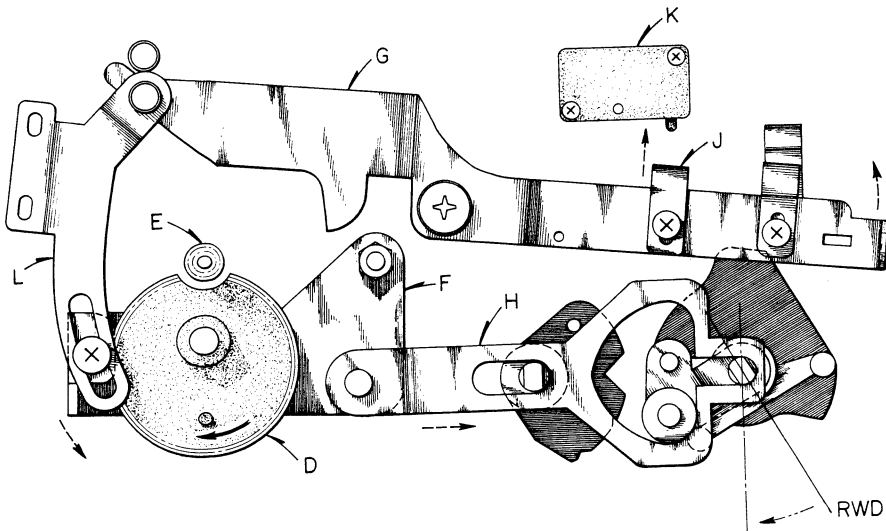

RWD Fig. 5-8

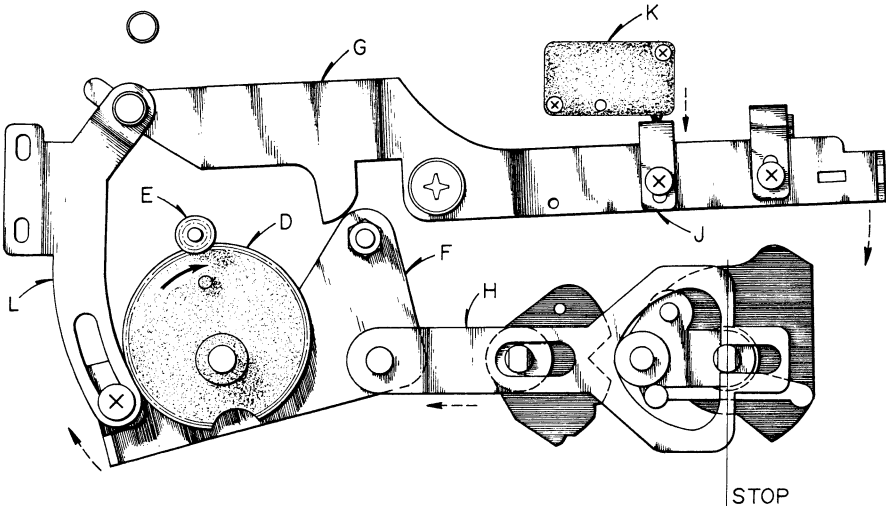

Fig. 5-9

VI. MECHANISM ADJUSTMENT

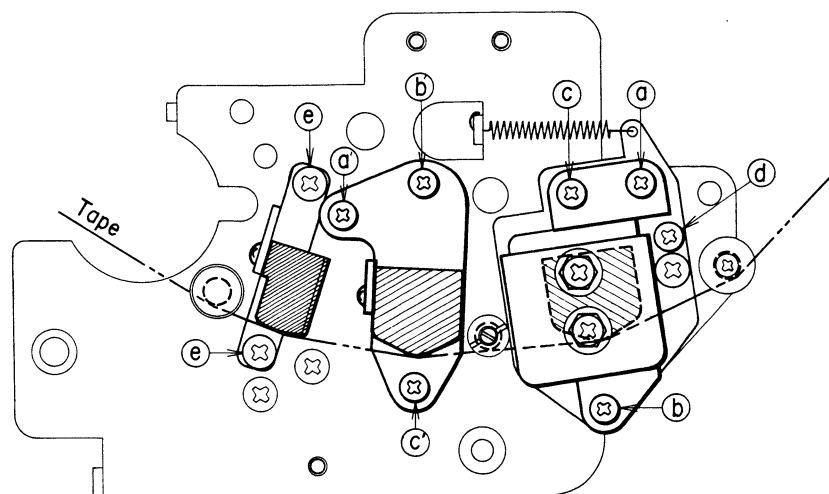

Fig. 6-1

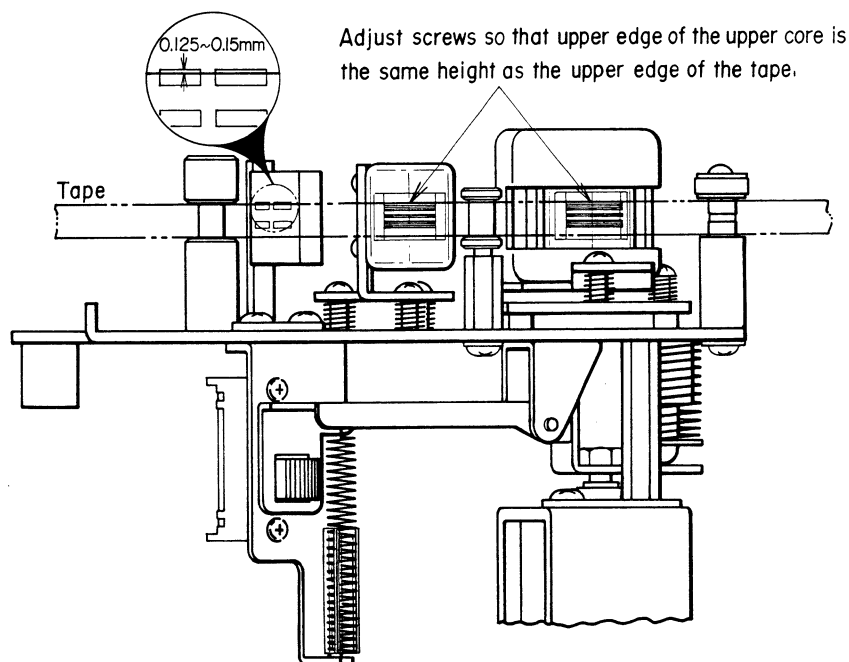

Fig. 6-2

1. ADJUSTMENT OF HEAD HEIGHT (See Figures 6-2 and 6-3).

- 1) During Normal Play, adjust screws (a') (b') (c') (Fig. 6-1) so that the upper edge of the upper core of the Playback and Recording Head is the same height as the upper edge of the tape. During Reverse Play, adjust screw (d) (Fig. 6-1) so that the lower edge of the lower core is the same height as the lower edge of the tape.
- 2) Erase Head
The upper edge of the upper core is 0.125 to 0.15 mm higher than the upper edge of the tape. The front of the head should be at right angles to the chassis and the upper and lower part of the head should firmly contact the tape.

2. ADJUSTMENT OF AZIMUTH ALIGNMENT

- 1) Playback Head
Use a pre-recorded tape (16 kHz, 7-1/2 ips) and connect a high sensitivity V.T.V.M. to the line output jack. Adjust screws (a) (b) so that the line output voltage is maximum and the output error between left and right channel is within 2 dB. This 2 dB margin should be maintained during normal reverse (both directions).
- 2) Recording Head
After the above adjustments have been made, at 7-1/2 ips speed, supply a 15 KC-10 dB signal from the Line and adjust screw (a') so that this output is maximum.

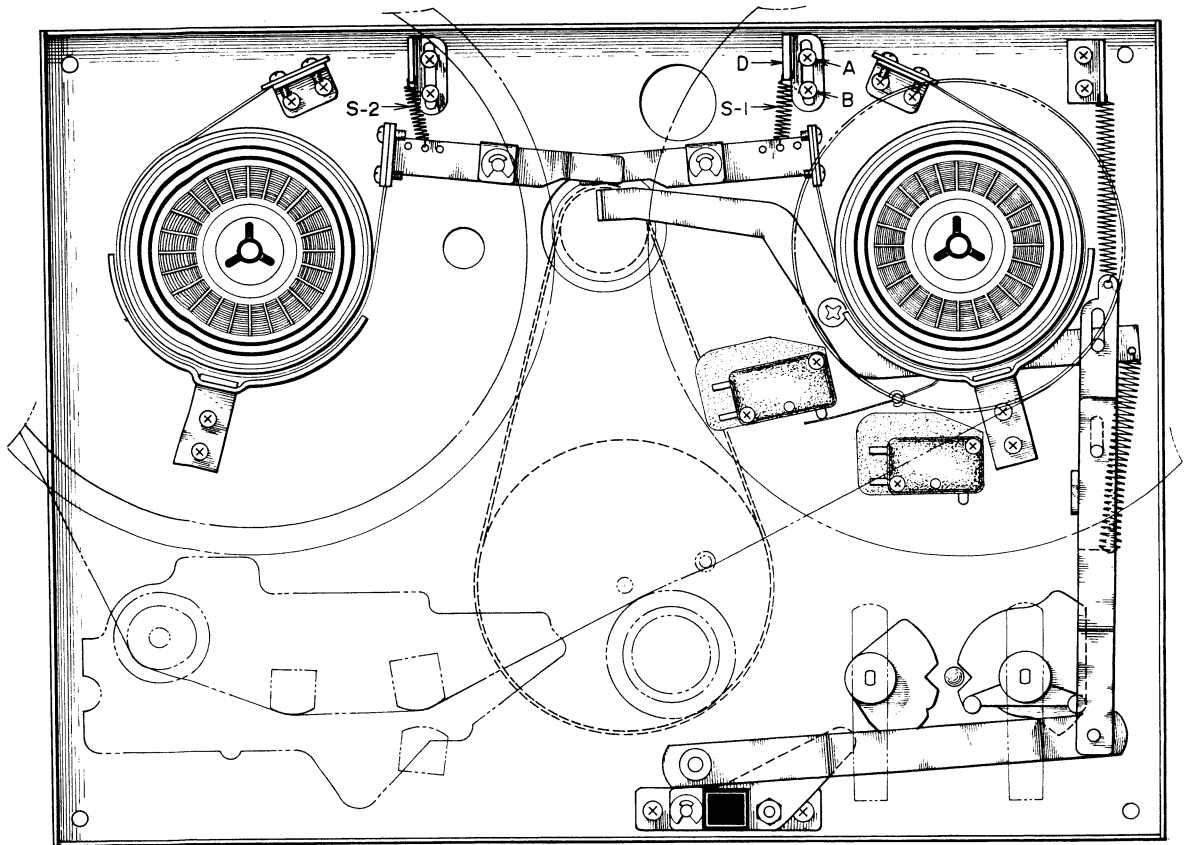

Fig. 6-3

BRAKE ADJUSTMENT

Using a Tension Gauge, and a 60 mm tape wound on a 5" Reel, measuring can be accomplished as per drawing. Measure the brake tension as shown in the drawing. 300 gr is standard.

To regulate tension, change the position of the suspended springs (S_1 and S_2 in Fig. 6-3) or loosen screws (A) (B) and regulate position of the spring suspension metal fitting (D).

REEL HEIGHT ADJUSTMENT (SEE DIAGRAM ILLUSTRATION)

Loosen Reel Table Screws and regulate height.

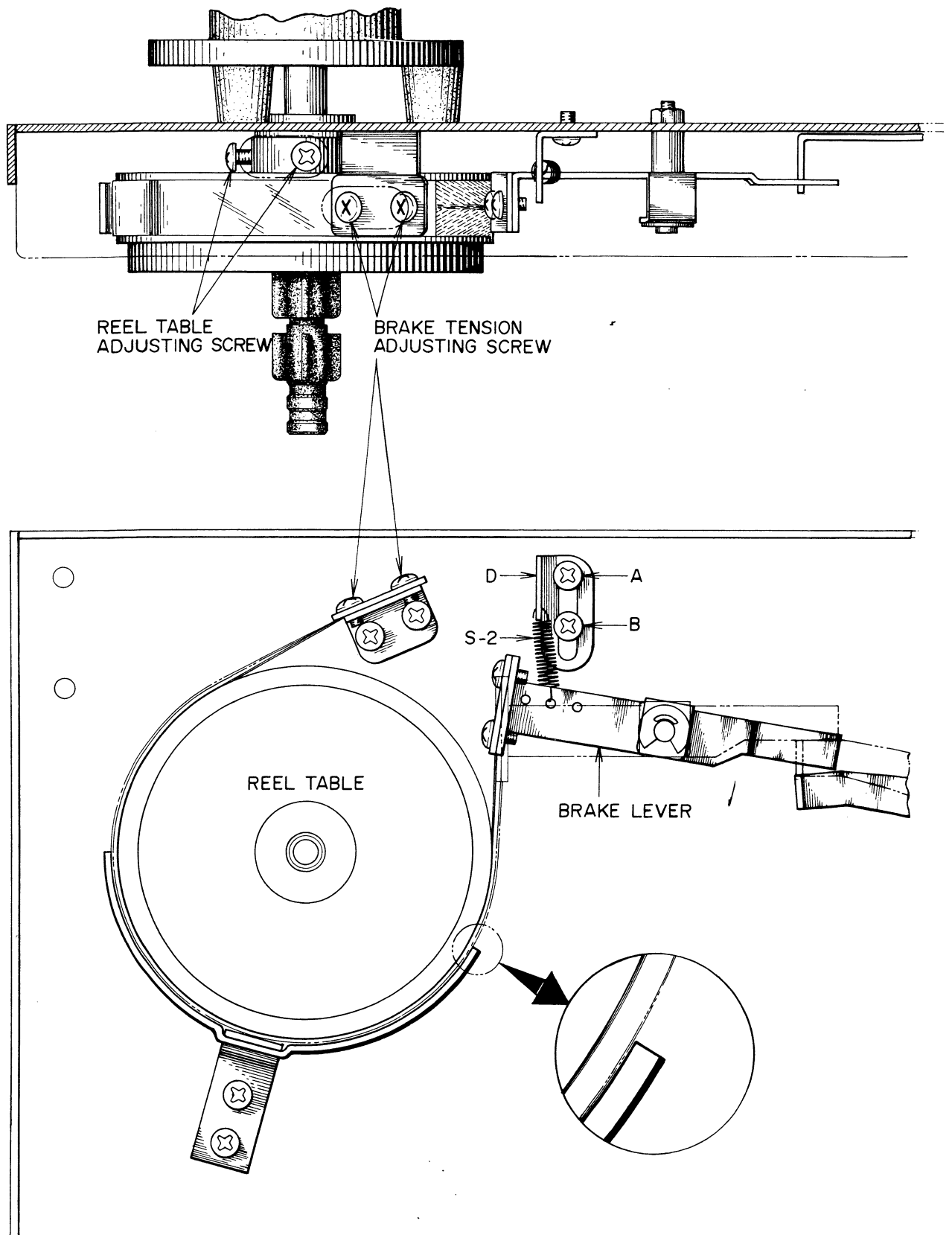

Fig. 6-4

VII. AMPLIFIER ADJUSTMENT

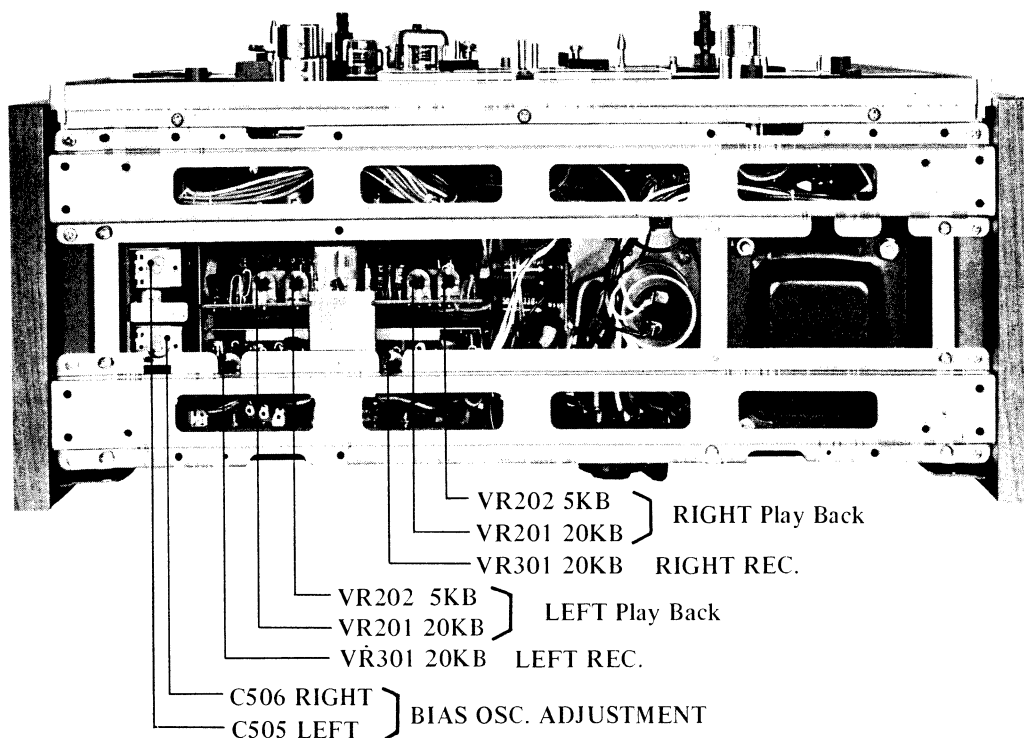

Fig. 7-1

1. PLAYBACK OUTPUT LEVEL (PRE-AMPLIFIER) ADJUSTMENT

- Connect a high sensitivity V.T.V.M. to the Line Output Jack.
- Set the Tape Speed Selector Switch to "7-1/2" and set the Monitor Switch to "TAPE" position.
- Play back a 250 Hz pre-recorded tape.
- Adjust VR-201 (semi-fixed resistor 20 KB, Fig. 7-1) of the pre-amplifier so that the Line Output Voltage is 1.228 V (+4 dBm).
- Adjust VR-202 (semi-fixed resistor 5 KB, Fig. 7-1) of the pre-amplifier so that the VU Meter Needle indicates "0" VU (intermediate between red and white).

2. VU METER SENSITIVITY ADJUSTMENT

After the above Playback Output Level Adjustment has been completed, adjust VR-202 (semi-fixed resistor 5 KB) of Playback Print Board (MS-5022) so that the VU Meter indicates exactly "0" VU.

3. ADJUSTMENT OF RECORDING LEVEL

Recording Amplifier Adjustment should be made only after Head Adjustments (Vertical and Horizontal Azimuth) and Playback Amplifier Adjustments have been made.

- As shown in Fig. 7-2, connect an Audio Oscillator and Attenuator to the Line Input and connect a high sensitivity V.T.V.M. to the Line Output.
- Load a blank (Fuji S-100) tape.
- Set Equalizer Switch and Tape Speed Selector to "7-1/2" position and set the Monitor Switch to "TAPE" position.
- Supply a 1000 Hz signal from the Audio Oscillator to the Line Input.
- While depressing REC Safety Button, set Playback Lever to "REC" position and record.
- Adjust the Line Level Control so that the VU Meter Needle indicates "0" VU.
- Set the Monitor Switch to "SOURCE" position. Adjust VR-301 (semi-fixed resistor 20 KB) of Recording Amplifier Board so that the VU Meter Needle indicates "0" VU.

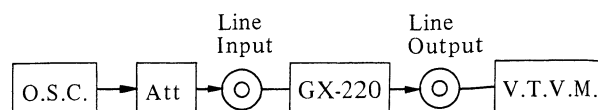

Fig. 7-2

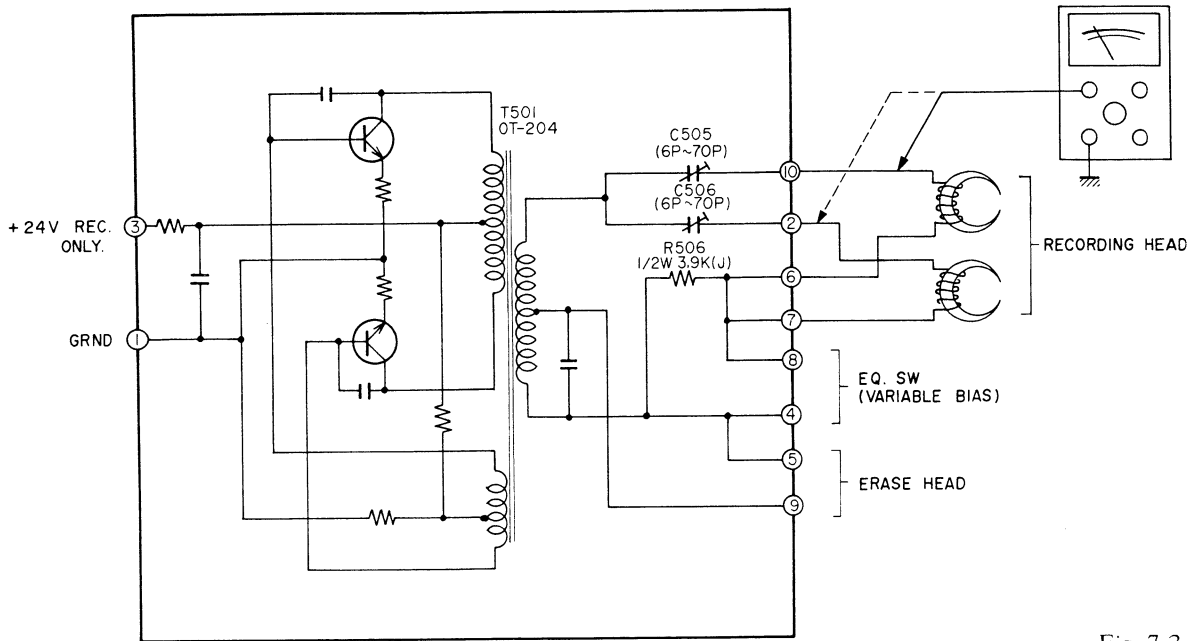

Fig. 7-3

4. ADJUSTMENT OF RECORDING BIAS FREQUENCY AND VOLTAGE

Proper Bias Frequency of the GX-220 (GX-220D) is 100 KC (± 5 KC). Proper Bias Voltage is 5 V ($+/-2$ V). The voltage can be adjusted by turning VC (C-505, C-506) in the Bias Oscillator Circuit.

Erasing Voltage is about 30 V.

Caution :

Always be sure to demagnetize the heads following the above adjustments.

VIII. MAINTENANCE PROCEDURE

1. LUBRICATION INSTRUCTION

For maximum service life and optimum performance, lubricate the parts identified below after each 500 hours of operation. Use only light machine oil of good quality.

Motor

Flywheel Assembly

Pinch Wheel 1 drop

Also apply a liberal film of light machine grease to each roller surface of all levers and cams.

CAUTION : DO NOT OVER-LUBRICATE. WIPE OFF EXCESS OIL WITH A COTTON SWAB SOAKED IN ALCOHOL. OTHERWISE, THE EXCESS LUBRICANT MAY BE SCATTERED DURING OPERATION AND THE RUBBER COMPONENT PARTS WILL DETERIORATE.

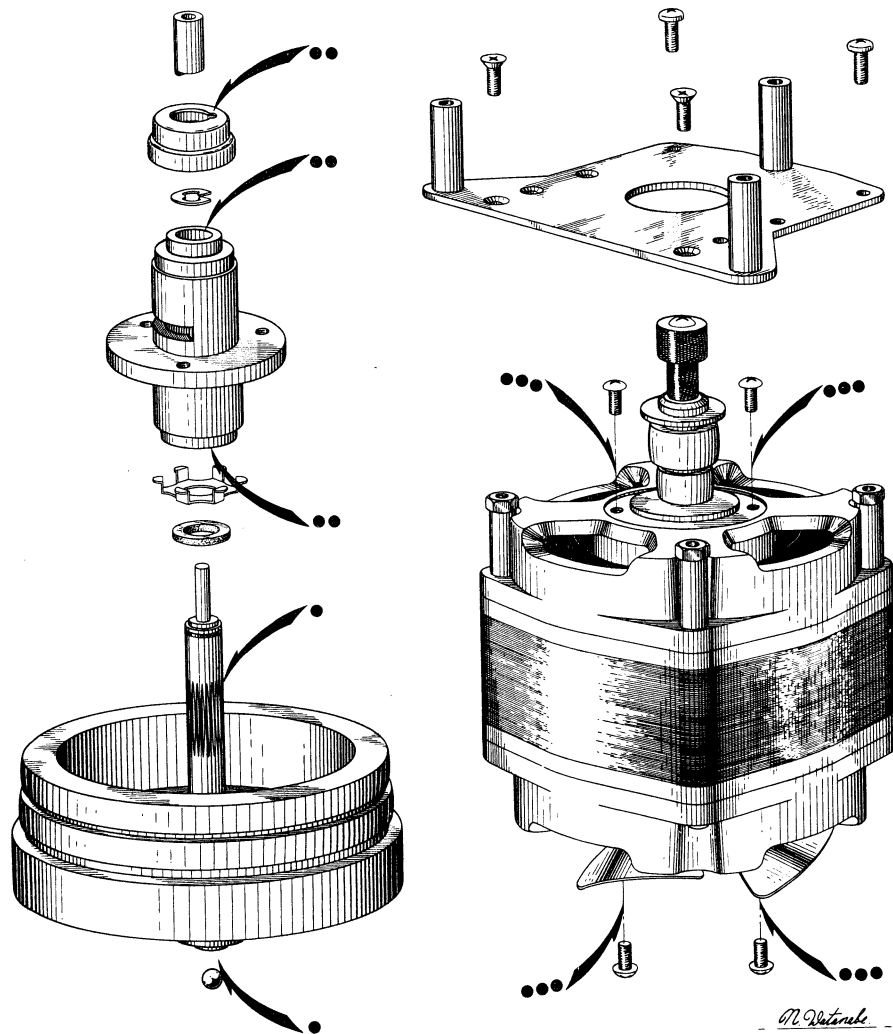

2. CLEANING TAPE HEADS AND OTHER PARTS

Wipe surface of tape heads, guide roller bearing, capstan bushing and pinch wheel periodically with a soft cloth soaked in alcohol.

IX. COMPOSITE VIEWS OF COMPONENTS

SYSTEM CONTROL P.C. BOARD (MR-504)

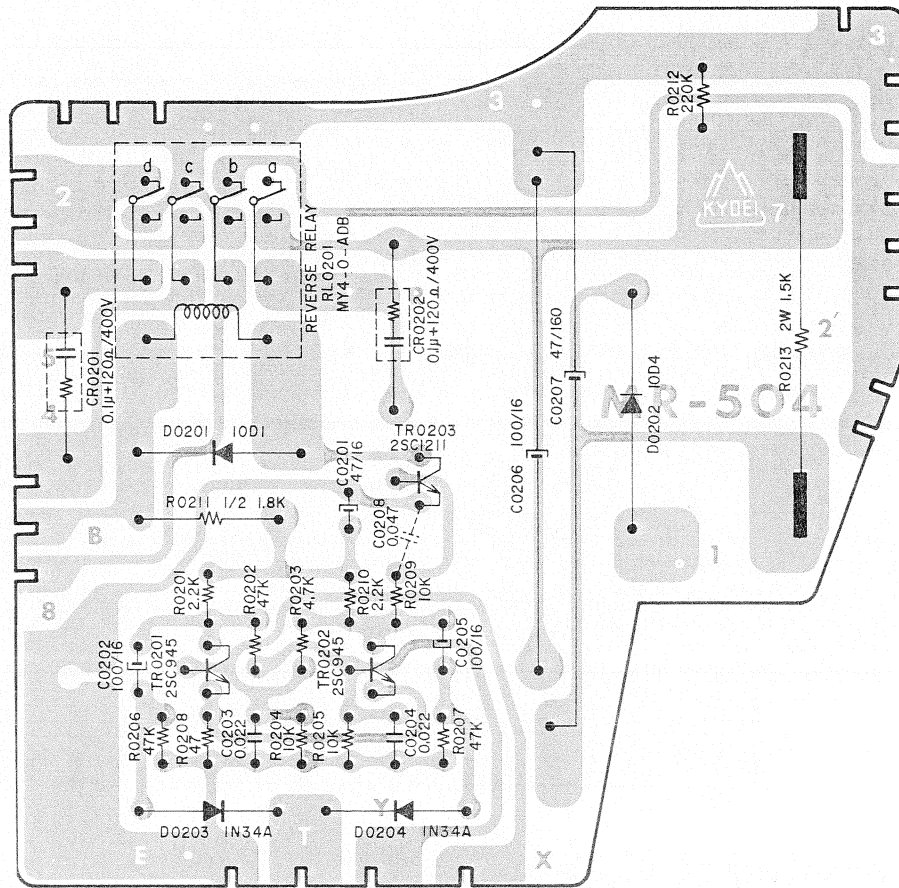

MAIN AMP. P.C. BOARD CMS-5024)

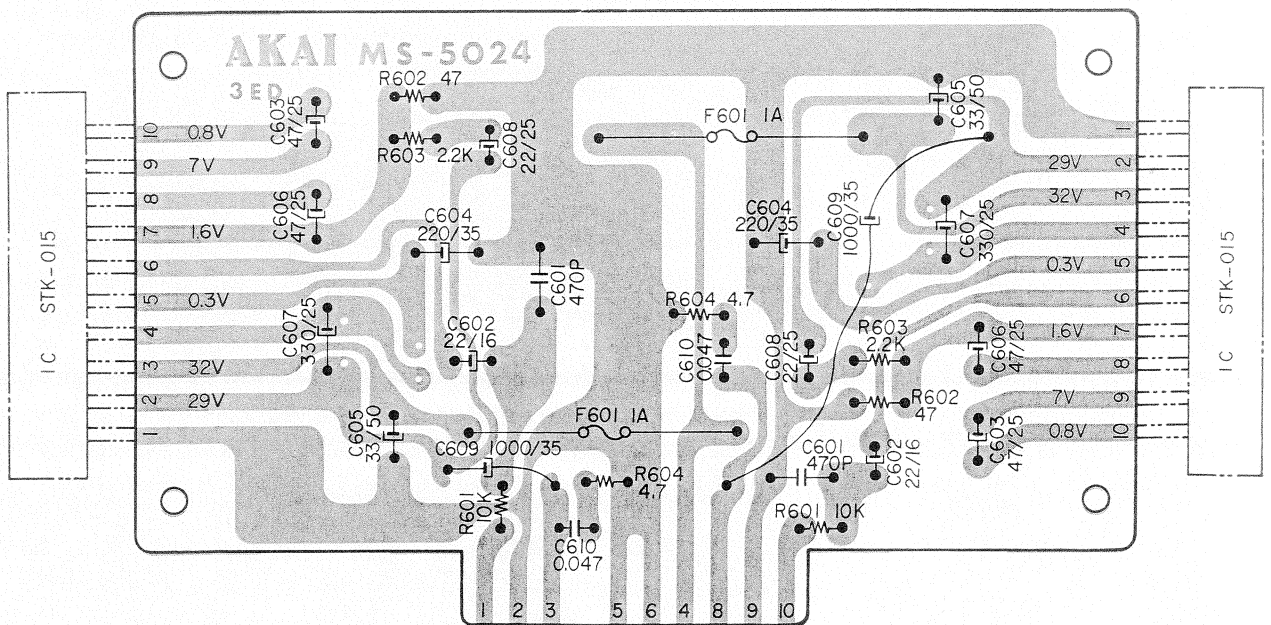

PLAYBACK AMP. P.C. BOARD (MS-5022)

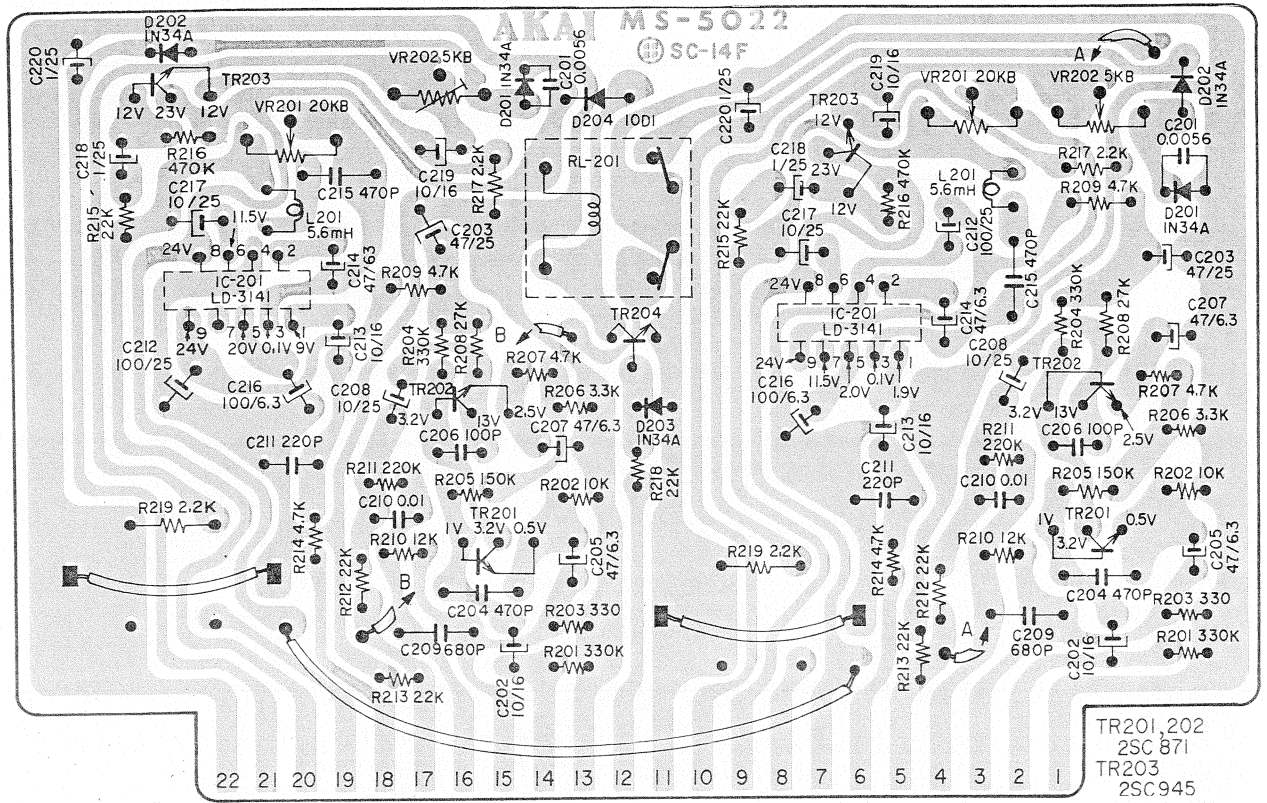

RECORDING AMP. P.C. BOARD (MS-5023)

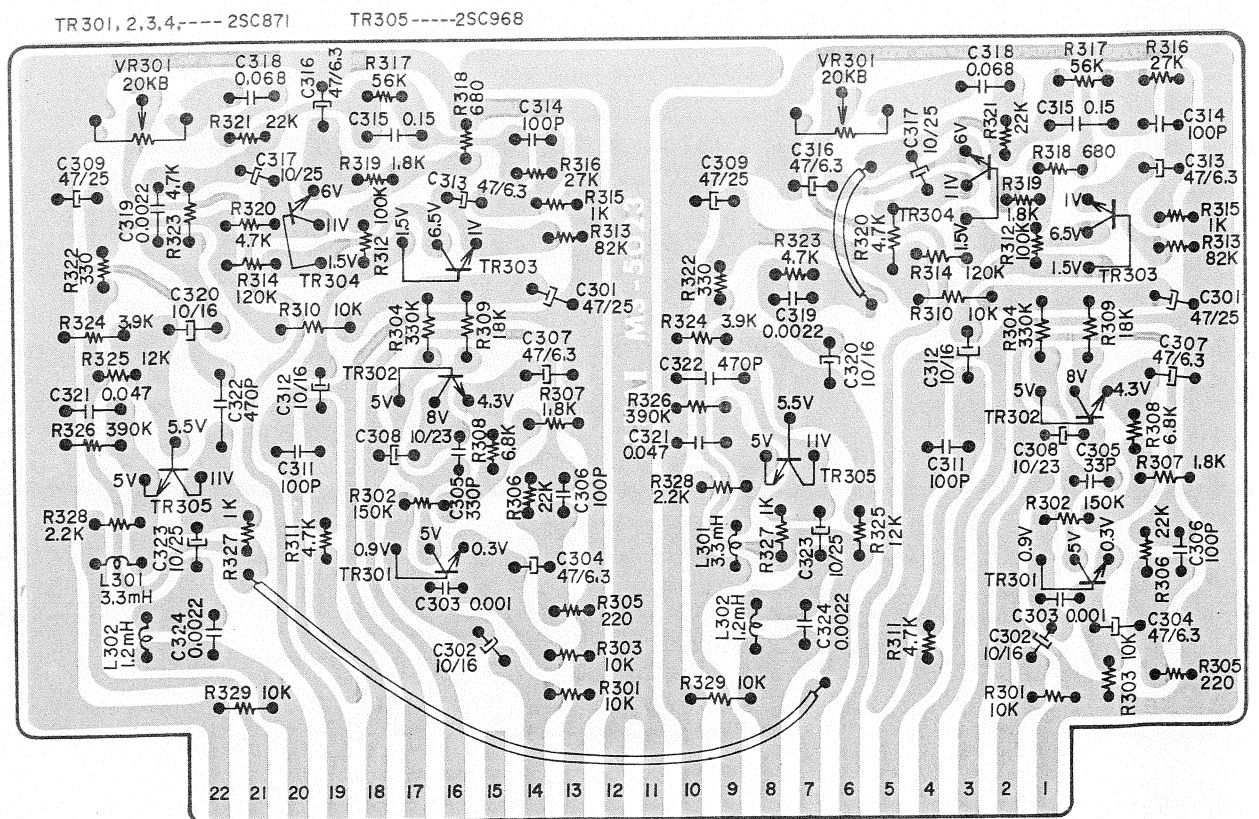

OSCILLATOR P.C. BOARD (MS-5025)

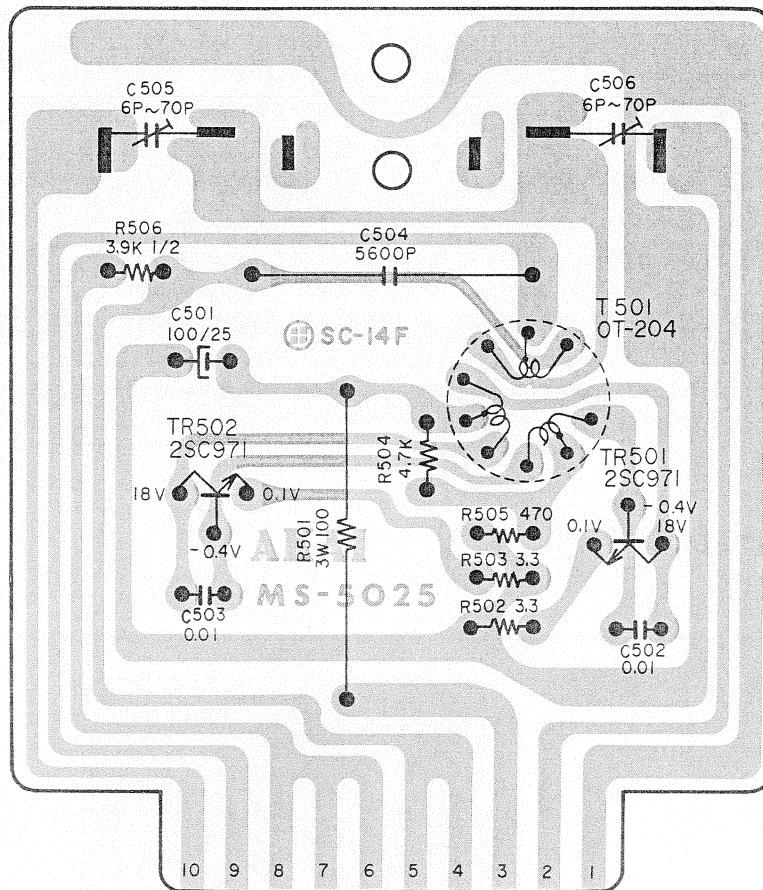

TONE CONTROL P.C. BOARD (MS-5028)

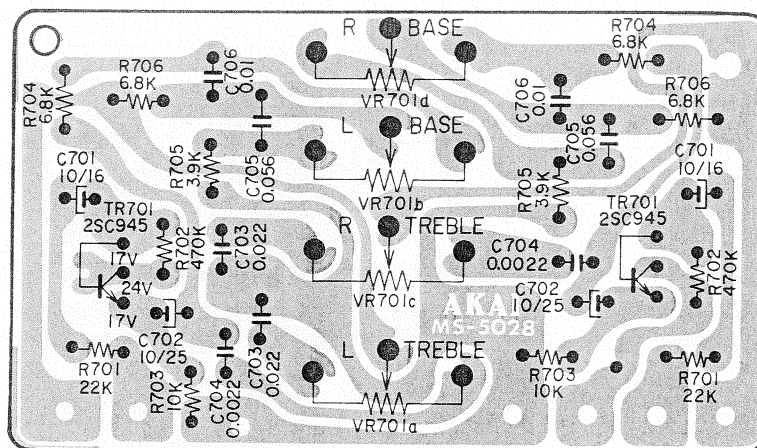

EQUALIZER P.C. BOARD (MS-5027)

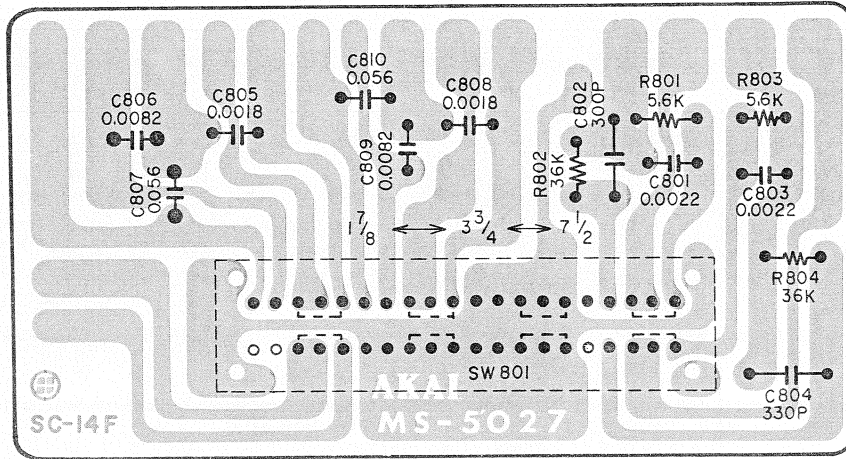

SRT. P.C. BOARD (MS-5029)

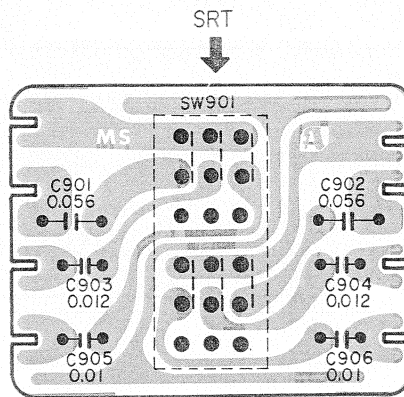

POWERSOURCE P.C. BOARD (MS-5030)

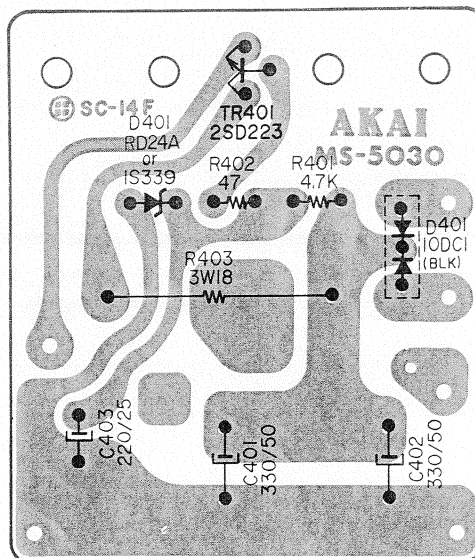

TENSION RELAY P.C. BOARD (MR-558)

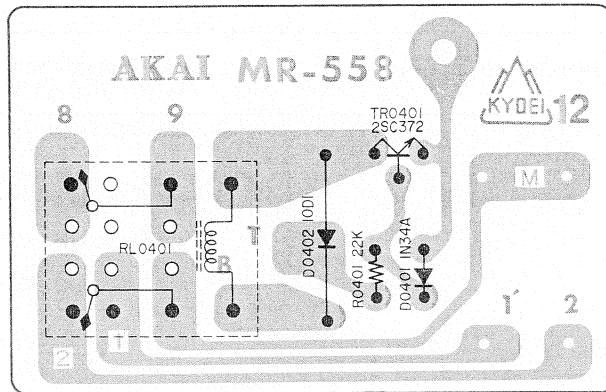

TRACK SELECTOR P.C. BOARD (MS-5026)

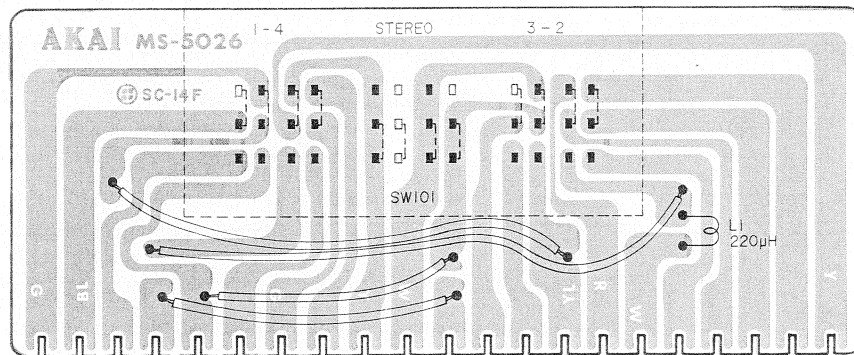

SPARK QUENCHER P.C. BOARD (MR-507)

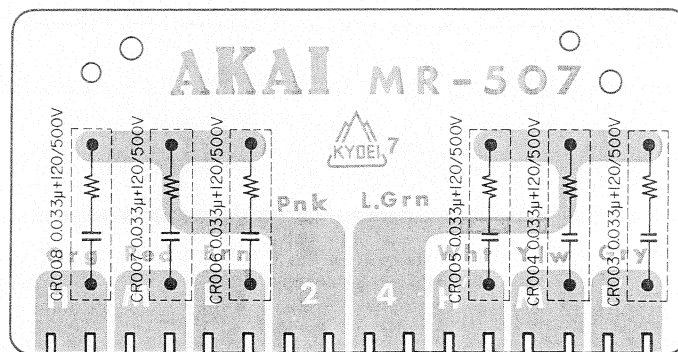

X. TROUBLE SHOOTING CHART

SECTION "A" TROUBLE WITH TAPE TRANSPORT MECHANISM

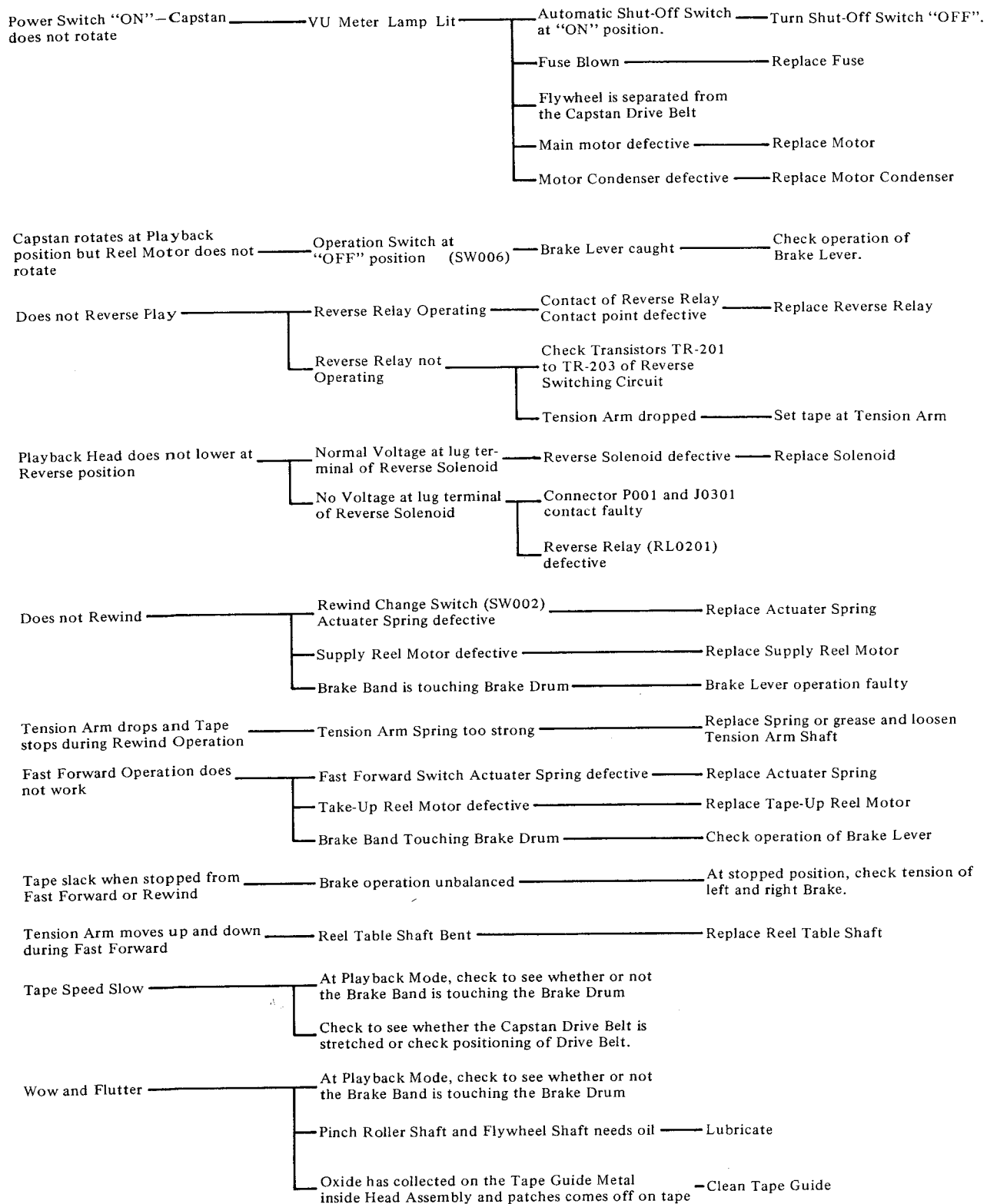

SECTION "B" TROUBLE WITH AMPLIFIER

1. Playback Mode

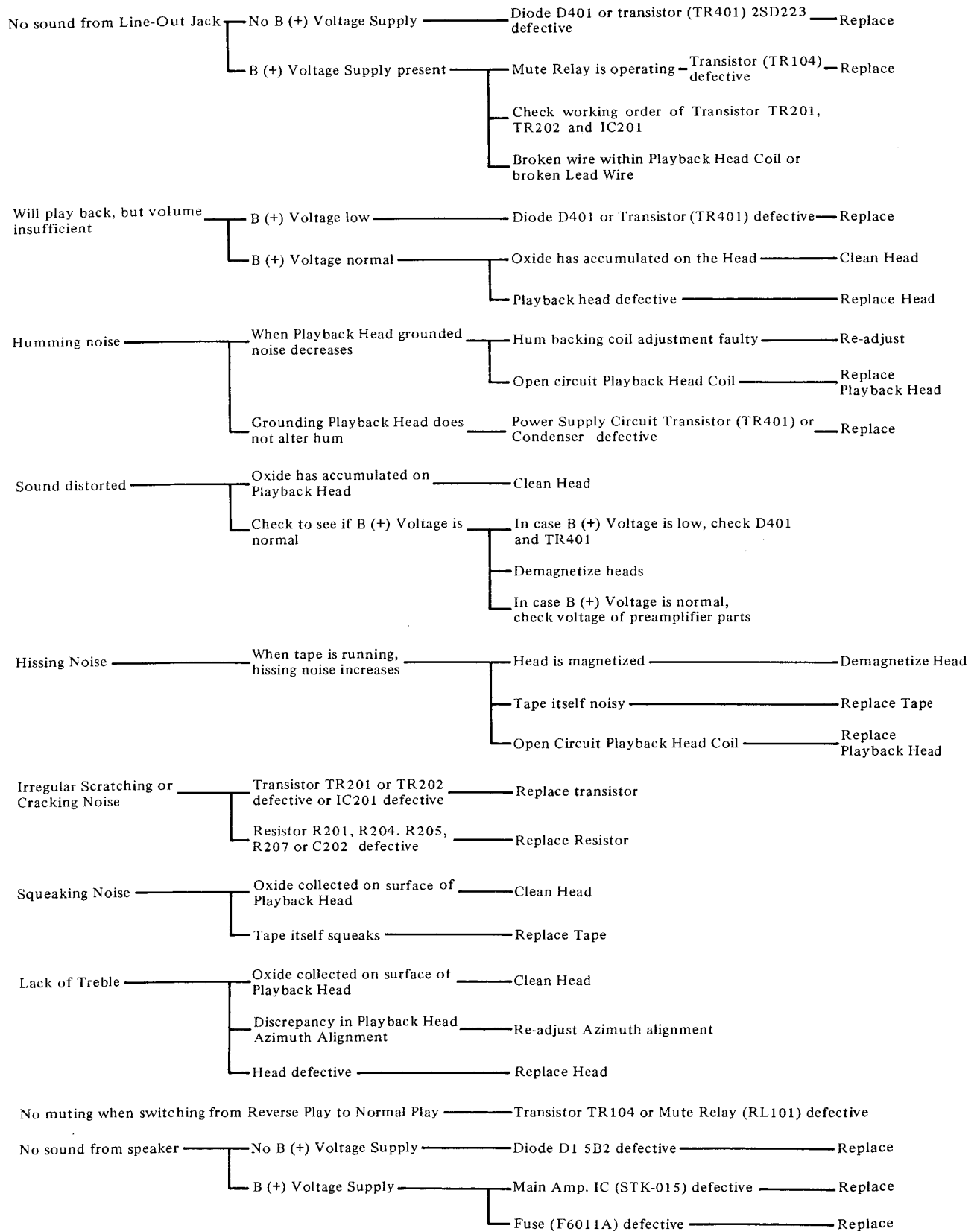

2. Recording Mode

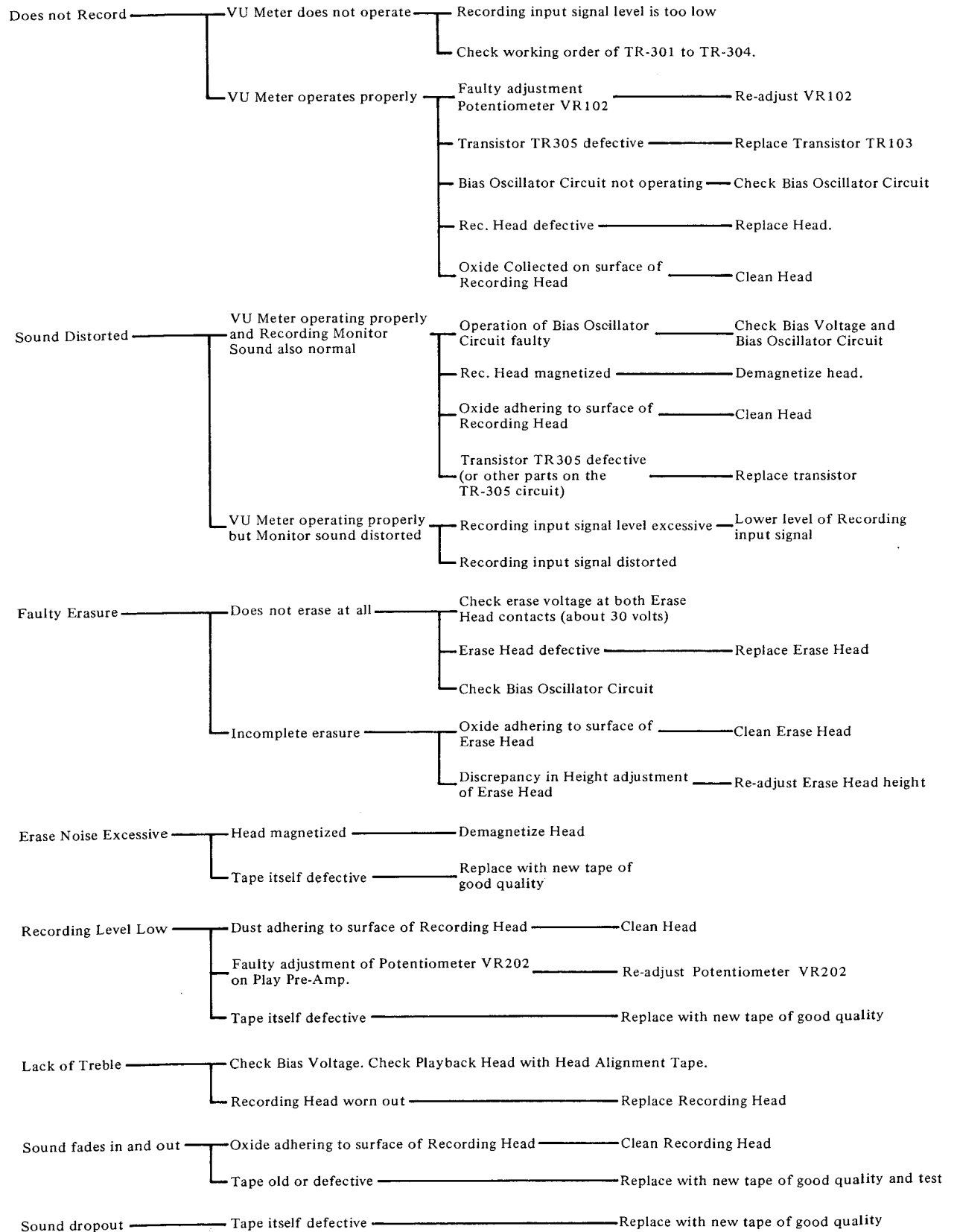

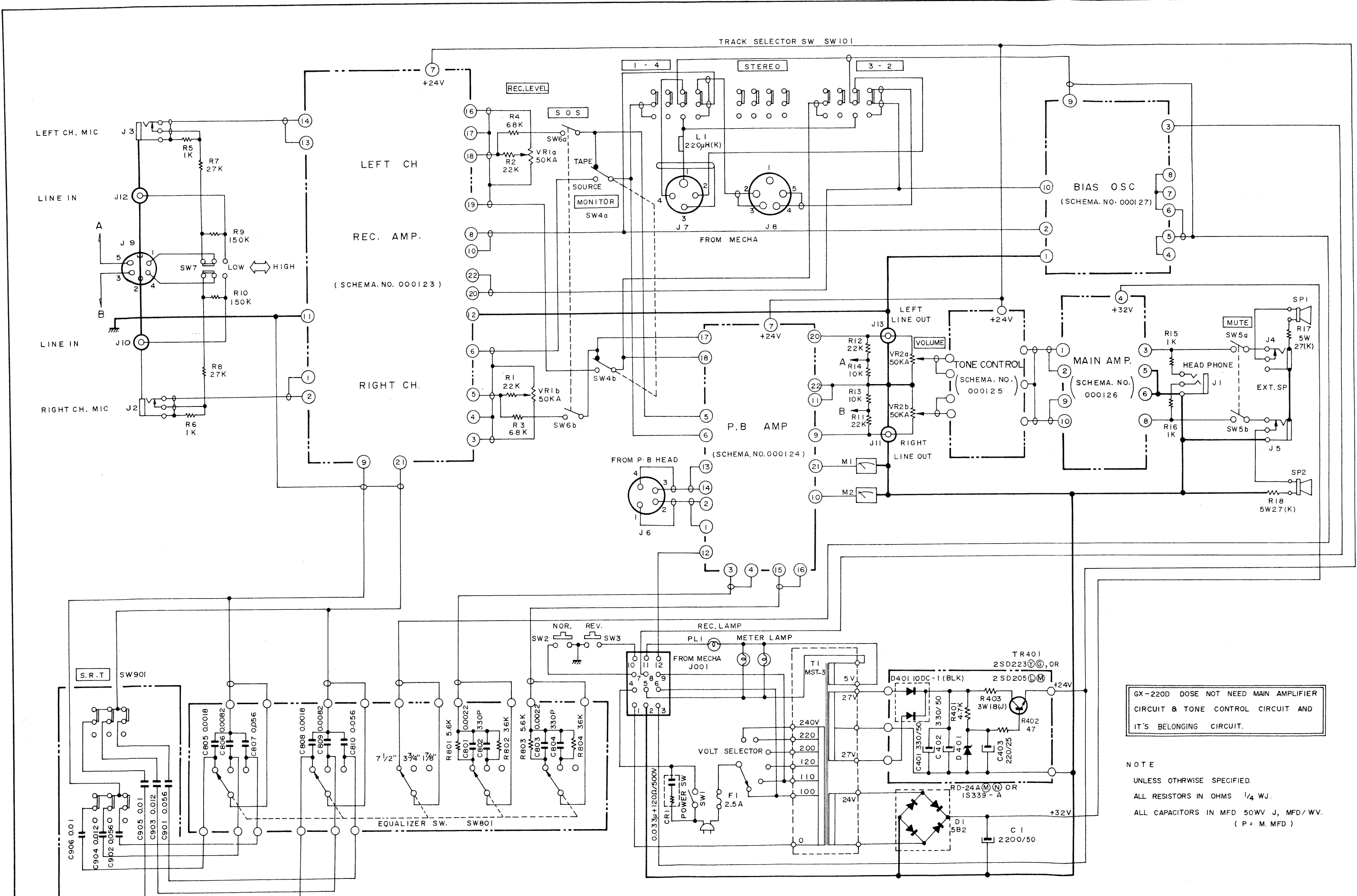

GX-220D DOES NOT NEED MAIN AMPLIFIER
CIRCUIT & TONE CONTROL CIRCUIT AND
IT'S BELONGING CIRCUIT.

NOTE
UNLESS OTHERWISE SPECIFIED.
ALL RESISTORS IN OHMS 1/4 WJ.
ALL CAPACITORS IN MFD 50WV J, MFD/WV.
(P = M. MFD)

GX-220, (D) (AMP. COMPLETE) SCHEMATIC DIAGRAM No.8-1 14206460

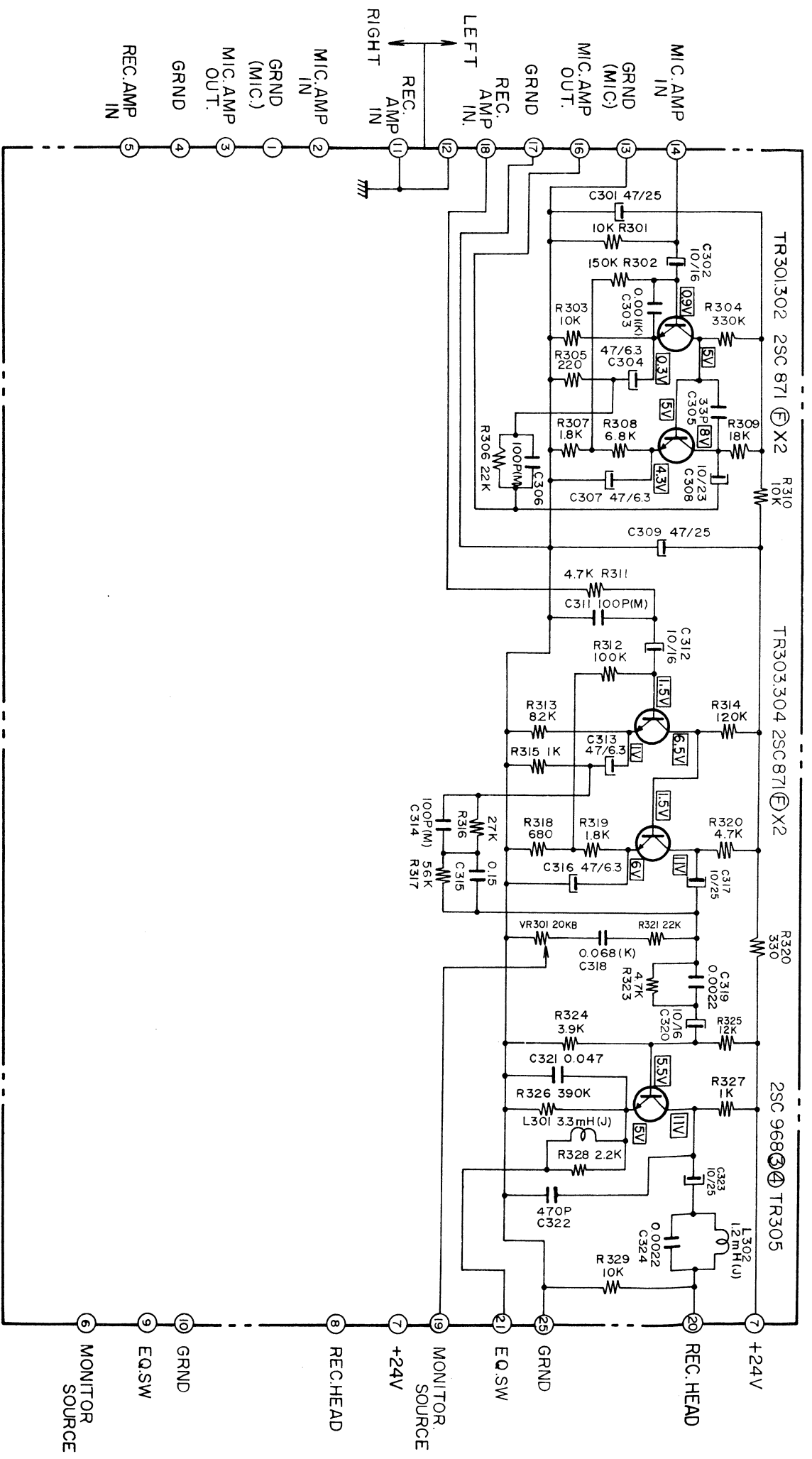

NOTE
 UNLESS OTHERWISE SPECIFIED
 ALL RESISTORS IN OHMS 1/4 WJ
 CAPACITORS IN MFD.(J) 150WV. MFD/WV
 (P=M.MFD.)

GX-220(D) (REC AMP) SCHEMATIC DIAGRAM No.8-2 14206480

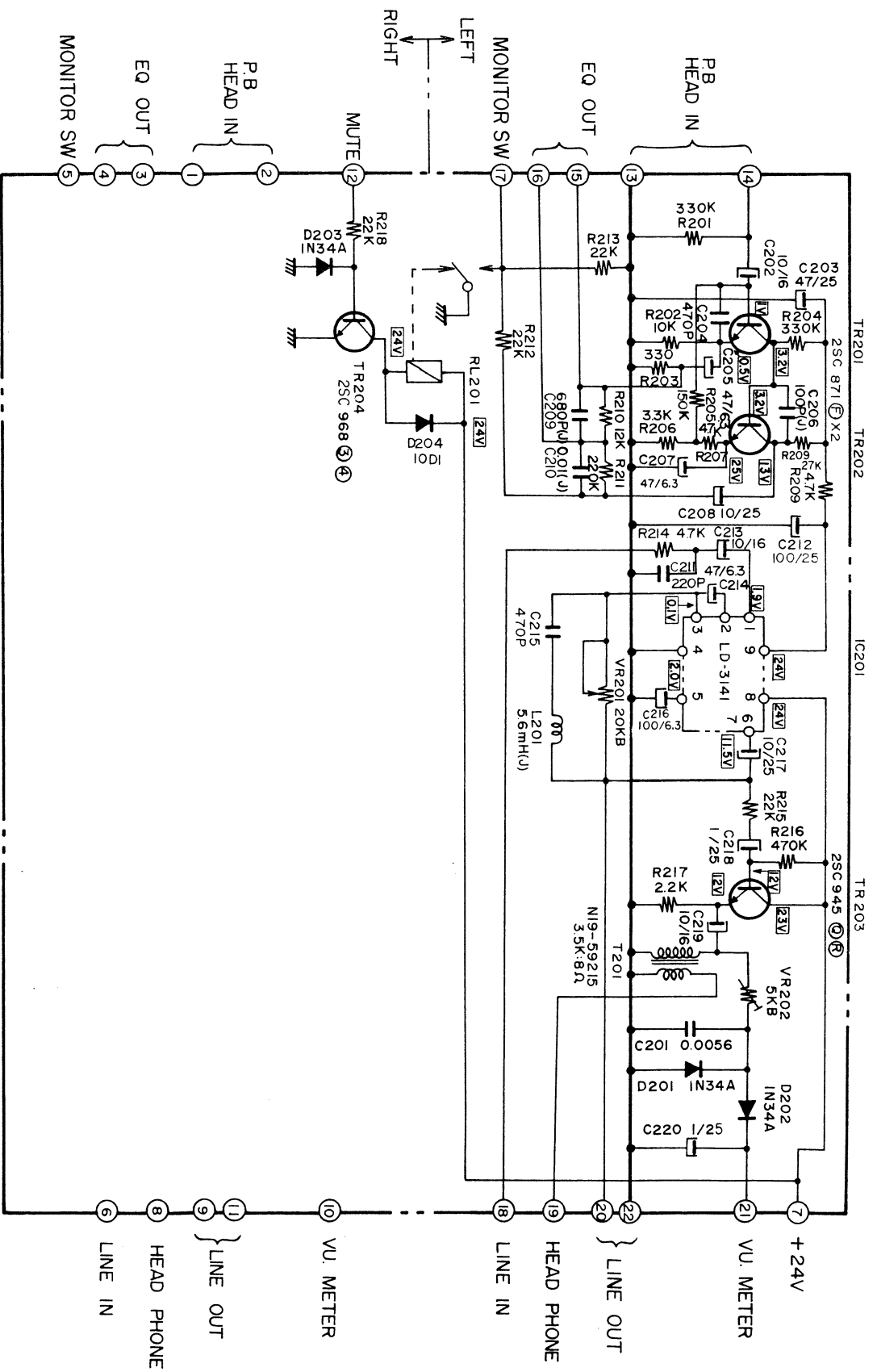

NOTE:
 UNLESS OTHERWISE SPECIFIED
 ALL RESISTORS IN OHMS 1/4 WJ
 CAPACITORS IN MFD.(K) 50WV. MFD/WV
 (P=M.MFD.)

GX-220, (D) (P. B AMP) SCHEMATIC DIAGRAM No.8-3 14206500

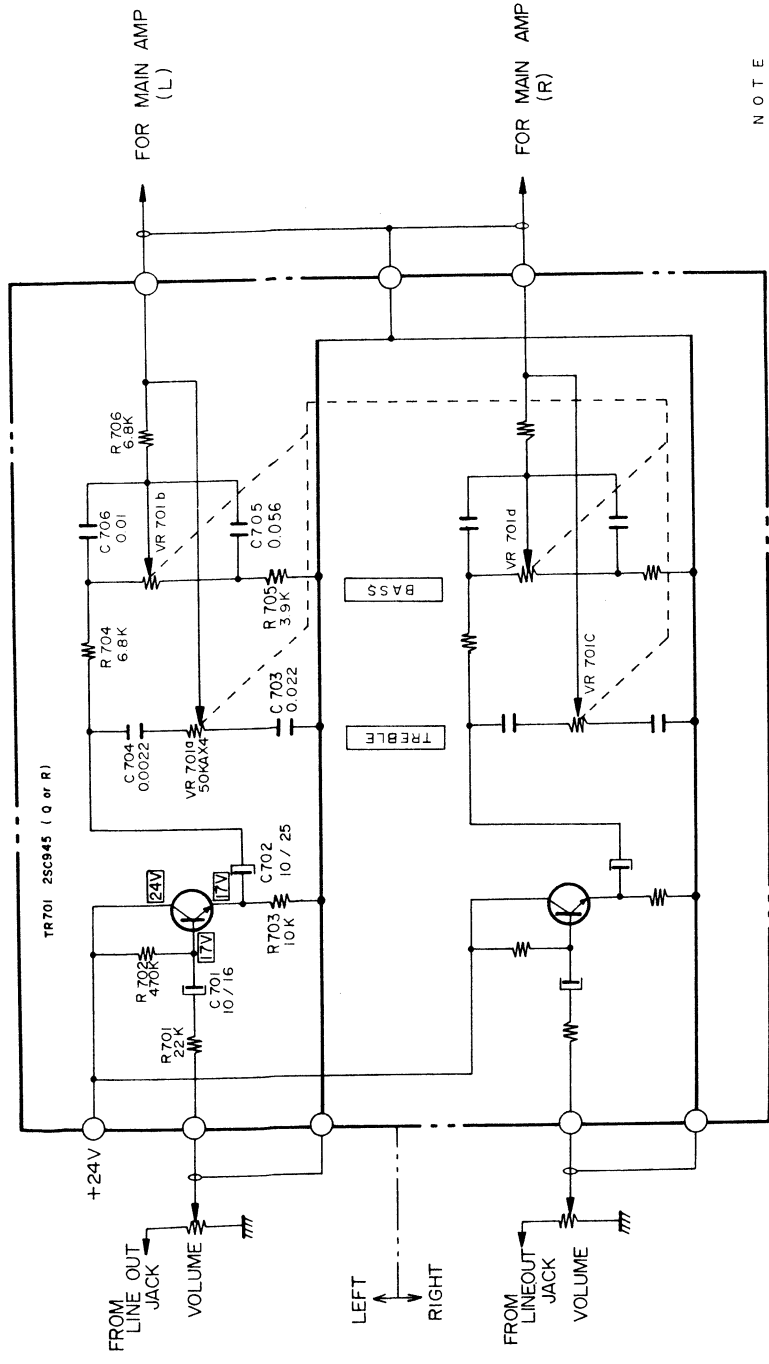

NOTE

ALL RESISTORS IN OHMS 1/4WJ

ALL CAPACITORS IN MFD(U)/50WV MFD/WV

GX-220 (TONE CONTROL) SCHEMATIC DIAGRAM No.8-4 14206520

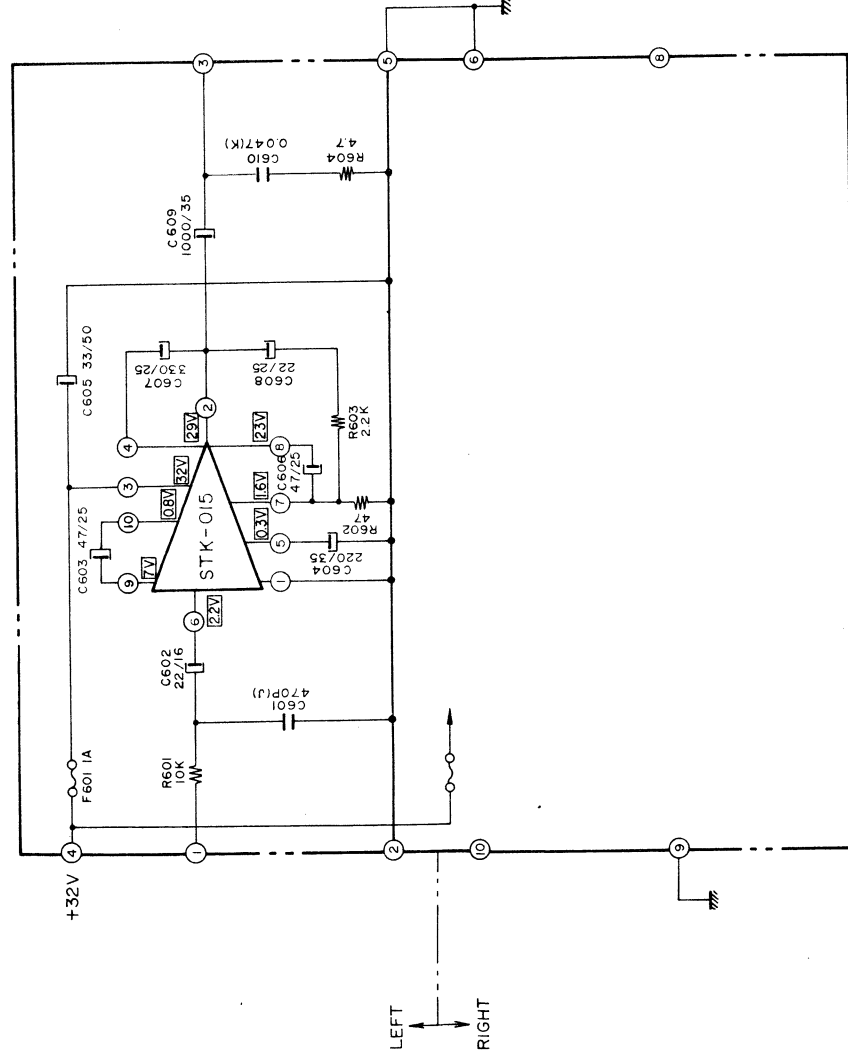

NOTE

ALL RESISTORS IN OHMS 1/4WJ

ALL CAPACITORS IN MFD(U)/50WV MFD/WV
(P=M MFD)

GX-220 (MAIN AMP) SCHEMATIC DIAGRAM No.8-5 14206540

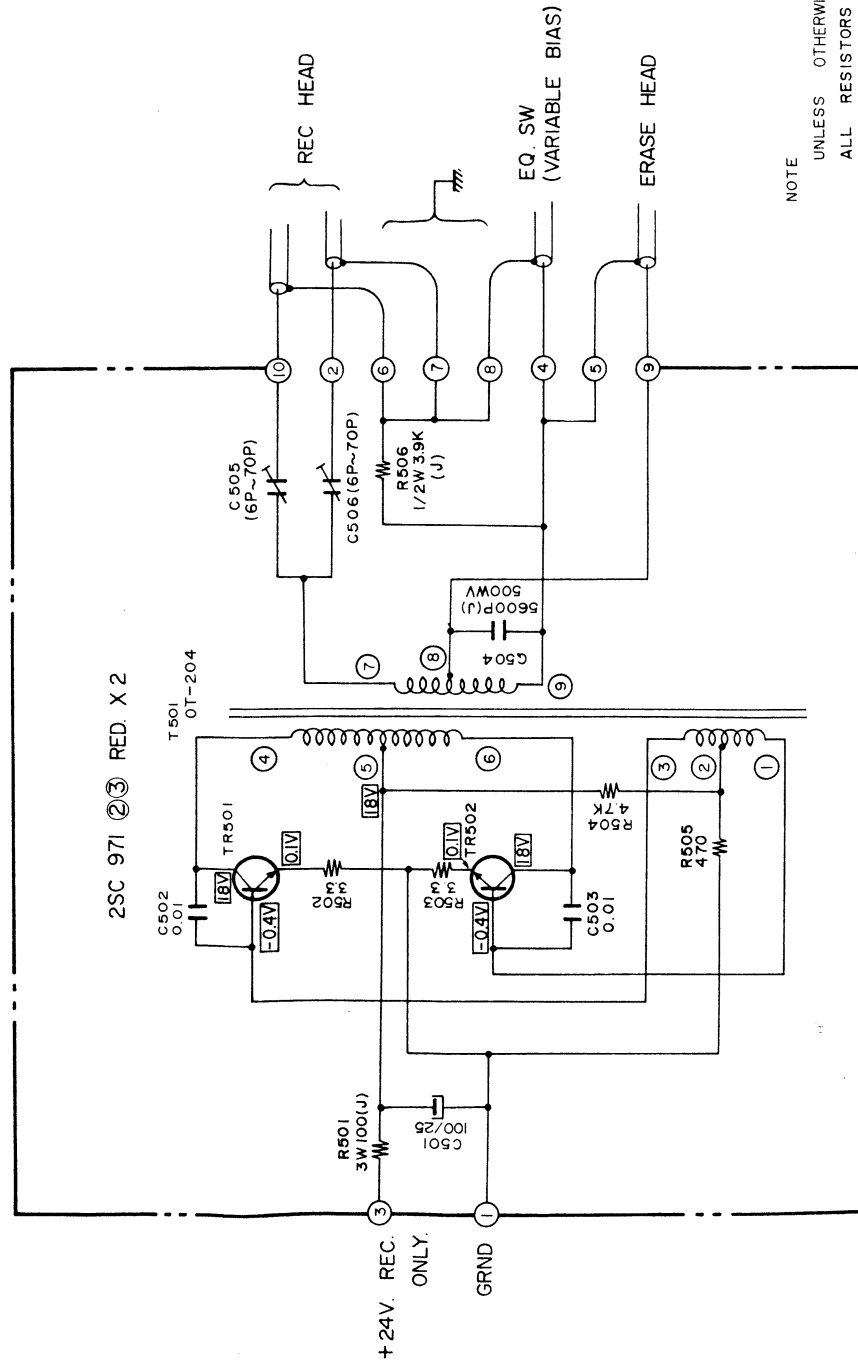

NOTE

UNLESS OTHERWISE SPECIFIED

ALL RESISTORS IN OHMS 1/4WJ

ALL CAPACITORS IN MFD(U)/50WV MFD/WV
(P=M MFD)

GX-220, (D) (BIAS O.S.C.) SCHEMATIC DIAGRAM. No.8-6 14206560

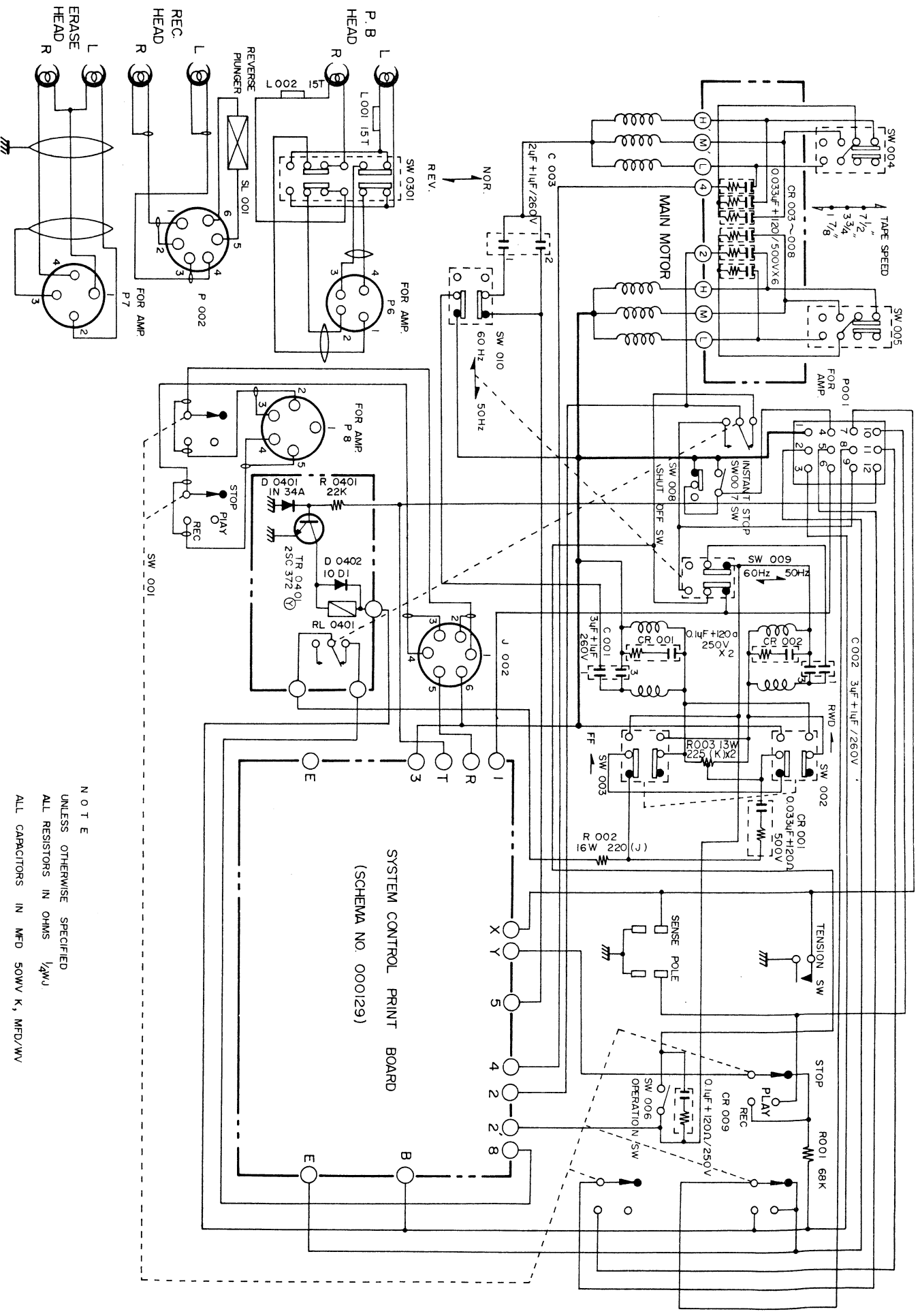

NOTE
UNLESS OTHERWISE SPECIFIED
ALL RESISTORS IN OHMS 1/4W
ALL CAPACITORS IN MFD 50WV K, MFD/WV

GX-220.(D) (MECHANISM) SCHEMATIC DIAGRAM No.8-7 14203580

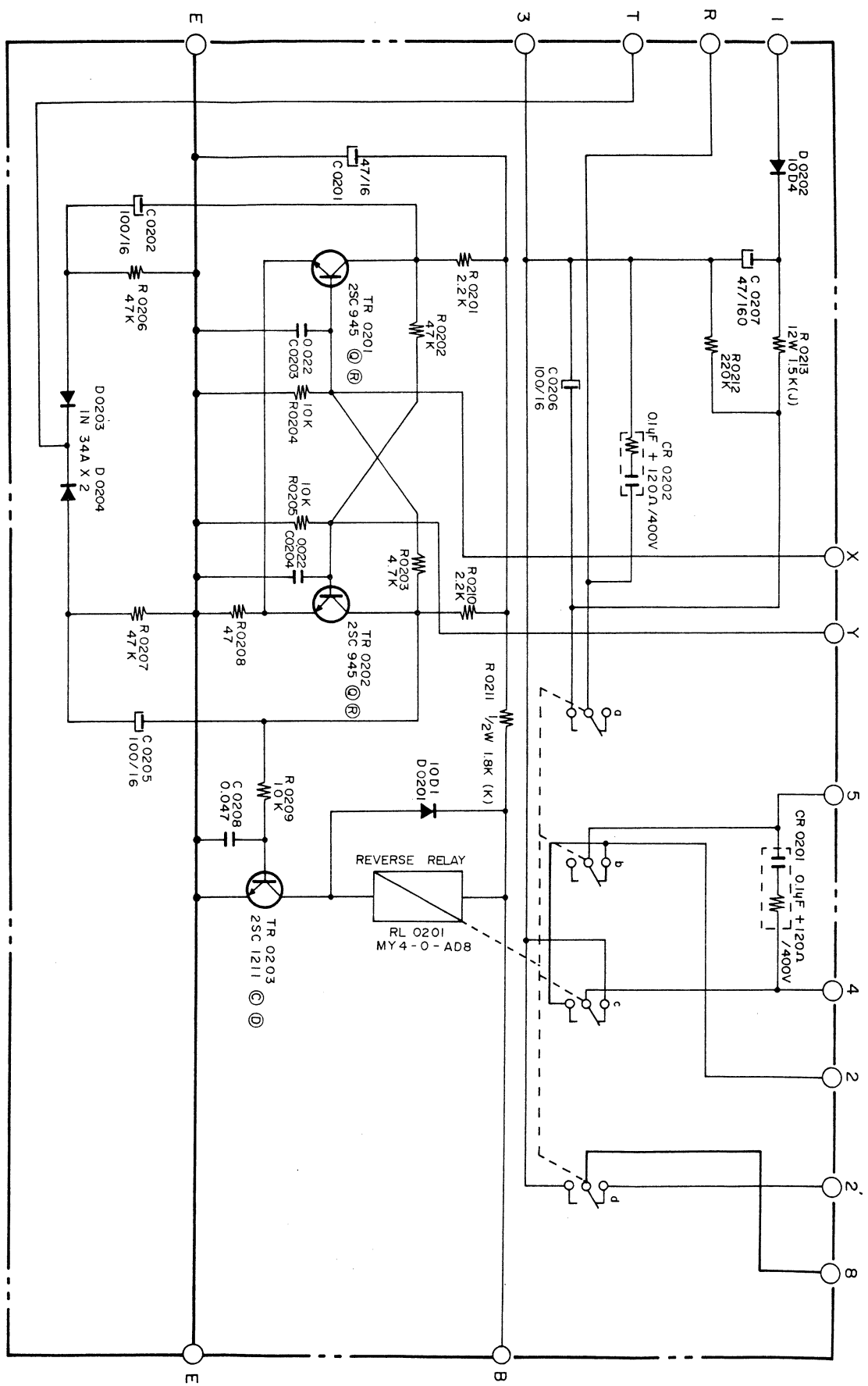

NOTE
UNLESS OTHERWISE SPECIFIED.
ALL RESISTORS IN OHMS 1/4 W J.
ALL CAPACITORS IN MFD 50WV K, MFD/WV
(P = M. MFD)

GX-220, (D) (SYSTEM CONTROL) SCHEMATIC DIAGRAM No.8-8 14206600