

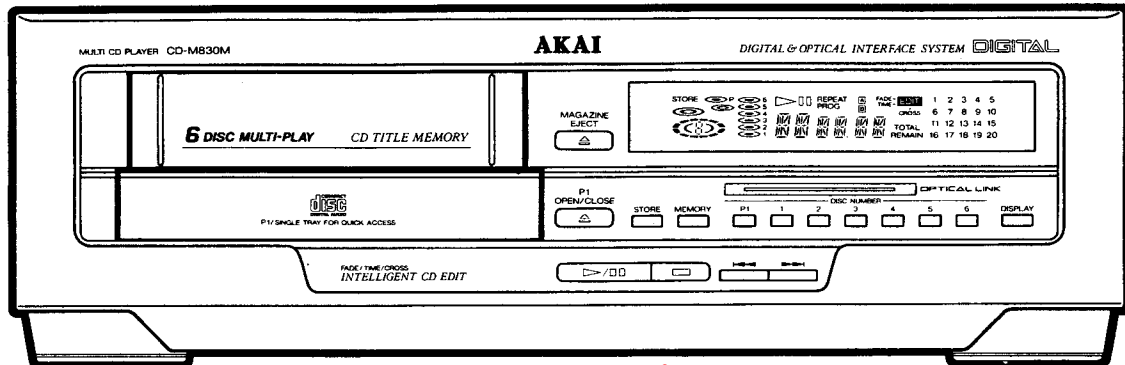

V04954

AK 08

AKAI SERVICE MANUAL



RTV servis Horvat

Kešinci, 31402 Semeljci

031-856-139

031-856-637

098-788-319

rtv-servis-horvat@os.tel.hr

Croatia

MULTI COMPACT DISC PLAYER

MODEL CD-M830M

SPECIFICATIONS

Type	7 disk auto changer
Pick-up system	3 beam laser pick-up
Error correction system	Cross interleave reed solomon
Number of channels	2 channel stereo
Wow & flutter	Less than measurable limits
Optical output level	- 22·dBs / 660 nm
Power requirements	Supplied from amplifier (model AX-M430 / AM-M630 / AM-M830)
Dimensions	360 (W) X 117 (H) X 315 (D) mm
Weights	3.8 kg
Standard accessories	
Optical cable	X1
Disc magazine (MCD-12)	X1
Operator's manual	X1

* For improvement purposes, specifications and design are subject to change without notice.

0 dBs = 0.775 V

★ SAFETY INSTRUCTIONS

PRECAUTIONS DURING SERVICING

1. Parts identified by the \triangle (*) symbol are critical for safety. Replace only with parts number specified.
2. In addition to safety, other parts and assemblies are specified for conformance with such regulations as those applying to spurious radiation.
These must also be replaced only with specified replacements.
Examples: RF converters, tuner units, antenna selector switches, RF cables, noise blocking capacitors, noise blocking filters, etc.
3. Use specified internal wiring. Note especially:
 - 1) Wires covered with PVC tubing
 - 2) Double insulated wires
 - 3) High voltage leads
4. Use specified insulating materials for hazardous live parts. Note especially:
 - 1) Insulation Tape
 - 2) PVC tubing
 - 3) Spacers (Insulating barriers)
 - 4) Insulation sheets for transistors
 - 5) Plastic screws for fixing microswitch (especially in turntable)
5. When replacing AC primary side components (transformers, power cords, noise blocking capacitors, etc.), wrap ends of wires securely about the terminals before soldering.

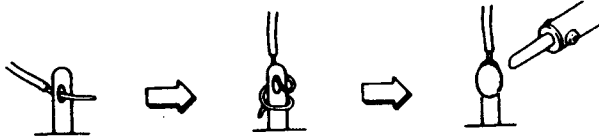

6. Observe that wires do not contact heat producing parts (heatsinks, oxide metal film resistors, fusible resistors, etc.).
7. Check that replaced wires do not contact sharp edged or pointed parts.
8. Also check areas surrounding repaired locations.
9. Use care that foreign objects (screws, solder droplets, etc.) do not remain inside the set.

SAFETY CHECK AFTER SERVICING

After servicing, make measurements of leakage-current or resistance in order to determine that exposed parts are acceptably insulated from the supply circuit.

The leakage-current measurement should be done between accessible metal parts (such as chassis, ground terminal, microphone jacks, signal input/output connectors, etc.) and the earth ground through a resistor of 1500 ohms paralleled with a 0.15 μ F capacitor, under the unit's normal working conditions. The leakage-current should be less than 0.5 mA rms AC.

The resistance measurement should be done between accessible exposed metal parts and power cord plug prongs with the power switch (if included) "ON". The resistance should be more than 2.2 Mohms.

MAKE YOUR CONTRIBUTION TO PROTECT THE ENVIRONMENT

Used batteries with the ISO symbol for recycling as well as small accumulators (rechargeable batteries), mini-batteries (cells) and starter batteries should not be thrown into the garbage can.



Please leave them at an appropriate depot. All other household batteries can be thrown out with the household waste.

★ INFORMATION

SYMBOLS FOR PRIMARY DESTINATION

Primary destination of units are indicated with the following alphabet.

Symbols	Principal Destinations
B	UK
E	Europe (except UK)
S	Australia
V	Germany
U	Universal Area
Y*	Custom version

CLASS 1 LASER PRODUCT

This product contains a low power laser device. To ensure continued safety, do not remove any covers or attempt to gain access to the inside of the product. Refer any servicing to qualified personal. Use actual size stickers.

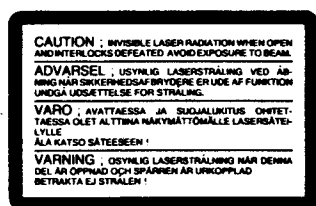
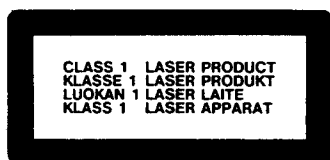

PRECAUTIONS IN REPAIRING

When repairing or adjusting the unit, please note the following points.

1. Do not put excessiv pressure on the mechanical part (operation part), including the pick-up block, as extremely high mechanical precision is required in these parts.
2. When the base is removed for repair or adjustment, make sure that there are no metal objects in the narrow gap between the P.C.board or the mecha parts and the base.
3. The Micro-Computer and the CD signal processing ICs can be damaged by static electricity or leakage from a soldering iron during repairing. While soldering, please take the precautions against leakage as in the illustration.

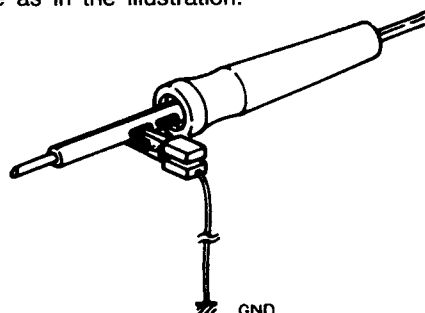

4. Do not loosen any screws in the pick-up block. When handing the pick-up block, please refer to the points to NOTE when replacing the pick-up block.
5. Keep safety for hazardous invisible Laser Radiation, DO NOT watch the Laser Beam (Objective lens) directly.
6. Models for the some countries, laser warning labels are affixed on the unit and inside of the unit, as shown below. Read it carefully for your safety, when repairing or adjusting the unit.

PRECAUTIONS BEFORE/AFTER REPAIRING THE UNIT

[ABOUT THE POWER SUPPLY]

Power supply and power control data for the CD-M830M are supplied from the amplifier and tuner. Therefore, when repair of the CD-M830M is necessary, repair should be made together with the amplifier and tuner. To repair the CD-M830M without the tuner, ripair it together with the amplifier, using the following procedure.

* When amplifier is AM-M630/AM-M830

- 1) While pressing the ▷▷ and ◁◁ button of the CD-M830M, connect the AC power cord of the amplifier to the AC power outlet.
- 2) While pressing the G.E.REC button, press the POWER button of the amplifier to turn the power of the AM-M630/AM-M830 and CD-M830M on.
- 3) To turn off the power of the amplifier and CD-M830M, the AC cord must be disconnected.

* When amplifier is AX-M430

- 1) While pressing the ▷▷ and ◁◁ button of the CD-M830M, connect the AC power cord of the amplifier to the AC power outlet.
- 2) While pressing the PLAY (▷) button, press the POWER button of the amplifier to turn the power of the AX-M430 and CD-M830M on.
- 3) To turn off the power of the amplifier and CD-M830M, the AC cord must be disconnected.

I. DISASSEMBLY

In case of trouble, etc., necessitating dismantling, please dismantle in the order shown in the illustrations. Reassemble in reverse order

1. Removal of UPPER COVER

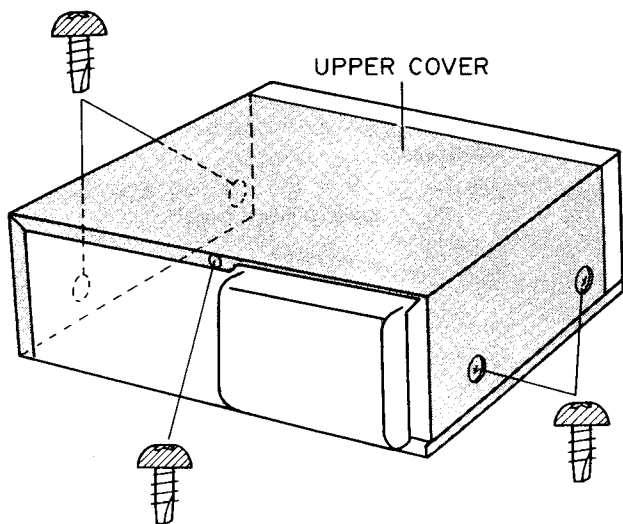

2. Removal of FRONT PANEL

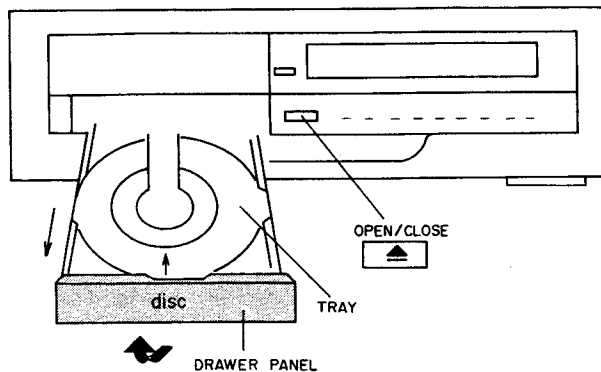

- 1) Turn the power on.
- 2) Press the OPEN/CLOSE (\cong) button to open the disc drawer.
- 3) While pressing the tray in a little, pull the middle section of the drawer panel forward and upward to remove it.
- 4) With the disc drawer in the open position, remove the FRONT PANEL retaining screws and remove the PANEL.
- 5) Press the OPEN/CLOSE (\cong) button to close the disc drawer.
- 6) Turn the power off.

Release the Hooks

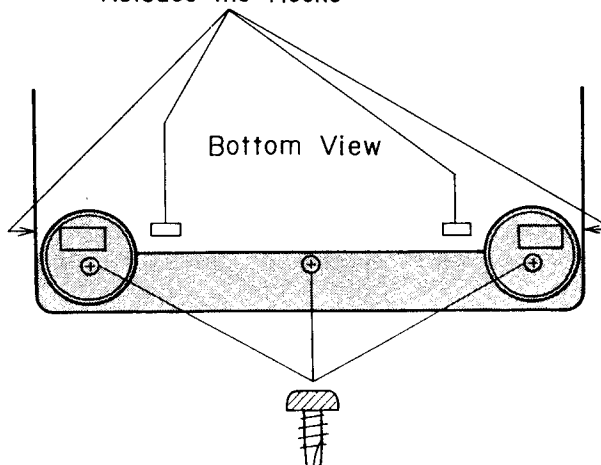

II. PRINCIPAL PARTS LOCATION

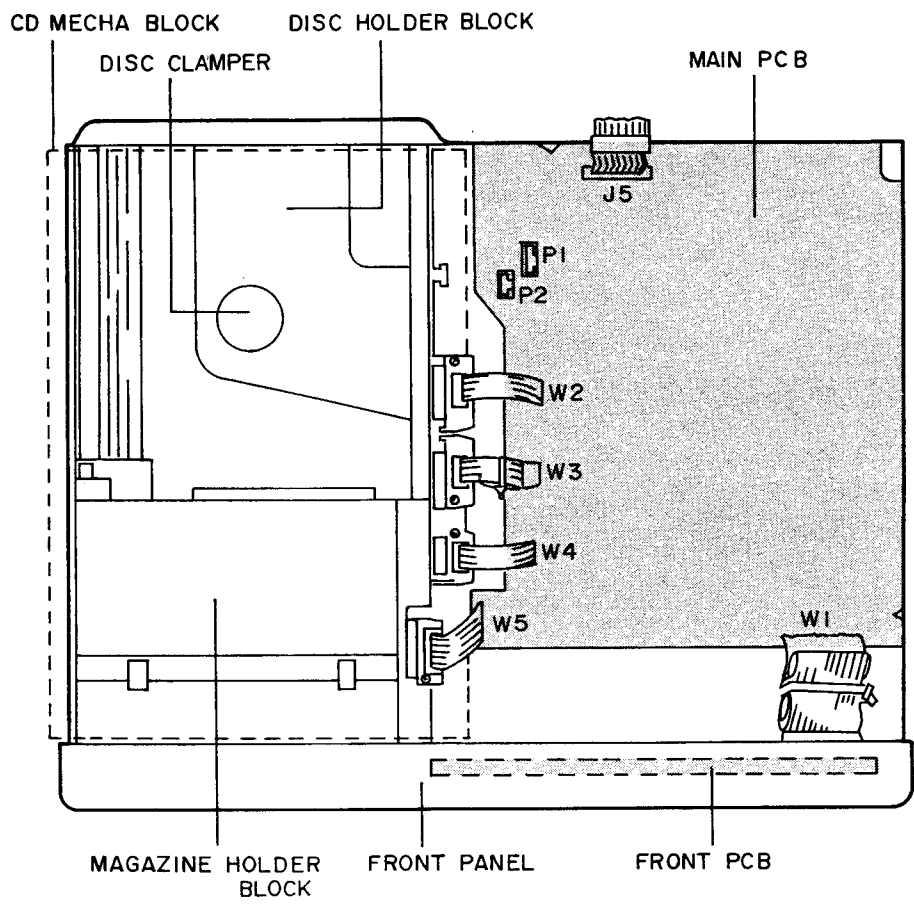

Fig.2-1 Top view

CD MECHA BLOCK

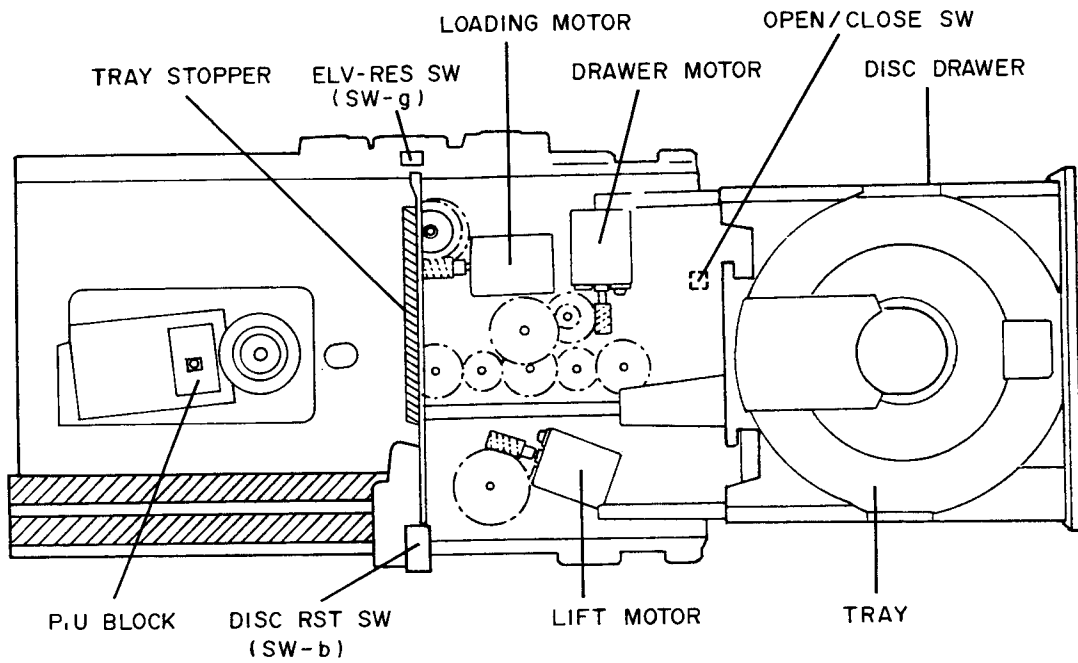

Fig.2-2 Top view

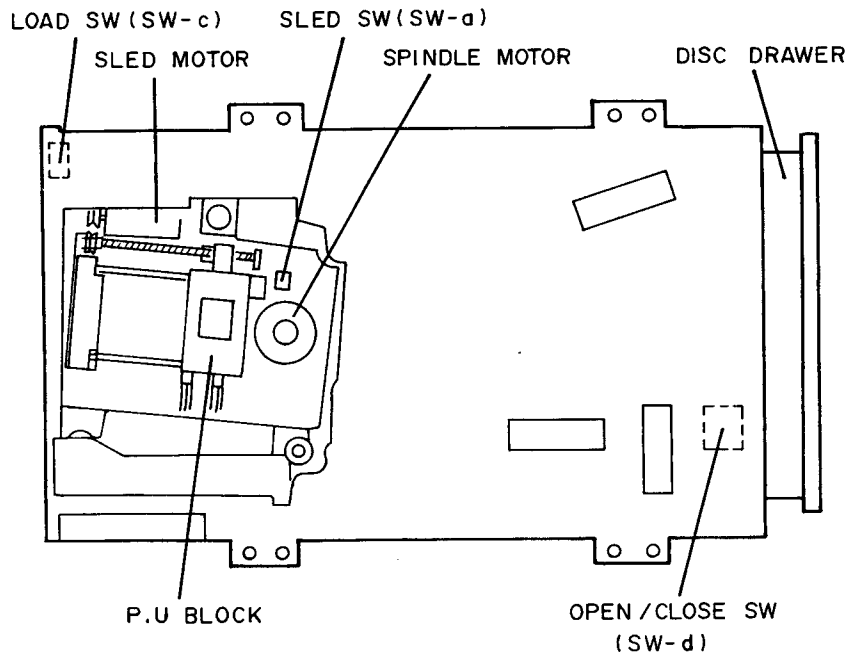
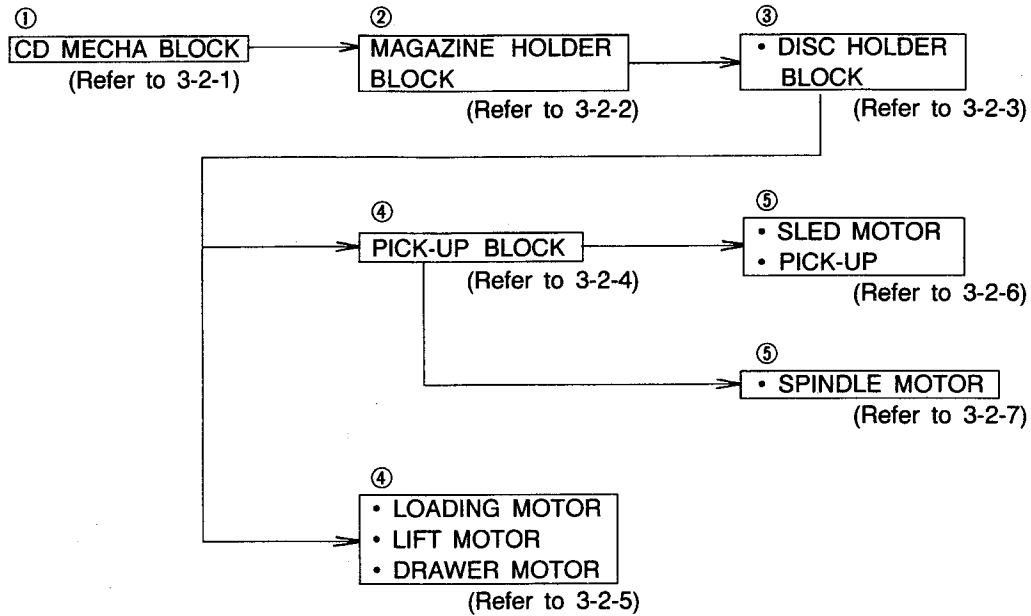

Fig.2-3 Bottom view

III. REPLACEMENT OF PRINCIPAL COMPONENTS

3-1. DISMANTLING PROCEDURE OF THE COMPONENTS

• When replacement of mechanical parts is necessary, replace the parts using the following procedure.



3-2. DISMANTLING METHOD OF EACH COMPONENT

3-2-1. HOW TO REMOVE THE CD MECHA BLOCK

- 1) Remove the P1 and P2 connectors on the MAIN PCB.
- 2) Remove the W2, W3, W4 and W5 connectors on the MECHA BLOCK.
- 3) Remove the mecha block retaining screws (A) and (B).

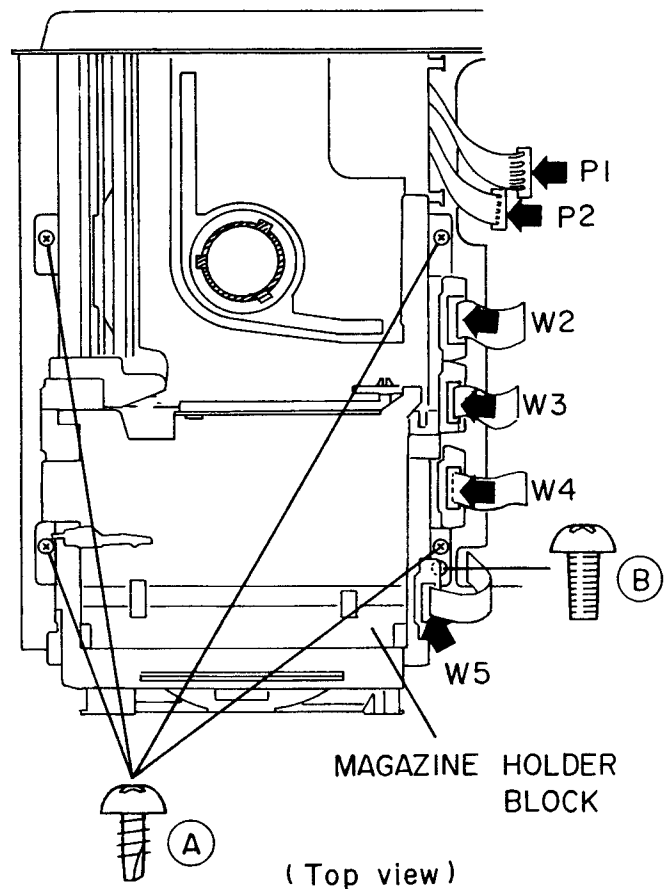

Fig.3-1

3-2-2. HOW TO REMOVE THE MAGAZINE HOLDER BLOCK

- 1) Remove the magazine holder block retaining screws ③.
- 2) Move the magazine holder block forward and disengage the 4 retaining tabs to remove it.
- 3) Remove the tray stopper.

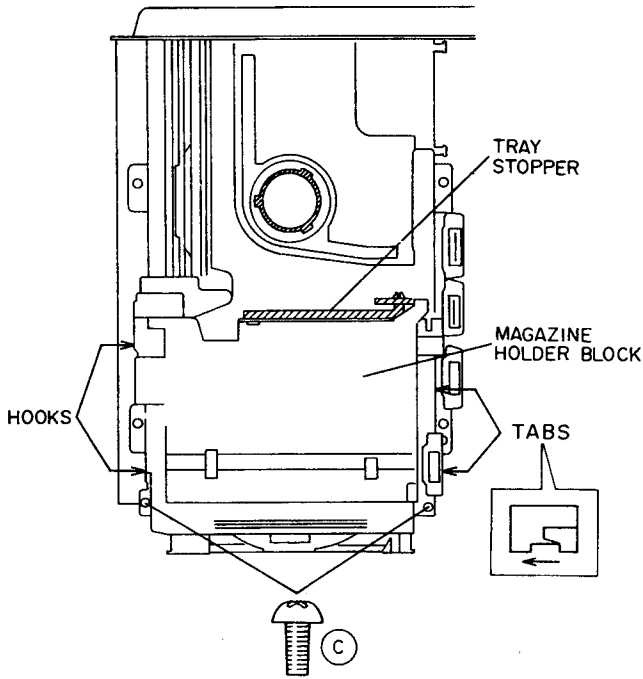

Fig 3-2

3-2-3. HOW TO REMOVE THE DISC HOLDER BLOCK

- 1) Remove the disc holder retaining screws ④ and ⑤.
- 2) Disengage the disc holder's 4 retaining tabs to remove it.

Caution

- * When tightening the screw ⑤, adjust the space between the clamper and mg holder bracket to 1.2 to 1.8 mm.
- * If the screw ⑤ is tightened too tightly, the clamper and disc holder will touch causing poor revolution.
- * Paint lock the screw ⑤.

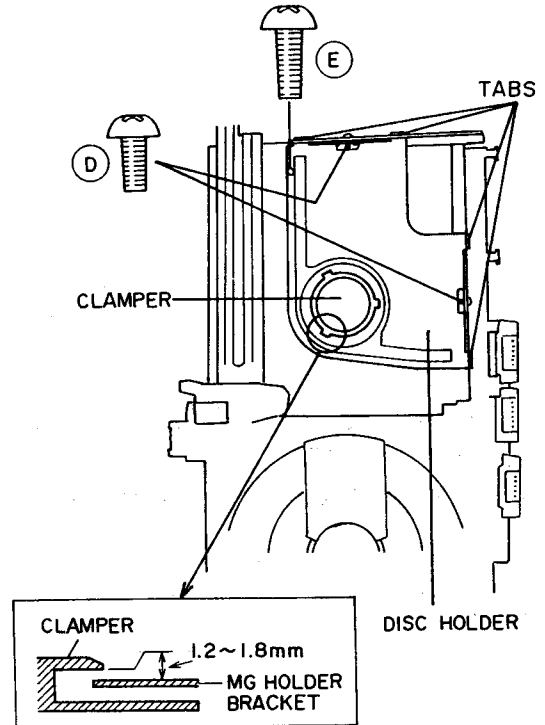

Fig 3-3

3-2-4. HOW TO REMOVE THE PICK-UP BLOCK

- 1) Turn the CD mecha block over.
- 2) Remove the wire protector.
- 3) Remove the pick-up block retaining screws (F) and spring.
- 4) Remove the pick-up block from the CD mecha block.

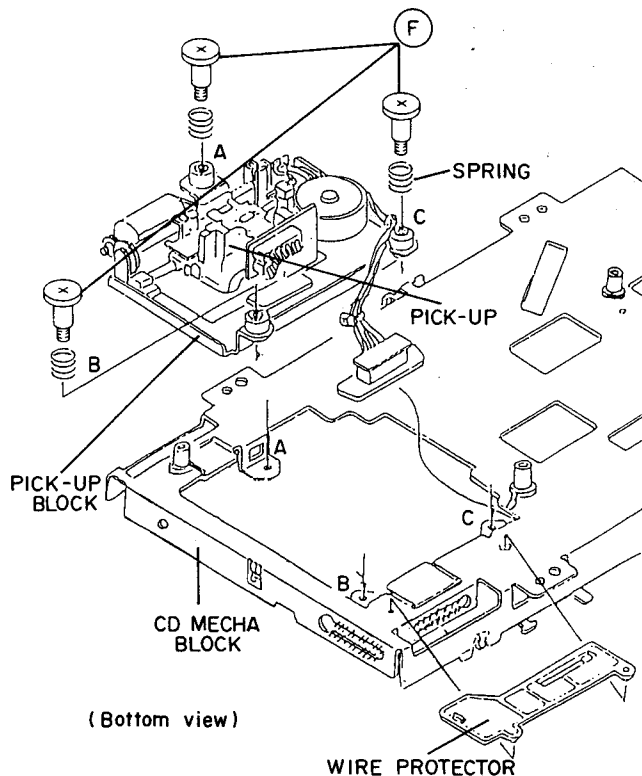

Fig.3-4

3-2-5. HOW TO REMOVE THE LOADING MOTOR, LIFT MOTOR AND DRAWER MOTOR

- 1) Turn the GEAR B (located in the disc drawer's middle hole) counterclockwise for 2 or 3 revolutions to move the drawer slightly forward and release the lock.
- 2) Use your hands to slowly pull out the disc drawer.
- 3) Remove the mounting screws of each motor.

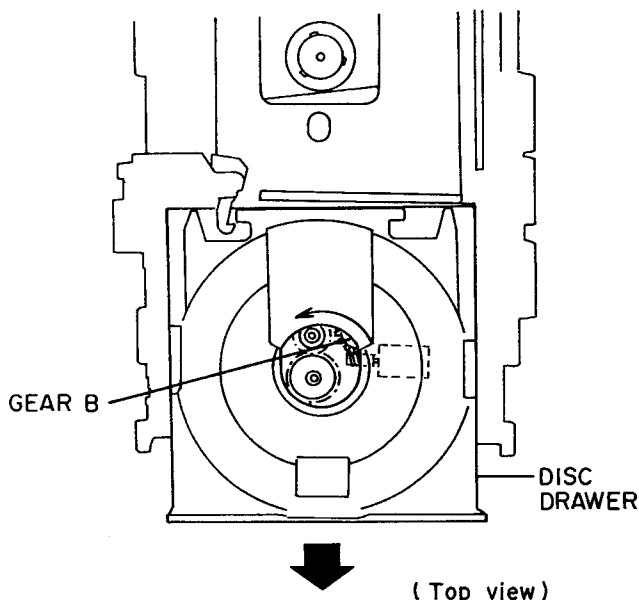

Fig.3-5

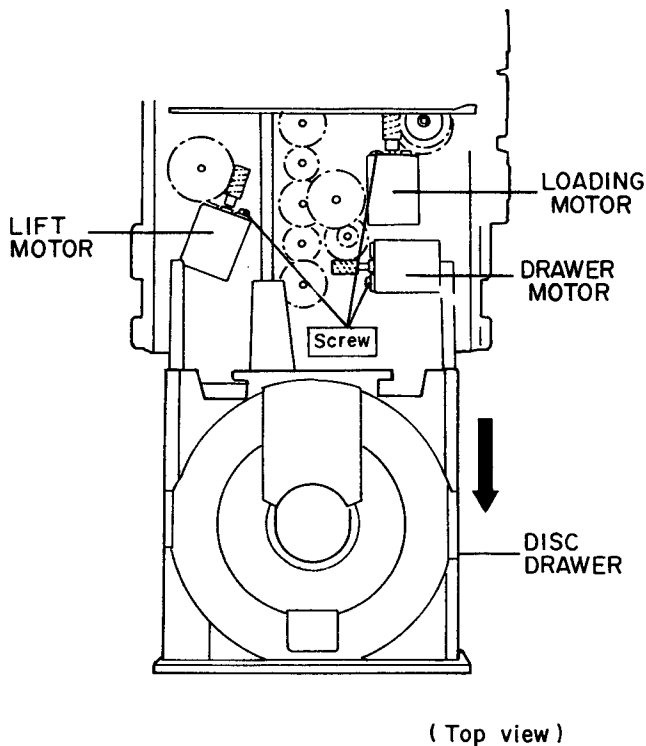

Fig.3-6

3-2-6. HOW TO REMOVE THE SLED MOTOR AND PICK-UP

A) SLED MOTOR

- 1) Remove the feed M belt.
- 2) Remove the SLED motor retaining screw ⑥.

B) PICK-UP

- 1) Remove the shaft base retaining screws ⑨.
- 2) Remove the P.U shaft and remove the pick-up.

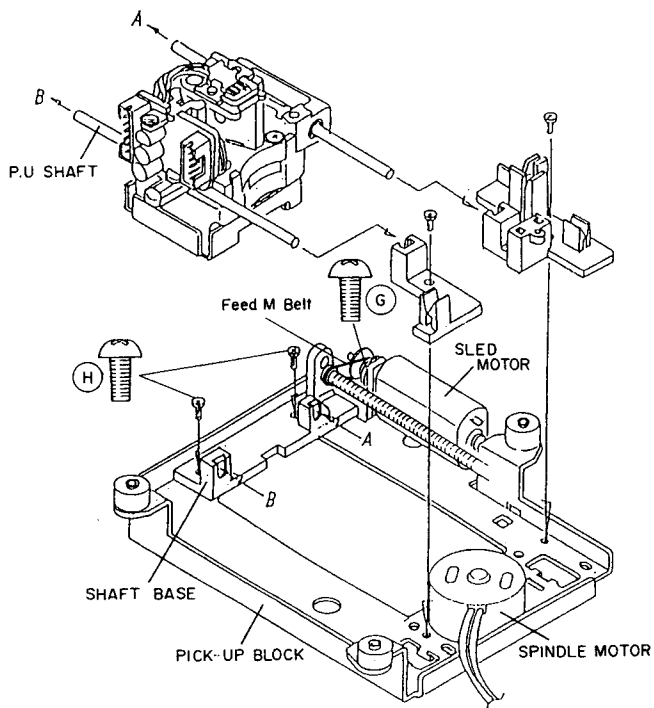

Fig. 3-7

3-2-7. HOW TO REMOVE THE SPINDLE MOTOR

- 1) Pull out the turntable from the spindle motor shaft.
- 2) Remove the SPINDLE motor retaining screws ①.
 - Put the turntable on to the spindle motor shaft and adjust the turntable so that the height of the turntable from the chassis is 0.5 to 1.0 mm as shown in Fig 3-8.
 - After adjustment, paint-lock the turntable to the spindle motor.

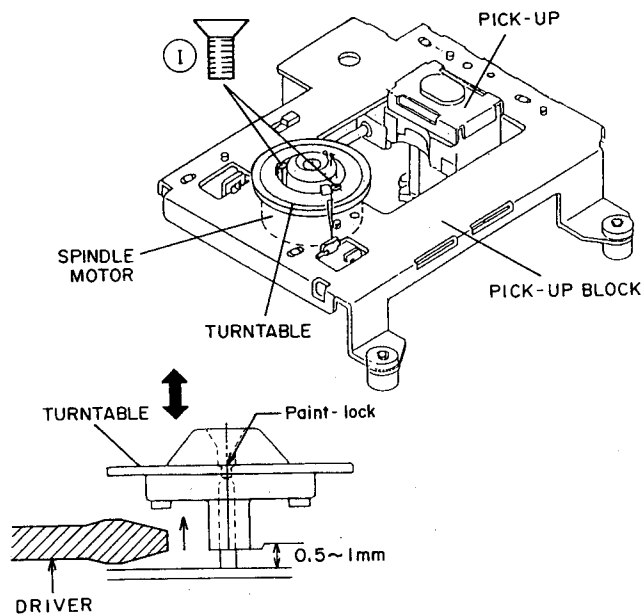

Fig.3-8

IV. ELECTRICAL ADJUSTMENT

[ABOUT THE TEST MODE]

- This TEST mode is used for adjustment or checking.
- How to set engage the TEST mode.

[When amplifier is AM-M830/AM-M630]

- 1) Set the TEST DISC to the No.1 MAGAZINE PACK
- 2) While pressing the $\triangleright/\text{STOP}$ and \square button of the CD-M830M, connect the AC power cord of the amplifier to the AC power outlet.
- 3) While pressing the G.E.REC button, press the POWER button of the amplifier to turn the power of the AM-M630/AM-M830 and CD-M830M on. FX TEST (initial TEST mode) will appear on the FLD of the CD-M830M.

[When amplifier is AX-M430]

- 1) Set the TEST DISC to the No.1 MAGAZINE PACK.
- 2) While pressing the $\triangleright/\text{STOP}$ and \square button of the CD-M830M, connect the AC power cord of the amplifier to the AC power outlet.
- 3) While pressing the PLAY (\triangleright) button, press the POWER button of the amplifier to turn the power of the AX-M430 and CD-M830M on.

- How to change the TEST mode number.

Press the DISC NUMBER button (1 to 6) on the FRONT PANEL. When to return to the initial TEST mode condition, press the \square button.

- To cancel the TEST mode.

[When amplifier is AM-M830/AM-M630]

- 1) Turn off the power of the amplifier and CD-M830M by disconnecting the AC power cord.
- 2) While pressing the $\triangleright/\text{STOP}$ and \square button of the CD-M830M, connect the AC power cord of the amplifier to the AC outlet.
- 3) While pressing the G.E.REC button, press the POWER button of the amplifier to turn the power of the AM-M630/AM-M830 and CD-M830M on.
- 4) The TEST mode is now cancelled.

[When amplifier is AX-M430]

- 1) Turn off the power of the amplifier and CD-M830M by disconnecting the AC power cord.
- 2) While pressing the $\triangleright/\text{STOP}$ and \square button of the CD-M830M, connect the AC power cord of the amplifier to the AC outlet.
- 3) While pressing the PLAY (\triangleright) button, press the POWER button of the amplifier to turn the power of the AM-M630/AM-M830 and CD-M830M on.
- 4) The TEST mode is now cancelled.

- When the tuner is connected, turning power on and off will cancel the TEST mode.

- TEST mode condition and DISPLAY

TEST MODE	DISPLAY	
Initial condition	FX TEST	• Indicates unit is set into the TEST mode.
1 or 2	0 000 ^{1 2}	• Indicates end of FOCUS SEARCH.
3	0 000 ³	• Set into the CLV-S mode.
4	0 000 ⁴	• Tracking servo is on.
5	21200 ⁵	• Set into the CLV-S mode, tracking servo is on. • After this, track NO. and total time become normal indication. (Playback Track NO.21)
6	21200 ⁶	• Same as normal playback mode.

5 FOCUS OFF-SET

1. Test disc 5A (AT-751330)
2. Test mode 2 and 1
3. JW43 (FE) / VR 5
- Connect a digital DC voltmeter to JW43 (FE) and check voltage A in the test mode 2, then press STOP button and adjust voltage B so that the reading on the digital DC voltmeter is same as voltage A.
*A=B

2 E-F BALANCE

1. Test disc 5A (AT-751330)
2. Test mode 3
3. JW44 (TE) / VR 2
- Connect an oscilloscope to JW44 (TE)
*A=B

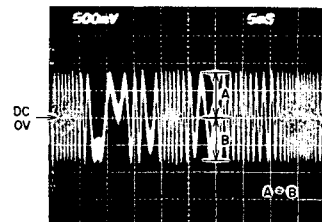

1 PLL

1. —
2. 10 seconds after power is on.
3. JW124(WFCK) / VR 1
- Connect a frequency counter to JW124 (WFCK).
• Connect JW41 (EFM) to JW42 (GND) by jumper wire.
*7,350 ± 50 Hz

STEP	ADJUSTMENT
1.	Test disc
2.	Mode or Test mode
3.	Test point / ADJ parts
4.	(*) Remark (*) Result

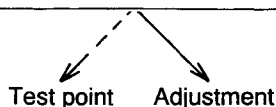

	<ul style="list-style-type: none"> Indicates unit is set into the TEST mode.
2	<ul style="list-style-type: none"> Indicates end of FOCUS SEARCH. Set into the CLV-S mode.
	<ul style="list-style-type: none"> Tracking servo is on.
	<ul style="list-style-type: none"> Set into the CLV-S mode, tracking servo is on. After this, track NO. and total time become normal indication. (Playback Track NO.21)
	<ul style="list-style-type: none"> Same as normal playback mode.

4 FOCUS SERVO GAIN

- Test disc 5A (AT-751330)
- Test mode 5
- Pin ② (FCS) of connector P2 / VR 3
- Connect an oscilloscope to pin ② (FCS) of connector P2.

*0.5 Vp-p

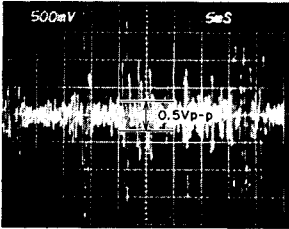

3 TRACKING SERVO GAIN

- Test disc 5A (AT-751330)
- Test mode 5
- Pin ④ (TRK) of connector P2 / VR 4
- Connect an oscilloscope to pin ④ (TRK) of connector P2.

*0.2 Vp-p.

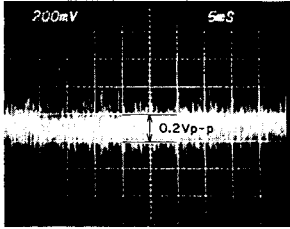

to JW43
test mode
and adjust
the digital
e A.

44 (TE)



(GND)

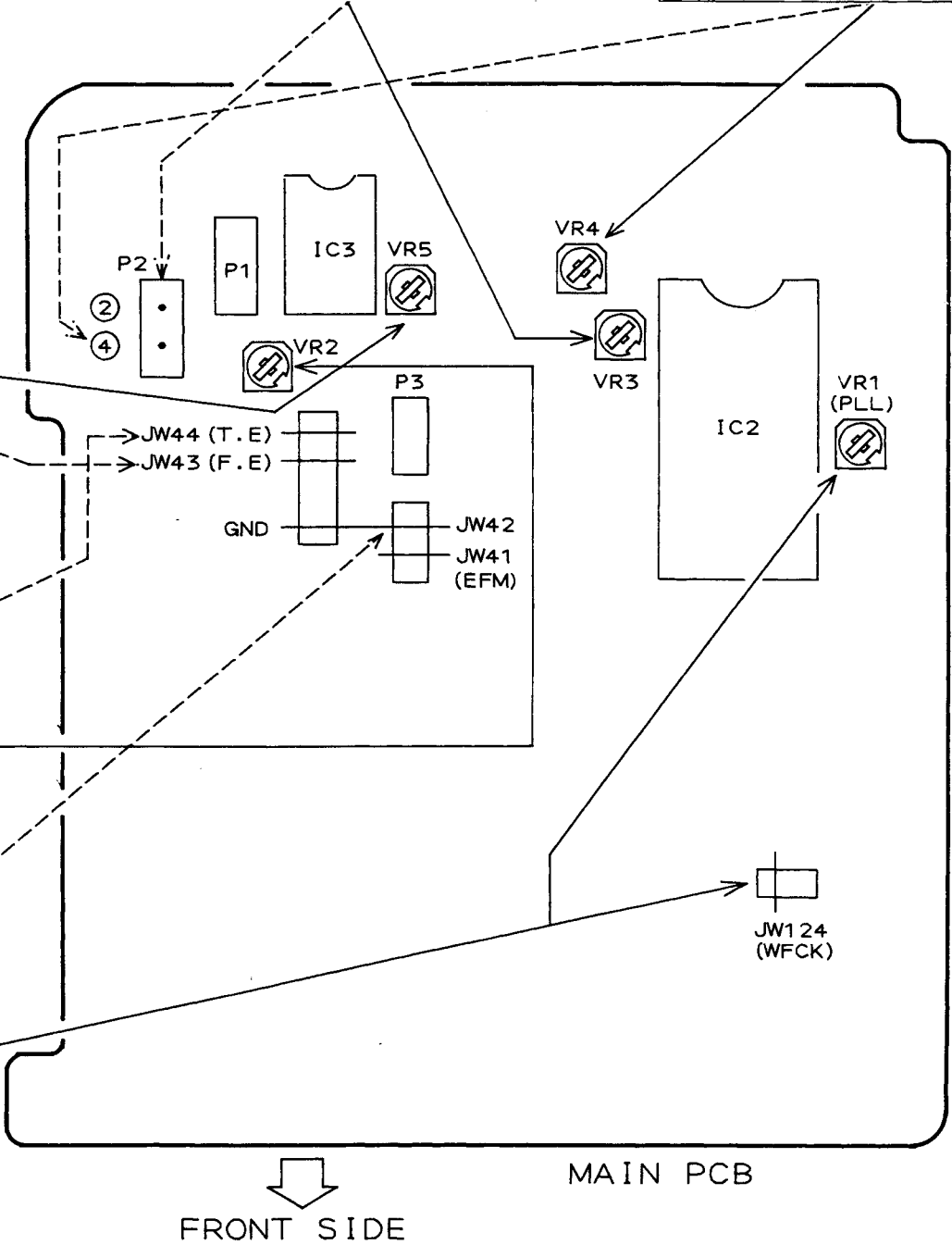

V. PARTS LIST

ATTENTION

1. When placing an order for parts, be sure to list Part No., Model No. and the description of each part. Otherwise, the non-delivery of the part or the delivery of a wrong part may result.
2. Please make sure that Part No. is correct when ordering. If not, a part different from the one you ordered may be delivered.
3. Since the parts shown in Parts List of Preliminary Service Manual may have been the subject of changes, please use this Parts List for all future reference.

HOW TO USE THIS PARTS LIST

1. This Parts List lists those parts which are considered necessary for repairs. Other common parts, such as resistors and capacitors, are listed in the "Common List for Service Parts" from which these parts should be selected and stocked.
2. The Recommended Spare Parts List shows those parts in the Parts List which are considered particularly important for service.
3. Parts not shown in the Parts List and "Common List for Service Parts" will not in principle be supplied.
4. How to read the Parts List.

a) Mechanism Block

2. HEAD BASE BLOCK

Ref. No.	Part No.	Description
1	BH-T2023A320A	HEAD BASE BLOCK
2	HP-H2206A010A	HEAD R/P PR4-8FU C
3	ZS-477876	PAN20×03STL CMT
4	ZS-536488	BID20×08STL CMT
5	ZG-402895	SP CS ANGLE ADJUST

↑
 ↑
 SP (Service Parts) Classification
 This number corresponds with the individual parts index number in that figure.

b) PC Board

6. MAIN PC BOARD

Ref. No.	Part No.	Description
IC1	EI-324536	IC HD14049BP
IC2	EI-336801	IC MB8841-564M
C1A	EC-338399	C MMY V 223M 250AC [U,E,B,S]
C1B	EC-350949	C MMY V 223M 250DC [J]
C1C	EC-338397	C MMY V 223M 125AC [C,A]
X1	EI-318384	OSC X'TAL NC-18C

↑
 ↑
 Symbols for primary destination
 [A] : AAL (U.S.A) [S] : SAA (Australia)
 [B] : BEAB (England) [U] : U/T (Universal Area)
 [C] : CSA (Canada)
 [E] : CEE (Europe) [V] : VDE (Germany)
 [J] : JPN (Japan) [Y] : Custom Version
 ↑
 SP (Service Parts) Classification
 These reference symbols correspond with component symbols in the Schematic Diagrams.

The available PC Board Blocks are listed separately.

5. When Part No. is known, Parts Index at end of Parts List can be used to locate where that part is shown in Parts List by its Reference No. listed at right of Part No.

WARNING

△ (*) INDICATES SAFETY CRITICAL COMPONENTS. FOR CONTINUED SAFETY, REPLACE SAFETY CRITICAL COMPONENTS ONLY WITH MANUFACTURE'S RECOMMENDED PARTS.

AVERTISSEMENT

△ (*) IL INDIQUE LES COMPOSANTS CRITIQUES DE SÉCURITÉ. POUR MAINTENIR LE DEGRÉ DE SÉCURITÉ DE L'APPAREIL, NE REMPLACER QUE DES PIÈCES RECOMMANDÉES PAR LE FABRICANT.

1. RECOMMENDED SPARE PARTS

We suggest you to stock the following Recommended Spare Part items listed below since they can cover most of the routine service.

Ref.No.	Part No.	Description
1	BB-405228J	MECHA CD CHANGEER P2065
2	BM-732748J	MOTOR FF-050SH
3	BM-732740J	MOTOR RF-300C-11440
4	BM-374198	MOTOR RF-370C15370
5	BO-732758J	PICK UP TAOHS-KP1
6	EC-391843J	C DOUBLE FYDOH 223Z 5.5DC
7	ED-394416J	D LED SLV-31VT3F RED
8	ED-307572	D SILICON H 1SS131
9	ED-511907	D SILICON 1N4002 100/1.0A
10	ED-393759J	D ZENER H HZS6B1L F05
11	ED-400171J	D ZENER H HZS6C2L F05
12	ED-396063J	D ZENER H HZS7B1
13	ED-387820J	D ZENER H HZS9A2L F05
14	ED-400175J	D ZENER H HZS9B1L F05
15	EH-405239J	COMP R RGLD14T 223J
16	EH-405240J	COMP R RGL11X 472J
17	EI-389264J	IC BA6209N
18	EI-390112J	IC CXA1081S
19	EI-390120J	IC CXA1082BS
20	EI-403497J	IC CXD1167Q
21	EI-405231J	IC LC3664ASLL-12
22	EI-400756J	IC NJM4558L-B
23	EI-405234J	IC S-8054ALR T05
24	EI-405232J	IC UPD75116CW FX2CDS-1-172
25	EI-405236J	IC UPD75268ACW FX2CD01-028
26	EI-390149J	OSC CE CST4.23MGW 4.230MHZ
27	EI-381139J	OSC X'TAL HC-49/U 16934.400KHZ
28	EJ-394490J	SOCKET OPTICAL GP1F32T
29	EM-401047J	IND FL FIP10EM7R CHARACTER
30	ES-732713J	FR DETECTION ASSY
31	ES-732728J	SW ASSY (03 301)
32	ES-732786J	SW LEAF MCV0024MPDO
33	ES-732729J	SW PUSH SPPB31
34	ES-732727J	SW SSCTL
35	ES-394427J	SW TACT SOR-133HS T05
36	ET-369248	TR DTA114YS
37	ET-371075	TR DTA124XS
38	ET-360399	TR DTC114TS
39	ET-354371	TR DTC124ES
40	ET-373392	TR DTC124XS
41	ET-353899	TR 2SA1317 S,T,U
42	ET-394555J	TR 2SA1515 Q,R
43	ET-389807J	TR 2SB1009 Q,R
44	ET-394919J	TR 2SB1329 Q,R T05
45	ET-400965J	TR 2SB1357 E,F T05
46	ET-389808J	TR 2SB1425 E,U
47	ET-400218J	TR 2SC1740S R,S
48	ET-396486J	TR 2SC4038 Q,R T05
49	ET-394917J	TR 2SD2005 Q,R T05
50	ET-394916J	TR 2SD2037 E,F T05
51	ET-396072J	TR 2SD2159 V,W
52	EW-394419J	WIRE ASSY P2059 12P
53	MB-732750J	BELT FEED M
54	ZG-732711J	SP SENSOR

2. CD MECHANISM

Ref.No.	Part No.	Description
2	MS-732707J	GUIDE BOSS
3	MS-732708J	TRAY SW GUIDE
4	MZ-732709J	TRAY SW BKT
5	ML-732710J	SENSOR LEVER
6	ZG-732711J	SP SENSOR
7	ES-732712J	SW ASSY (01 301)
9	ES-732713J	FR DETECTION ASSY
21	BM-374198	MOTOR RF-370C15370
22	MZ-732714J	E GEAR (A)
23	MZ-732715J	E GEAR (B)
24	MZ-732716J	E GEAR (C1)
25	MZ-732788J	E GEAR (C2)
36	ML-732720J	TRAY STOPPER

Ref.No.	Part No.	Description
37	ML-732721J	RELEASE LEVER (1)
38	ML-732722J	RELEASE LEVER (2)
39	ML-732723J	LOCK LEVER
40	ZG-732724J	SP RELEASE LEVER (04-31)
41	ZG-732725J	SP RELEASE LEVER (03-22)
44	ZG-732726J	SP SW HOLDER
45	ES-732727J	SW SSCTL
46	ES-732728J	SW ASSY (03 301)
50	ES-732729J	SW PUSH SPPB31
56	MZ-732730J	FE GEAR (A)
57	MZ-732731J	FE GEAR (B)
58	MZ-732732J	FE GEAR (D)
59	MZ-732734J	FE GEAR (E)
61	ML-732736J	HOOK SLIDE LEVER
62	MZ-732737J	RACK GEAR
63	ZG-732738J	SP RACK GEAR
64	ML-732739J	LOCK SP PLATE
66	BM-732740J	MOTOR RF-300C-11440
67	MZ-732741J	TURN TABLE
68	MD-732742J	TT PLATE
69	ZG-732743J	SP CONTROLER
70	MB-732744J	FLOATING RUBBER
71	ZG-732745J	SP FLOTING (B)
73	ZS-732746J	SCREW FLOATING
74	ZG-732747J	SP FLOTING
75	BM-732748J	MOTOR FF-050SH
76	MR-732749J	MOTOR PULLEY
77	MB-732750J	BELT FEED M
78	MZ-732751J	SHAFT HOLDER
79	MZ-732752J	SHAFT BASE (A)
80	MZ-732753J	FEED ASSY
82	MS-732754J	PU SHAFT
83	MZ-732755J	FEED NUT SUPPORT
84	ZG-732756J	SP FEED NUT
86	BO-732758J	PICK UP TAOHS-KP1
91	ML-732759J	RAIL (L)
92	ML-732760J	RAIL (R)
93	ML-732761J	HOOK LEVER
94	ZG-732762J	SP HOOK
95	ML-732763J	HOOK
96	ML-732765J	DETECT SW PLATE (C)
98	MZ-732766J	CLAMPER ASSY
107	MZ-732768J	SHAFT BASE (B)
109	MZ-732769J	P-BASE GUIDE ASSY
121	EP-732770J	COIL ASSY
122	MS-732771J	PLUNGER (A)
124	ML-732772J	SLIDE SW LEVER
125	ZG-732773J	SP SLIDE LEVER
127	ML-732774J	P RAIL (L)
128	ML-732775J	P RAIL (R)
129	MZ-732776J	P RAIL BASE
131	MZ-732777J	P GEAR (A)
132	MZ-732778J	P GEAR (B)
133	MZ-732779J	P GEAR (C)
134	MZ-732780J	P GEAR (D)
135	MZ-732781J	P GEAR (E)
138	ML-732782J	STOPPER
139	ZG-732783J	SP STOPPER
140	ML-732784J	P LOCK LEVER
141	MB-732785J	RUBBER
142	ES-732786J	SW LEAF MCV0024MPDO
143	MZ-732787J	P1 TRAY (B) E26609-002
196	ZS-283353	T2BID20X08STL CMT
197	ZS-377928	PT BID20X08STL CMT
200	ZS-390436J	PAN17X025STL BZN PS3
203	ZS-726033J	T2BID20X06
208	ZS-417216	PAN30X04STL CMT
209	ZS-477876	PAN20X03STL CMT
210	ZS-608095	PAN20X05STL CMT
211	ZS-460440	PAN20X04STL CMT
212	ZW-712292	PW21X050X040 PLS
213	ZW-324417	PW31X060X050PSL
214	ZW-344643	PW26X070X025PSL
215	ZW-270101	RING E 300SUP CMT

NOTE:

Parts will not be supplied if they are not listed in the parts list, even if they appear on the assembling illustrations with reference No.

CD MECHANISM

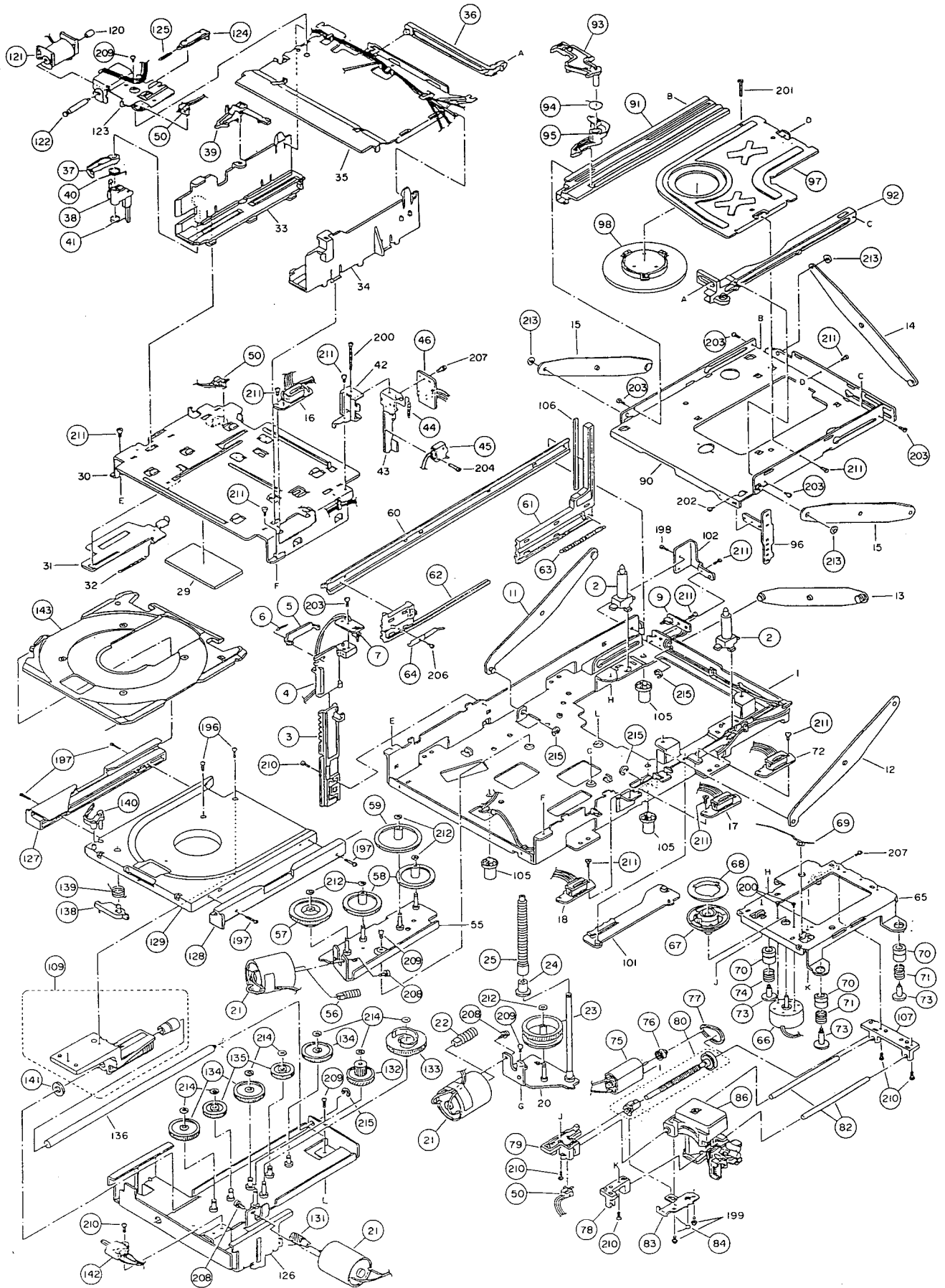

PARTS LIST

3. P.C BOARD BLOCK

Ref.No.	Part No.	Description
1	BA-P2065T020A	ML PC (#) MAIN BLK CD-M830M/ML

ML PC (#) MAIN BLK CONSISTS OF FOLLOWING P.C BOARD.

- MAIN P.C BOARD
- OPERATION P.C BOARD

4. MAIN P.C BOARD

Ref.No.	Part No.	Description
C66	EC-391843J	C DOUBLE FYDOH 223Z 5.5DC
D1	ED-511907	D SILICON 1N4002 100/1.0A
D2	ED-511907	D SILICON 1N4002 100/1.0A
D3	ED-511907	D SILICON 1N4002 100/1.0A
D4	ED-511907	D SILICON 1N4002 100/1.0A
D5	ED-511907	D SILICON 1N4002 100/1.0A
D6	ED-511907	D SILICON 1N4002 100/1.0A
D7	ED-387820J	D ZENER H HZS9A2L F05
D8	ED-393759J	D ZENER H HZS6B1L F05
D9	ED-400171J	D ZENER H HZS6C2L F05
D10	ED-400171J	D ZENER H HZS6C2L F05
D11	ED-307572	D SILICON H 1SS131
D13	ED-396063J	D ZENER H HZS7B1
D14	ED-511907	D SILICON 1N4002 100/1.0A
D15	ED-307572	D SILICON H 1SS131
D16	ED-307572	D SILICON H 1SS131
D17	ED-307572	D SILICON H 1SS131
D18	ED-511907	D SILICON 1N4002 100/1.0A
D19	ED-307572	D SILICON H 1SS131
IB1	EH-405239J	COMP R RGLD14T 223J
IB2	EH-405240J	COMP R RGLE11X 472J
IC1	EI-405232J	IC UPD75116CW FX2CDS-1-172
IC2	EI-390120J	IC CXA1082BS
IC3	EI-390112J	IC CXA1081S
IC4	EI-403497J	IC CXD1167Q
IC5	EI-405231J	IC LC3664ASLL-12
IC6	EI-389264J	IC BA6209N
IC8	EI-400756J	IC NJM4558L-B
IC9	EI-405234J	IC S-8054ALR T05
IC10	EI-400756J	IC NJM4558L-B
IC11	EI-400756J	IC NJM4558L-B
J4	EJ-394490J	SOCKET OPTICAL GP1F32T
TR1	ET-389807J	TR 2SB1009 Q,R
TR2	ET-400218J	TR 2SC1740S R,S
TR3	ET-400965J	TR 2SB1357 E,F T05
TR4	ET-400218J	TR 2SC1740S R,S
TR5	ET-369248	TR DTA114YS
TR6	ET-373392	TR DTC124XS
TR7	ET-394555J	TR 2SA1515 Q,R
TR8	ET-353899	TR 2SA1317 S,T,U
TR9	ET-360399	TR DTC114TS
TR10	ET-400218J	TR 2SC1740S R,S
TR11	ET-354371	TR DTC124ES
TR12	ET-394917J	TR 2SD2005 Q,R T05
TR13	ET-394919J	TR 2SB1329 Q,R T05
TR14	ET-394919J	TR 2SB1329 Q,R T05
TR15	ET-394916J	TR 2SD2037 E,F T05
TR16	ET-396072J	TR 2SD2159 V,W
TR17	ET-389808J	TR 2SB1425 E,U
TR18	ET-389808J	TR 2SB1425 E,U
TR19	ET-396072J	TR 2SD2159 V,W
TR20	ET-389808J	TR 2SB1425 E,U
TR22	ET-389808J	TR 2SB1425 E,U
TR23	ET-400218J	TR 2SC1740S R,S
TR24	ET-360399	TR DTC114TS
TR25	ET-360399	TR DTC114TS
TR26	ET-360399	TR DTC114TS
TR27	ET-360399	TR DTC114TS
TR28	ET-371075	TR DTA124XS
TR29	ET-371075	TR DTA124XS
TR30	ET-371075	TR DTA124XS
TR31	ET-354371	TR DTC124ES
TR32	ET-396072J	TR 2SD2159 V,W
TR33	ET-389808J	TR 2SB1425 E,U
TR34	ET-389808J	TR 2SB1425 E,U
TR35	ET-396072J	TR 2SD2159 V,W
TR36	ET-396072J	TR 2SD2159 V,W

Ref.No.	Part No.	Description
TR37	ET-389808J	TR 2SB1425 E,U
TR38	ET-389808J	TR 2SB1425 E,U
TR39	ET-400218J	TR 2SC1740S R,S
VR1	EV-405242J	R S-FIX H T05 EVMF6S 0.30W 102
VR2	EV-390872J1	R S-FIX H T05 RH0638C 0.1W 223
VR3	EV-390872J1	R S-FIX H T05 RH0638C 0.1W 223
VR4	EV-390872J1	R S-FIX H T05 RH0638C 0.1W 223
VR5	EV-390873J1	R S-FIX H T05 RH0638C 0.1W 472
X1	EI-381139J	OSC XTAL HC-49/U 16934.400KHZ
X2	EI-390149J	OSC CE CST4.23MGW 4.230MHZ

5. OPERATION P.C BOARD

Ref.No.	Part No.	Description
D101	ED-307572	D SILICON H 1SS131
D102	ED-307572	D SILICON H 1SS131
D103	ED-400175J	D ZENER H HZS9B1L F05
D104	ED-307572	D SILICON H 1SS131
D105	ED-307572	D SILICON H 1SS131
D106	ED-307572	D SILICON H 1SS131
D107	ED-307572	D SILICON H 1SS131
D108	ED-307572	D SILICON H 1SS131
D111	ED-394416J	D LED SLV-31VT3F RED
D112	ED-394416J	D LED SLV-31VT3F RED
D113	ED-394416J	D LED SLV-31VT3F RED
D114	ED-394416J	D LED SLV-31VT3F RED
IC101	EI-405236J	IC UPD75268ACW FX2CD01-028
IN101	EM-401047J	IND FL FIP10EM7R CHARACTER
SW101	ES-394427J	SW TACT SOR-133HS T05
SW102	ES-394427J	SW TACT SOR-133HS T05
SW103	ES-394427J	SW TACT SOR-133HS T05
SW104	ES-394427J	SW TACT SOR-133HS T05
SW105	ES-394427J	SW TACT SOR-133HS T05
SW106	ES-394427J	SW TACT SOR-133HS T05
SW107	ES-394427J	SW TACT SOR-133HS T05
SW108	ES-394427J	SW TACT SOR-133HS T05
SW109	ES-394427J	SW TACT SOR-133HS T05
SW110	ES-394427J	SW TACT SOR-133HS T05
SW111	ES-394427J	SW TACT SOR-133HS T05
SW112	ES-394427J	SW TACT SOR-133HS T05
SW113	ES-394427J	SW TACT SOR-133HS T05
SW114	ES-394427J	SW TACT SOR-133HS T05
SW115	ES-394427J	SW TACT SOR-133HS T05
SW116	ES-394427J	SW TACT SOR-133HS T05
TR101	ET-373392	TR DTC124XS
TR102	ET-373392	TR DTC124XS
TR103	ET-400218J	TR 2SC1740S R,S
TR104	ET-400218J	TR 2SC1740S R,S
TR105	ET-400218J	TR 2SC1740S R,S
TR106	ET-400218J	TR 2SC1740S R,S
TR107	ET-396486J	TR 2SC4038 Q,R T05

AKAI

MODEL **CD-M830M**

SCHEMATIC DIAGRAMS AND PC BOARDS

RTV servis Horvat

Kešinci, 31402 Semeljci

031-856-139

031-856-637

098-788-319

rtv-servis-horvat@os.tel.hr

Croatia

TABLE OF CONTENTS

1. BLOCK DIAGRAM	3
2. SCHEMATIC DIAGRAM	4
3. MAIN PC BOARD	5
4. FRONT PC BOARD	6
5. INFORMATION OF ICs	7

Use the following schematic diagrams and PC boards together with the provided service manual.

PRINCIPAL PARTS LOCATION

- ICs**
- IC1 E2,3
 - IC2 B,C3
 - IC3 B4
 - IC4 D1
 - IC5 F2,3
 - IC6 D3
 - IC8 B,C3
 - IC9 E3
 - IC10 D4
 - IC11 D4

- CONNECTORS**
- P1 B4
 - P2 B4
 - J3 A3
 - J4 A1
 - W1 F1,2
 - W2 C,D4
 - W3 D4
 - W4 E4
 - W5 F4

- TRANSISTORS**
- TR1 A1,2
 - TR2 A1,2
 - TR3 A2
 - TR4 A2
 - TR5 A2
 - TR6 B2
 - TR7 B3
 - TR8 B3
 - TR9 C1
 - TR10 C1
 - TR11 D1
 - TR12 D2
 - TR13 D3
 - TR14 D3
 - TR15 D3
 - TR16 C3
 - TR17 C3
 - TR18 C3
 - TR19 C3
 - TR20 C3
 - TR22 E3
 - TR23 E3
 - TR24 E3
 - TR25 D3
 - TR26 D2
 - TR27 E1
 - TR28 F3
 - TR29 F3
 - TR30 F3
 - TR31 F4
 - TR32 D3
 - TR33 D3
 - TR34 D3
 - TR35 D3
 - TR36 E3
 - TR37 E3
 - TR38 A2
 - TR39 A2

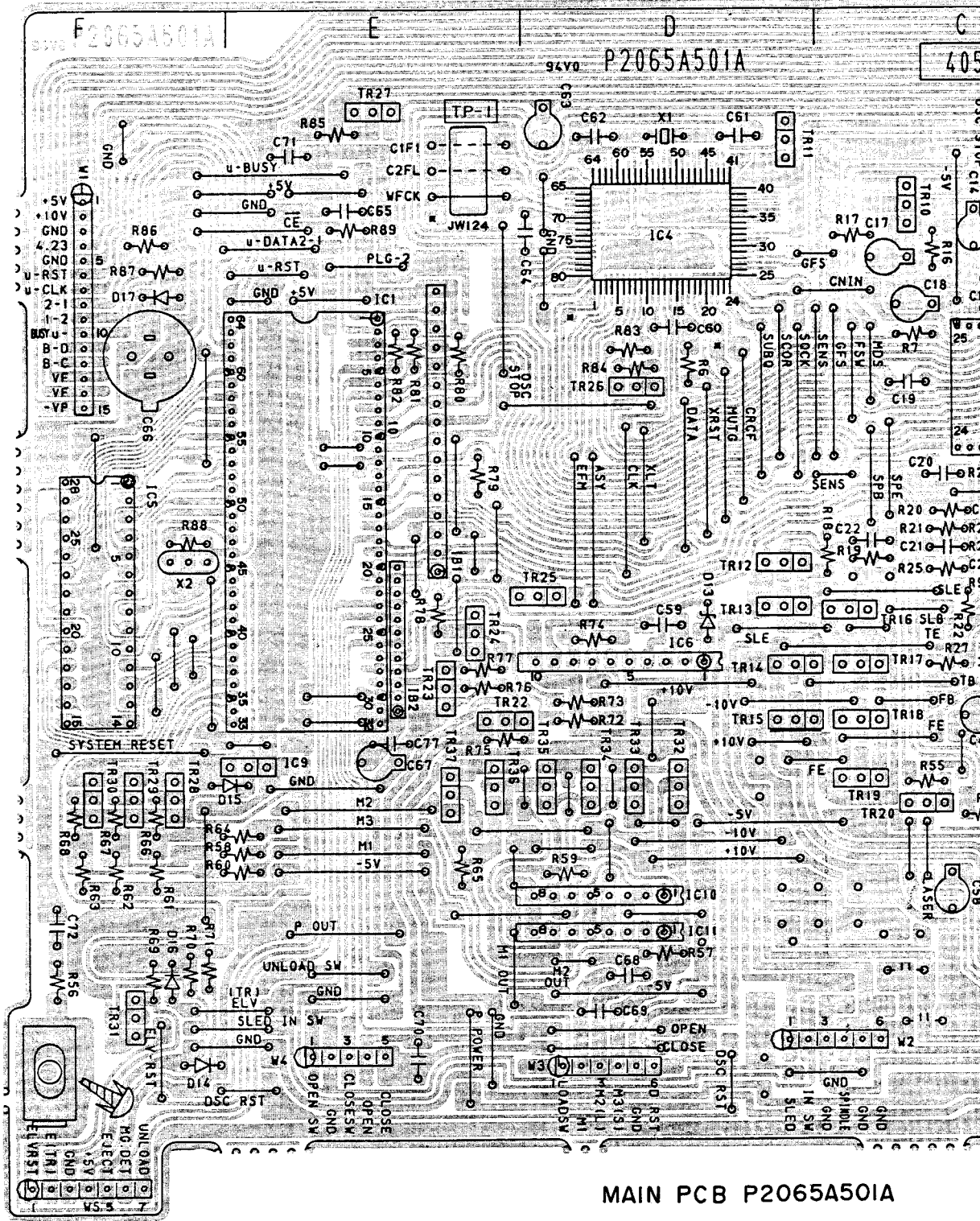

MAIN PCB P2065A501A

2065A501A

405820J

DIGITAL OUT
(OPTICAL)

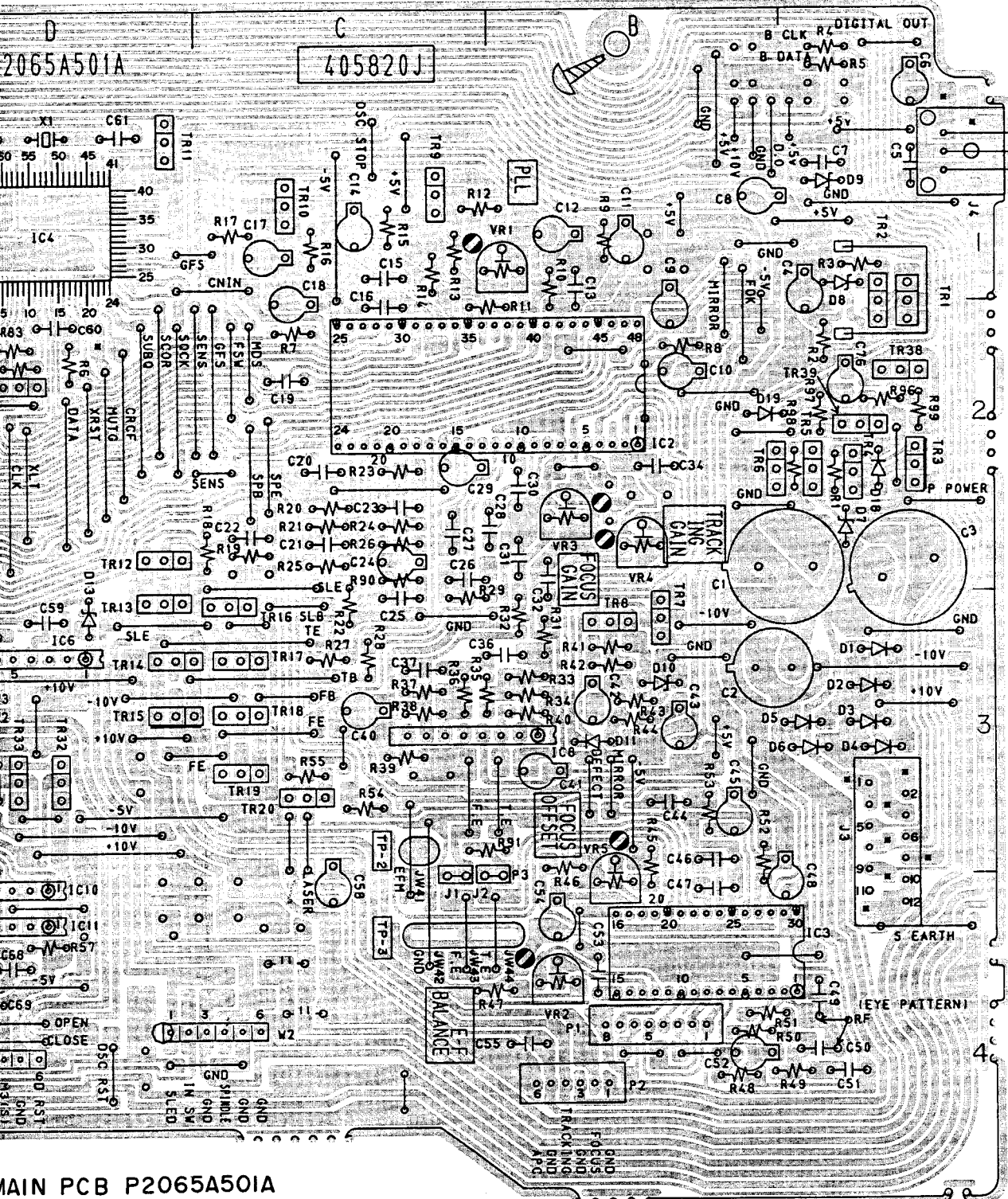

MAIN PCB P2065A501A

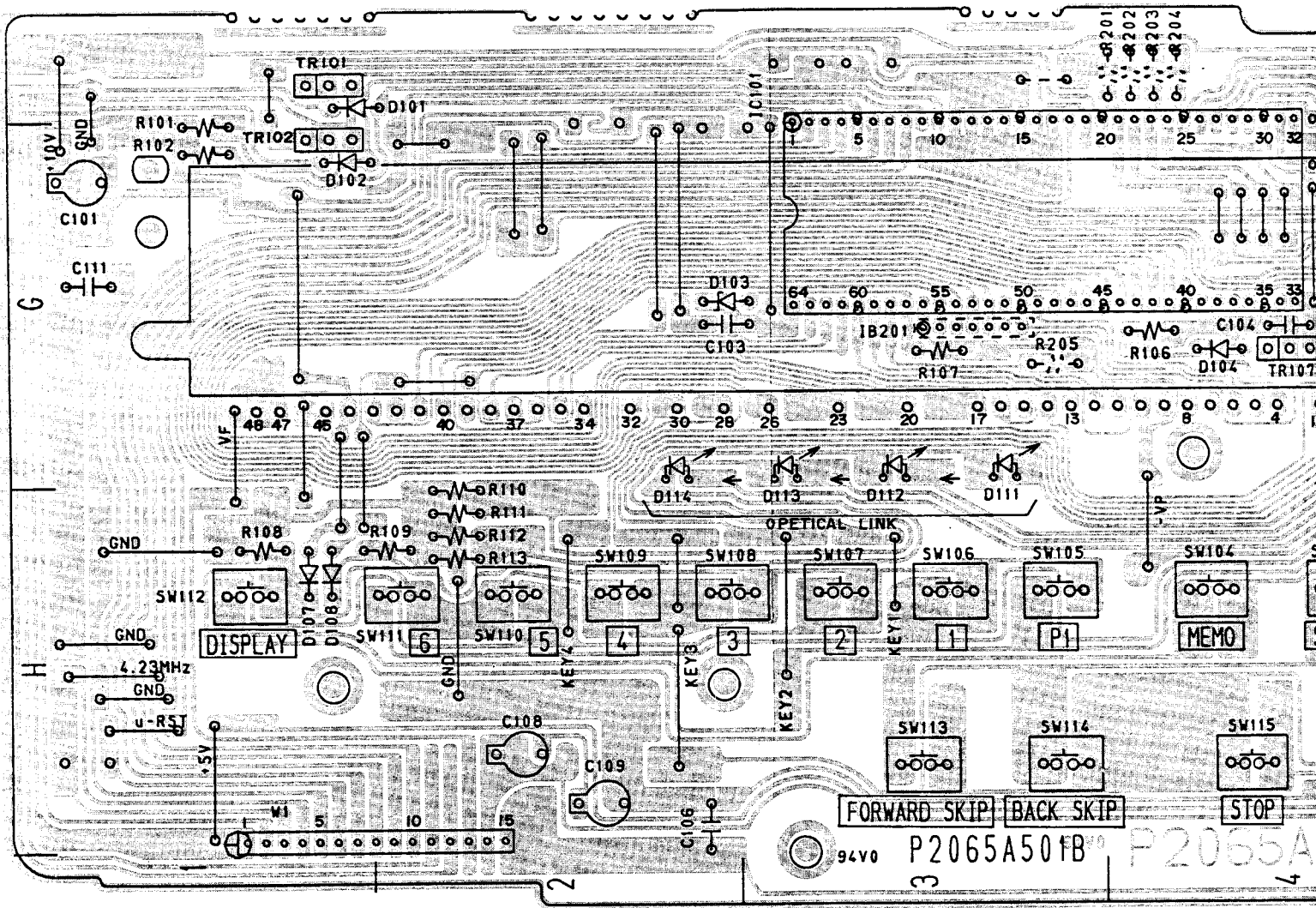

FRONT PCB P2065A50IB

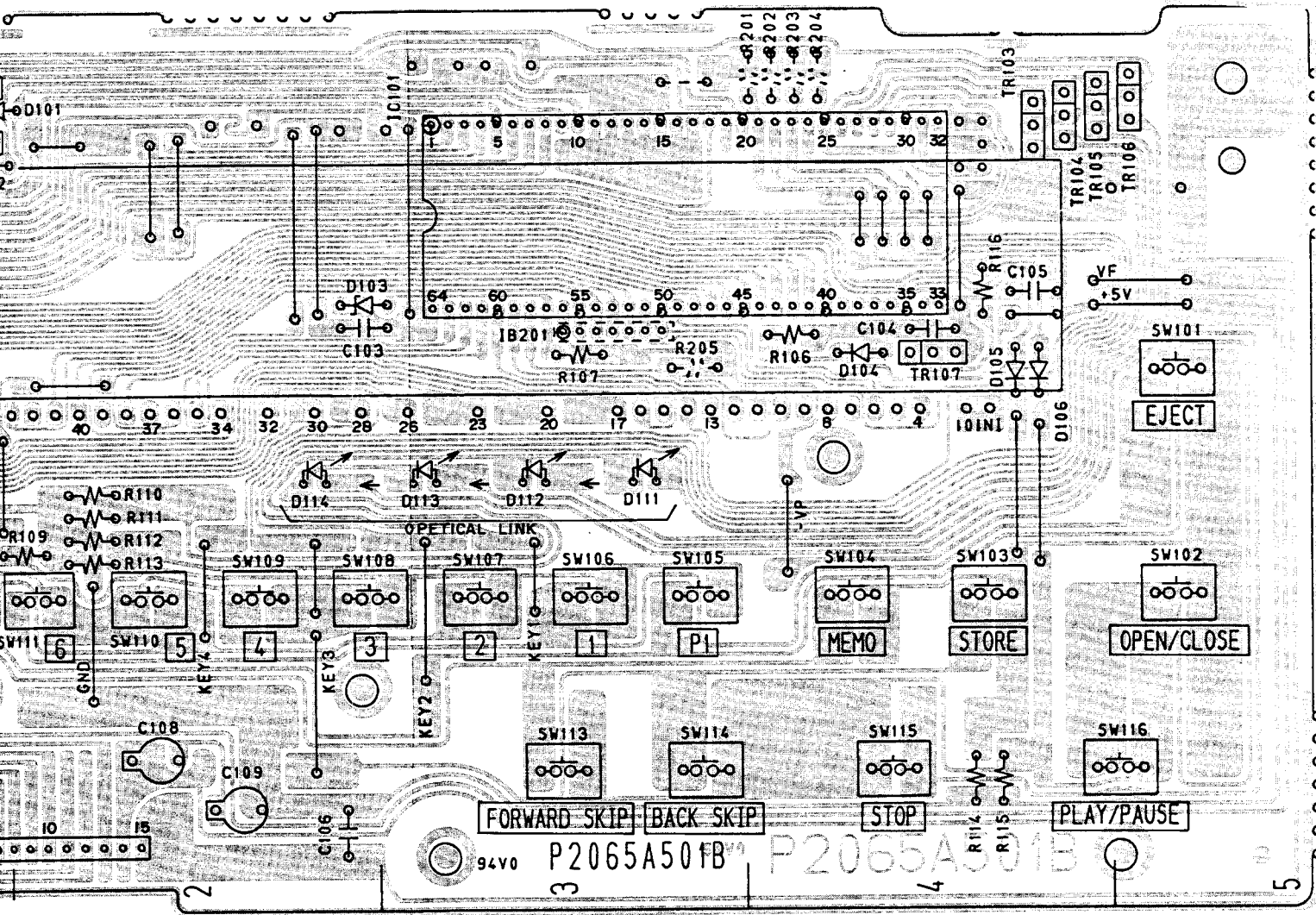

FRONT PCB P2065A50IB

CXD1167Q (DIGITAL SIGNAL PROCESOR)

Pin No.	Symbol	I/O	Description
1	FSW	O	Spindle motor filter switching control
2	MON	O	Spindle motor ON /OFF control
3	MPD	O	Spindle motor speed and phase control
4	MDS	O	Spindle motor speed control
5	EFM	I	EFM signal input
6	ASY	O	EFM signal slice level control
7	LOCK	O	Slide motor over reach guard signal output
8	VCOO	O	VCO output (f = 8.6436 MHz)
9	VCOI	I	VCO input
10	TEST	I	0 V (GND)
11	PDO	O	Phase comp.output
12	VSS	—	GND (0 V)
13	CLK	I	Clock signal input from CPU
14	XLT	I	Lutch signal input from CPU
15	DATA	I	Serial data input from CPU
16	XRST	I	System reset input L: RESET
17	CNIN	I	Tracking pulse input
18	SENS	O	Output of CPU interface
19	MUTG	I	Mute control signal input
20	CRCF	O	CRC check data output of the subcode Q
21	EXCK	I	Not use (GND)
22	SBSO	O	Not use
23	SUBQ	O	Subcode Q output
24	SCOR	O	Subcode sync detection output
25	SQCK	I/O	Clock signal for subcode Q
26	SQEX	I	Select input of SQCK (+ 5V)
27	DOTX	O	Digital output
28	GFS	O	H: Frame sync lock L: Frame sync unlock
29	TEST	I	0 V (GND)
32	TEST	I	0 V (GND)
33	Vdd	—	+ 5 V (Power supply)
34	TEST	I	0 V (GND)
50	TEST	I	0 V (GND)
51	C4M	O	Not use
52	Vss	—	GND
53	XTAI	I	X'tal OSC input (f = 16.9344 MHz)
54	XTAO	O	X'tal OSC output (f = 16.9344 MHz)
55	MD1	I	Not use
56	MD2	I	Mode select input 2 0 V (GND)
57	MD3	I	Mode select input 3 + 5 V
58	SLOB	I	Code select input for audio data 0 V (GND)
59	PSSL	I	Mode select input for audio data 0 V (GND)
60	APTR	O	Not use
61	APTL	O	Not use
62	C1F1	O	TP-1 C1F1
63	C1F2	O	Not use
64	C2F1	O	Not use
65	C2F2	O	TP-1 C2FL
66	C2FL	O	TP-1 WFCK
67	C2PO	O	Not use
68	RFCK	O	Not use
69	WFCK	O	Not use
70	PLCK	O	Not use
71	UGFS	O	Not use
72	GTOP	O	Not use
73	Vdd	—	+ 5 V (Power supply)
74	RAOV	O	Not use
75	C4LR	O	Not use
76	BCLK	O	Bit clock for input data
77	BCLK	O	Not use
78	DATA	O	Serial data output
79	WDCK	O	Word clock output
80	LRCK	O	L/R clock output

Pin No.	Symbol	I/O	Description																													
1	μ-BSY	I	Busy signal input for indicator																													
2	μ-IDT	I	Serial data input for indicator																													
3	SCOR	I	Subcode sync input																													
4	SUBQ	I	Subcode serial data input																													
5	DSCRST	I	Disc reset position detect input																													
6	ELERST	I	Elevator reset position detect input																													
7	MGDET	I	Magazine insertion detect input																													
8	FOK	I	Focus lock detection input																													
9	SENS	I	Auto sequency and detection input																													
10	CRCF	I	Result input of CRC(Error) check																													
11	μ-RST	O	Reset control output for indicator																													
12	CE	O	Chip enable output (L : active)																													
13	XLT	O	Latch signal output																													
14	XRST	O	Reset signal output																													
15	GFS	I	PLL (Frame sync) condition detect signal input																													
16	DATA	O	Command data output (Serial data)																													
17	CLK	O	Clock signal output																													
18	ELV	I	Elevator pulse input																													
19	MUTG	O	Muting control output																													
20	SQLK	O	Reading clock output of subcode Q data																													
21	LDON	O	Laser diode ON/OFF control output																													
22	OSCSTP	O	Oscilator control output for DSP and Servo																													
23	OPEN	I	Tray open position detect input																													
24	CLOSE	I	Tray close position detect input																													
25	LOAD	I	Disc load position detect input																													
26	UNLOAD	I	Disc unload position detect input																													
27	M.OPEN	O	Tray open control output for drawer motor																													
28	M.CLOSE	O	Tray close control output for drawer motor																													
29	PLG-1	O	Eject control output for Magazine																													
30	PLG-2	O	Eject control output for Magazine																													
31	—	—	Not used																													
32	Vdd	—	+ 5 V (Power supply)																													
33	M3	O	Motor logic control output for LIFT motor and LOADING motor																													
34	M2	O																														
35	M1	O																														
				<table border="1"> <thead> <tr> <th rowspan="2"></th> <th colspan="2">Loading.M</th> <th colspan="3">Lift.M</th> </tr> <tr> <th>load</th> <th>unload</th> <th>up</th> <th>down</th> <th>stop</th> </tr> </thead> <tbody> <tr><td>M1</td><td>L</td><td>H</td><td>L</td><td>H</td><td>L</td></tr> <tr><td>M2</td><td>H</td><td>L</td><td>L</td><td>H</td><td>L</td></tr> <tr><td>M3</td><td>L</td><td>H</td><td>H</td><td>L</td><td>L</td></tr> </tbody> </table>		Loading.M		Lift.M			load	unload	up	down	stop	M1	L	H	L	H	L	M2	H	L	L	H	L	M3	L	H	H	L
	Loading.M		Lift.M																													
	load	unload	up	down	stop																											
M1	L	H	L	H	L																											
M2	H	L	L	H	L																											
M3	L	H	H	L	L																											
36	SLED IN	I	RAM data																													
37	D3	I/O																														
38	D2	I/O																														
39	D1	I/O																														
40	D0	I/O																														
41	D7	I/O																														
42	D6	I/O																														
43	D5	I/O																														
44	D4	I/O																														
45	RESET	I	Reset input																													
46	X2	O	X'tal connection terminal																													
47	X1	I	X'tal connection terminal																													
48	A3	O	Address control output																													
49	A2	O																														
50	A1	O																														
51	A0	O																														
52	A7	O																														
53	A6	O																														
54	A5	O																														
55	A4	O																														
56	A11	O																														
57	A10	O																														
58	A9	O																														
59	A8	O																														
60	WE	O	Write enable control output																													
61	A12	O	Address control output																													
62	μ-ODT	O	Serial data output for indicator																													
63	μ-CLK	O	Clock signal output																													
64	Vss	—	0 V (GND)																													

RTV servis Horvat

Kešinci, 31402 Semeljci

031-856-139

031-856-637

098-788-319

rtv-servis-horvat@os.tel.hr

Croatia

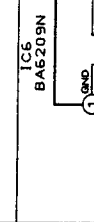
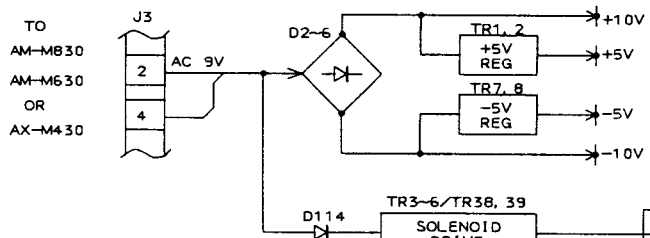
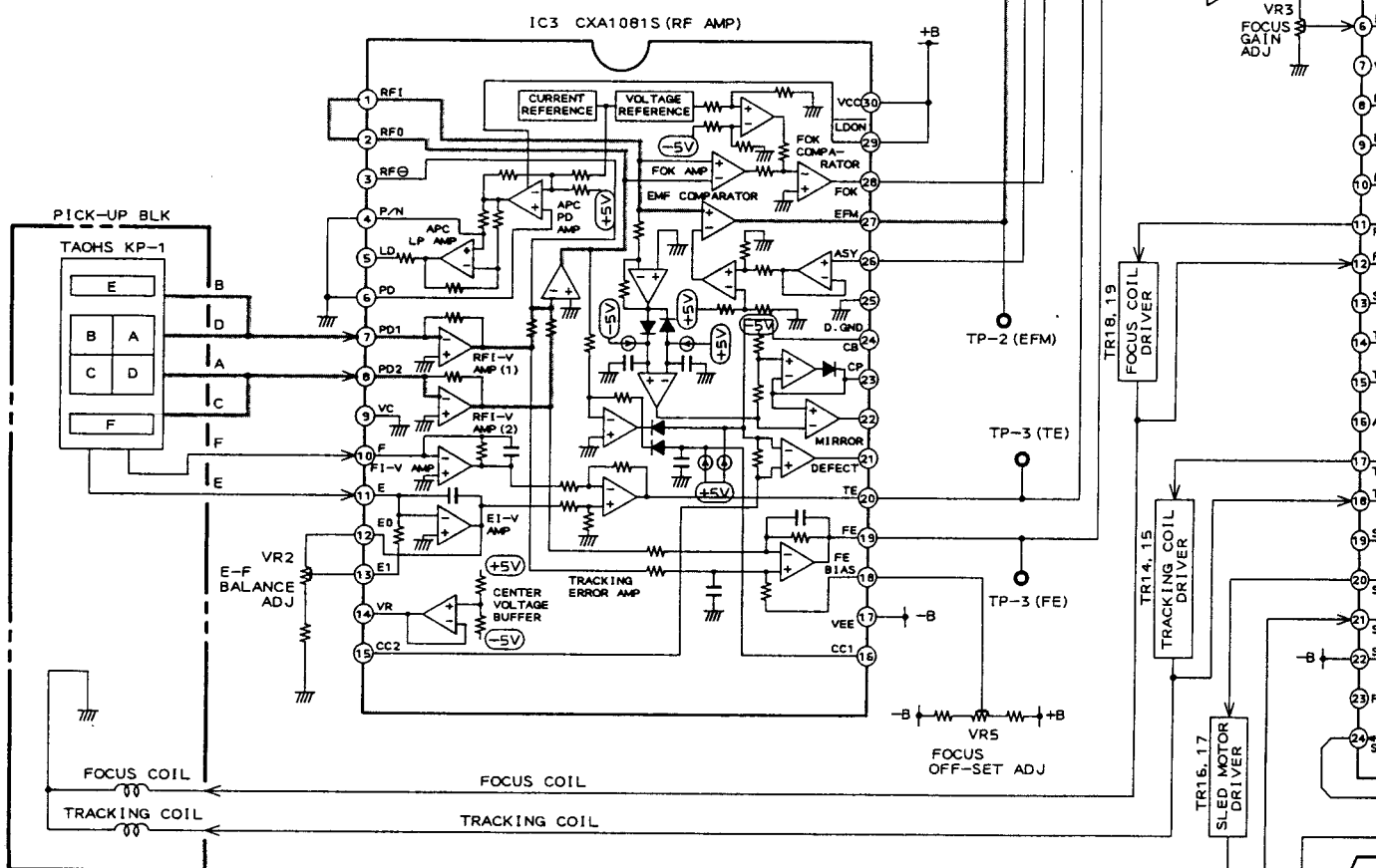
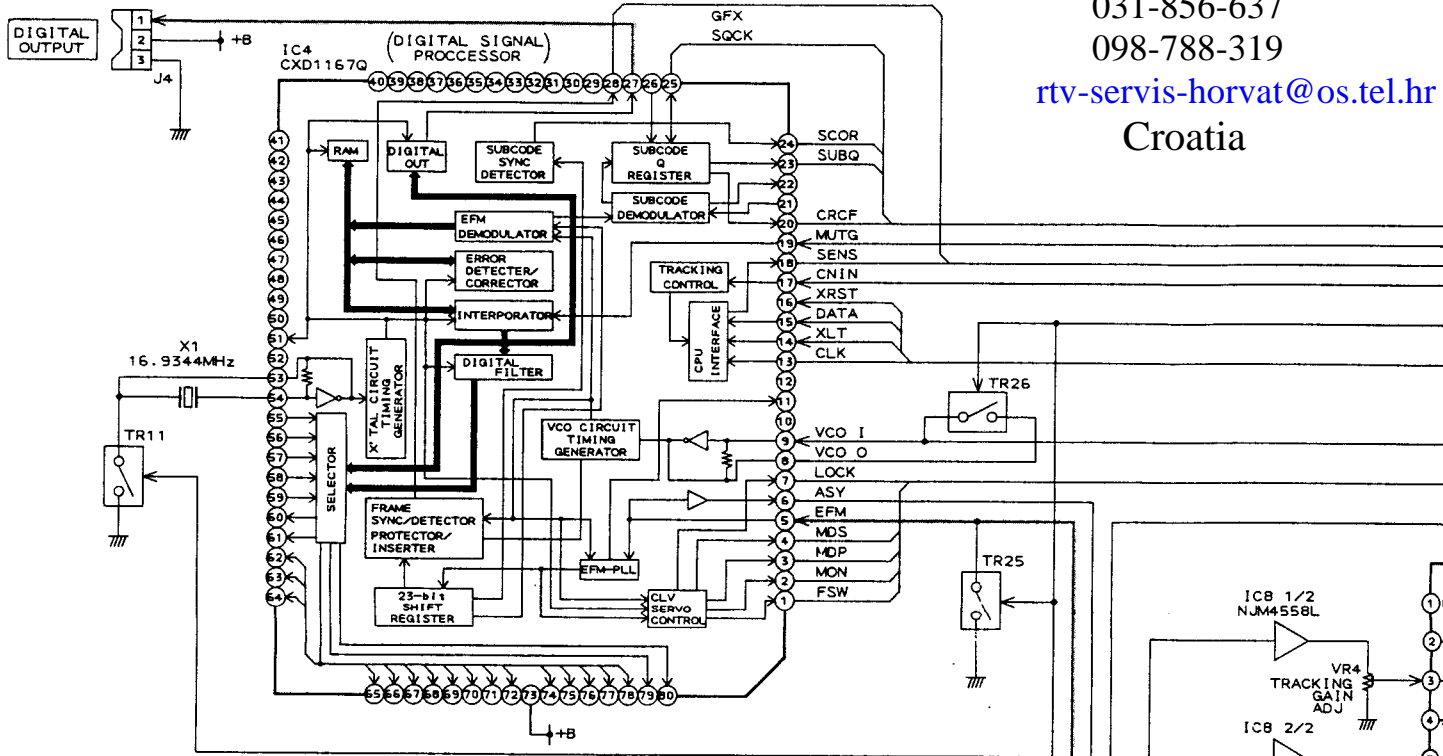

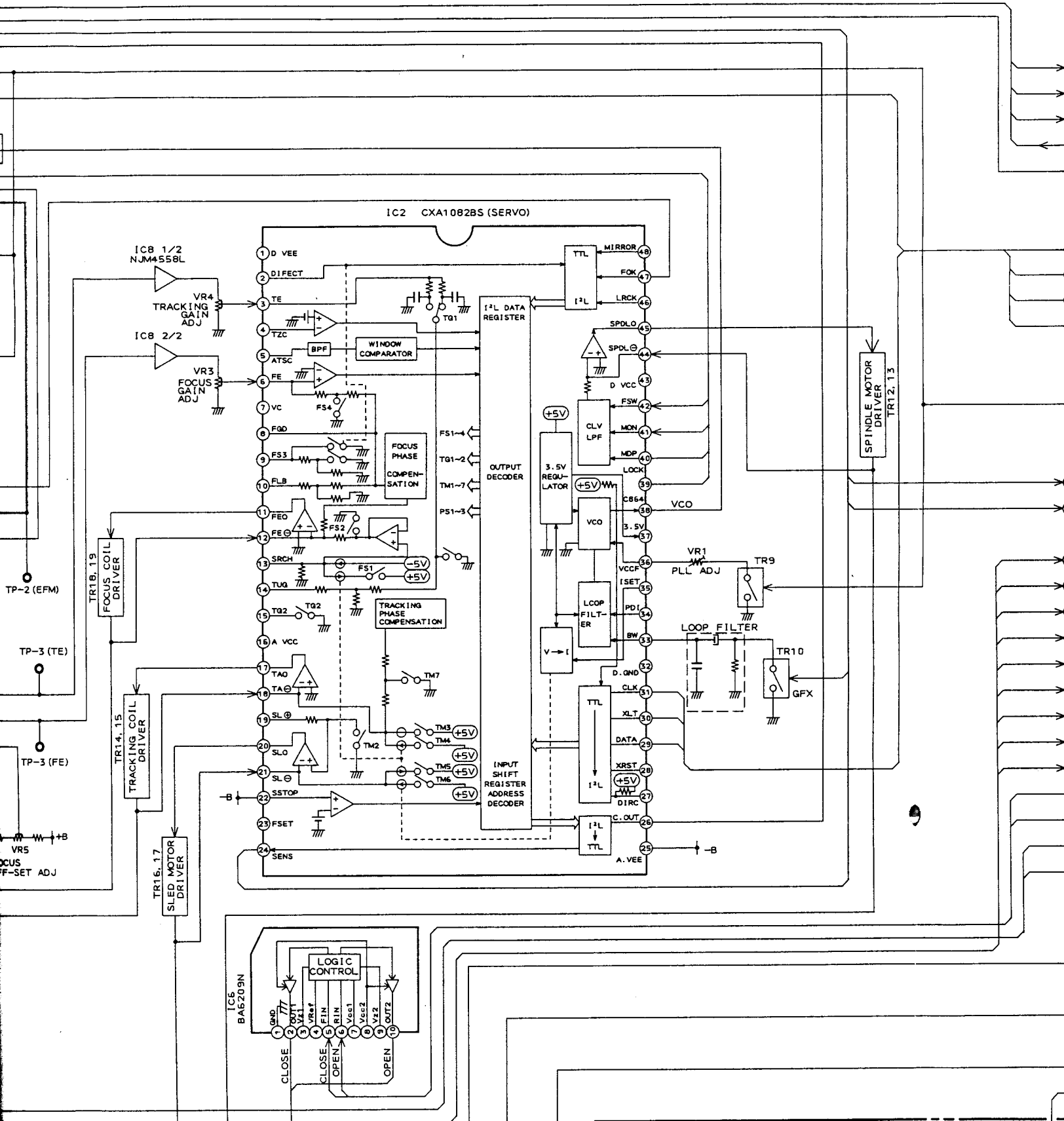

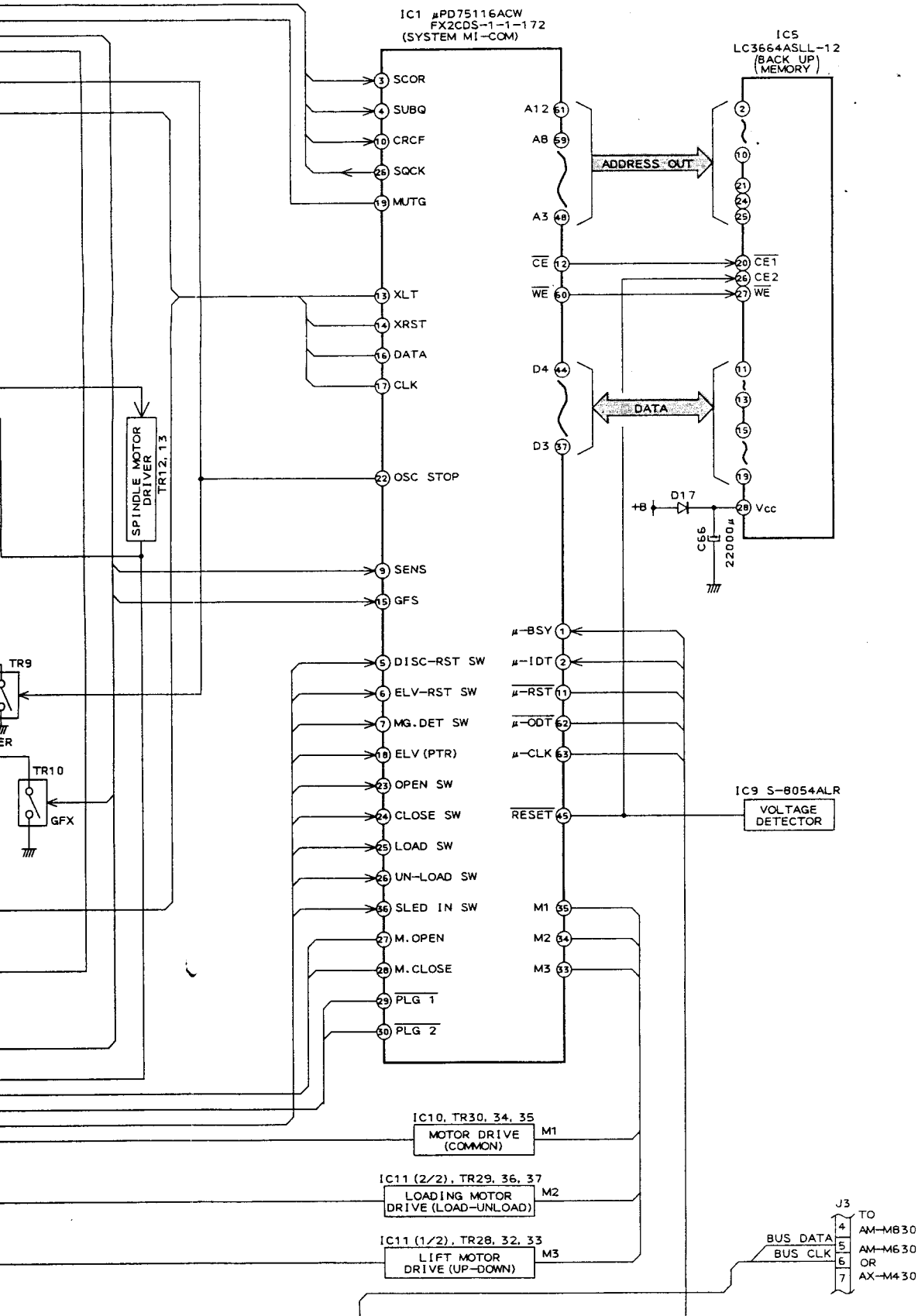

3
4
5
6
7
8

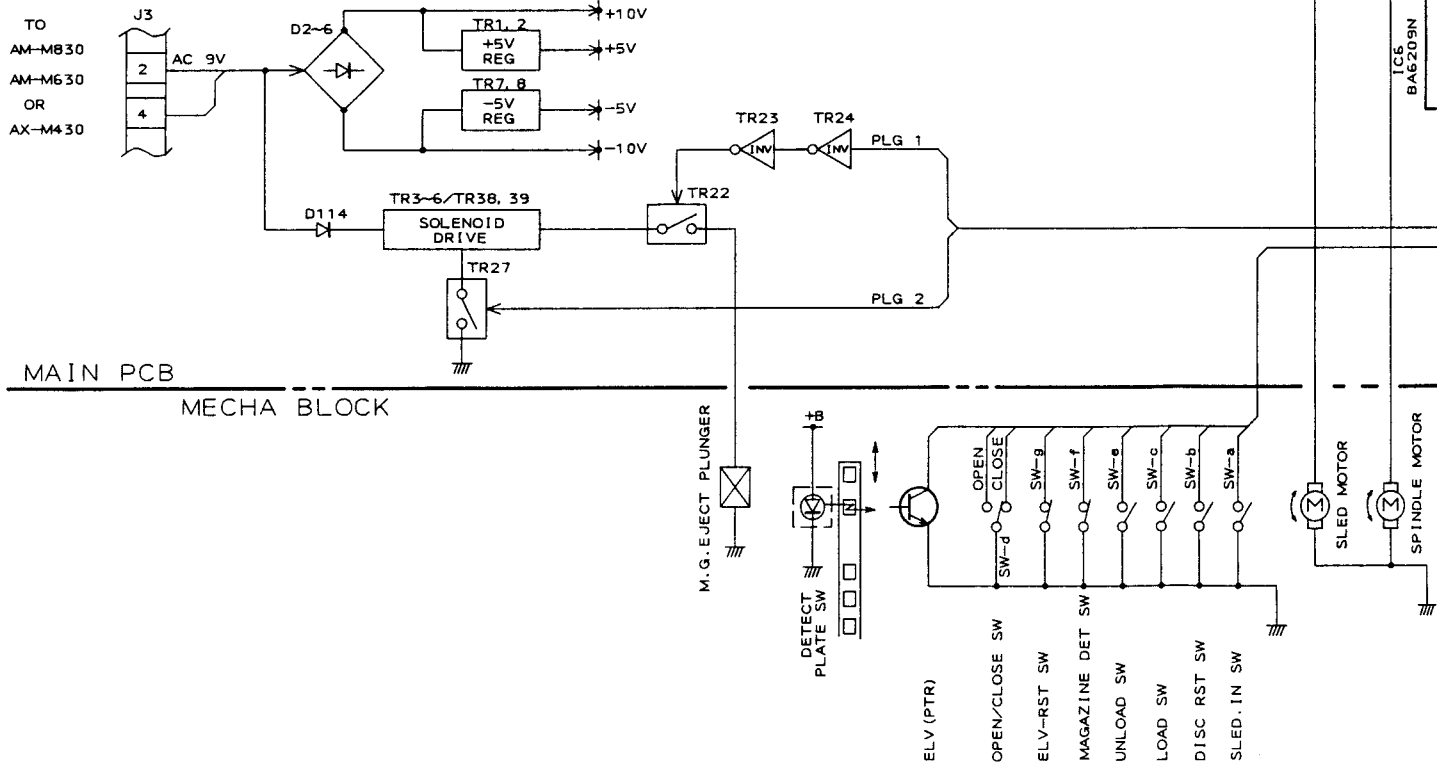
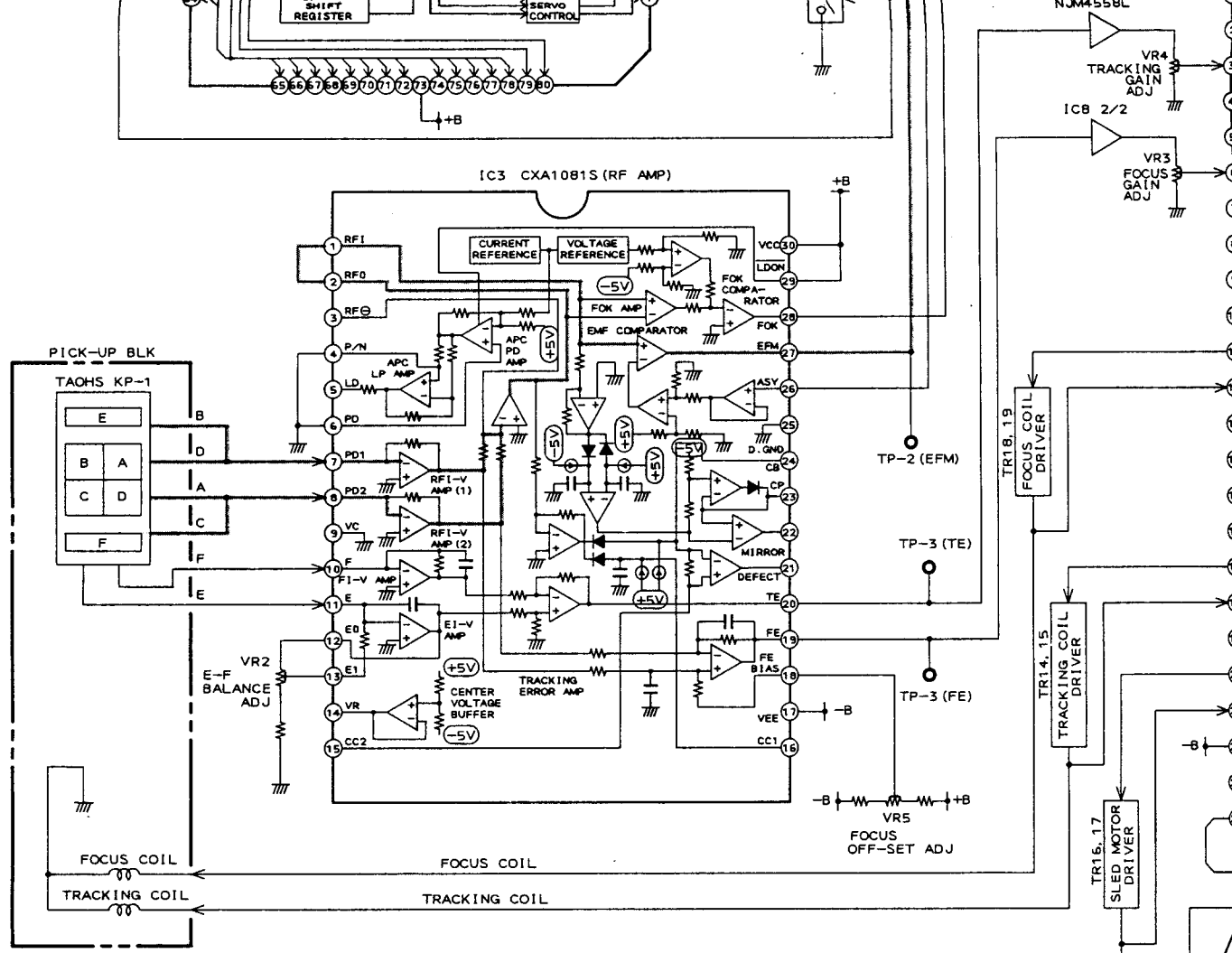

A B C D

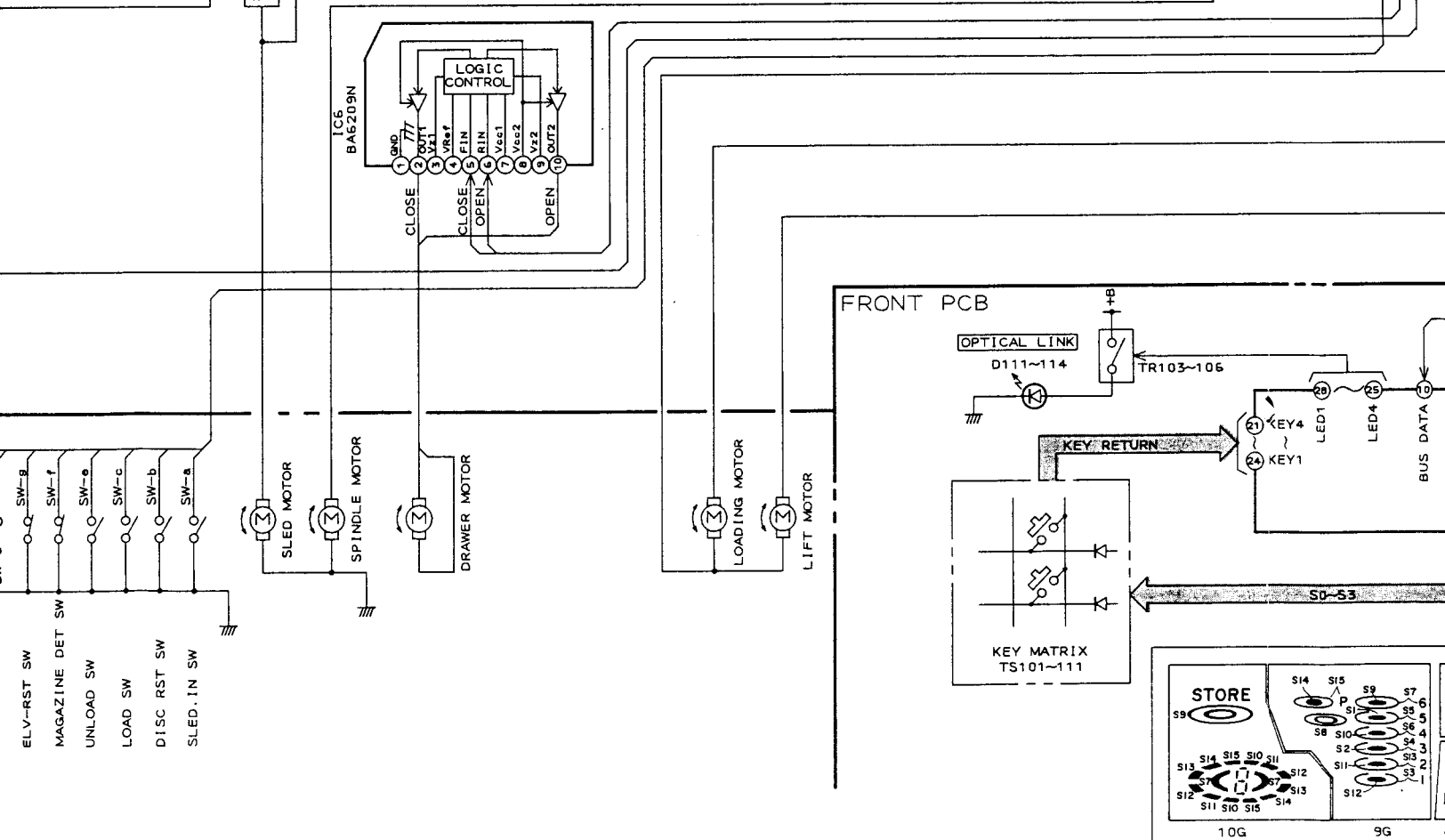
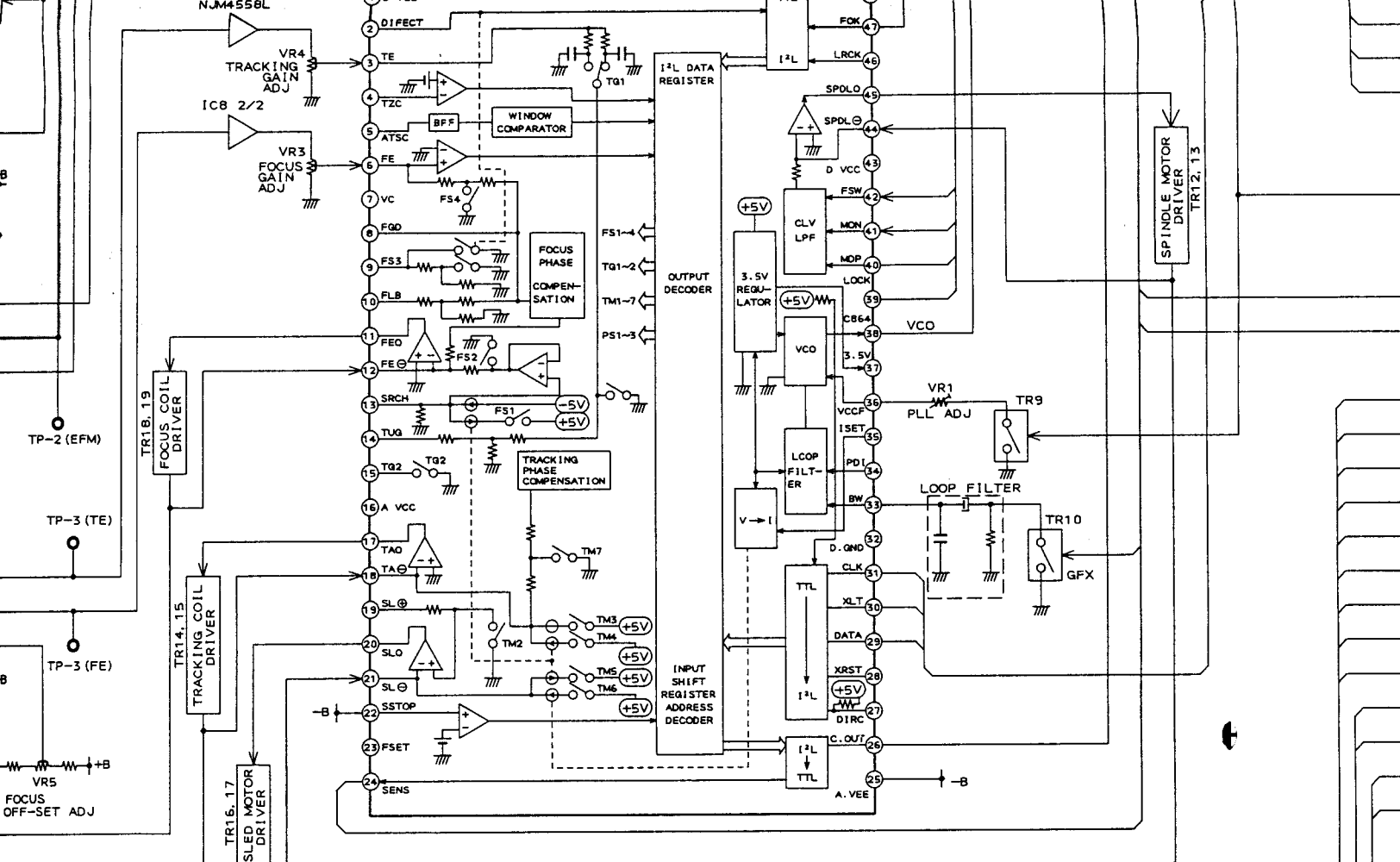

D E F G H

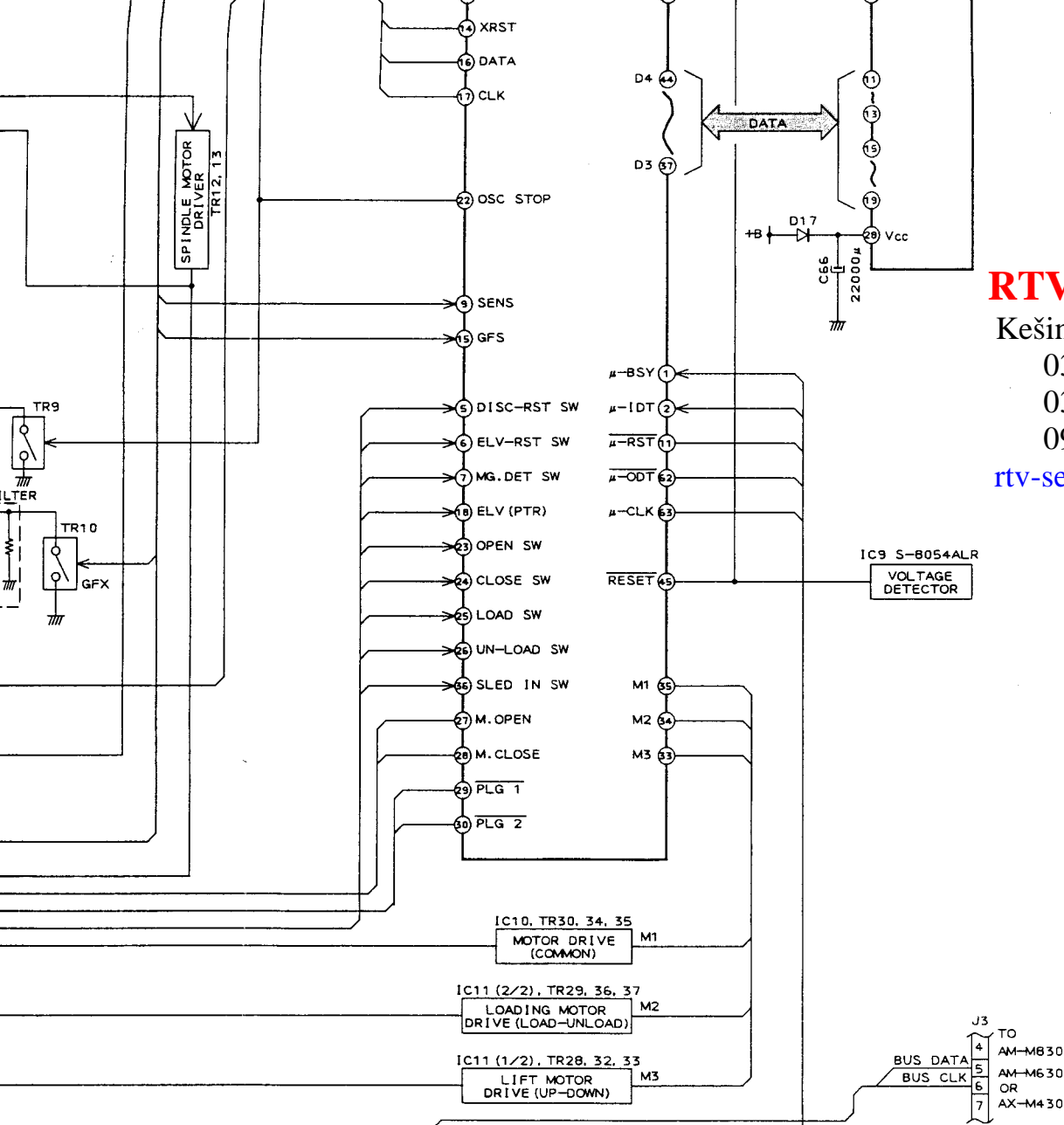

RTV servis Horvat
 Kešinci, 31402 Semeljci
 031-856-139
 031-856-637
 098-788-319
 rtv-servis-horvat@os.tel.hr
 Croatia

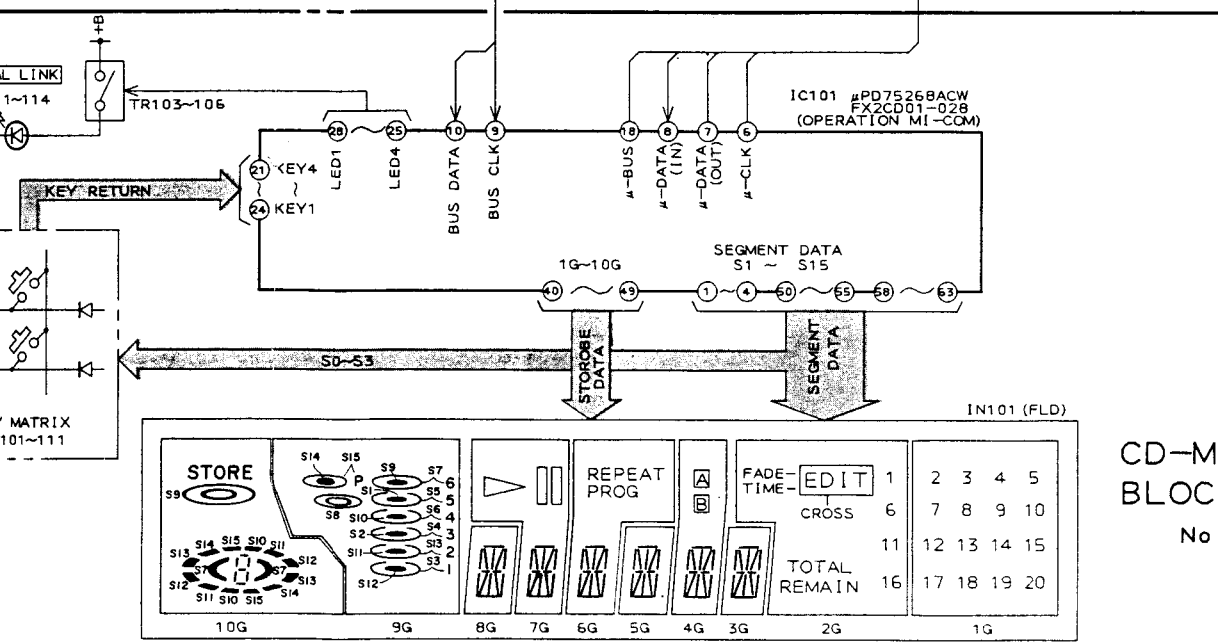

CD-M830M
 BLOCK DIAGRAM
 No. P206551M
 A1

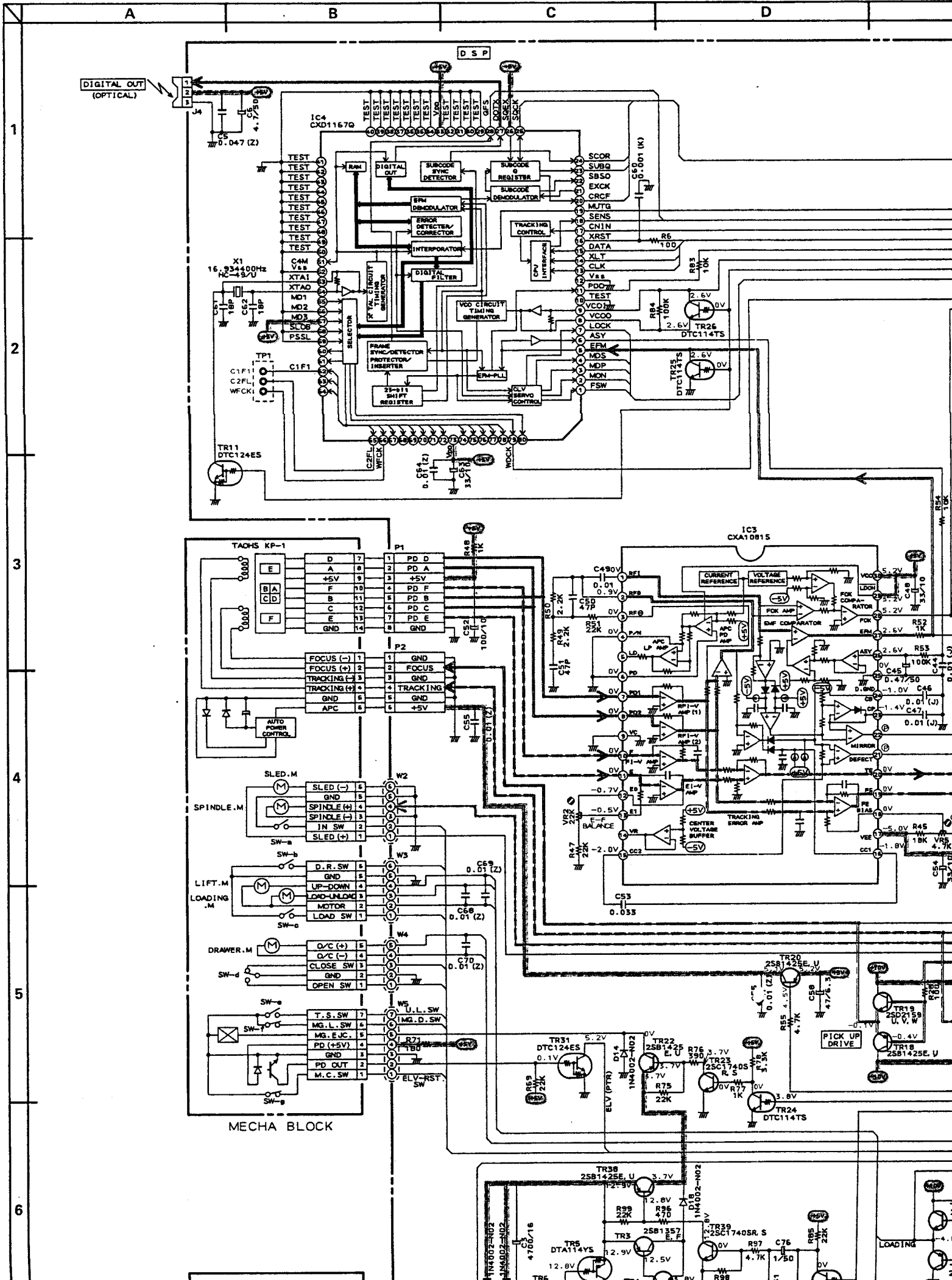

D

E

F

G

H

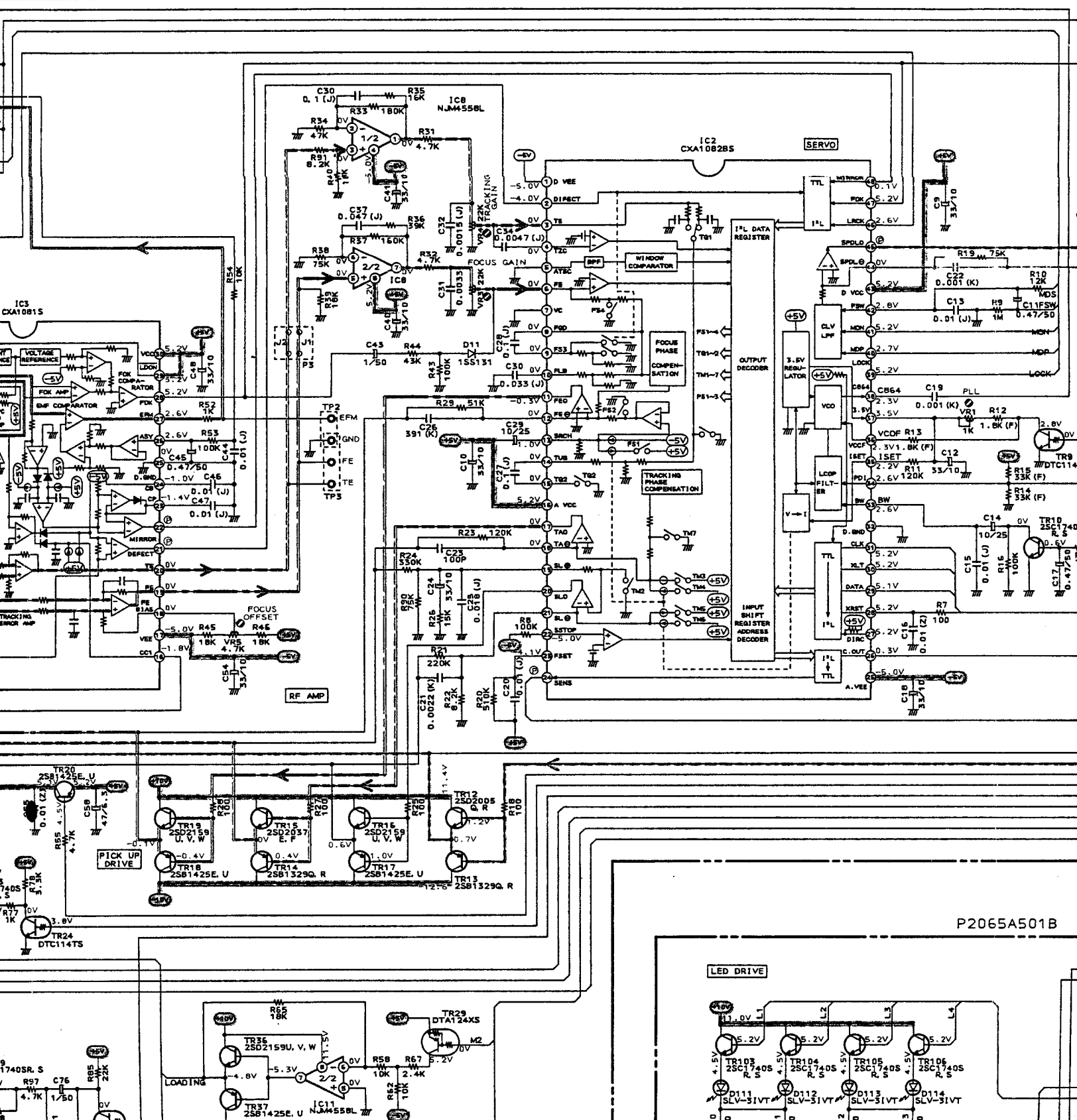

P2065A501B

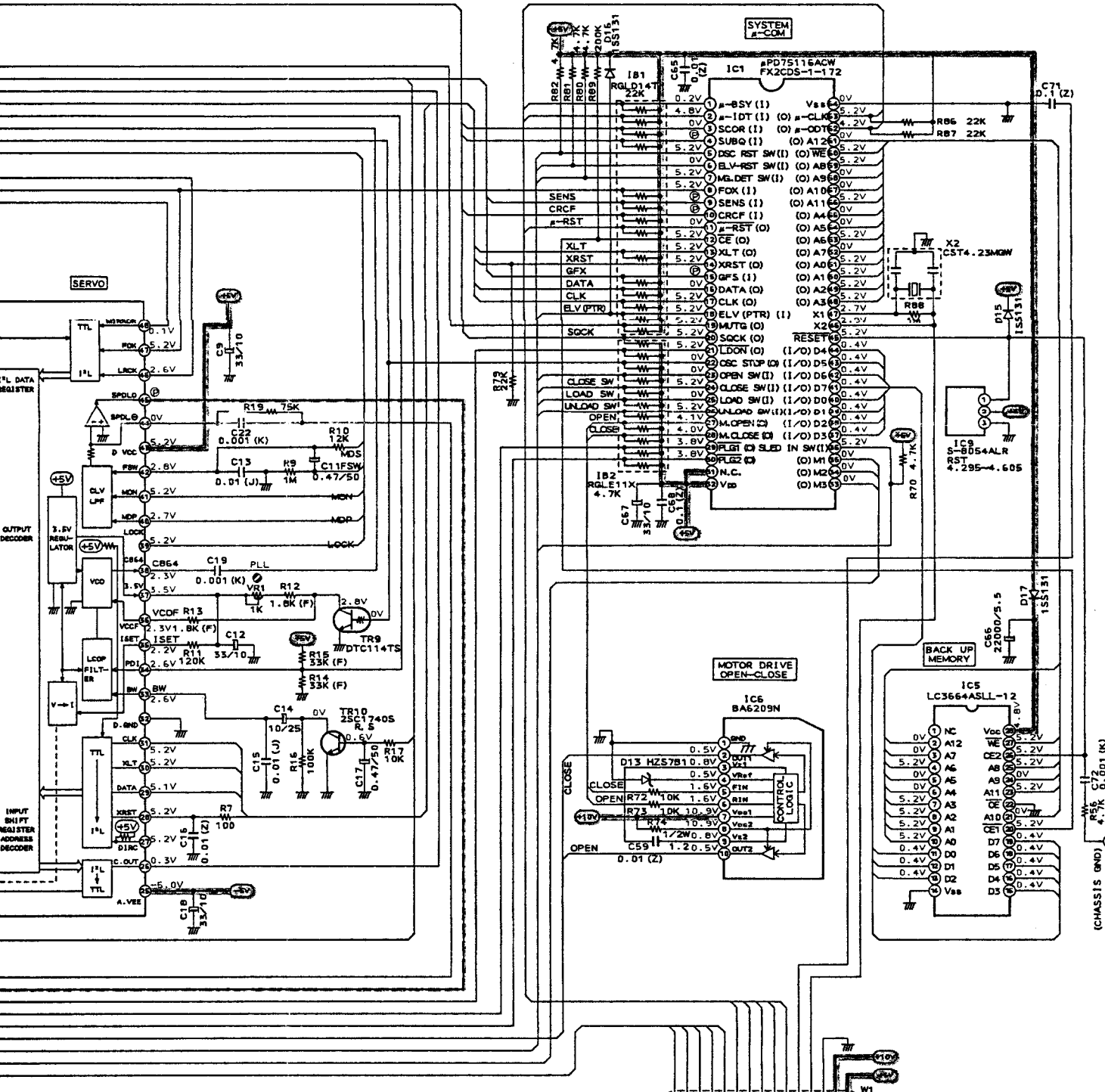

P2065A501B FRONT PCB

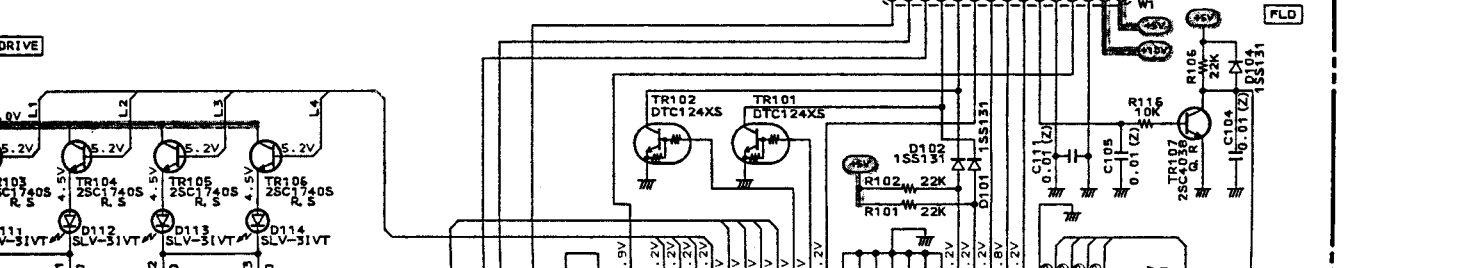

DRIVE

FLD

1

2

3

4

5

6

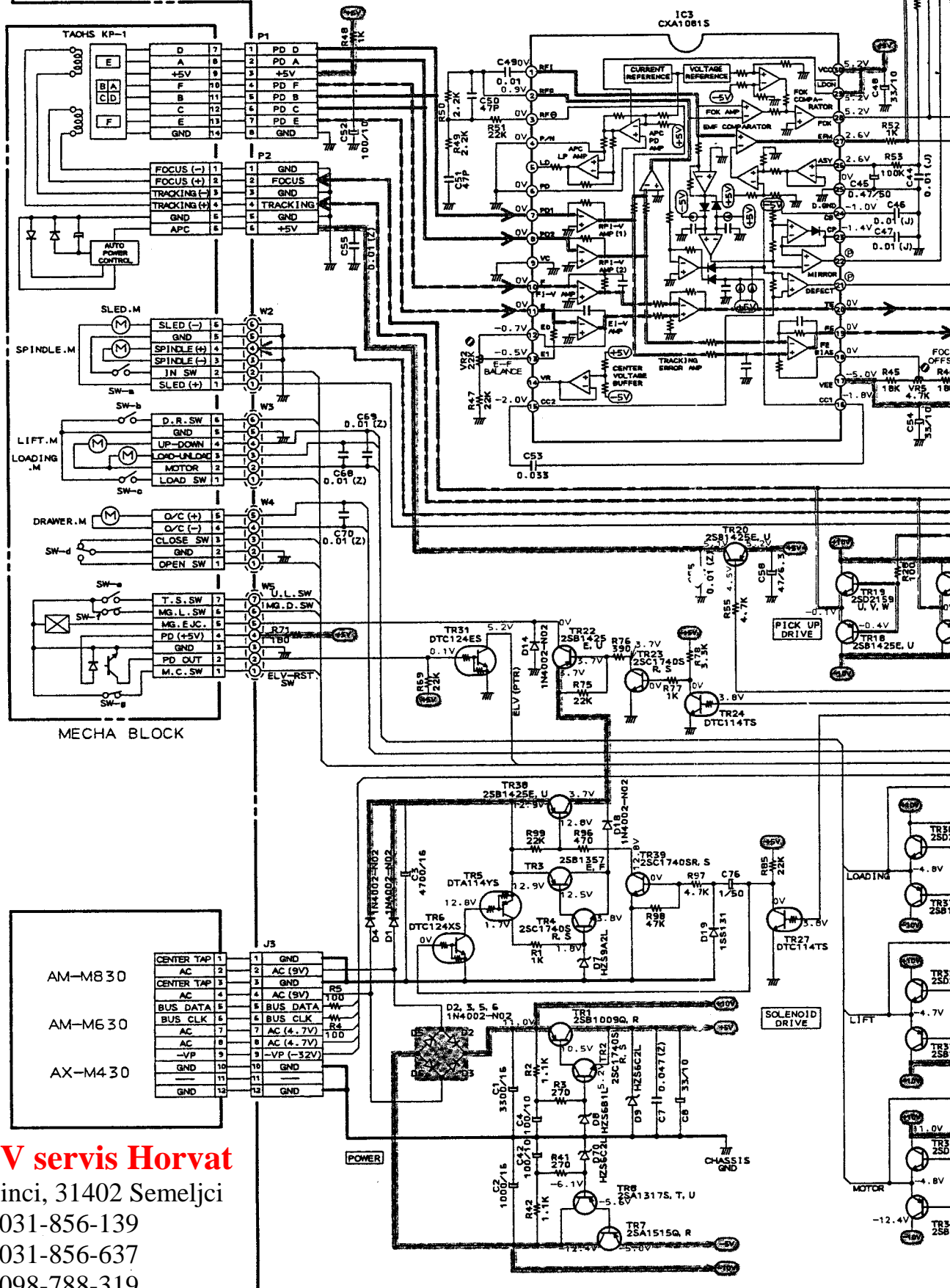

RTV servis Horvat

Kešinci, 31402 Semeljci

031-856-139

031-856-637

098-788-319

rtv-servis-horvat@os.tel.hr

Croatia

- B (POWER SUPPLY) LINE
- SIGNAL LINE
- - - TRACKING SERVO LINE
- - - FOCUS SERVO LINE
- - - SPINDLE MOTOR DRIVE LINE

INDICATED VOLTAGES WERE MEASURED DURING PLAY MODE.

3

4

5

6

7

8

A

B

C

D

4

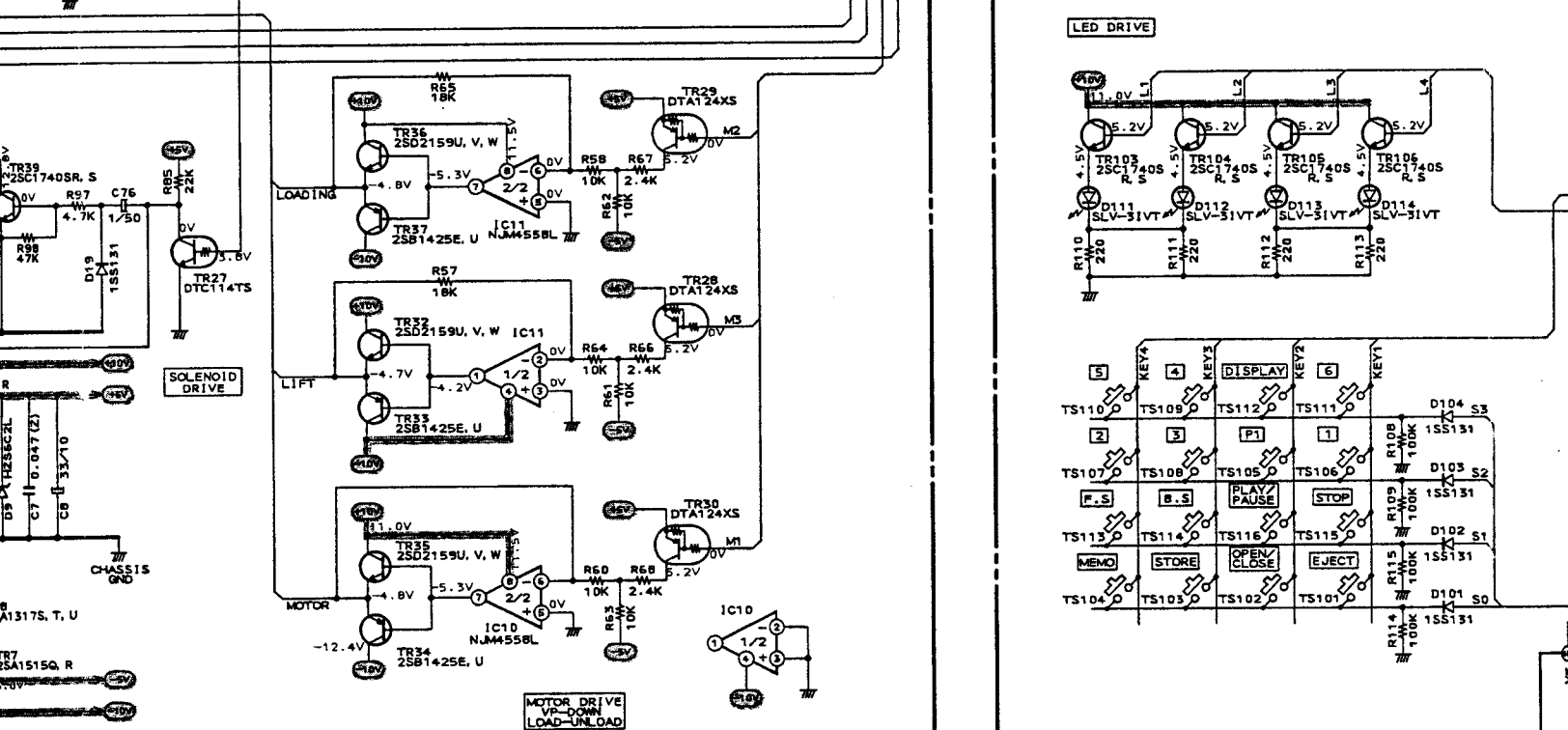
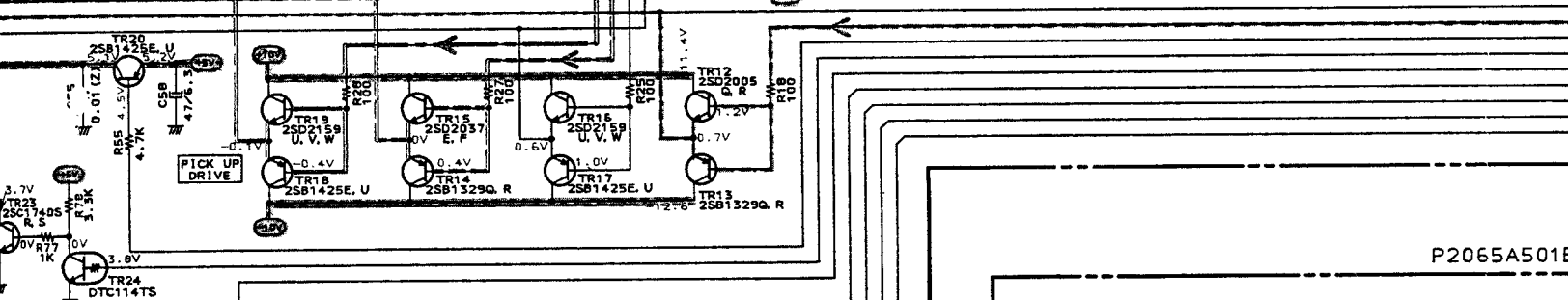
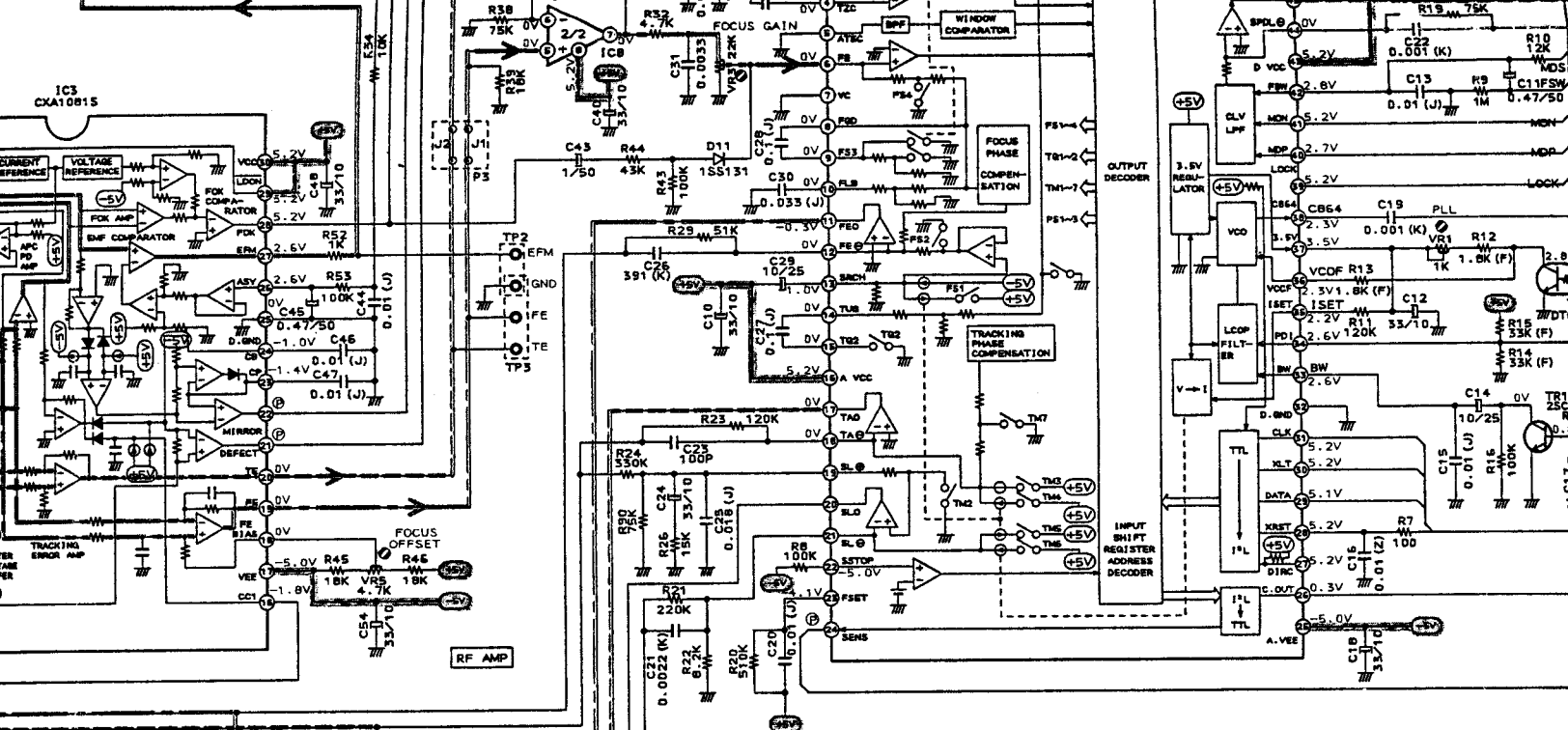

MAIN PCB P2065A501A

INDICATED VOLTAGES WERE MEASURED DURING PLAY MODE.

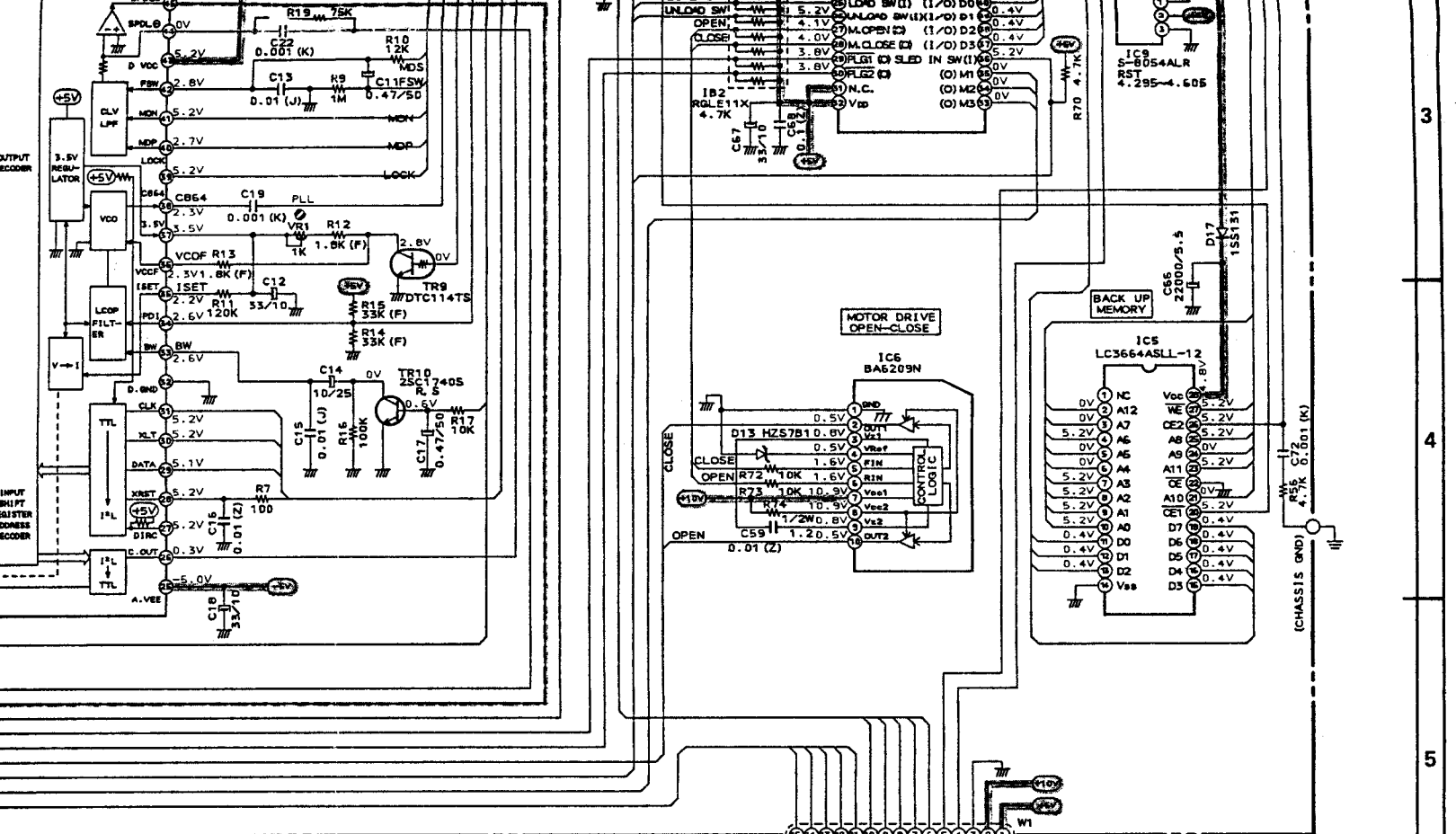

P2065A501B FRONT PCB

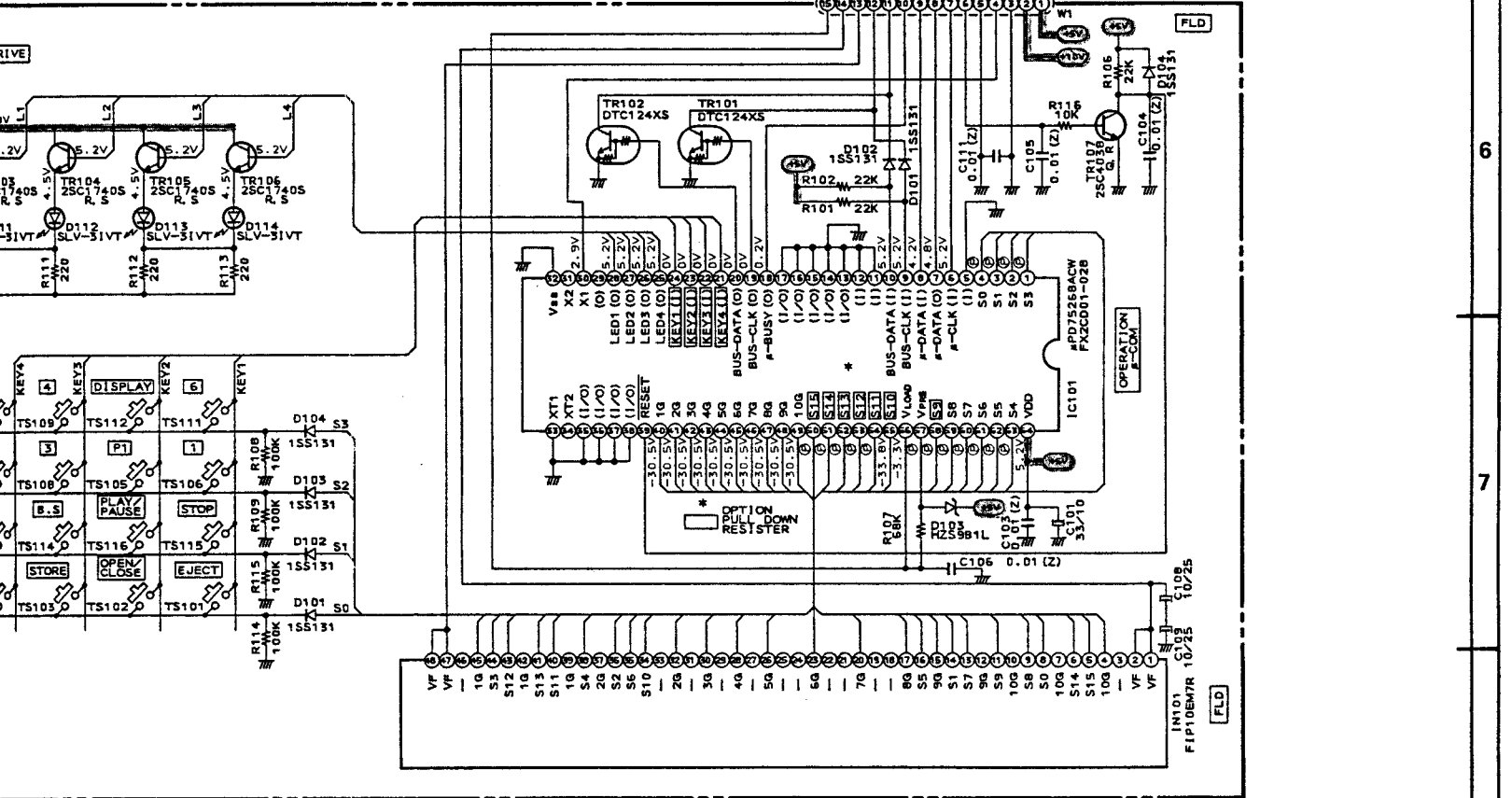

CD-M830M
SCHEMATIC DIAGRAM
No. P206501M
A01

FINAL ASSEMBLY BLOCK

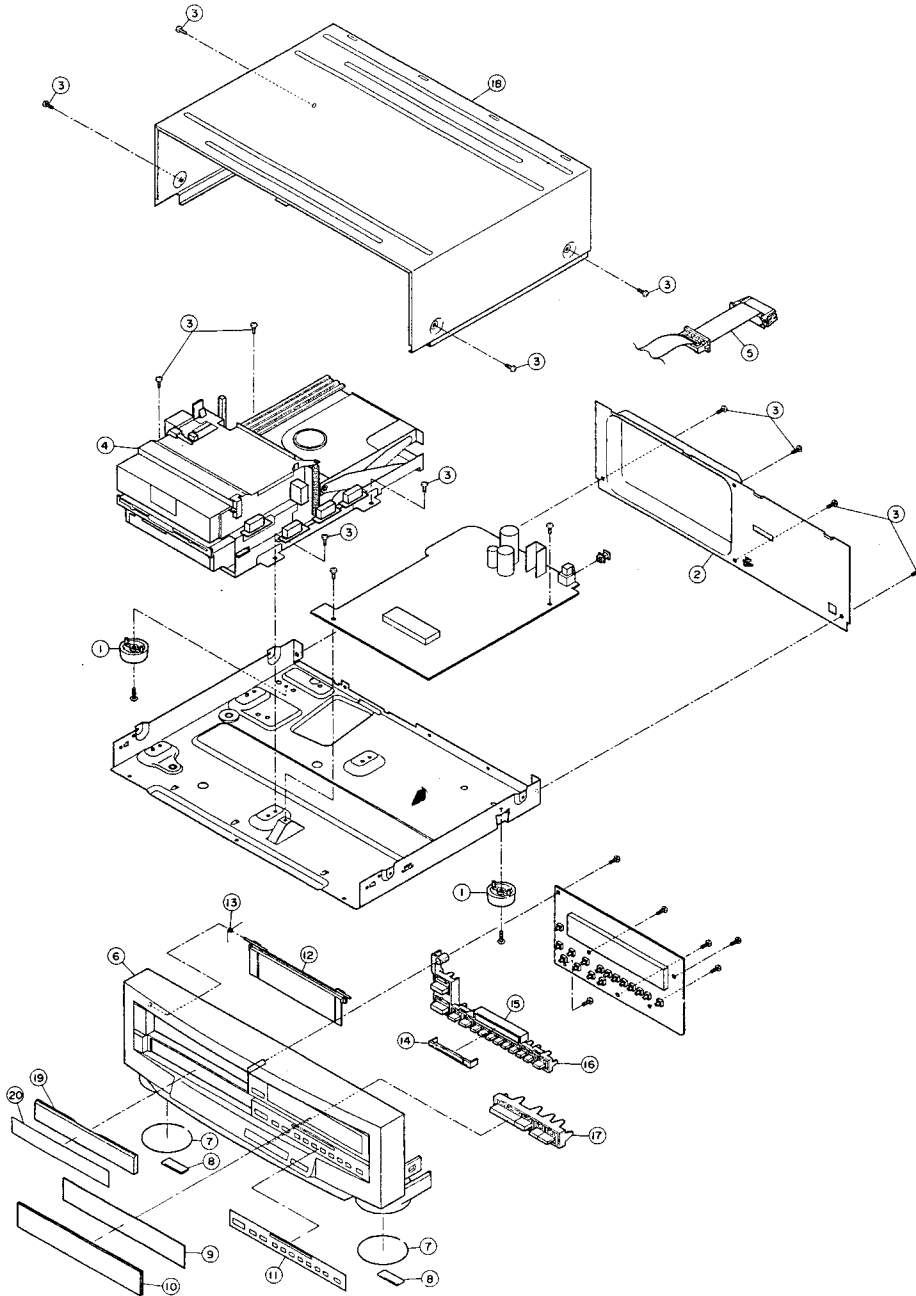

6. FINAL ASSEMBLY BLOCK

Ref.No.	Part No.	Description
1	SA-394127M1	FOOT REAR
2A	SP-405024M	PANEL REAR CD-M830M (U) [U]
2B	SP-405025M	PANEL REAR CD-M830M (E) [E.V]
3	ZS-308846	T2BR30X08STL BZN PROJECTION
4	BB-405228J	MECHA CD CHANGEER P2065
5	EW-394419J	WIRE ASSY P2059 12P
6	SP-404946M	PANEL FRONT
7	SZ-401762M	RING FOOT
8	SA-394136M	CUSHION FOOT
9	SE-404950M	FILTER FLD
10	SE-404956M	WINDOW FLD
11	SE-404955M1	WINDOW OPTICAL
12	SE-404953M	MASK MAGAZIN
13	ZG-404949M	SP TORSION MASK
14	SE-394119M	LENS OPTICAL
15	SE-394121M	REFLECTOR OPTICAL
16	SK-404957M	BUTTON NUMBER
17	SK-404952M	BUTTON OPERATION

Ref.No.	Part No.	Description
18	SP-405822M	COVER UPPER CHG
19	SP-404951M	PANEL TRAY
20	SE-404947M	WINDOW TRAY

NOTE:

Parts will not be supplied if they are not listed in the parts list, even if they appear on the assembling illustrations with reference No.

7. ACCESSORY

Ref.No.	Part No.	Description
1	AX-385911J	CORD P2187-60A
2	AX-405229J	CD MAGAZINE CASE CX-MT003E

ABBREVIATIONS (COMPACT DISC)

ABBREVIATION	EXPLANATION	ABBREVIATION	EXPLANATION
A-D	Analog to Digital (Convertor)	Mb	Mega Bits
ADC	Analog to Digital (Convertor)	MDA	Motor Drive Amplifier
BCD	Binary Code Decimal	MFM	Modified Frequency Modulation
BPI	Bits per Inch	MM	Mono-stable Multivibrator
CD	Compact Disc	M ² FM	Modified Modified Frequency Modulation
CIRC	Cross Interleaving & Reed Solomon Coding	MOD2	Modulo 2 (Addition)
CLV	Constant Linear Velocity	MP	Microprocessor
CP	Clock Pulses	MSB	Most Significant Bit
CRCC	Cyclic Redundancy Check Codes	NA	Numerical Aperture
D Level	Decision Level	NRZ	Non Return to Zero
D-A	Digital to Analog (Convertor)	NRZ-1	Non Return to Zero Inverted
DAC	Digital to Analog (Convertor)	P	Parity Data
DAD	Digital Audio Disc	PAM	Pulse Amplitude Modulation
DEM	Dynamic Element Matching	PCM	Pulse Code Modulation
DPD	Differential Phase Detection	PD	Phase Detector
DSV	Digital Sum Value	PE	Phase Encode
EFM	Eight to fourteen Modulation	PLL	Phase Locked Loop
EX-OR	EXclusive OR	PNM	Pulse Number Modulation
FCI	Flux Changes per Inch	PPM	Pulse Phase Modulation
FIR	Finite Impulse Response	PWM	Pulse Width Modulation
FP	Front Pulse	Q	Parity Data
FPG	Front Pulse Gate	R, R ₁ , R ₂ , etc.	Data for Right Channel
f	Frequency of Sampling	RAM	Random Access Memory
GF	Galois Field	RPG	Rear Pulse Gate
H & V (Parity)	Horizontal & Vertical	SCOOP	Self Coupled Optical Pick-up
IIR	Infinite Impulse Response	S & H	Sample & Hold
kb	Kilo Bits	S/N	Signal to Noise Ratio
L, L ₁ , L ₂ , etc.	Data for Left Channel	SSG	Standard Signal Generator
LPF	Low Pass Filter	SYSCON	SYStem CONtrol
LSB	Least Significant Bit		

RTV servis Horvat

Kešinci, 31402 Semeljci

031-856-139

031-856-637

098-788-319

rtv-servis-horvat@os.tel.hr

Croatia

AKAI ELECTRIC CO., LTD.

12-14, 2-Chome, Higashi-Kojiya, Ohta-ku, Tokyo, Japan

SERVICE DEPARTMENT TEL:Tokyo (3745)9884 TELEX:J26261

Printed No. 910621-A1-2414

Printed Date July 31, 1991

Printed by: Schaltungsdienst Lange, Berlin (GERMANY)