

AKAI SERVICE MANUAL

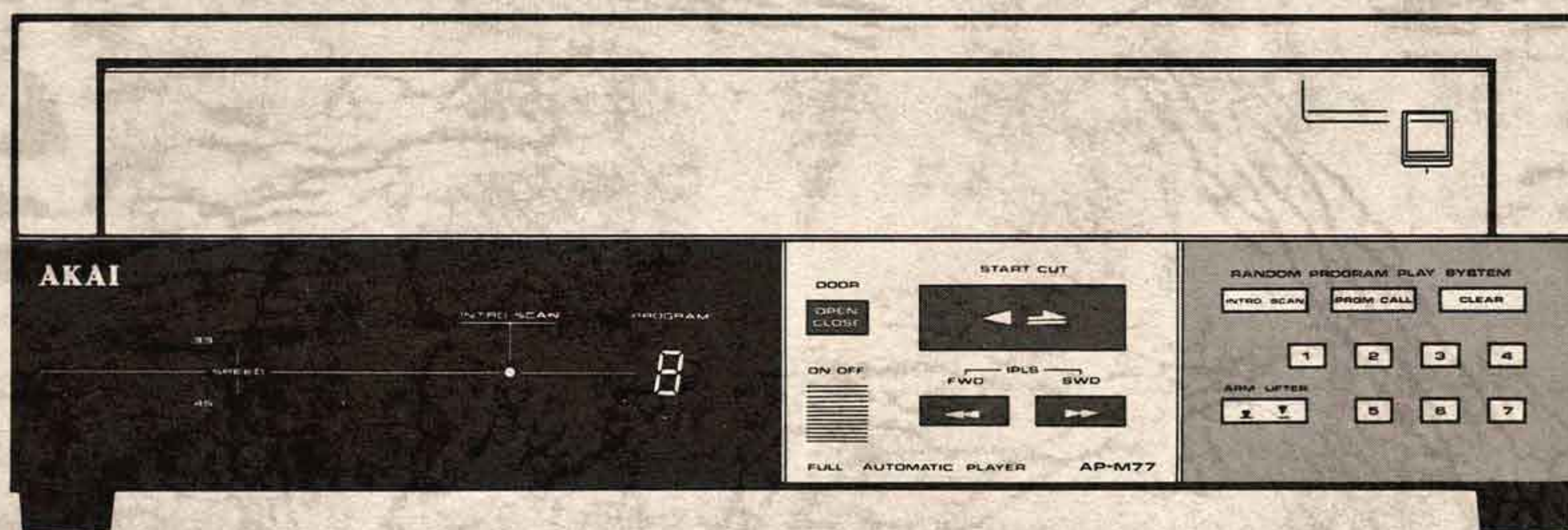

FULL AUTOMATIC PLAYER

MODEL **AP-M77**

SAFETY INSTRUCTIONS

SAFETY CHECK AFTER SERVICING

Confirm the specified insulation resistance between power cord plug prongs and externally exposed parts of the set is greater than 10 Mohms, but for equipment with external antenna terminals (tuner, receiver, etc.) and is intended for **C** or **A**, specified insulation resistance should be more than 2.2 Mohms (ground terminals, microphone jacks, headphone jacks, line-in-out jacks etc.)

PRECAUTIONS DURING SERVICING

1. Parts identified by the \triangle symbol parts are critical for safety.
Replace only with parts number specified.
2. In addition to safety, other parts and assemblies are specified for conformance with such regulations as those applying to spurious radiation. These must also be replaced only with specified replacements.
Examples: RF converters, tuner units, antenna selector switches, RF cables, noise blocking capacitors, noise blocking filters, etc.
3. Use specified internal wiring. Note especially:
 - 1) Wires covered with PVC tubing
 - 2) Double insulated wires
 - 3) High voltage leads
4. Use specified insulating materials for hazardous live parts. Note especially:
 - 1) Insulation Tape
 - 2) PVC tubing
 - 3) Spacers (Insulating Barriers)
 - 4) Insulation sheets for transistors
 - 5) Plastic screws for fixing microswitch (especially in turntable)
5. When replacing AC primary side components (transformers, power cords, noise blocking capacitors, etc.), wrap ends of wires securely about the terminals before soldering.

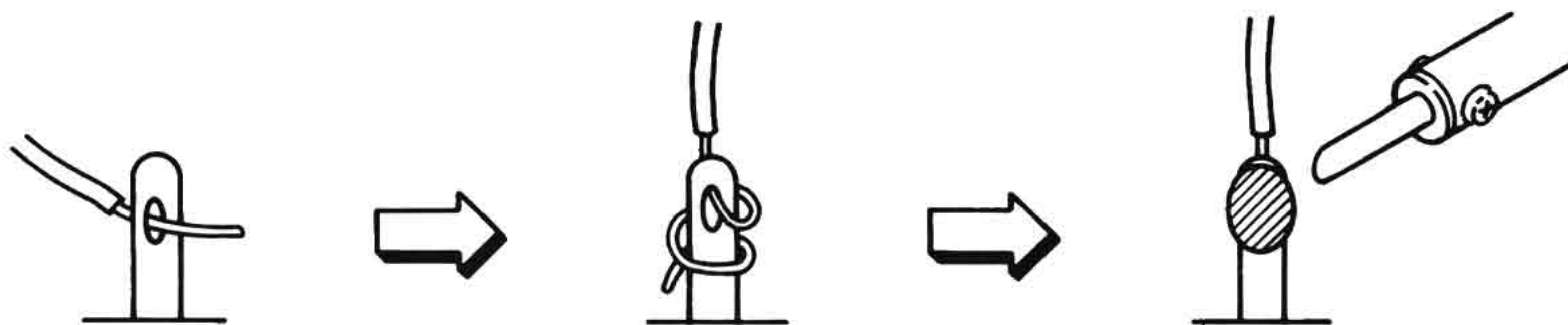

6. Observe that wires do not contact heat producing parts (heatsinks, oxide metal film resistors, fusible resistors, etc.).
7. Check that replaced wires do not contact sharp edged or pointed parts.
8. Also check areas surrounding repaired locations.
9. Use care that foreign objects (screws, solder droplets, etc.) do not remain inside the set.

VOLTAGE CONVERSION

Each machine is preset at the factory according to its destination, but some machines can be set to 110V–120V or 220V–240V as required. If your machine's voltage can be converted:

Before connecting the power cord or assembling the platter, turn the Voltage Selector located on the top of the cabinet with a screwdriver until the correct voltage is indicated. Models for Japan, USA, Europe, UK and Australia are not equipped with this facility.

NOTE: Cycle conversion is unnecessary since this model employs DC motors.

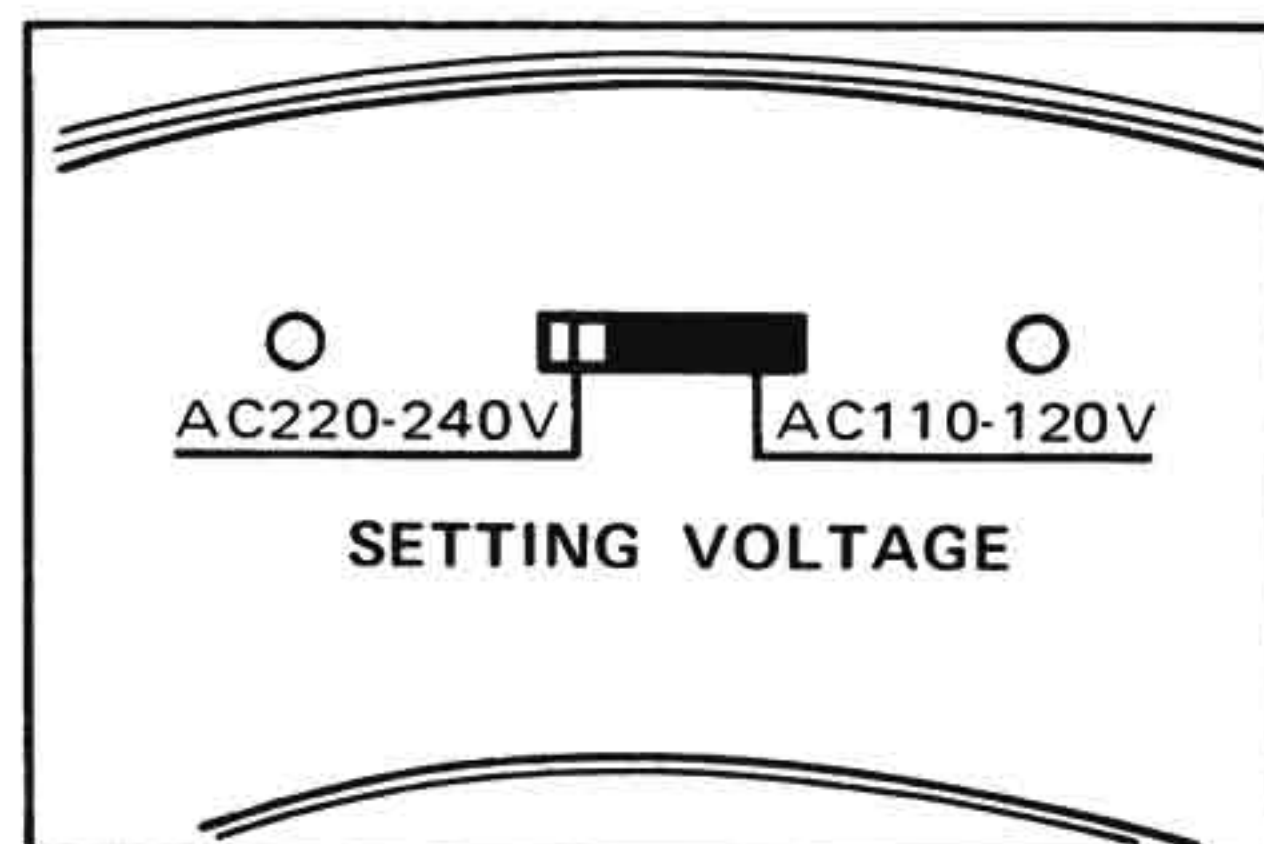

SECTION 1

SERVICE MANUAL

TABLE OF CONTENTS

I.	SPECIFICATIONS	4
II.	DISMANTLING OF UNIT	5
III.	CONTROLS	6
IV.	PRINCIPAL PARTS LOCATION	7
V.	DESCRIPTION OF MISCELLANEOUS OPERATIONS	9
	5-1 OUTLINE OF AP-M77 FUNCTIONS	9
	5-2 SPECIFICATION OF VARIOUS KEY OPERATIONS	9
	5-3 SPECIFICATION OF VARIOUS LEDS	12
	5-4 SPECIFICATION OF COMMON BUS	12
	5-5 TIMING OF VARIOUS OPERATIONS	13
VI.	ADJUSTMENTS	19
	6-1 ORDINARY MECHANICAL ADJUSTMENTS	19
	6-2 ELEVATION ARM POSITION ADJUSTMENT	19
	6-3 POSITION SENSOR SENSITIVITY ADJUSTMENT	20
	6-4 OFF-SET VOLTAGE ADJUSTMENT	20
	6-5 TRACKING SENSOR SENSITIVITY ADJUSTMENT	21
	6-6 MUSIC INTERVAL SENSOR SENSITIVITY ADJUSTMENT	21
	6-7 SPEED ADJUSTMENT	21
	6-8 LEAD-IN POSITION ADJUSTMENT	21
	6-9 PLAY SW (SW902) POSITION ADJUSTMENT	22
	6-10 CLOSE CHASSIS (FOR CLOSE SW: SW2 on LIMIT PCB) POSITION ADJUSTMENT	22
VII.	P.C BOARD TITLES AND IDENTIFICATION NUMBERS	22

For basic adjustments, measuring methods, and operating principles, refer to GENERAL TECHNICAL MANUAL.

I. SPECIFICATIONS

TURNTABLE (PLATTER)	Aluminum alloy diecast
DRIVE SYSTEM	Belt drive full automatic
MOTOR	DC servo motor
SPEED	33-1/3 & 45 rpm
WOW & FLUTTER	0.04% (WRMS)
RUMBLE	70 dB (DIN-B)
TOEARM	Linear tracking dynamic balanced type
EFFECTIVE ARM LENGTH	90 mm
ARM LIFTER	Oil damped
OVER HANG	0 mm
CARTRIDGE	VM type
OUTPUT VOLTAGE	3.5 mV
CHANNEL SEPARATION	20 dB
STYLUS	RS-77
OPTIMAL STYLUS PRESSURE	1.25 g (Pre-adjusted)
POWER REQUIREMENTS	100V, 50/60 Hz for Japan 120V, 60 Hz for USA & Canada 220V, 50 Hz for Europe except UK 240V, 50 Hz for UK & Australia 110–120V/220–240V, 50/60 Hz switchable for other countries
POWER CONSUMPTION	15W (A, C, J, U Models)
DIMENSIONS	350(W) × 115(H) × 250(D) mm (13.8 × 4.5 × 9.8 inches)
WEIGHT	6.7 kg (14.7 lbs)

* For improvement purposes, specifications and design are subject to change without notice.

II. DISMANTLING OF UNIT

In case of trouble, etc. necessitating dismantling, please dismantle in the order shown in the photographs. Reassemble in reverse order.

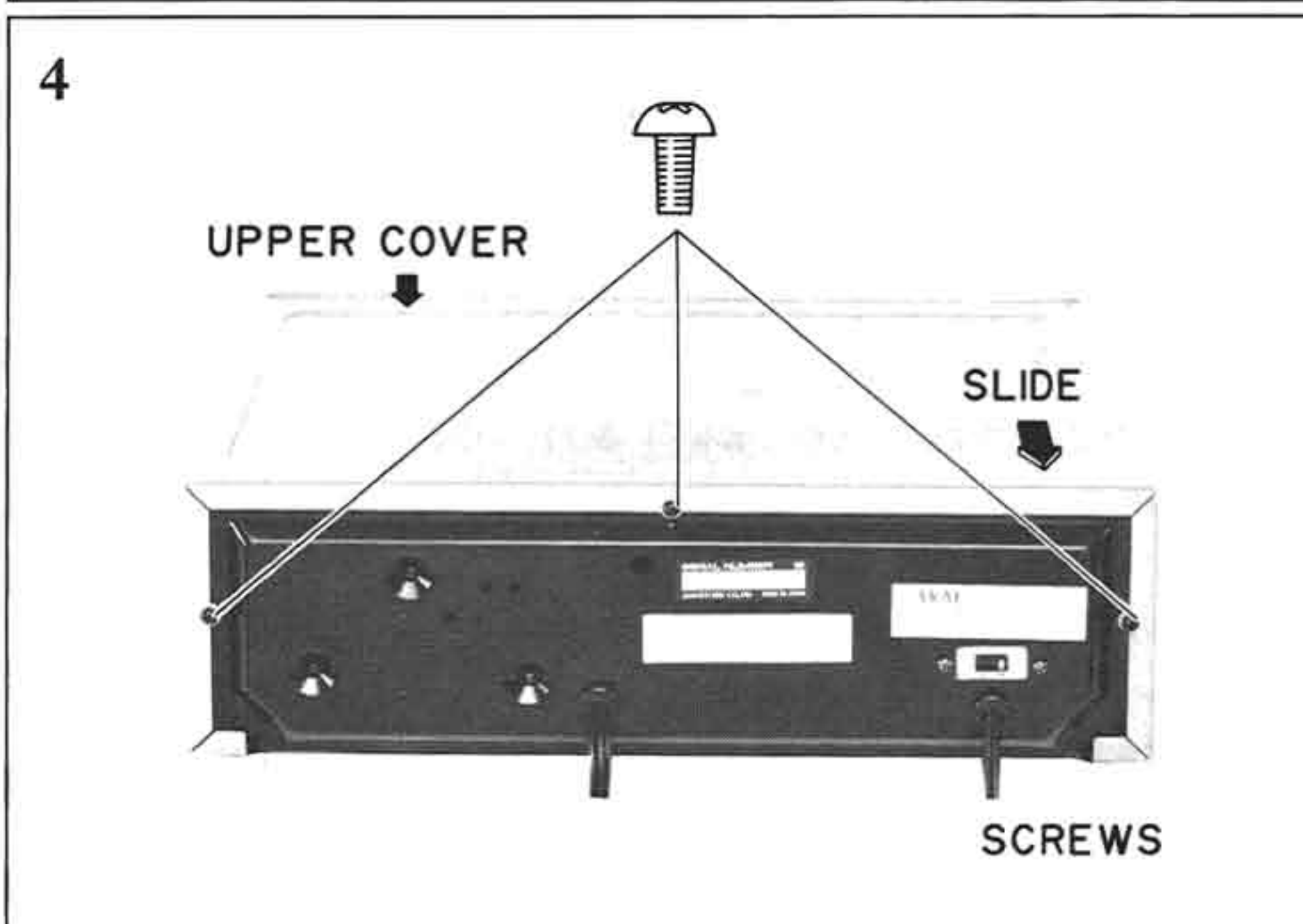
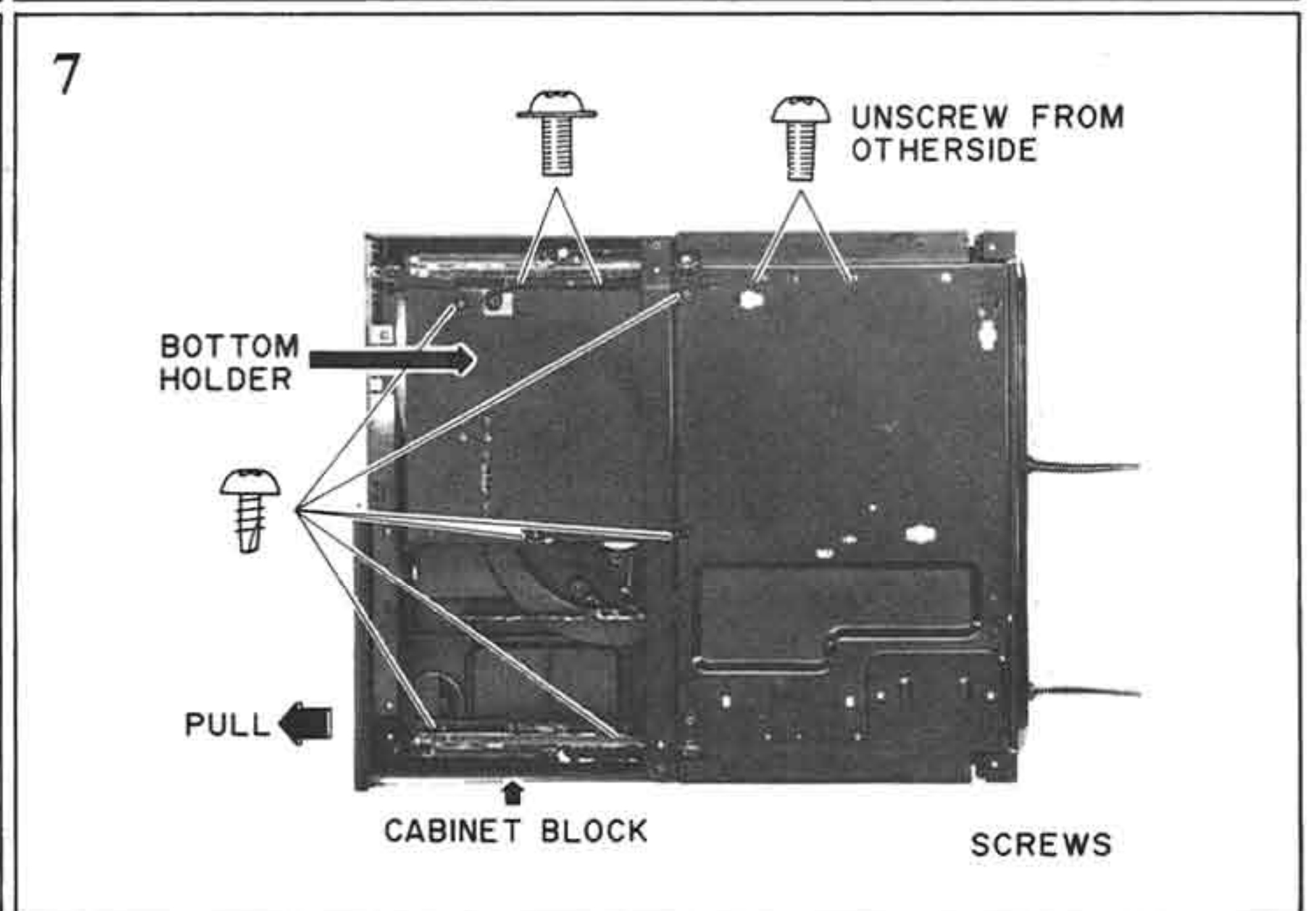
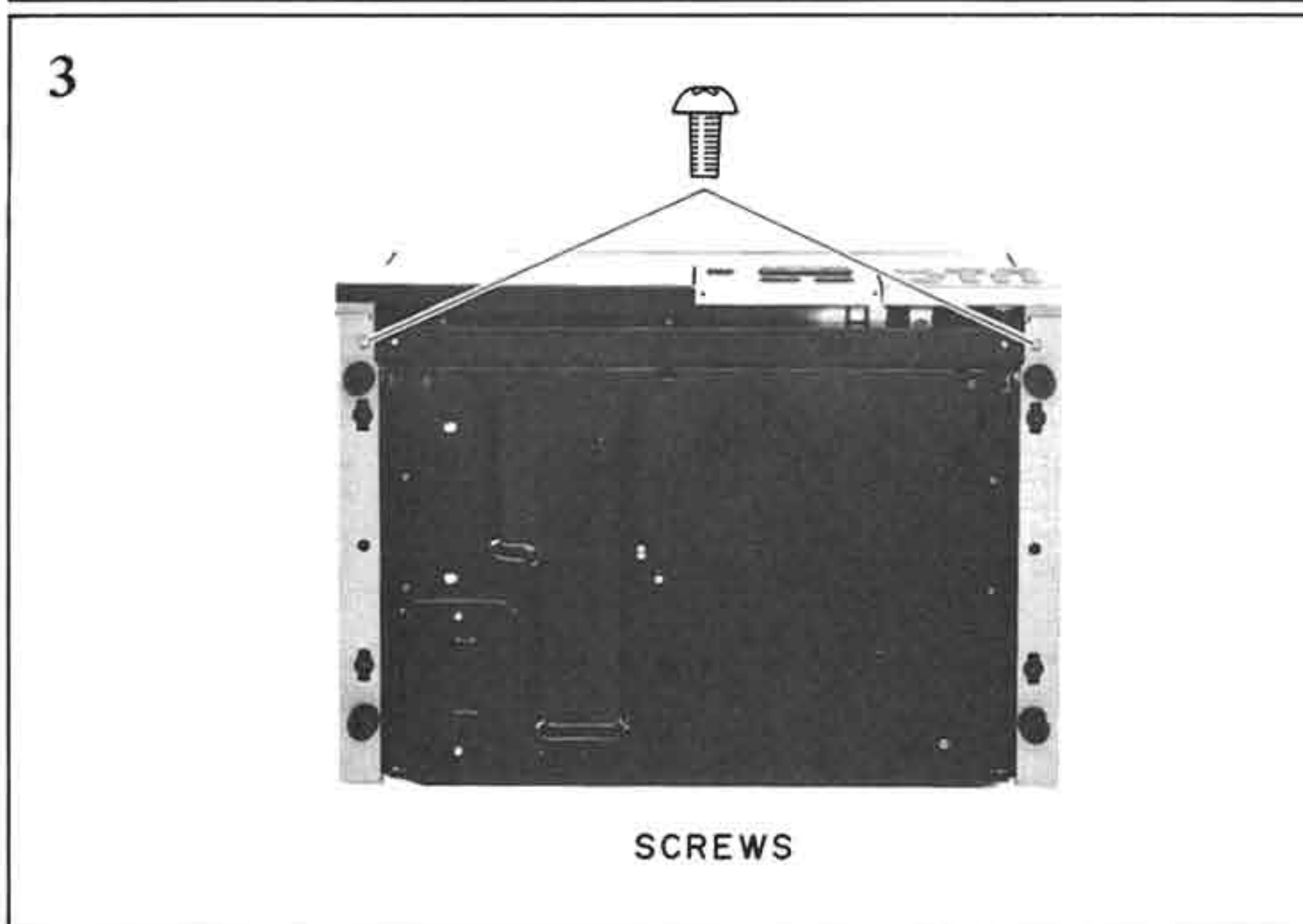
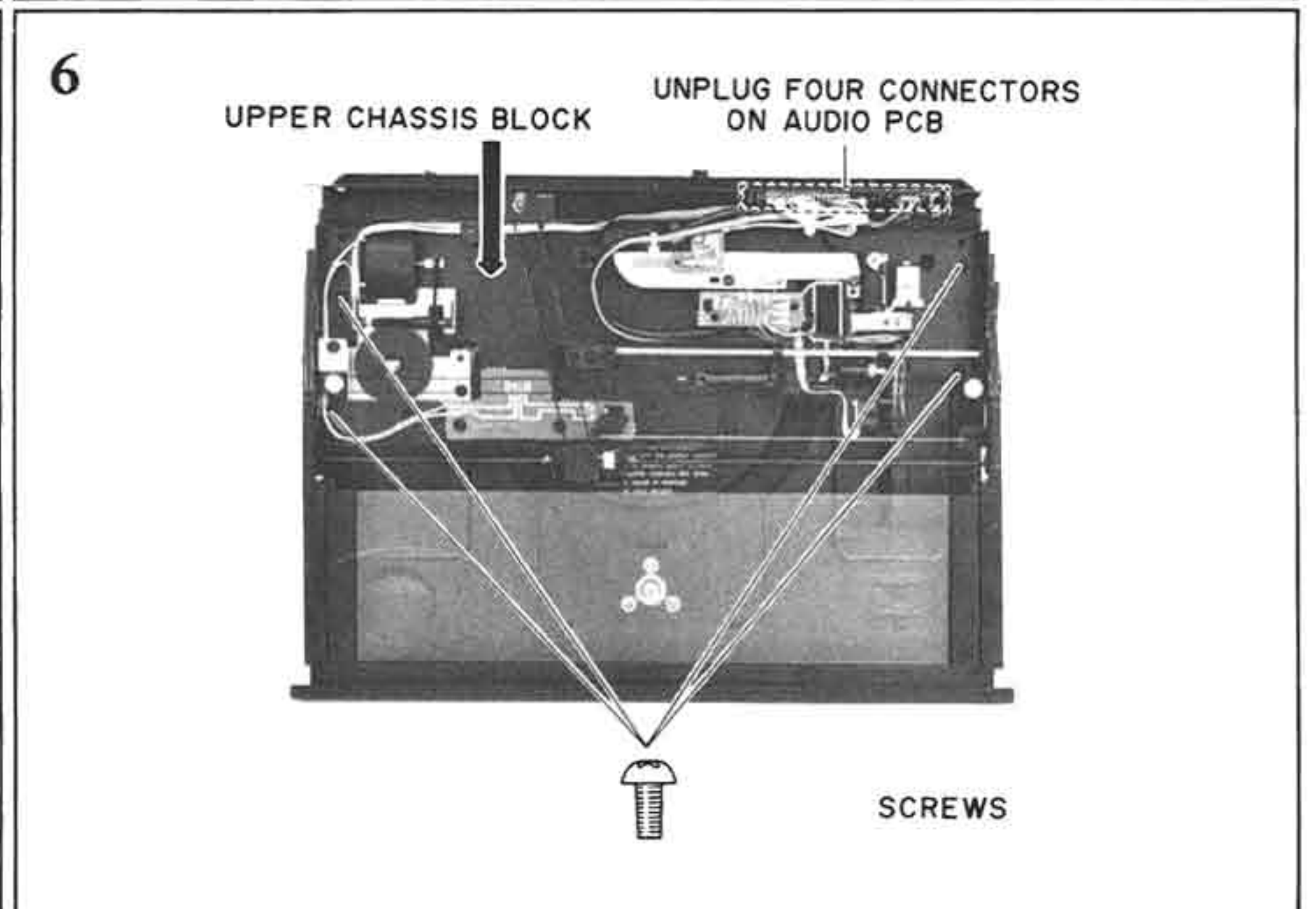
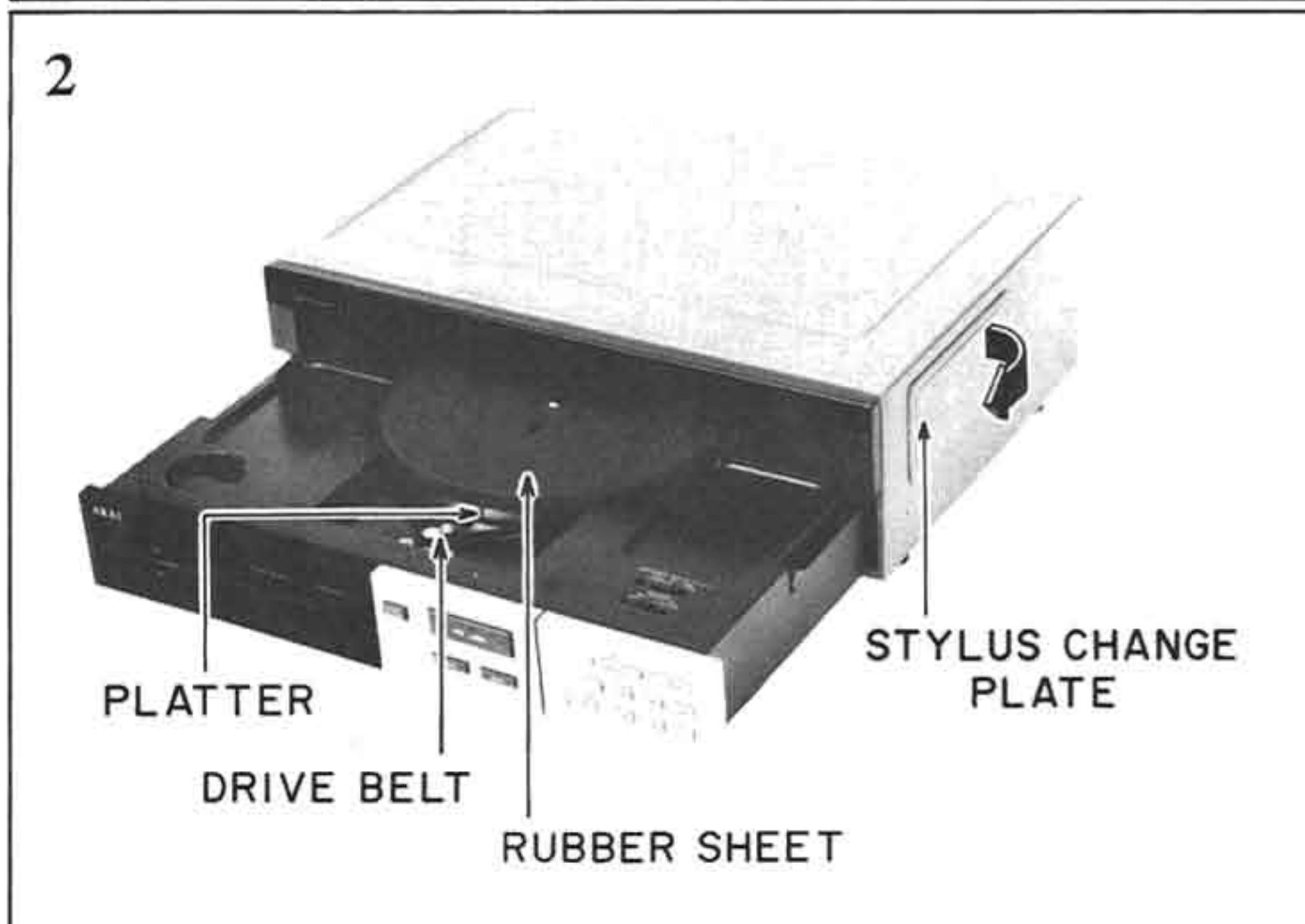
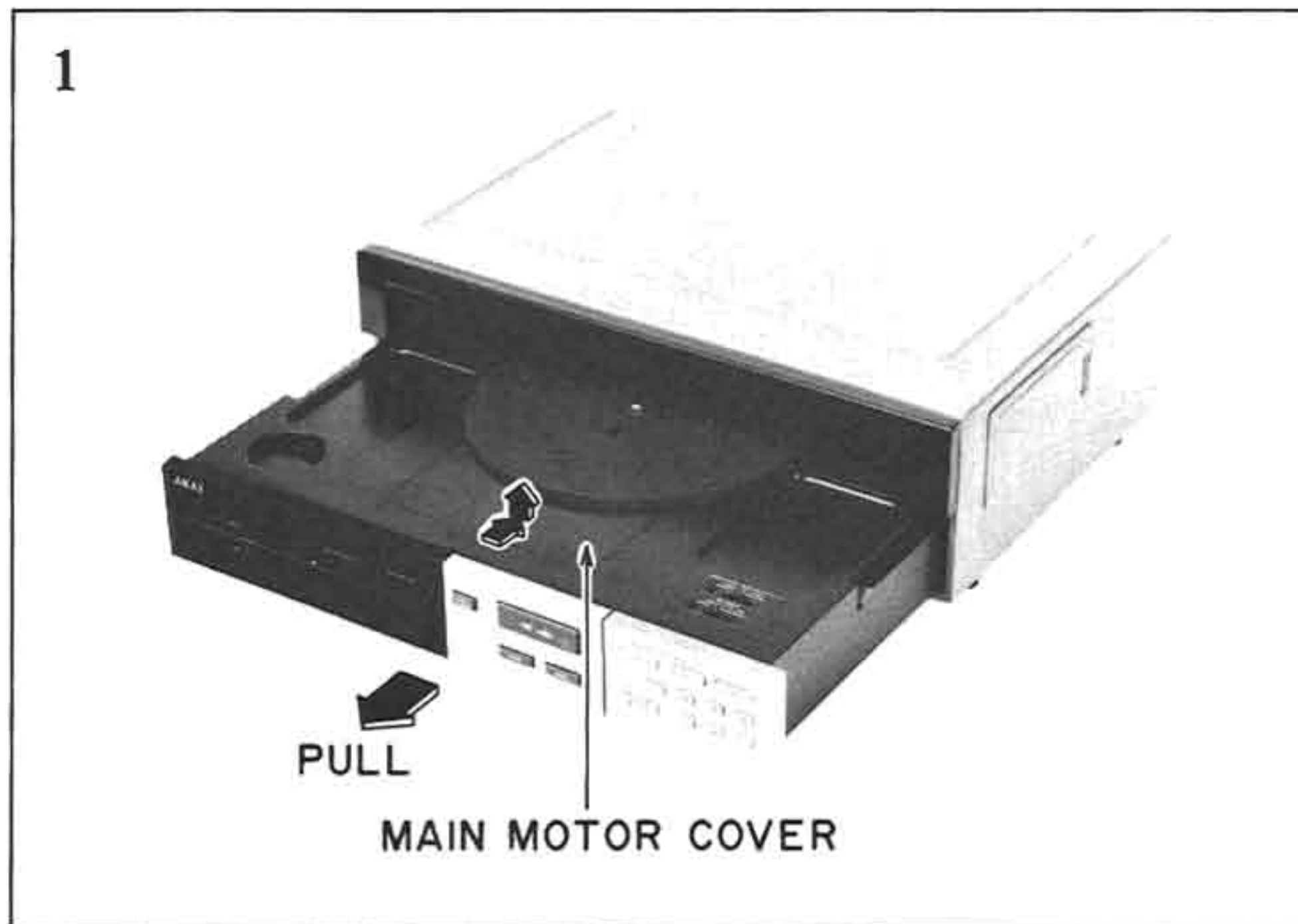

III. CONTROLS

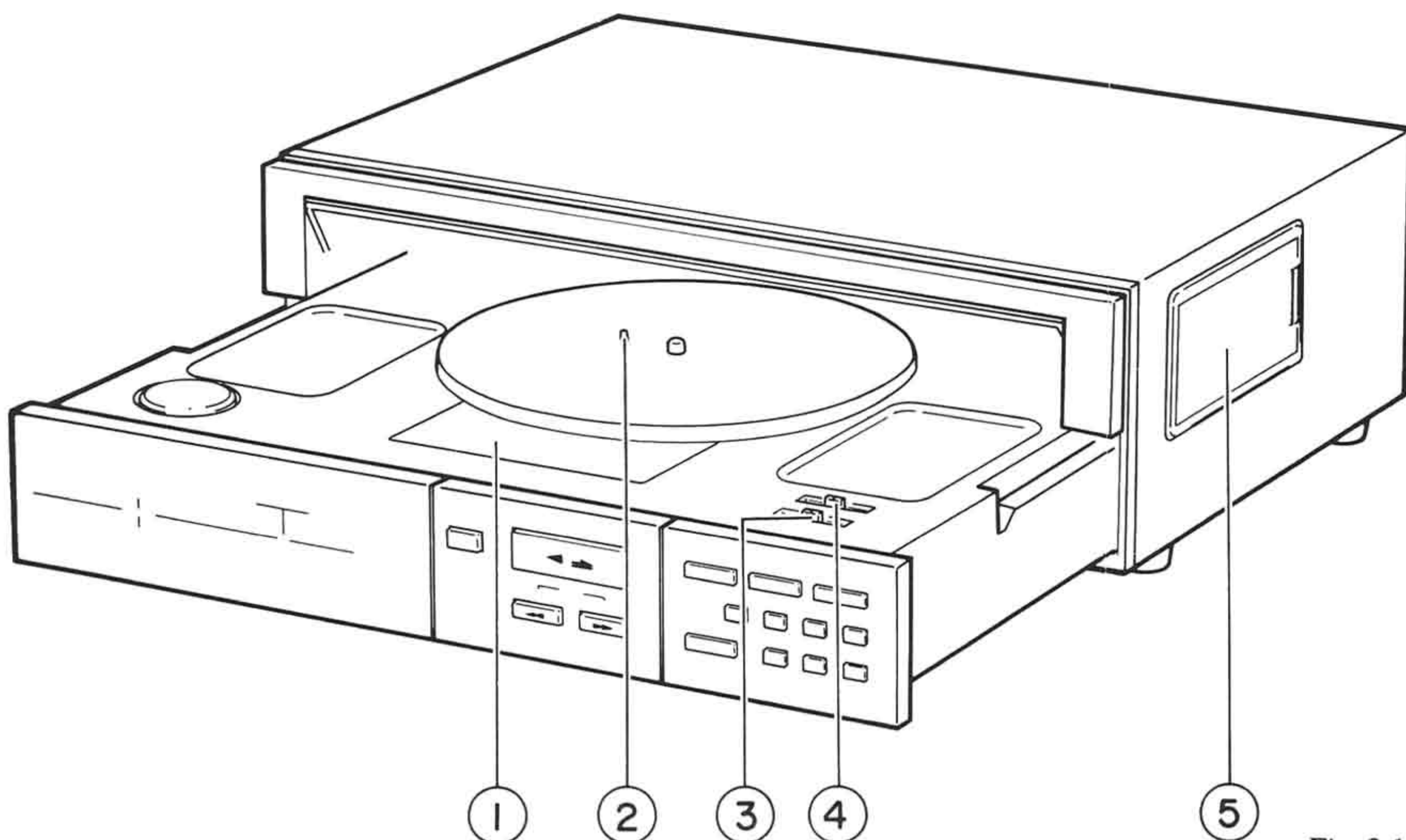

Fig. 3-1

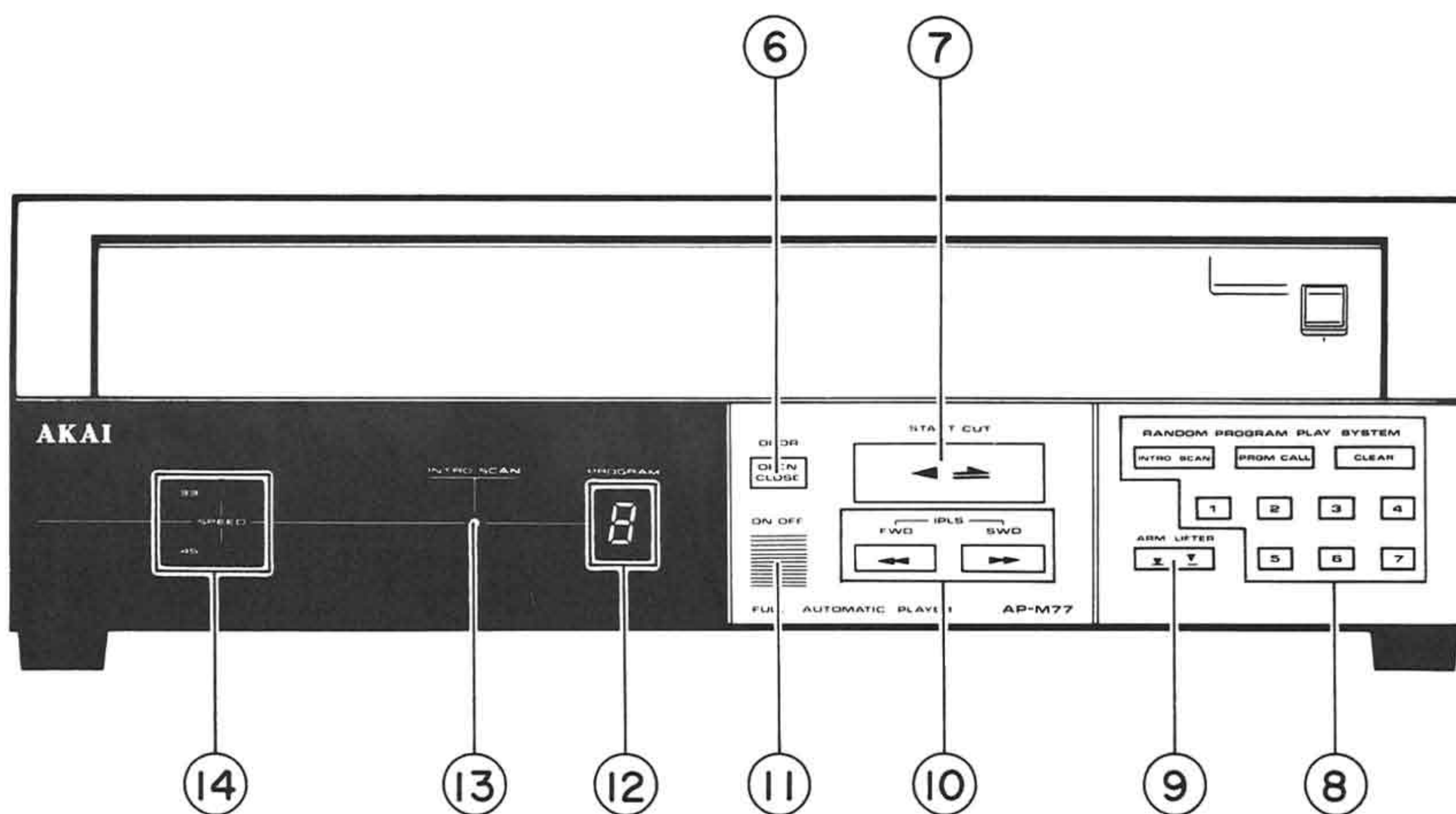

Fig. 3-2

- | | |
|---|---|
| 1. MAIN MOTOR COVER | 9. ARM LIFTER BUTTON
UP (▼), DOWN (▼) |
| 2. CRANK DISK (RECORD SENSING PIN) | 10. FWD (◀◀), BWD (▶▶) BUTTONS
W/IPLS FUNCTION |
| 3. SPEED 33/AUTO/45 SELECTOR | 11. POWER ON/OFF SWITCH |
| 4. SENSOR SENSITIVITY LOW/MID/HIGH SELECTOR | 12. PROGRAM DISPLAY |
| 5. STYLUS CHANGE PLATE | 13. INTRO SCAN INDICATOR |
| 6. DOOR (CABINET) OPEN/CLOSE BUTTON | 14. SPEED 33/45 INDICATORS |
| 7. START (◀)/CUT (▶) BUTTON | |
| 8. RANDOM PROGRAM PLAY SYSTEM BUTTONS
INTRO SCAN, PROGRAM, CLEAR,
1~7 (PROGRAM) | |

IV. PRINCIPAL PARTS LOCATION

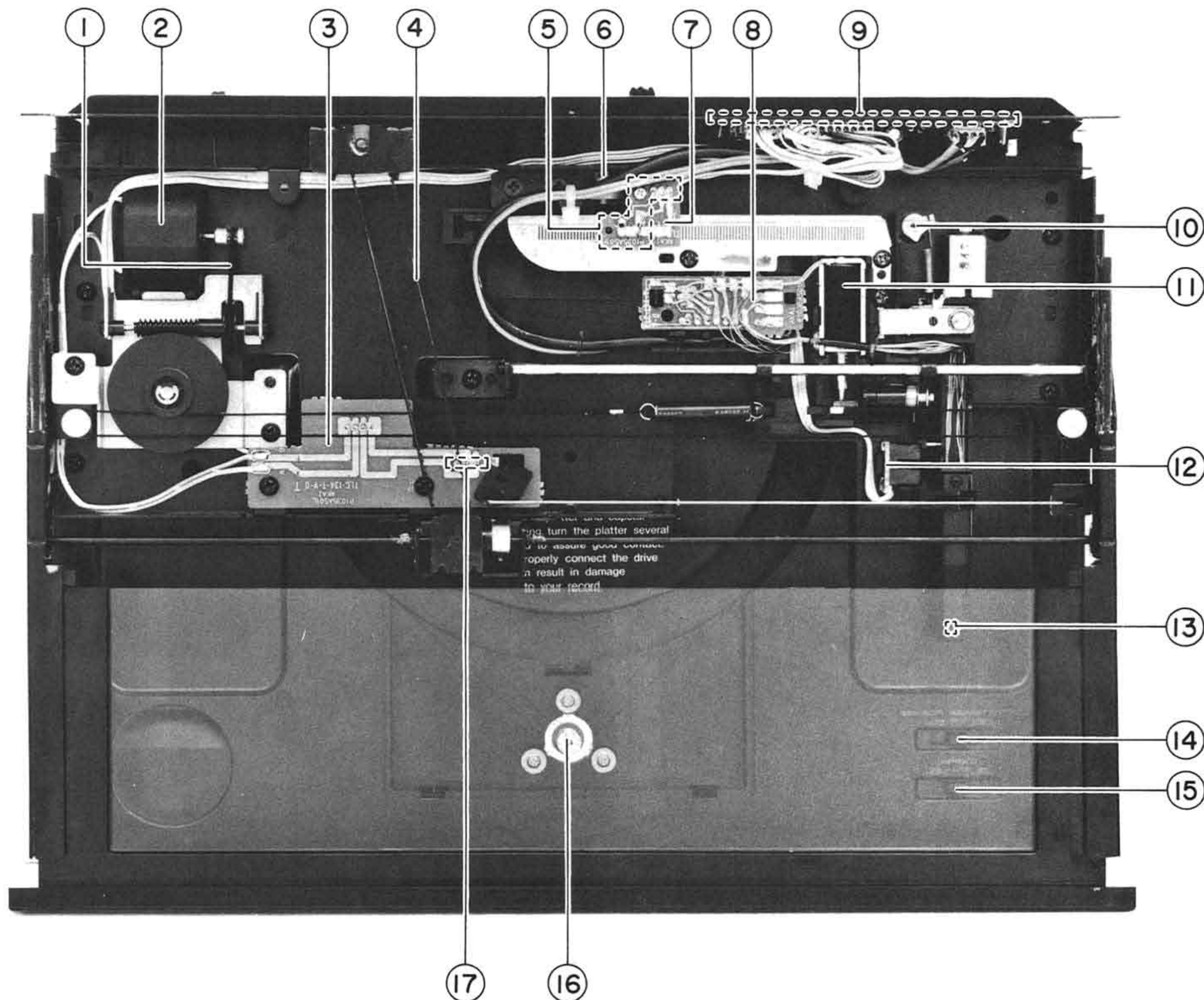

Fig. 4-1 Top View

- | | |
|---|--|
| 1. BELT (1.2 x D26) | 11. PLUNGER SOLENOID (SL901) |
| 2. ARM MOTOR MMN-5C2RG (M901) | 12. TRACKING PCB P1035A501P |
| 3. REST PCB P1035A501L | 13. PHOTO SENSOR (PH1)
FOR MUSIC INTERVAL DETECTION |
| 4. SYNCHRO BELT | 14. SENSOR SENSITIVITY LOW/MID/HIGH
SELECTOR (SW1) |
| 5. POSITION SENSOR (LED) PCB P1035A501G | 15. SPEED 45/AUTO/33 SELECTOR (SW2) |
| 6. LEAD-IN POSITION ADJUSTER | 16. MAIN MOTOR BLOCK MMI-5P2R (M903) |
| 7. POSITION SENSOR (PTR) PCB P1035A501H | 17. REST POSITION SW (SW1) |
| 8. RELAY PCB P1035A501F | |
| 9. AUDIO PCB P1035A501B | |
| 10. STYLUS PRESSURE FINE-ADJUSTER | |

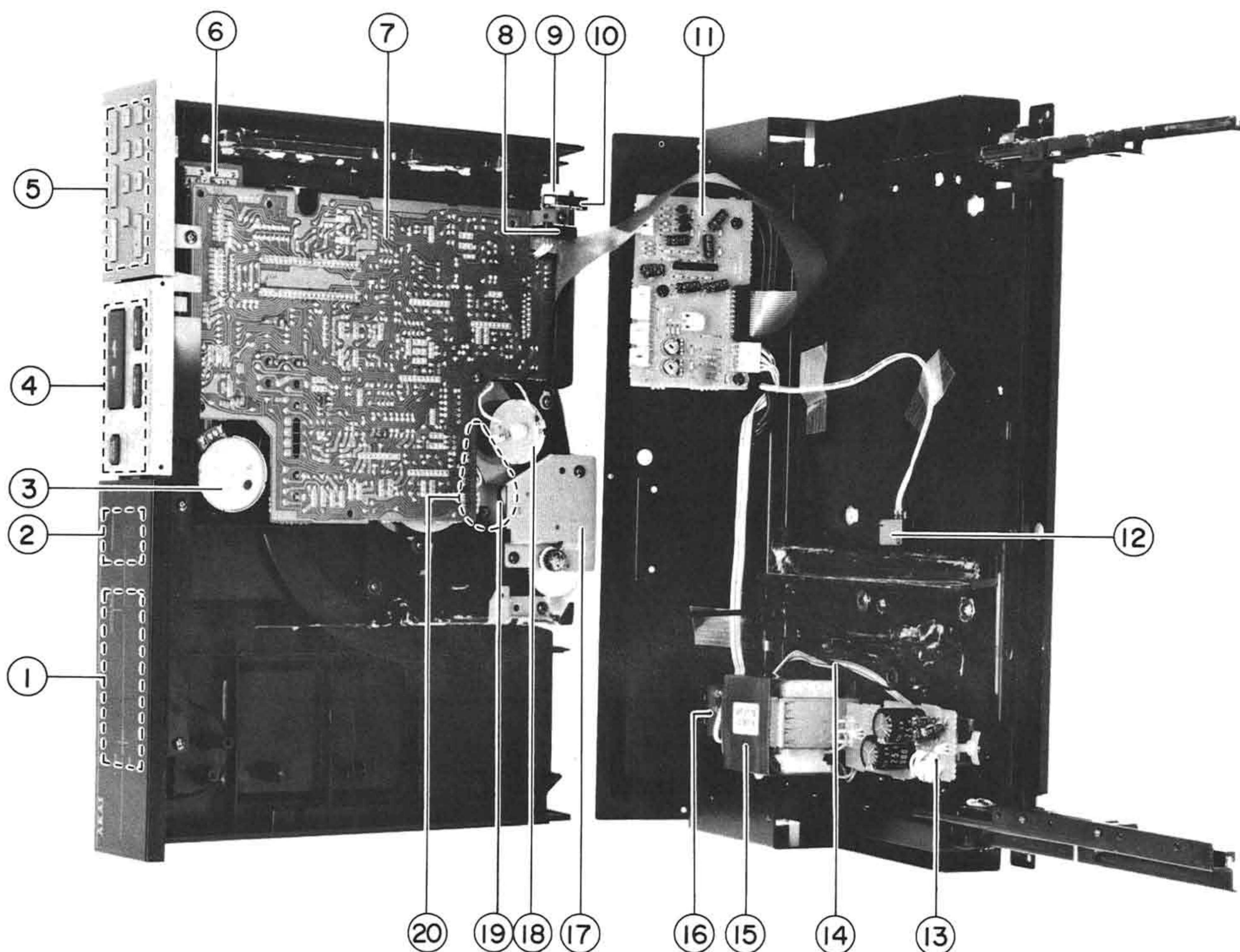

Fig. 4-2 Inside View

- | | |
|--|---|
| <ol style="list-style-type: none"> 1. IND PCB P1035A501M 2. PROGRAM IND PCB P1035A501K 3. MAIN MOTOR BLK (M903) MMI-5P2R 4. KEY BOARD (B) PCB P1035A501E 5. KEY BOARD (A) PCB P1035A501D 6. SLIDE PCB P1035A501N 7. SYSTEM CONTROL PCB P1035A501A 8. CLOSE SW (SW2) 9. LIMIT PCB P1035A501J 10. OPEN SW (SW1) 11. AUDIO PCB P1035A501B 12. PLAY POSITION SW (SW902) 13. POWER SUPPLY PCB P1035A501C 14. SYNCHRO BELT | <ol style="list-style-type: none"> 15. POWER TRANS (T901)
 APT-77-10 (<input type="checkbox"/> J MODEL)
 APT-77-20 (<input type="checkbox"/> A MODEL)
 APT-77-30 (<input type="checkbox"/> C MODEL)
 APT-77-40 (<input type="checkbox"/> E MODEL)
 APT-77-50 (<input type="checkbox"/> B <input type="checkbox"/> S MODELS)
 APT-77-70 (<input type="checkbox"/> U MODEL) 16. VOLTAGE SELECTOR (SW901)
 <input type="checkbox"/> U MODEL ONLY 17. GEAR BLOCK 18. SLIDE MOTOR MMN-5C2R (M902) 19. WIND BELT 20. SLIDE MOTOR BELT |
|--|---|

V. DESCRIPTION OF MISCELLANEOUS OPERATIONS

5-1 OUTLINE OF AP-M77 FUNCTIONS

- 1) Electronic Type Full-Auto Player
Judges a disc record to be one of the three sizes, 30 cm, 25 cm, and 17 cm (the size judgement may therefore be disabled on occasions), leads in accordance with the judged size, plays it, and upon concluding the play, will lead out, again in accordance with the size.
- 2) Direct Program Selection
Enables the programming of up to 7 pieces of music for playing, and the storage of up to a maximum of 15 pieces in the memory.
In selecting music pieces, rather than traversing the entire record surface for search every time or returning the arm to the arm rest each time a piece has been played and searching for the next piece, directly plays the target piece by traversing over the shortest distance.
- 3) Skip & Dock
During the play of a record, when the FWD key is pushed, will play either the spatially next piece or the next programmed piece, and when the BWD key is pushed, will play the current piece from its beginning over again.
- 4) Common Bus Operated Synchro-Play & Auto-Function
When copying on a cassette deck, will automatically perform such intelligent linkage plays as having the deck make 4 seconds of an unrecorded blank space, and just before the target music piece begins, and then only, having the deck phase out of the REC Pause and start recording.
As the player is started, the amplifier function will automatically be switched to Phono, while when conversely, other components operate and the function is varied, will automatically cut the play off.
- 5) Mode Confirmation by Attention Display
In the case of an anomalous or erroneous operation, or a particularly important behavior, will draw the user's attention to it with a 7-segment LED display.
- 6) Fail-Safe
When an object operation fails to be performed for long, or when this player has been started without any record on the turntable, will automatically disengage the mode.
- 7) Intro-Scan
After playing 8.4 seconds of a piece from the beginning, will play 8.4 seconds of the beginning of either the next piece or the next programmed piece, and keep repeating this cycle.

- 8) Program Auto-Homing
When in a program mode, the FWD/BWD key is pushed, the arm will traverse across and above the record, and then when the key is released with the arm midway above the record, will automatically lead in to the beginning of a piece above which the key has been released.

5-2 SPECIFICATION OF VARIOUS KEY OPERATIONS

5-2-1 Start/Cut

- 1) When at Open Position
 - Will output "DISK" to the common bus, have the main motor switched on, and 0.3 seconds later, will have the door closed. By means of a record sensing switch, when no record has been loaded, will display "E" and have the door opened. When a record has been loaded, will have the door held at the play position, and while detecting the record size, will lead in to the target music piece.
- 2) When at Play Position
 - When the arm is at the rest position, but no start mode has been engaged, will output "DISK" to the common bus, have the main motor switched on, and 2 seconds later, have the arm forwarded. When the record size has not been detected yet, will lead in to the target piece of music while detecting the size. When the size detection is disabled, will display "E" and cut the play off. Thereafter, even when the key is pushed again, will only display "E" and refuse to acknowledge the input. While the record size is being detected, a 7-segment LED will display "0" through "7" sequentially, thereby indicating the size detection in process.
 - When the arm is at other than its rest position, or even at the rest position, will cut the play off if a start mode has been engaged. If an intro-scan or program mode has been engaged, will disengage the mode, turn the "intro" LED off, and have the 7-segment LED display "-". If an arm-down operation is in process, will have an arm-up operation performed and then have the arm returned to the rest position.
- 3) When at Closed Position
 - Will display "E." and acknowledge no command inputs.
- 4) When at Any Other Position than 1), 2), and 3)
 - Will cut the play off if in a start mode. When in any other mode, will only display "E."

5-2-2 Open/Close

- 1) When at Open Position
 - Will have the main motor switched on, and 0.3 seconds later, have the door closed. By means of the record sensing switch, will engage a stop mode at the closed position if no record has been loaded, or at the play position if a record has been loaded.
- 2) When at Play Position
 - Will have the play cut off, and after the arm returns to the rest position, have the door opened. Will also clear the record size and inter-piece data.
- 3) When at Closed Position
 - Will have the play cut off, and then have the door opened.
- 4) When at Any Other Position that 1), 2), and 3)
 - Will have the door opened at any other position. It is only when at the door open position that closing operations will be performed, and at all other times, when the key is pushed at the door closed position to have an opening operation performed, will have it opened, but when at the door open position, will not have it closed.
 - Upon receiving the key input, an 8.4-second timer will be activated, and if the designated position is not reached within the time duration, "E." will be displayed and the slide motor stopped. In addition, a similar timer will also be activated for opening/closing operations during a start mode. When the key is pushed for a second time, opening operations will be phased into.

5-2-3 Power

- 1) This is a power-on/off switch that cyclically operates to switch power on when it has been off, or off when it has been on. This key will be acknowledged regardless of a multiple push or a follow-on push, and in any mode.
- 2) At 2 seconds after power-on, will return the arm to its rest position, and in the interim, will acknowledge no other key than power. When the arm has been at its rest position from the beginning, will acknowledge no other key for 2 seconds.
- 3) When at power-on, the door is at a position other than prescribed, will have it opened after the arm has returned to its rest position.

5-2-4 Intro-Scan

- 1) Unless the mode is intro-scan and the size detection has been disabled, will have the "intro" LED glow, and have the music introduction played for 8.4 seconds. Unless in a program mode, will store

[Current Music-Piece Number + 1] in the "intro" memory. Only, if it is the 15th piece, no such storage will be made.

- 2) When in an intro-scan mode, will turn the LED off and disengage the intro-scan mode.

5-2-5 Forward

- Will acknowledge this key at the play position only.

1) Prior to Size Detection

- When this key is pushed, the arm will forward. As soon as it leaves its rest position, the main motor will be switched on, and "0" through "7" displayed.
- As the arm reaches the 30 cm disc lead-in position, the decimal point of the 7-segment LED will flash on and off, and the arm will stop.
- When the key is released and pushed again, the arm will forward again and the decimal point stop flashing, until the 25 cm disc lead-in position is reached where the arm will again stop. Then, when the key is pushed one more time, the arm will stop at the 17 cm disc lead-in position.
- When the key is pushed still further and the arm reaches the 17 cm disc lead-out position, the arm will stop, and an "E." display and a disabled record size judgement will be effected together.

2) During Down Operations

- Will have an arm-up operation performed and if in a full-auto mode, will skip to [Current Music-Piece Number + 1]. Only, if the current piece is the 15th, will only have the arm-up operation performed.
- When in a program mode, programmed pieces still remain stored in the memory, will skip to the next programmed piece. When they are not stored, only the arm will be lifted up.

3) During Up Operations

- If in a full-auto mode, will forward, even in an intro-scan mode, as long as this key is held down. Will, however, stop at the innermost circumference dictated by the record size. When the key is released, the arm will stop immediately.
- In a program mode, will forward similarly to the full-auto mode as long as the key is held down, but when it is released, will lead in to the beginning of the then current piece of music. Since when the piece is ended, the original program play will be resumed, any music piece may be inserted at will. However, only the beginnings of music pieces having numbers 1 through 15 will be treated this way.

5-2-6 Backward

- Will acknowledge this key only at the play position.

1) During Down Operations

Will have an arm-up operation performed, and lead in to the beginning of the current music piece.

2) During Up Operations

- If in a full-auto mode, will have the arm move backward even in an intro-scan mode, as long as this key is held down. However, upon return to the rest position, the arm will stop, and the intro-scan mode and program mode disengaged. When the key is released, the arm will stop immediately.

- In a program mode, while the key is held down, will shift the arm backward in the same manner as in a full-auto mode, but when the key is released, will lead in to the beginning of the then current piece of music.

Since when the piece is concluded, the original program play will be resumed, any of the pieces of music may be inserted at will. However, only the beginning of music pieces having numbers 1 through 15 will be treated this way.

5-2-7 Cue

- Will acknowledge this key at the play position only.

1) Prior to Size Detection

- Will acknowledge this key and have an arm-down operation performed, only when the arm has been forwarded with the forward key and stopped at one of the various lead-in positions. As a result, the record size having the lead-in position will necessarily be confined to.
- When at a point where the decimal point does not flash on and off, will display "E."

2) Subsequent to Size Detection

- Will acknowledge this key only within the record playing range (from the lead-in position to the lead-out position) that corresponds to individual record sizes. Will, however, not acknowledge the key when the arm is in motion, during arm-up operations, in down servo modes, and in lead-in awaiting modes.
- During an arm-down operation, will have the arm lifted up, and during an arm-up operation, will have it lowered down. In a full-auto mode but not in intro-scan mode, will refuse to acknowledge this key for 2 seconds after the plunger has been switched off and the arm lifted up. In any other mode, will refuse to acknowledge it for 4 seconds.
- In a manual arm-down operation under the cue key, will output "DISK" to the common bus, and will disengage the muting mode and output

"Pause-Cancel" to the common bus immediately when stylus signals are present, or 3 seconds later when they are not.

- In an arm-up operation, will exercise muting immediately, and 0.3 seconds later, will have the plunger switched off, as well as have the tracking sensor also switched off another 0.3 seconds thereafter. When lifting the arm up during a down operation, however, will immediately have the plunger and tracking sensor switched off. In either case, will not regard the arm to have been fully lifted until 2 seconds later, but will regard the up operation still to be in process. Another 2 seconds later, will output "Play-Cancel" to the common bus.

5-2-8 Program-Clear

- 1) Nothing will happen except in program modes.
- 2) In a program mode, will cancel the program, display "-", disengage the program mode, and phase into a full-auto mode. When during a start mode, will lead in, or when searching for a music piece, will cut the play off.

5-2-9 Program-Check

- 1) When in a program mode, programmed music-piece numbers have been stored, will have the 7-segment LED turned off for 0.3 seconds, and then have it display each of the programmed piece numbers in the stored sequence for 1 second followed by 0.3 seconds of a display-off period. In this process, will not display numbers of the music pieces whose program has been executed, but will make the display starting with the number of the music piece to be played next.
- 2) When this key is pushed during a program checking process, will cancel the program check mode and suspend any further display.

5-2-10 Program

- 1) Will acknowledge this key unless the record size judgement has been disabled.
- 2) When keys 1 through 7 are pushed, will have the depressed key number displayed for 1 second, and engage a program mode. In this process, the decimal point in the 7-segment LED will also be made to glow, and to keep on glowing until the program mode is disengaged, unlike the 7 segments.
- 3) Numbers of up to 15 pieces of music may be stored in the memory, and the music will be played in the sequence of number inputs. When the input of 16 or more numbers is attempted, will display "F." and indicate no further programming capabilities.
- 4) As a programmed music piece is played, will clear its number, creating room for one more number, so that up to 15 pieces may be stored at all times.

5-3 SPECIFICATION OF VARIOUS LEDS

5-3-1 "Intro" LED

- 1) Will glow when the intro-scan key is pushed and an intro-scan mode engaged.
- 2) Will go out when in an intro-scan mode, this key has been pushed and the mode manually disengaged, or when a play cut-off operation has disengaged the mode.

5-3-2 7-Segment LED

- 1) Program Key Input Mode
 - Will display the pushed music piece number for one second. When during a display, a program key is pushed, will display the newly pushed piece number for one second.
- 2) Attention Mode
 - Will display "E.", "-", or "F." which signify Error, Clear, or Full respectively.
 - The display will be flashing at intervals of 0.26 seconds, and go on flashing for 2 seconds.
- 3) Program Check Mode
 - After 0.3 seconds of no display, will display a music-piece number for one second, and then another 0.3 seconds of no display will follow. When a balance will remains of the program, will also display the remainder similarly.
- 4) Size Detection Mode
 - Will display "0." through "7." in program modes, or "0" through "7" in all other modes, sequentially for 0.26 seconds each, and cyclically, returning to "0" after "7", until the size detection is concluded.
- 5) When at Armrest Position
 - Will display "0." in program modes, or "0" in all other modes.
- 6) Mute-On Mode
 - Will flashingly display for 0.52 seconds the number of the piece of music that is beneath the stylus on the record.
- 7) Mute-Off Mode
 - Will steadily display the number of the piece of music that is beneath the stylus on the record.

5-4 SPECIFICATION OF COMMON BUS

5-4-1 Inputs

- 1) DISK-START
 - Prior to the size detection, the arm is at its rest position, while this input will be acknowledged only at the open position or the play position of the cabinet. Thereafter, similarly to normal start operations, will detect the size and lead in.

- Subsequent to the size detection, will not acknowledge this input when the detection has been disabled, but will do so only when the arm has just been lifted up, and lead in to the first music piece in a full-auto mode, or to the target piece in a program mode.

2) PHONO-REC

- The same as DISK-START.

3) TUNER & TUNER-REC

- The arm is at its rest position, and will acknowledge this input only during a start operation. Will have cut-off operations performed in all other cases. Will not output "REC-CANCEL" into the common bus.

4) DAD & DAD-REC

- The same as TUNER.

5) DECK

- The same as TUNER.

6) AUX

- The same as TUNER.

7) Other Codes

- Will refuse to acknowledge any other code.

8) Power-Off Mode

- Will acknowledge codes 1) to 7) just for the first time, and after switching power on, perform the operation corresponding to the code.

5-4-2 Outputs

1) DISK

- Will be output when the START/CUT key has been pushed and a start mode manually engaged.
- Will be output when the arm lowers down.

2) PAUSE-CANCEL

- Will be output when muting is disengaged.

3) PLAY-CANCEL

- Will be output 4 seconds after muting has been turned on when the arm is lifted up by other than a cut-off operation. However, when the arm fails to return to the armrest or the play has been cut off other than through the common bus, "STOP" will be output, rather than "PLAY-CANCEL", as 4 seconds have elapsed.

4) STOP

- Will be output 4 seconds after muting is turned on, when the arm has been lifted up by a cut-off operation and other than through the common bus. However, when the arm fails to be at the rest position or the cut-off operation is no longer in process, "PLAY-CANCEL" will be output, rather than "STOP".

5-5 TIMING OF VARIOUS OPERATIONS

5-5-1 Lead-In

- 1) The arm will stop as it reaches a lead-in position. If this is within 4 synchro seconds, will wait till the 4 seconds elapse, and then output "PLAY-CANCEL". If it is outside the 4 synchro seconds, will not output "PLAY-CANCEL".
- 2) Will output "DISK" 0.6 seconds later, and have the plunger switched on and the arm lowered down.
- 3) For 0.3 seconds after the plunger has been

- switched on, will disregard stylus noises, and if during the ensuing 0.7 seconds, stylus noises emerge, will have the tracking sensor switched on.
- 4) If no stylus noises emerge during the 0.7 seconds, will have the tracking sensor switched on, one second thereafter.
- 5) At the end of 0.3 seconds after the tracking sensor has been switched on, will output "PAUSE-CANCEL", and disengage muting.

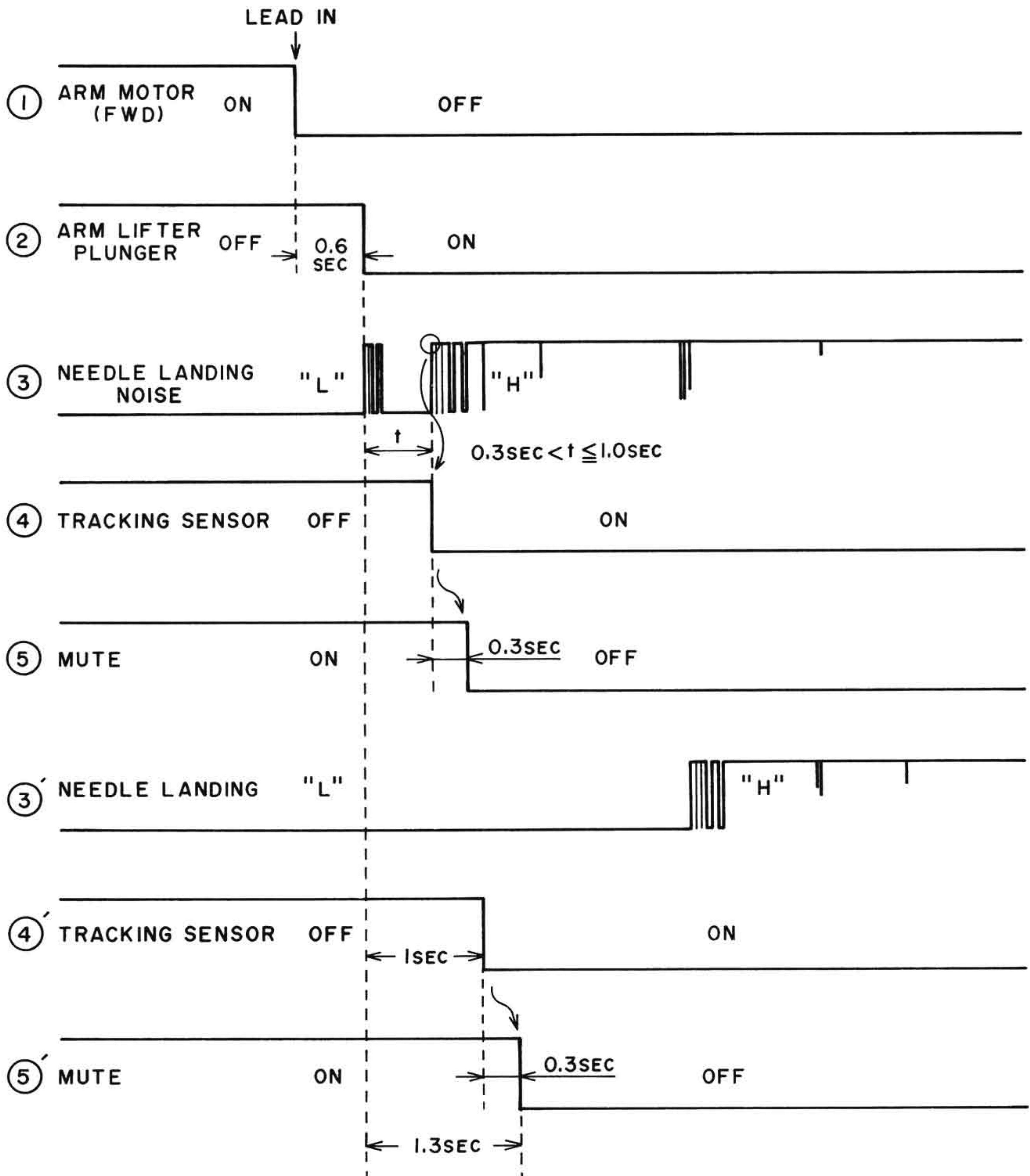

Fig. 5-1

5-5-2 Music-Piece Interval Search Down

- 1) As the target music-piece interval is reached, the arm will stop. If it is within 4 synchro seconds, will have down servo exercised, and as the 4 seconds have elapsed, will output "PLAY-CANCEL". If it is outside the 4 synchro seconds, will not output "PLAY-CANCEL".
- 2) Will then exercise another second of down servo, and output "DISK", having the plunger switched on and the arm lowered down. Thereafter, will disengage the down servo.
- 3) For 0.3 seconds after the plunger has been switched on, will disregard stylus noises, and if

- during the ensuing 0.7 seconds, stylus noises emerge, will have the tracking sensor switched on.
- 4) If no stylus noises emerge during the 0.7 seconds, will have the tracking sensor switched on, one second thereafter.
- 5) For 0.3 seconds after the tracking sensor has been switched on, will disregard audio signals. If audio signals are at "L" at the end of the 0.3 seconds, will output "PAUSE-CANCEL" and disengage the muting mode. If audio signals are at "H", will continue exercising muting until they drop down to "L".

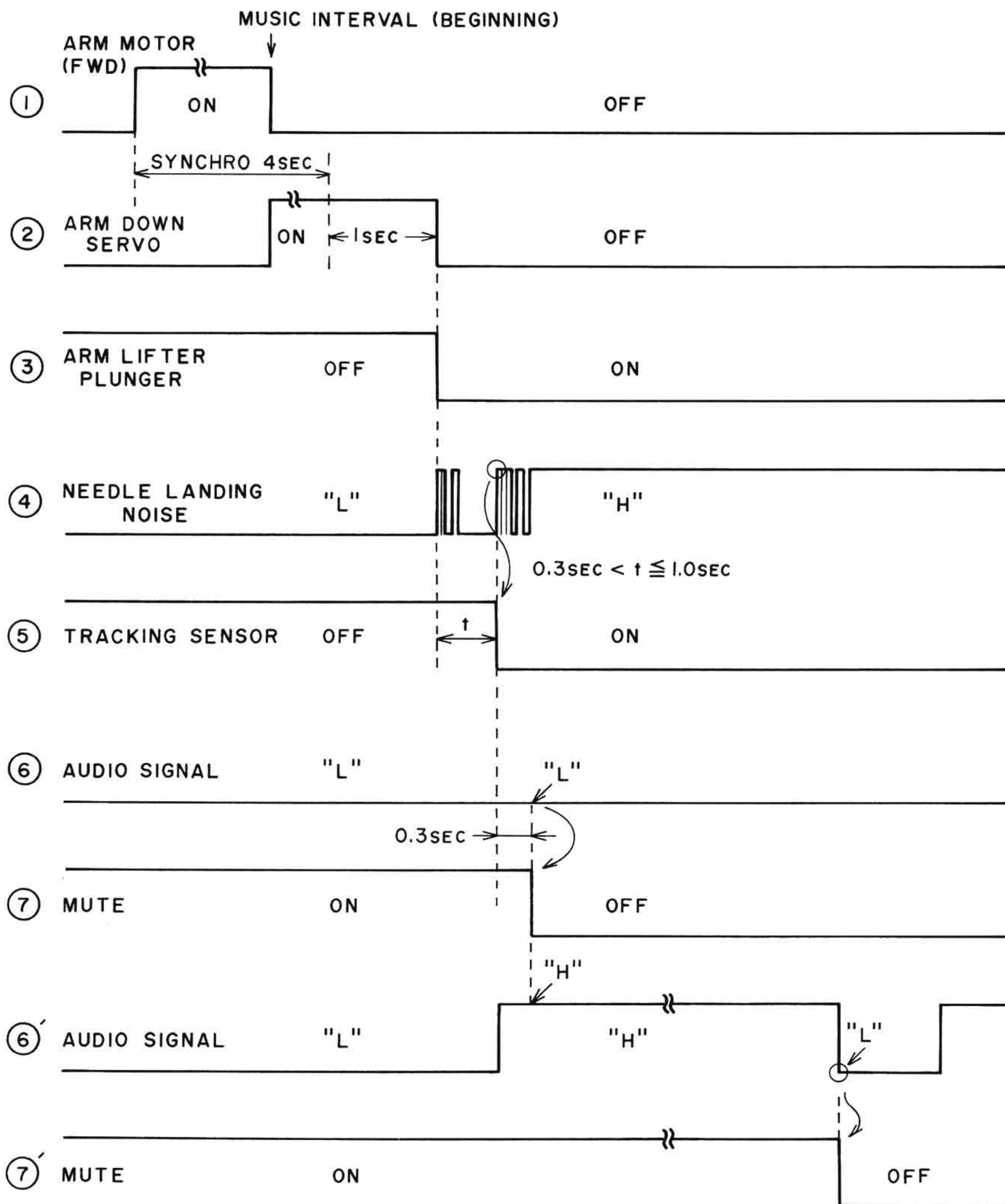

Fig. 5-2

5-5-3 Manual Arm-Down

- 1) When arm-down operations are possible, will output "DISK", and have the plunger switched on and the arm lowered.
- 2) For 0.3 seconds after the plunger has been switched on, will disregard stylus noises, and when during the ensuing 0.7 seconds, stylus noises emerge, will have the tracking sensor switched on

- and the muting mode disengaged.
- 3) When no stylus noises emerge during the 0.7 seconds, will have the tracking sensor switched on one second later, and the muting mode disengaged.
- 4) When disengaging the muting mode, will output "PAUSE-CANCEL".

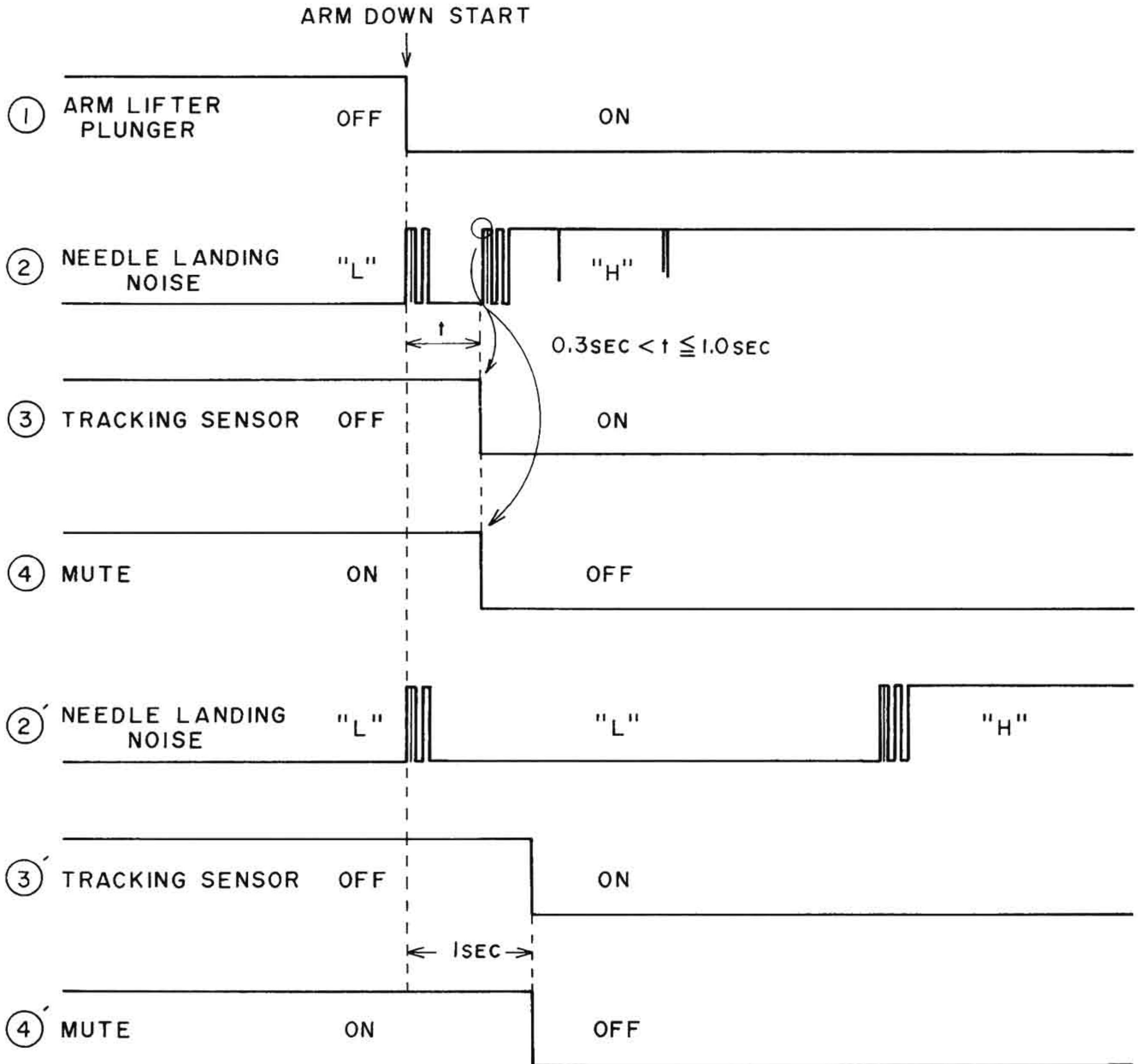

Fig. 5-3

5-5-4 Arm-Up

- 1) Will exercise muting.
- 2) Will have the plunger switched off 0.3 seconds later, and the arm lifted up.
- 3) After another 0.3 seconds, will have the tracking sensor switched off.
- 4) When 2 seconds have elapsed since the muting start, will judge the arm lifting to have been

concluded, and permit the arm to be shifted as required.

- 5) When an output to the common bus is required, will provide the necessary output 4 seconds after the muting start (either "PLAY-CANCEL" or "STOP").

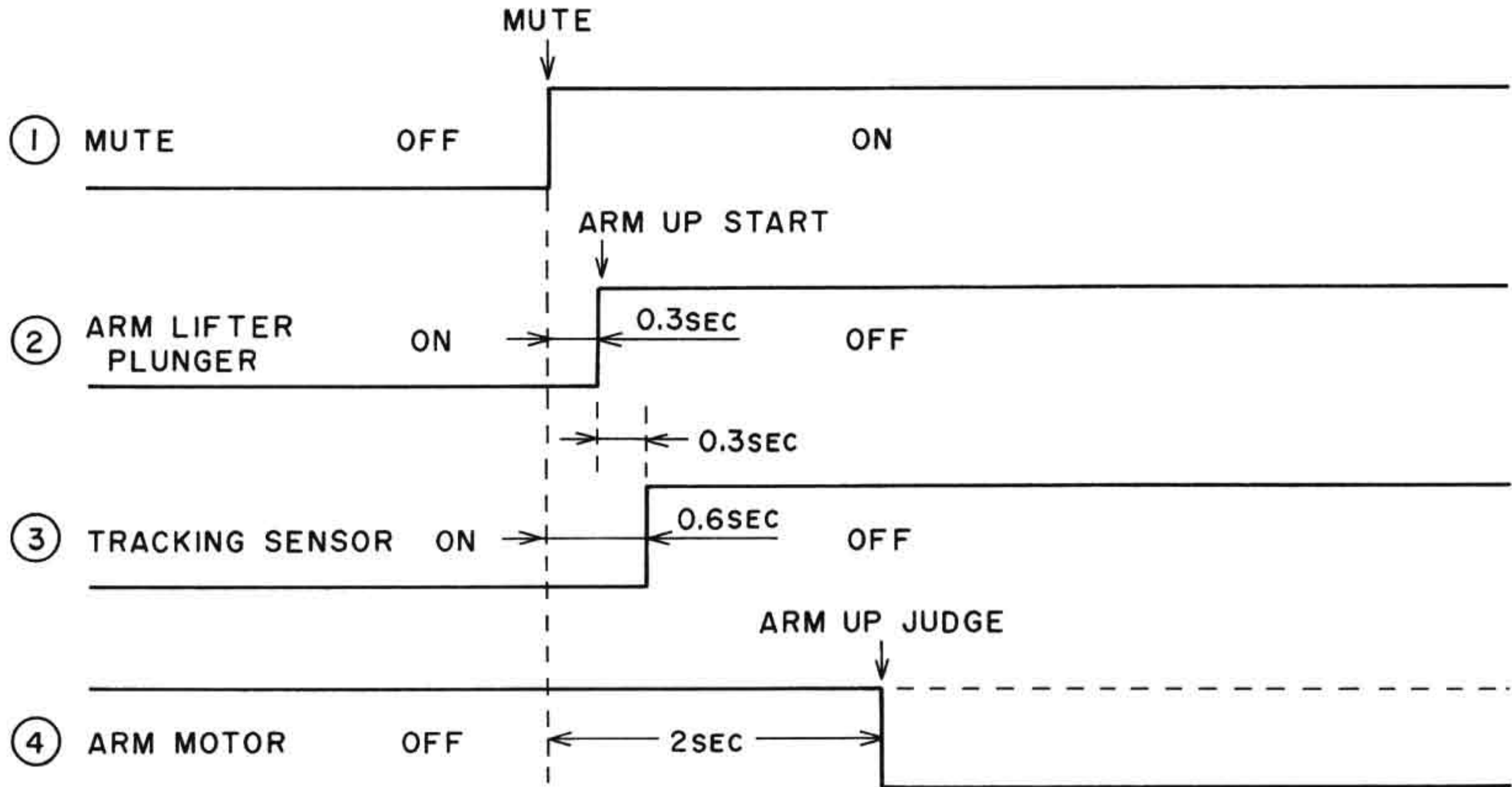

Fig. 5-4

5-5-5 Music-Piece Interval Detection in Play Mode

- 1) When the arm has been fully lowered, will detect 1.2 seconds minimum of a continuous "L" inter-piece signal.
- 2) When "L" is sustained for 1.2 seconds, will detect audio signals, and when they become "L" at a point removed by 2.5 mm (or 5 mm if the current

piece of music is the first piece) or more from the beginning of the current piece of music, will regard it to be a music-piece interval.

- 3) If the point is not removed sufficiently from the beginning of the music piece, will revert to detecting a 1.2-second continuous "L" inter-piece signal.

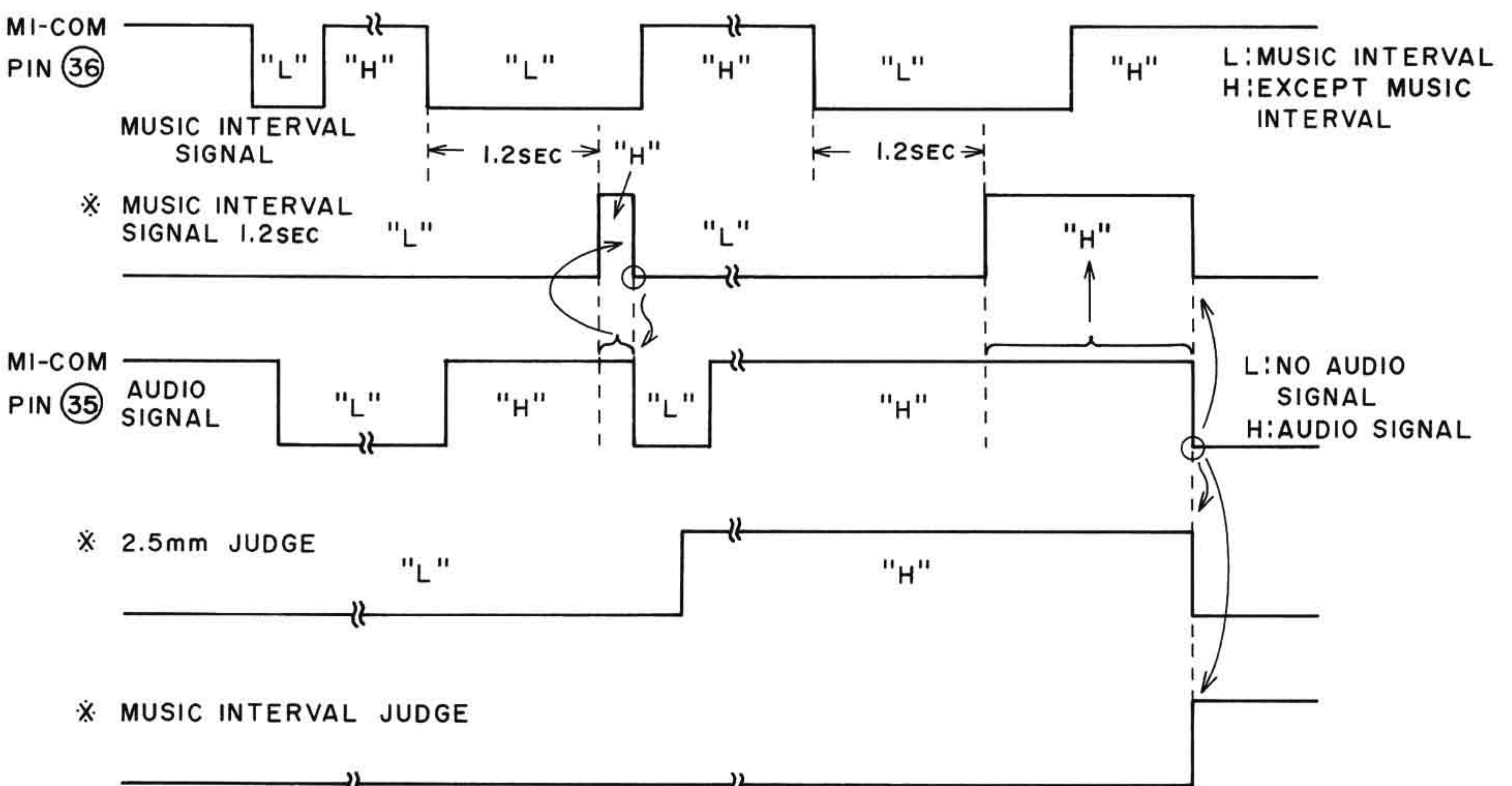

Fig. 5-5

5-5-6 Common Bus

- 1) When outputting, if the bus is busy, will not output. If it is not busy, will output a leader section.
- 2) If after outputting the leader section, the bus is again busy, it will mean a transmission from higher level equipment, so that a signal receiving mode will be engaged. If it is not busy, will output 8-bit data after outputting a check section first.
- 3) For 100 msec after a data output, will inhibit any further transmission.
- 4) In the case of reception, if the next data fails to arrive within a predesignated length of time, will regard the reception to be ineffective. When data to the last bit has been received, will refuse to be engaged in further reception until the received data has been decoded.

5-5-7 Common Bus System (Refer to Fig. 5-6)

For the network control of direct functions and synchro-recording functions among the tuner, pre-main amp, player, tape deck, CD player, and other individual pieces of equipment, a common bus system operated through serial data transfers has been employed.

The individual components will be joined to a common bus line with connectors in a two-wire configuration of the signal and ground lines.

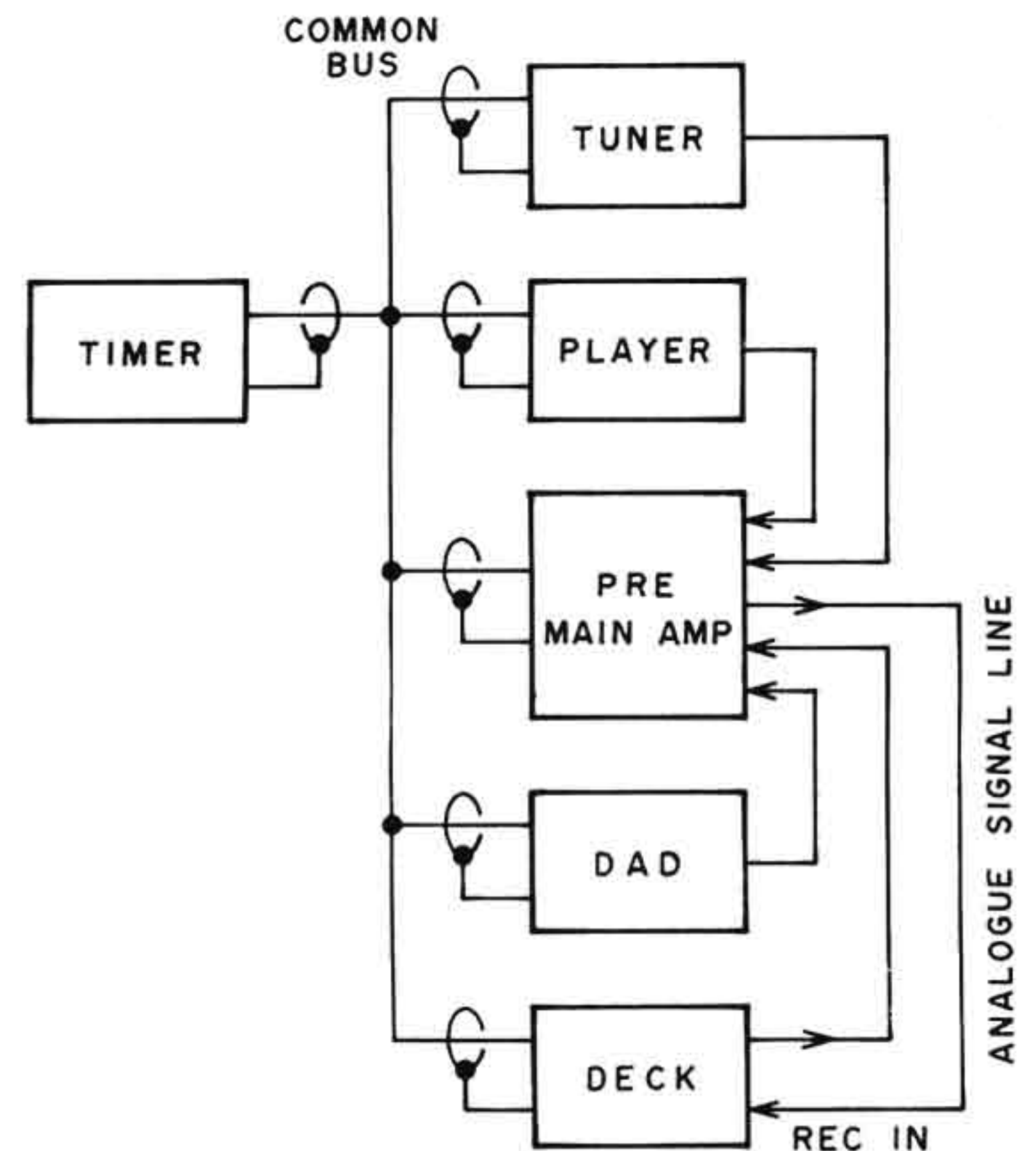

Fig. 5-6

1) Serial Data Code

As shown in Fig. 5-7, the serial data code is composed of the leader code, check code, and the data code.

Leader Code: Selects operating equipment.

Check Code: Provides the check time to prevent collisions of multiple simultaneous signals.

Data Code: Operational Contents.

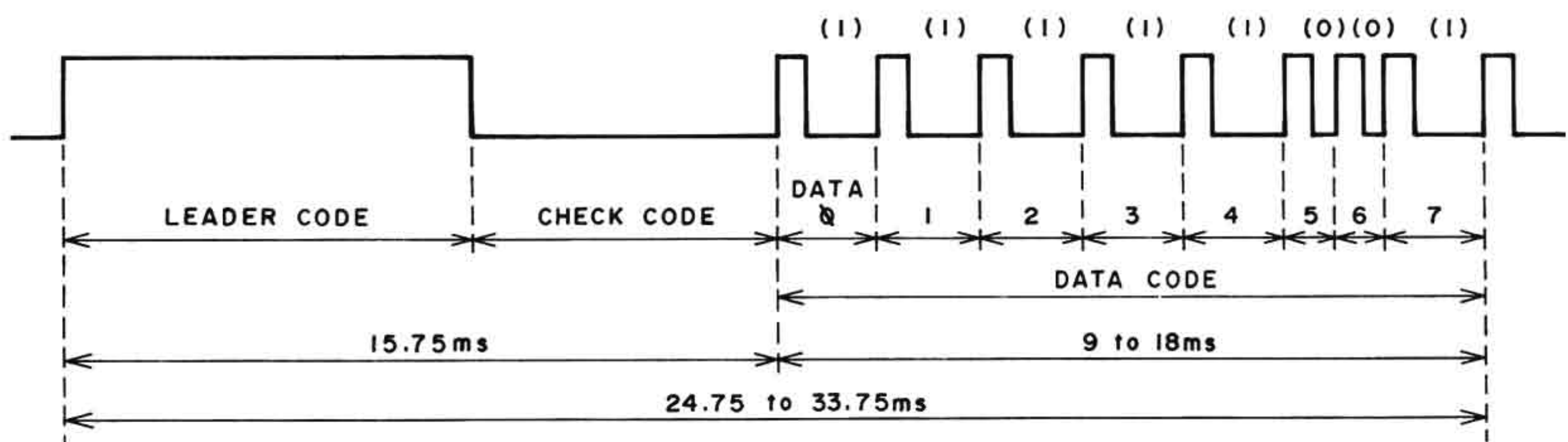

Fig. 5-7

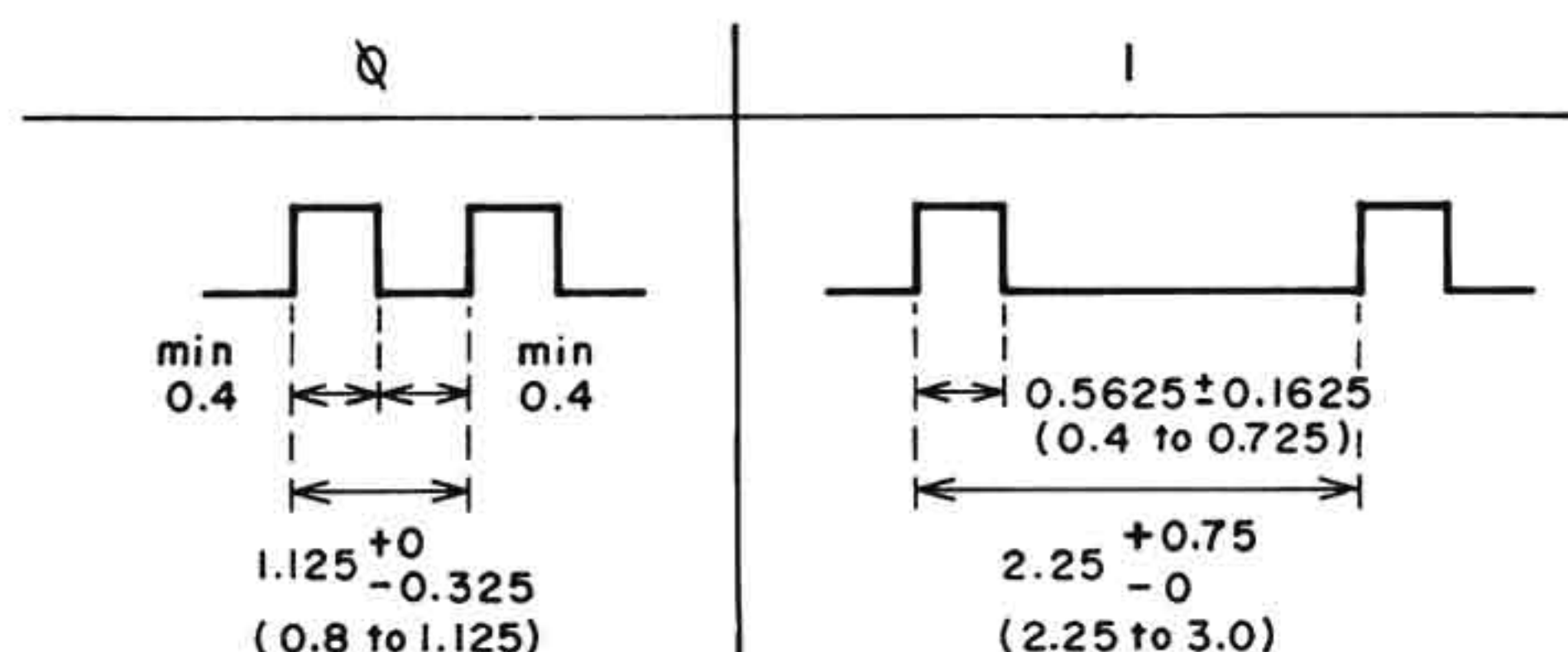

Fig. 5-8

2) Allocations for Individual Codes

a. Leader Code and Check Code

The individual equipment selecting leader code selects equipment based on the length of its code (Chart 1). With regard to the check code, because the total time for a leader code and a check code put together has been set at 15.75 ms, the remainder after deduction from 15.75 ms of the leader code will be used for the check code.

	Leader Code (ms)	Check Code (ms)
Timer	13.5	2.25
Player	12.375	3.375
DAD (CD)	11.25	4.5
Cassette Deck	9.0	6.75
Tuner	7.875	7.875
Pre-Main Amp.	6.75	9.0

All code lengths will be made $n \times 1.125$ ms.

Chart 1

The leader code with a wider pulse width always shall carry a higher priority than that with a narrower width.

b. Data Code

For the operational contents of individual equipment, their data shall be structured with combinations of 8 bits, so that 82 kinds of operational contents will be possible.

3) Data Transmission

a. Upon receiving a key input, the individual component shall check to assure the presence on the common bus (hereinafter, bus) of no data from other components before transmitting its data.

If any data is present there, not only shall the transmission be called off, but the key input shall also be made ineffective.

b. When no data is present on the bus, a prescribed leader code shall be output.

c. Upon concluding the output of a leader code, the bus shall be lowered to 'L', and the signal status on the bus checked again. If at that point, data is present on the bus, a higher priority component will have been outputting data, so that the transmission shall be called off.

NOTES: 1. In the case of a key input requiring data transmission, a key acknowledging mode shall be engaged only after confirming in advance the feasibility of sending the data.

2. An interval of 50 μ sec min. shall be provided after the lowering to 'L' before checking the bus (Fig. 5-9).

d. After the prescribed length of a check code, the 8-bit data code section shall be output.

e. An interval of 100 msec min. shall be provided after a burst of transmission before transmitting the next data.

4) Data Reception

a. The component specified by the pulse of a leader code section shall enter a receiving mode. Once the receiving mode is engaged, control signals through the bus shall take precedence, and key inputs shall be inhibited. Even when the receiving mode has been engaged immediately after a key acknowledgement, the key input shall be disregarded.

Even after a key input has been acknowledged and its processing already started, or when bus data arrives in the middle of a mechanism operation, bus data shall still be acknowledged. Only, processing of the bus data shall be executed after conclusion of such ongoing operations. Accordingly, the transmitting side shall not check for the verification as to whether the data has been received.

b. An interval of 100 msec min. shall be provided when transmitting data after receiving bus data.

c. When transmission and reception have overlapped, a receiving mode shall be engaged during the check code section of the transmission, and sustained thereafter.

d. The leader code length shall be so selected for the prevention of noise caused malfunctions that when no signal arrives for a prescribed length of time (20 to 40 msec), the receiving mode will be disengaged. A similar arrangement shall also be made for the reading of code sections.

5) When the Timings for Transmission and Reception Have Coincided with Each Other

When at the timing for an intended transmitting operation, data has been sent out on the bus by another component, the bus data shall be read, and 100 msec later, the intended data transmitted. However, when upon reading the data, the data transmission is found to be no longer required, the transmission shall be called off.

The 100 msec interval is required for these purposes, and when processing of the data read or equivalent requires more time than 100 msec, a longer than 100 msec interval may also be provided.

6) Collision Prevention on Common Bus Line

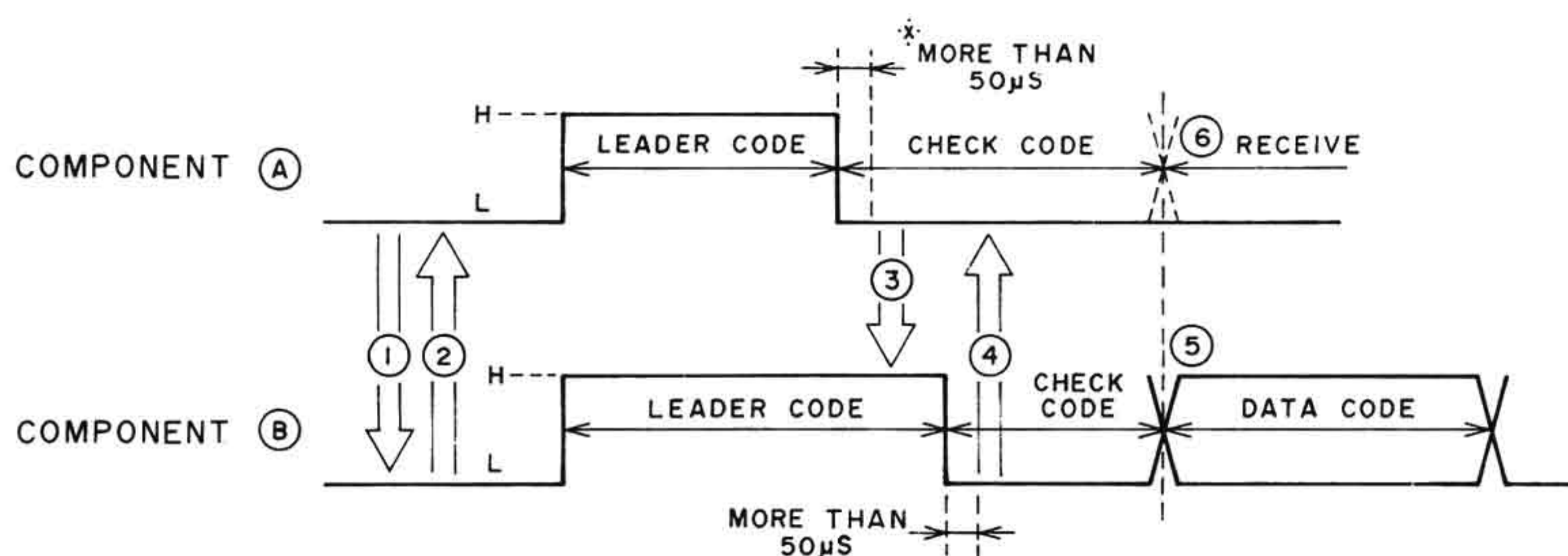

Fig. 5-9

- a. After checking for the presence of no data on the bus line, component (A) outputs a leader code.
 - b. Component (B) also outputs a leader code after checking for the presence of no data.
 - c. During the check code that follows output of the leader code, component (A) checks the bus line, and finding the component (B) data (leader code) there, will call off its transmission.
 - d. During the check code that follows output of leader code, component (B) checks the bus line for the presence of data on it.
 - e. Finding no data on the bus line, component (B) outputs a data code into the bus line.
 - f. Component (A) enters a receiving mode at the beginning of the data code.
- *1 When checking the bus line busy status after the output of a leader code, a 50 μ s min. interval shall be provided to avoid reading its own leader code that may be delayed in being output by a time lag within the devices employed.

VI. ADJUSTMENTS

6-1 ORDINARY MECHANICAL ADJUSTMENTS

- 1) Ordinary Mechanical Adjustments such as Stylus Pressure, Overhang and Tone Arm Height Adjustment are not necessary since this model is equipped with a Dynamic-Balance Linear Tracking Tone Arm.
- 2) Stylus Pressure is pre-adjusted to 1.25 grams at the factory, and re-adjustment is not necessary in normal conditions.
However, this model is equipped with the Stylus Pressure Fine-Adjuster located on Tone Arm Block.

Adjust it only when, for some reason, (Temperature, etc.) the stylus skips or there is distortion in the sound.

Stylus Pressure can be adjusted from the minimum 0.5 grams (Adjuster-fully counter-clockwise) to the maximum 2.0 grams (Adjuster-fully clockwise) centering around 1.25 grams. In other words, Stylus Pressure can be adjusted within 1.25 ± 0.75 grams by turning the adjuster clockwise or counterclockwise through an angle of about 45 degrees in each direction.

6-2 ELEVATION AND POSITION ADJUSTMENT (Refer to Fig. 6-1)

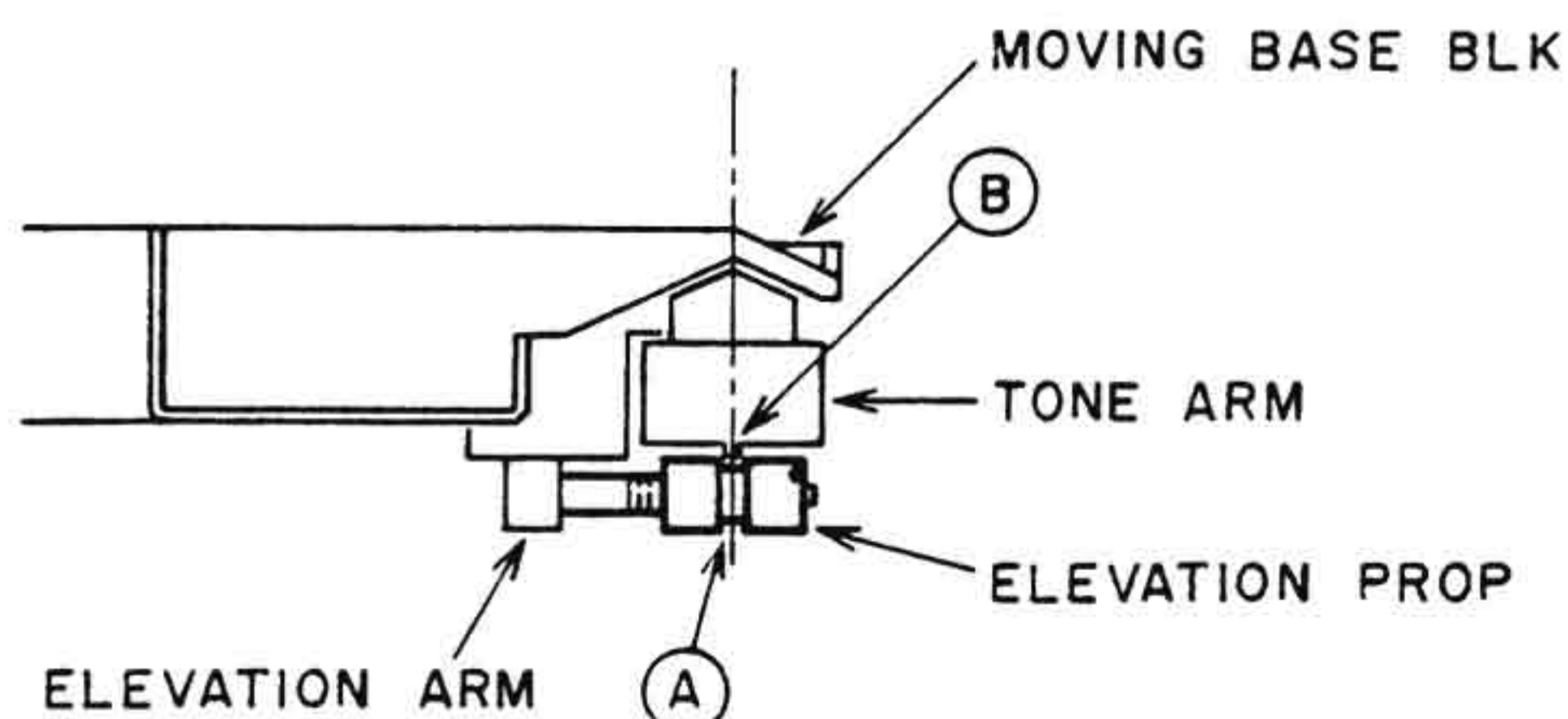

Fig. 6-1

- 1) This adjustment is not necessary unless the Elevation Arm or Elevation Prop is replaced or mis-adjusted.
- 2) Hold the Tone Arm with the Moving Base Block and separate the Elevation Prop from the Tone Arm.

Then, bring the Elevation Prop close to the Tone Arm, and adjust the Elevation Prop with a flat type screw-driver to the place where the position of the notch (A) on the Elevation Prop coincides with the projecting part (B) on the Tone Arm as shown in Fig. 6-1.

6-3 POSITION SENSOR SENSITIVITY ADJUSTMENT (Refer to Figs. 6-2, 6-3 & 6-4)

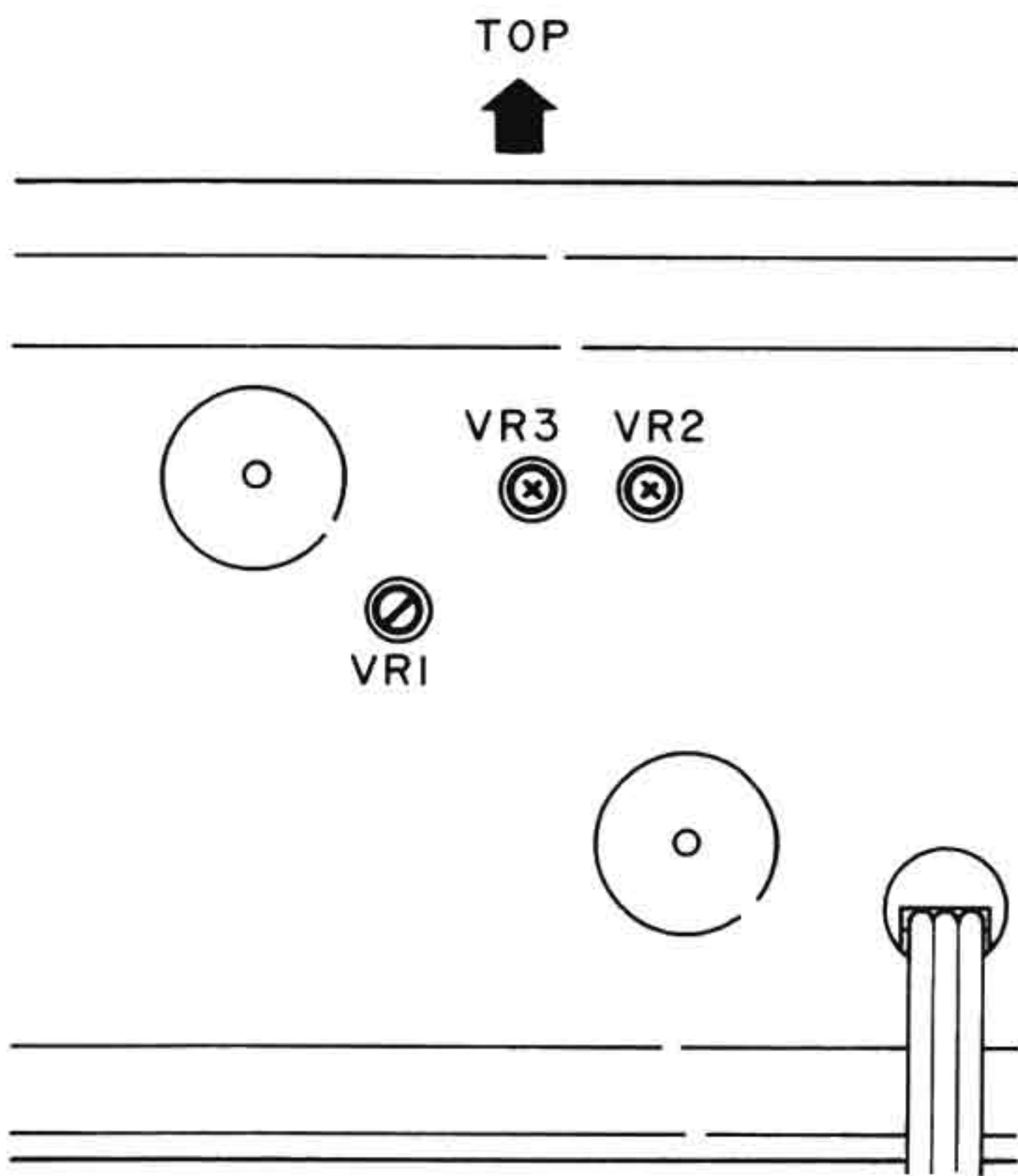

Fig. 6-2 Audio PCB ADJ Points (Rear View)

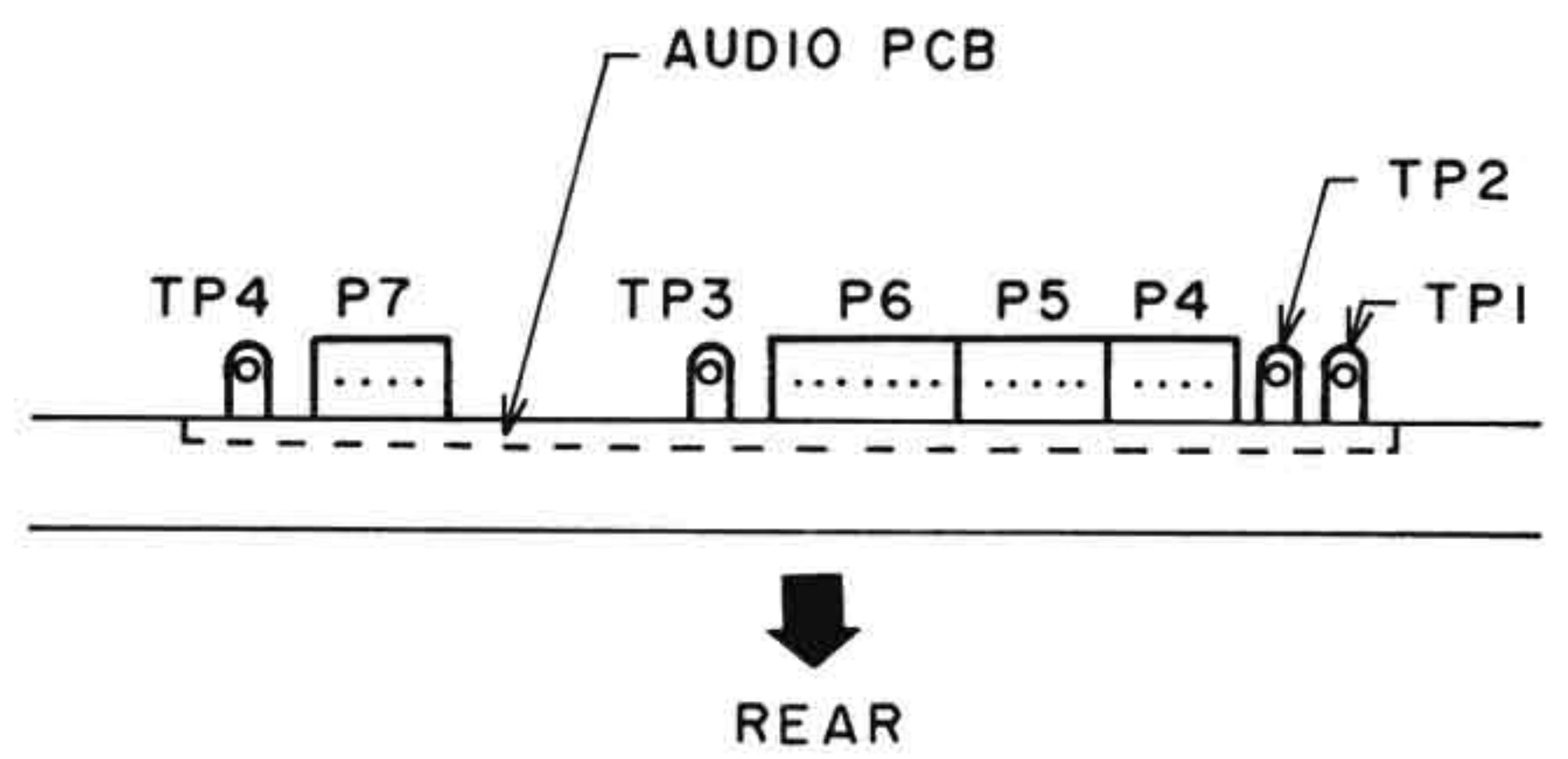

Fig. 6-3 Audio PCB Test Points (Top View)

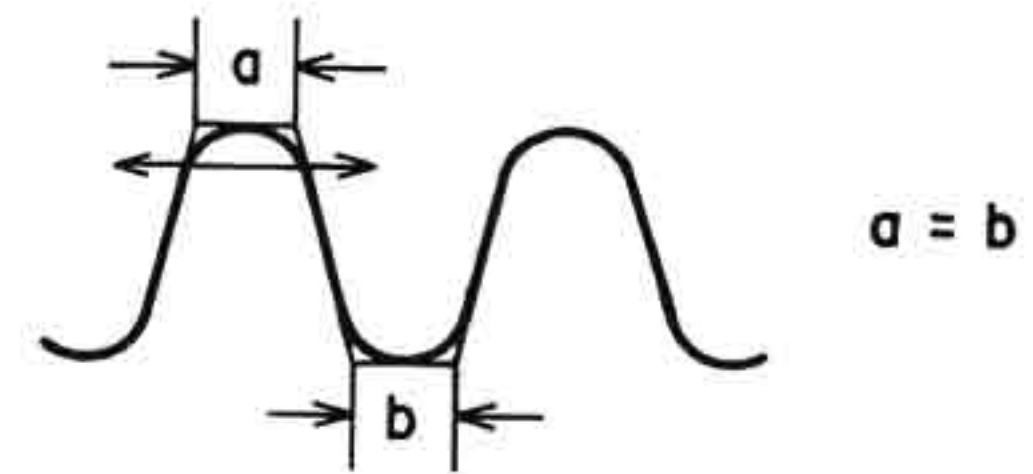

Fig. 6-4 TP1, 2 Waveform

- 1) This adjustment is not necessary in normal conditions unless the volumes VR2 or VR3 is replaced or misadjusted.
- 2) If this adjustment is necessary, turn on the power and place a 30 cm record on the platter.
- 3) Connect an oscilloscope between TP1 and TP4

- 4) Next, connect an oscilloscope to TP2 and adjust VR2 in the same manner as item 3).
- (GND) on AUDIO P.C BOARD, and observe the wave form while the Tone Arm is moving FWD or BWD above the record and adjust VR3 so that the duty of the waveform is 50% as shown in Fig. 6-4.

6-4 OFF-SET VOLTAGE ADJUSTMENT (Refer to Fig. 6-5)

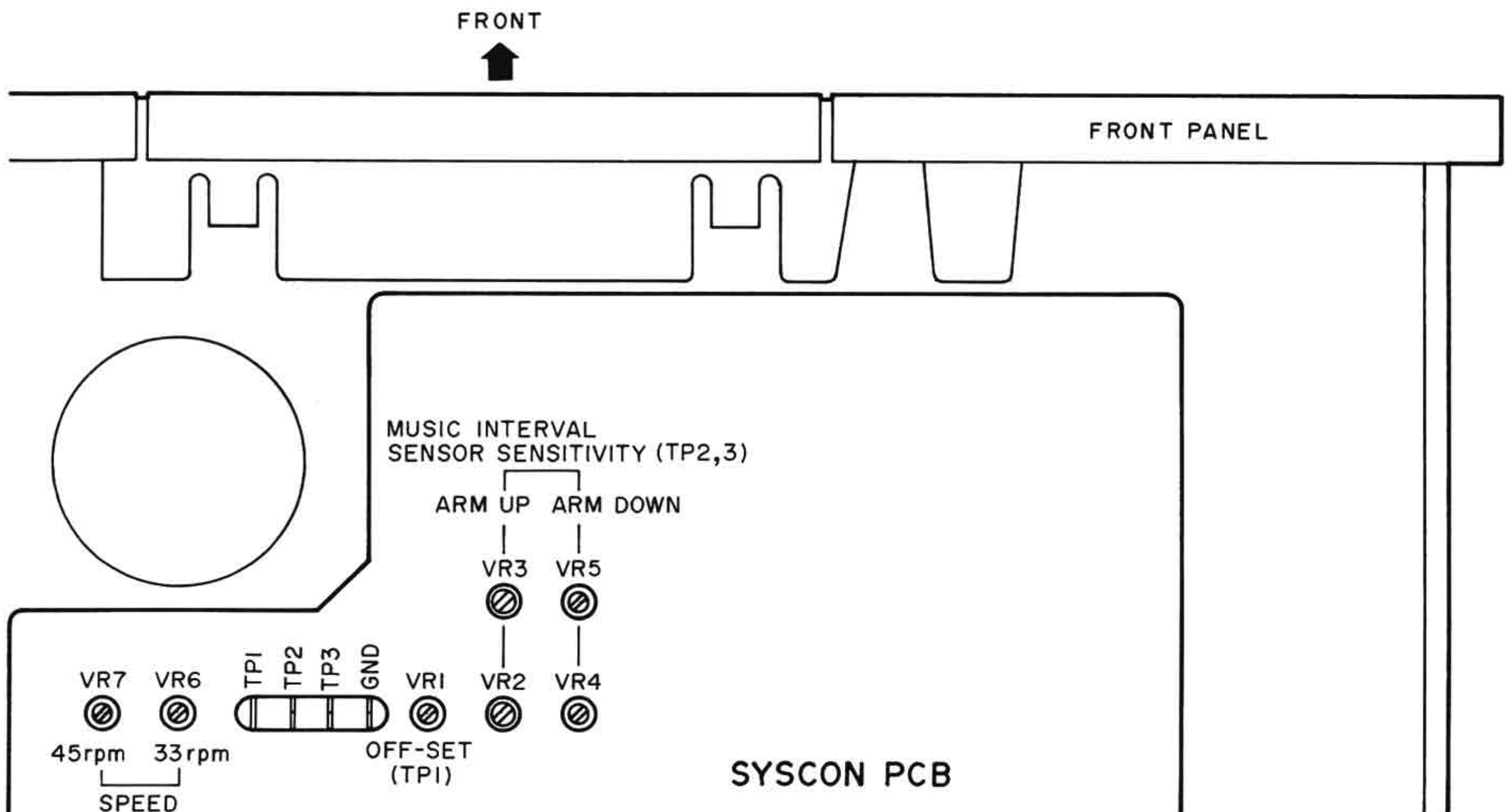

Fig. 6-5 Syscon PCB ADJ Points (Bottom View)

- 1) Turn on the power and place a 30 cm record on the platter.
- 2) Disconnect the connector P6 on AUDIO P.C BOARD.
- 3) Connect an oscilloscope (or digital voltmeter) to

- TP-1 on SYSTEM CONTROL P.C BOARD, and adjust VR1 so that the voltage is 0V + 50 mV.
- NOTE:** Turn VR2 and VR3 fully clockwise prior to this adjustment in case of having difficulty caused by hum noise.

6-5 TRACKING SENSOR SENSITIVITY ADJUSTMENT (Refer to Figs. 6-3 & 6-5)

- 1) Turn on the power and connect an oscilloscope (or digital voltmeter) to TP3 on AUDIO P.C BOARD.
- 2) Adjust VR1 so that the voltage is $2.0V \pm 0.2V$.

6-6 MUSIC INTERVAL SENSOR SENSITIVITY ADJUSTMENT (Refer to Fig. 6-5)

- 1) Turn on the power and place a 30 cm record on the platter.
- 2) Connect a dual beam oscilloscope to TP2 (CH1) and TP3 (CH2).
- 3) Press the START button to play, then press FWD button to move the Tone Arm to the position above the non-groove surface.
- 4) Adjust VR2 and VR3 (on SYSCON P.C BOARD) so that the minimum voltage of the fluctuating waveform on each CH is $1.5V \pm 0.2V$. (See NOTE)
- 5) Next press the Arm Lifter button to make the stylus descends on the non-groove surface, and in the same manner as item 4) adjust VR4 and VR5 so that the minimum voltage is $3.5V \pm 0.2V$. (See NOTE)

NOTE: For the models using SYSTEM CONTROL PCB P1035A501A (4ED), the voltages in item 4) and 5) have to be adjusted as follows.

- Item 4) $\rightarrow 1.05 \pm 0.05 V$
- Item 5) $\rightarrow 2.5 \pm 0.1 V$

6-7 SPEED ADJUSTMENT (Refer to Fig. 6-5)

- 1) Turn on the power and set the speed selector to 33 rpm.
- 2) Playback the Test Record (33-1/3 rpm, 1000 Hz), and adjust VR6 on SYSCON P.C BOARD so that the speed is $1000 Hz \pm 2 Hz$.
- 3) Set the speed selector to 45 rpm and adjust VR7 so that the speed is $1350 Hz \pm 2 Hz$.

NOTE: Speeds can be adjusted also by using a stroboplate and adjust VR6 (33 rpm) and VR7 (45 rpm) so that the strobe according to your area comes to stand-still at each speed.

6-8 LEAD-IN POSITION ADJUSTMENT (Refer to Fig. 6-6)

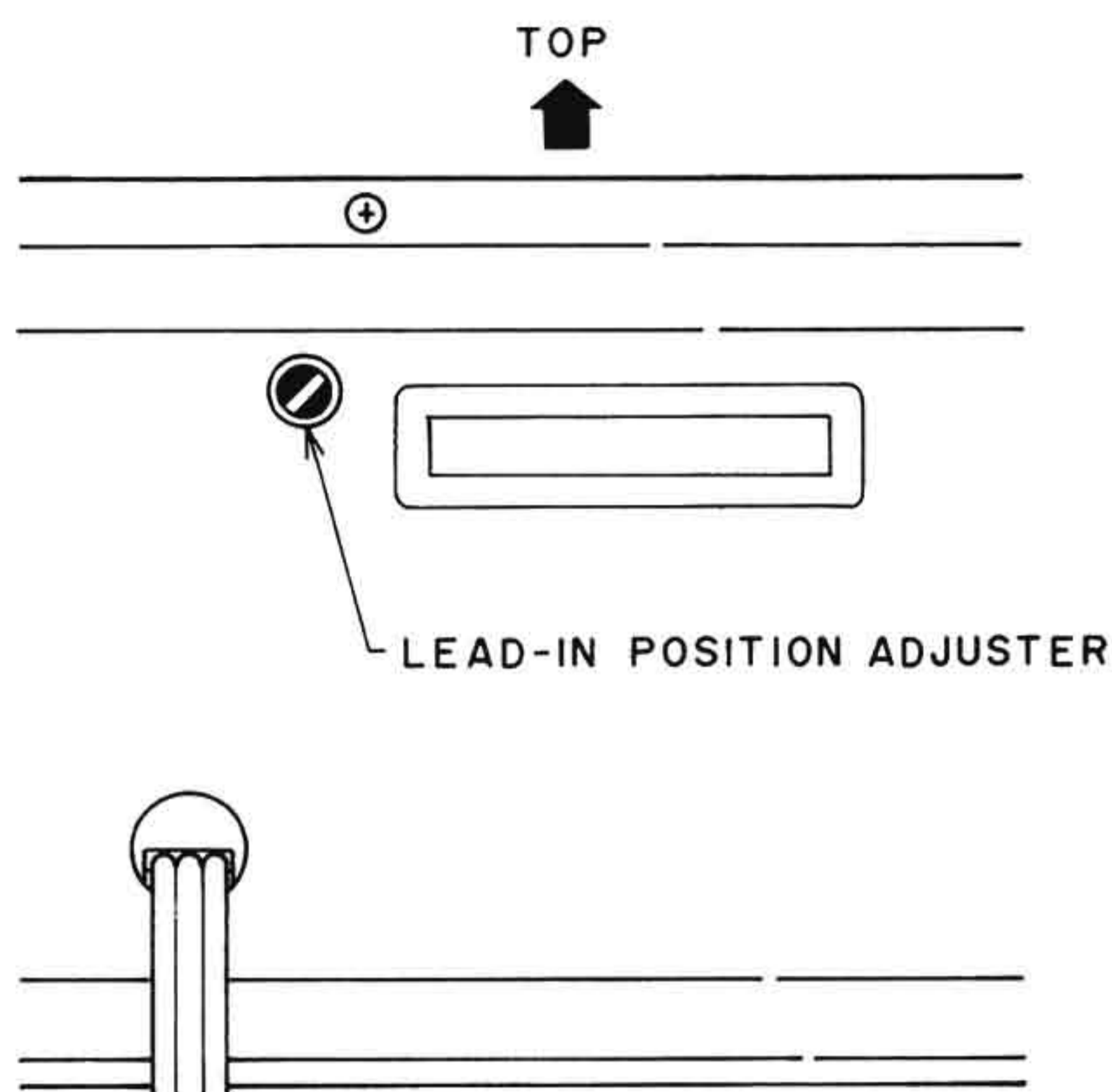

Fig. 6-6 Lead-in Position ADJ Point (Rear View)

- 1) Turn off the power and set the speed selector to AUTO.
- 2) Place a 17 cm record on the platter and play.
- 3) Confirm the position where the stylus descends.
- 4) If this lead-in position is incorrect, it can be adjusted by turning the Lead-in Position Adjuster shown in Fig. 12 clockwise or counter-clockwise.
Clockwise: To make the stylus descends away from the spindle.
Counter-clockwise: To make the stylus descends towards the spindle.

6-9 PLAY SW (SW902) POSITION ADJUSTMENT (Refer to Fig. 6-7)

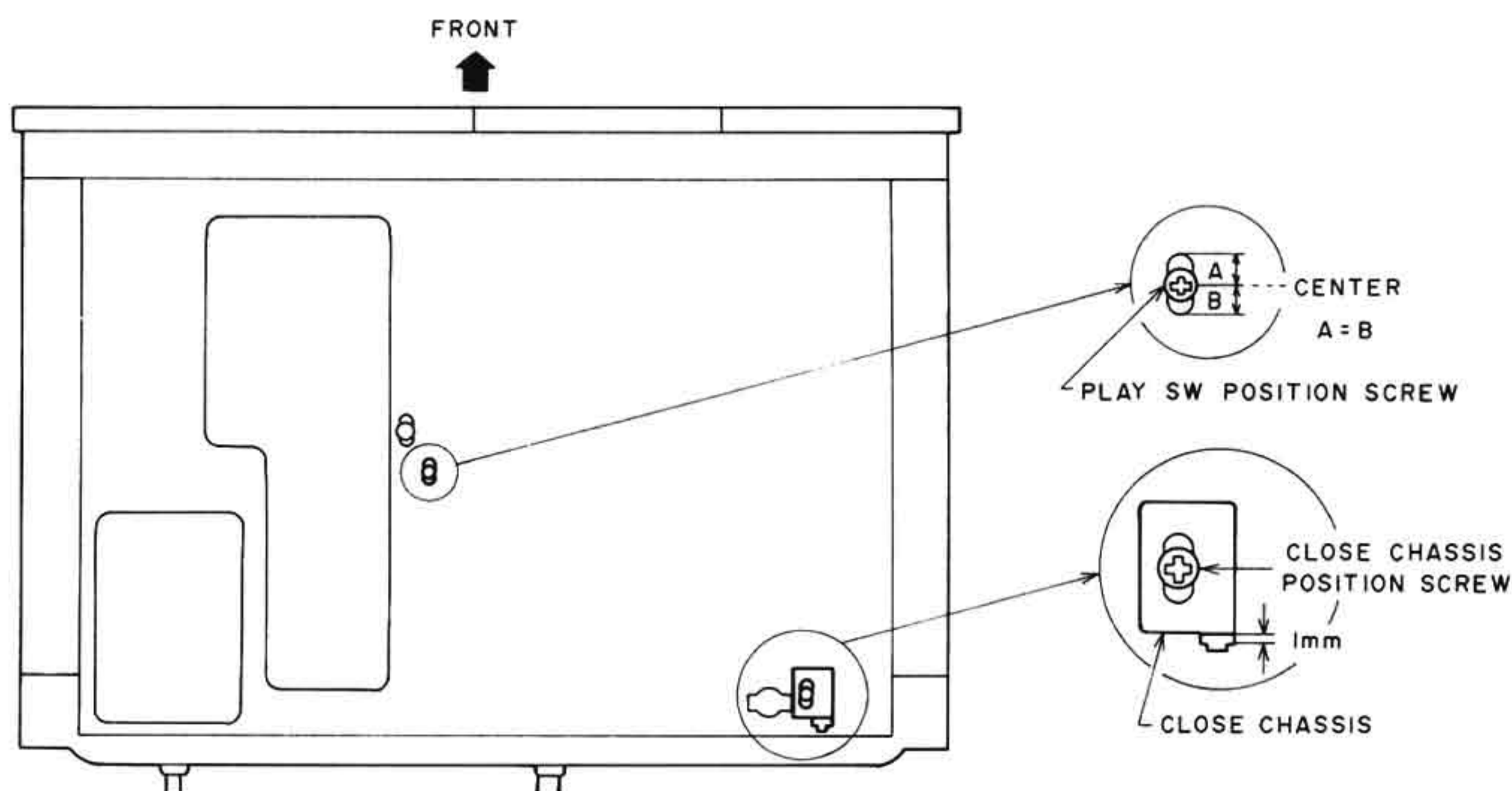

Fig. 6-7 Play SW/Close Chassis Position ADJ (Bottom View)

- 1) This adjustment is not necessary in normal conditions, unless this PLAY SW is replaced or mis-adjusted.
- 2) Tighten the Play SW Position Screw in the center of the screw hole as shown in Fig. 6-7.

6-10 CLOSE CHASSIS (FOR CLOSE SW: SW2 on LIMIT PCB) POSITION ADJUSTMENT (Refer to Fig. 6-7)

- 1) This adjustment is not necessary in normal conditions, unless this CLOSE SW is replaced or mis-adjusted.
- 2) Tighten the Close Chassis Position Screw in the position in which there is 7 mm distance between the Close Chassis and the hole on the Bottom Cover as shown in Fig. 6-7.

VII. P.C BOARD TITLES AND IDENTIFICATION NUMBERS

P.C Board Title		P.C Board Number
System Control	P.C Board	P1035A501A
Audio	P.C Board	P1035A501B
Power Supply	P.C Board	P1035A501C
Key Board (A)	P.C Board	P1035A501D
Key Board (B)	P.C Board	P1035A501E
Relay	P.C Board	P1035A501F
Position Sensor (LED)	P.C Board	P1035A501G
Position Sensor (PTR)	P.C Board	P1035A501H
Limit	P.C Board	P1035A501J
Program IND.	P.C Board	P1035A501K
Rest	P.C Board	P1035A501L
IND.	P.C Board	P1035A501M
Slide	P.C Board	P1035A501N
Tracking	P.C Board	P1035A501P
IC (A)	P.C Board	P1035A501Q
IC (B)	P.C Board	P1035A501R
IC (C)	P.C Board	P1035A501S

SECTION 2

PARTS LIST

TABLE OF CONTENTS

RECOMMENDED SPARE PARTS 25

1. SYSTEM CONTROL P.C BOARD BLOCK 25

2. ASSEMBLY BLOCK (1) 26

3. ASSEMBLY BLOCK (2) 28

4. FINAL ASSEMBLY BLOCK 30

INDEX 32

Resistors and Capacitors which are not listed in this parts list, please refer to COMMON LIST FOR SERVICE PARTS.

ATTENTION

1. When placing an order for parts, be sure to list the parts no. model no., and description. There are instances in which if any of this information is omitted, parts cannot be shipped or the wrong parts will be delivered.
2. Please be careful not to make a mistake in the parts no. If the parts no. is in error, a part different from the one ordered may be delivered.
3. Because parts number and parts unit supply in the Preliminary Parts List may be partially changed, please use this parts list for all future reference.

HOW TO USE THIS PARTS LIST

1. This Parts List shows the parts that are considered necessary for repairs. Other parts, such as resistors and capacitors, are shown in the "Common List for Service Parts". Select and order such parts from the "Common List for Service Parts".
2. The Recommended Spare Parts shows those parts in the Parts List which are considered particularly important for service.
3. Parts not shown in the Parts List and "Common List for Service Parts" will not be supplied in principle.
4. How to read list
 - a) Mechanism Block
 - b) P.C Board Block

2. HEAD BASE BLOCK

REF. NO.	PARTS NO.	DESCRIPTION
2-1x	BH-T2023A320A	HEAD BASE BLOCK GX-F66R
2-2	HP-H2206A010A	HEAD R/P PR4-8FU C
2-3	ZS-477876	PAN20x03STL CMT
2-4	ZS-536488	BID20x08STL CMT
2-5	ZG-402895	CS ANGLE ADJUST SPRING

SP (Service Parts) Classification

A small "x" indicates the inability to show that particular part in the Photo or Illustration.

This number corresponds with the individual parts index number in that figure

This number corresponds with the Figure Number

6. SYS. CON. P.C BOARD BLOCK

REF. NO.	PARTS NO.	DESCRIPTION
6-1	BA-T2034A070A	PC SYS CON BLK GX-F44R
6-IC1	EI-324536	IC HD14049BP
6-IC2	EI-336801	IC MB8841-564M
6-IC3	EI-331661	IC SN7405N
6-IC4	EI-336725	IC M54527P
6-TR1to4	ET-200985	TR 2SC2603 F,G
6-TR5to28	ET-554657	TR 2SA733A P,Q
6-D1	ED-318292	D SILICON H 1S2473T-77 T26
6-D2to4	ED-308952	D GERMA V 1K34A-LR F07
6-D5to10	ED-318292	D SILICON H 1S2473T-77 T26
6-X1	EI-318384	OSC X'TAL NC-18C 3.579545MHZ

SP (Service Parts) Classification

This reference numbers corresponds with symbol numbers of Schematic Diagrams.

5. Both the kind of part and installation position can be determined by the Parts Number. To determine where a parts number is listed, utilize Parts Index at end of Parts List. It is necessary first of all to find the Parts Number. This can be accomplished by using the Reference Number listed at right of parts number in the Parts Index.

WARNING

△ INDICATES SAFETY CRITICAL COMPONENTS. FOR CONTINUED SAFETY, REPLACE SAFETY CRITICAL COMPONENTS ONLY WITH MANUFACTURER'S RECOMMENDED PARTS.

AVERTISSEMENT

△ IL INDIQUE LES COMPOSANTS CRITIQUES DE SURETE. POUR MAINTENIR LE DEGRE DE SECURITE DE L'APPAREIL NE REMPLACER LES COMPOSANTS DONT LE FONCTIONNEMENT EST CRITIQUE POUR LA SECURITE QUE PAR DES PIECES RECOMMANDEES PAR LE FABRICANT.

RECOMMENDED SPARE PARTS

Because, if the parts listed below are on hand, almost any repair can be accomplished, we suggest that you stock these Recommended Spare Parts Items.

NO.	PARTS NO.	DESCRIPTION
1	N BM-351155	MOTOR MMI-5P2R (M903)
2	N BM-351154	MOTOR MMN-5C2R (M902)
3	N BM-349296	MOTOR MMN-5C2RG (M901)
4	N BT-349746	△ TRANS POWER APT-77-20 (A)
5	N BT-351148	△ TRANS POWER APT-77-10 (J)
6	N BT-351149	△ TRANS POWER APT-77-30 (C)
7	N BT-351150	△ TRANS POWER APT-77-40 (E)
8	N BT-351151	△ TRANS POWER APT-77-50 (B,S)
9	N BT-351147	△ TRANS POWER APT-77-70 (U)
10	ED-322238	△ D SILICON 1B4B41 100/1.0A
11	ED-562386	D GERMA H 1S188AM
12	ED-562386	D GERMA H 1S188AM
13	ED-562397	D GERMA H 1S188FM1
14	ED-337379	D LED NJL1102EH INFRARED
15	ED-337894	D LED SLP444D01 AMBER
16	ED-337892	D LED SLP451D AMBER
17	ED-301911	D SILICON H DS448
18	ED-344280	D SILICON H GMA-01-FY2 F05
19	ED-306724	D SILICON S5277B 100/1.0A
20	N ED-346605	D ZENER H HZ7 C2
21	N EF-300602	△ FUSE FST3100 T 250V 0.63A (E,B,S)
22	EI-315243	△ IC TA78005P
23	EI-347758	△ IC TA78012AP
24	N EI-349634	△ IC μPC7912H
25	EI-336761	IC LA6458S
26	EI-201940	IC NJM4558S
27	N EI-351162	IC P1035
28	EI-344461	IC TA75393S
29	EI-324255	IC TL082 CP
30	EI-349372	OSC CE CSA4.00MG 4MHZ
31	N EM-351174	IND LE SL-4179
32	N EP-351177	SOLENOID 0531PLT 12V
33	ER-318647	△ R FUSE ERD2FC S10 1/4W 4R7J
34	ES-347048	SW PUSH SCL101P 1-01-02N
35	N ES-349639	SW PUSH SCL101P-R 1-01-02N
36	ES-344473	SW PUSH SCL101T 1-01-02N
37	ES-348463	SW SLIDE 00120297 01-2 (U)
38	N ES-349276	SW SLIDE 00230873 2-02-03S
39	ES-336780	SW TACT KHH10902
40	ES-349474	SW TACT KHH10910
41	ET-337378	PHOTO SENSOR NJL7260E
42	ET-344472	PHOTO SENSOR ON1128AK
43	N ET-330535	TR FET 2SK246 Y,GR
44	N ET-325501	TR 2SA1015 O,Y
45	ET-347738	TR 2SA1282A E,F
46	N ET-307234	TR 2SC1815 Y,GR
47	ET-349272	TR 2SC3242A E,F
48	ET-338565	TR 2SD1302 R,S
49	EV-336853	R S-FIX H KVSF807U 3P 103
50	EV-336843	R S-FIX H KVSF807U 3P 303
51	EV-336847	R S-FIX H KVSF807U 3P 502
52	EV-344465	R S-FIX H TM8KV2-3S 3P 0.50W 203
53	N EV-347946	R S-FIX H TM8KV3-3S 3P 0.3W 503
54	N	BELT MAIN MOTOR
55	N MB-351070	BELT SLIDE MOTOR
56	MB-613260	BELT WIND
57	MB-344538	BELT 1.2×D26.0CRHS60
58	N MB-349696	SYNCHRO BELT 140M×L3.2
59	N TP-351090B	TABLE SHEET (B)

“NOTE” N: New Parts

SYMBOL FOR DESTINATION

- A : AAL (U.S.A)
- B : UK (England)
- C : CSA (Canada)
- J : JPN (Japan)
- S : SAA (Australia)
- U : U/T (Universal Area)
- E : CEE (Europe)

1. SYSTEM CONTROL P.C BOARD BLOCK

REF. NO.	PARTS NO.	DESCRIPTION
1-1U	BA-P1035A060A	PC SYSCON BLK AP-M77-C(U) (U,J,C)
1-1A	BA-P1035A060B	PC SYSCON BLK AP-M77-A (A)
1-1E	BA-P1035A060C	PC SYSCON BLK AP-M77-C (E) (E,B,S)

SYSTEM CONTROL P.C BOARD

1-IC1	EI-336761	IC LA6458S
1-IC2	EI-344461	IC TA75393S
1-IC3	EI-324255	IC TL082 CP
1-IC4,5	EI-344461	IC TA75393S
1-IC6	EI-336761	IC LA6458S
1-IC7	EI-351162	IC P1035
1-TR1	ET-307234	TR 2SC1815 Y,GR
1-TR2	ET-325501	TR 2SA1015 O,Y
1-TR3to6	ET-307234	TR 2SC1815 Y,GR
1-TR7	ET-349272	△ TR 2SC3242A E,F
1-TR8	ET-347738	△ TR 2SA1282A E,F
1-TR9	ET-325501	TR 2SA1015 O,Y
1-TR10	ET-307234	TR 2SC1815 Y,GR
1-TR11	ET-325501	TR 2SA1015 O,Y
1-TR12,13	ET-338565	TR 2SD1302 R,S
1-TR14to17	ET-307234	TR 2SC1815 Y,GR
1-TR18	ET-330535	TR FET 2SK246 Y,GR
1-TR19	ET-307234	TR 2SC1815 Y,GR
1-TR20	ET-325501	TR 2SA1015 O,Y
1-TR21	ET-349272	△ TR 2SC3242A E,F
1-TR22	ET-347738	△ TR 2SA1282A E,F
1-TR23	ET-307234	TR 2SC1815 Y,GR
1-TR24	ET-347738	TR 2SA1282A E,F
1-TR25	ET-349272	TR 2SC3242A E,F
1-TR26	ET-325501	TR 2SA1015 O,Y
1-TR27,28	ET-307234	TR 2SC1815 Y,GR
1-TR29	ET-349272	TR 2SC3242A E,F
1-TR30	ET-307234	TR 2SC1815 Y,GR
1-TR31	ET-338565	TR 2SD1302 R,S
1-TR32	ET-307234	TR 2SC1815 Y,GR
1-TR33	ET-338565	TR 2SD1302 R,S
1-TR34to38	ET-307234	TR 2SC1815 Y,GR
1-D1to8	ED-301911	D SILICON H DS448
1-D9	ED-562397	D GERMA H 1S188FM1
1-D10	ED-562386	D GERMA H 1S188AM
1-D11to14	ED-301911	D SILICON H DS448
1-D15,16	ED-306724	D SILICON S5277B 100/1.0A
1-D17to20	ED-301911	D SILICON H DS448
1-D21	ED-346605	D ZENER H HZ7 C2
1-D22,23	ED-562386	D GERMA H 1S188AM
1-D24	ED-301911	D SILICON H DS448
1-VR1	EV-336853	R S-FIX H KVSF807U 3P 103
1-VR2,3	EV-347946	R S-FIX H TM8KV3-3S 3P 0.3W 503
1-VR4,5	EV-336843	R S-FIX H KVSF807U 3P 303
1-VR6	EV-336853	R S-FIX H KVSF807U 3P 103
1-VR7	EV-336847	R S-FIX H KVSF807U 3P 502
1-L1	EO-345992	COIL FIX 1 EL0606RR T05 680J
1-X1	EI-349372	OSC CE CSA4.00MG 4MHZ
1-SR1	EH-351158	COMP R EXB-P84 223K
1-R5,6	ER-696306	R MF H 1/4W 2001F
1-R86	ER-265048	R OMF H 2W 271J

AUDIO P.C BOARD

1-IC1B	EI-201940	IC NJM4558S
1-TR1B	ET-330535	TR FET 2SK246 Y,GR
1-TR2B,3B	ET-338565	TR 2SD1302 R,S
1-VR1B	EV-344465	R S-FIX H TM8KV2-3S 3P 0.50W 203
1-VR2B,3B	EV-336847	R S-FIX H KVSF807U 3P 502

POWER SUPPLY P.C BOARD

1-D1C	ED-322238	△ D SILICON 1B4B41 100/1.0A
1-FR1C	ER-318647	△ R FUSE ERD2FC S10 1/4W 4R7J

REF. NO.	PARTS NO.	DESCRIPTION
KEY BOARD (A) P.C BOARD		
1-D1Dto11D	ED-344280	D SILICON H GMA-01-FY2 F05
1-SW1Dto11D	ES-336780	SW TACT KHH10902
KEY BOARD (B) P.C BOARD		
1-D1Eto5E	ED-344280	D SILICON H GMA-01-FY2 F05
1-SW1Eto4E	ES-336780	SW TACT KHH10902
1-SW5E	ES-349474	SW TACT KHH10910
POSITION SENSOR (LED)		
1-D1G,2G	ED-337393	D LED NJL1102EH INFRARED
POSITION SENSOR (PTR) P.C BOARD		
1-PH1H,2H	ET-337378	PHOTO SENSOR NJL7260E
LIMIT P.C BOARD		
1-SW1J,2J	ES-347048	SW PUSH SCL101P 1-01-02N
PROGRAM IND P.C BOARD		
1-IND1K	EM-351174	IND LE SL-4179
RESET P.C BOARD		
1-SW1L	ES-344473	SW PUSH SCL101T 1-01-02N
1-C1L	EC-300193	C EC V F05 NP SM 100M 16DC
IND P.C BOARD		
1-D1Mto3M	ED-337894	D LED SLP444D01 AMBER
SLIDE P.C BOARD		
1-SW1N,2N	ES-349276	SW SLIDE 00230873 2-02-03S
TRACKING P.C BOARD		
1-PH1P	ET-344472	PHOTO SENSOR ON1128AK
IC (A) P.C BOARD		
1-IC1Q	EI-347758	Δ IC TA78012AP
IC (B) P.C BOARD		
1-IC1R	EI-315243	Δ IC TA78005P
IC (C) P.C BOARD		
1-IC1S	EI-349634	Δ IC μPC7912H

2. ASSEMBLY BLOCK (1)

REF. NO.	PARTS NO.	DESCRIPTION
CHASSIS UPPER BLOCK		
2-1	MR-308836	PULLEY
2-2	MB-349221	BUSH GUIDE
2-3	MB-344538	BELT 1.2×D26.0CRHS60
2-4	ZG-313046	SP T1-5.0/0.55-28.0 T1-159
2-5	EZ-349232	STRING WIRE
2-6	EZ-349230	WIRE REJECT
2-7	MI-351053	GEAR PULLEY (1)
2-8	ZW-620234	PW45×130×100NYL
2-9	MB-349696	SYNCHRO BELT 140M×L3.2
2-10	ZW-357164	RING E230SUP CMT
2-11	MI-351055	GEAR PULLEY (3)
2-12	ZW-324147	PW31×130×100NYL
2-13	ZW-322525	PW41×070×020PBR
2-14	MI-351056	GEAR DRIVE (1)
2-15	ZS-356815	6SET30×060SCM PKR HP
2-16	MS-351035	SHAFT DRIVE (1)
2-17	MI-351063	GEAR DRIVE (2)
2-18	EP-351177	SOLENOID 0531PLT 12V (SL901)
2-19	TP-351178	TONE ARM W/CARTRIDGE
		AP-M77
2-20	TP-P1035A160A	CHASSIS GEAR BLK AP-M77-C
2-21	TP-P1035A170A	ARM ELEVATION BLK AP-M77-C
DUST COVER BLOCK		
2-22	BC-P1035A100A	DUST COVER BLK AP-M77-C
2-23	SP-351082	COVER FRONT
2-24	ET-344472	PHOTO SENSOR ON1128AK (PH-1)
MOTOR ARM BLOCK		
2-25	BM-349296	MOTOR MMN-5C2RG (M901)

NOTE: Parts listed in 1 to 25 on the exploded view and list are normally stocked for replacement purpose.

The remaining parts shown in this manual are not normally stocked, because they are not seldom required for routine service.

ASSEMBLY BLOCK (1)

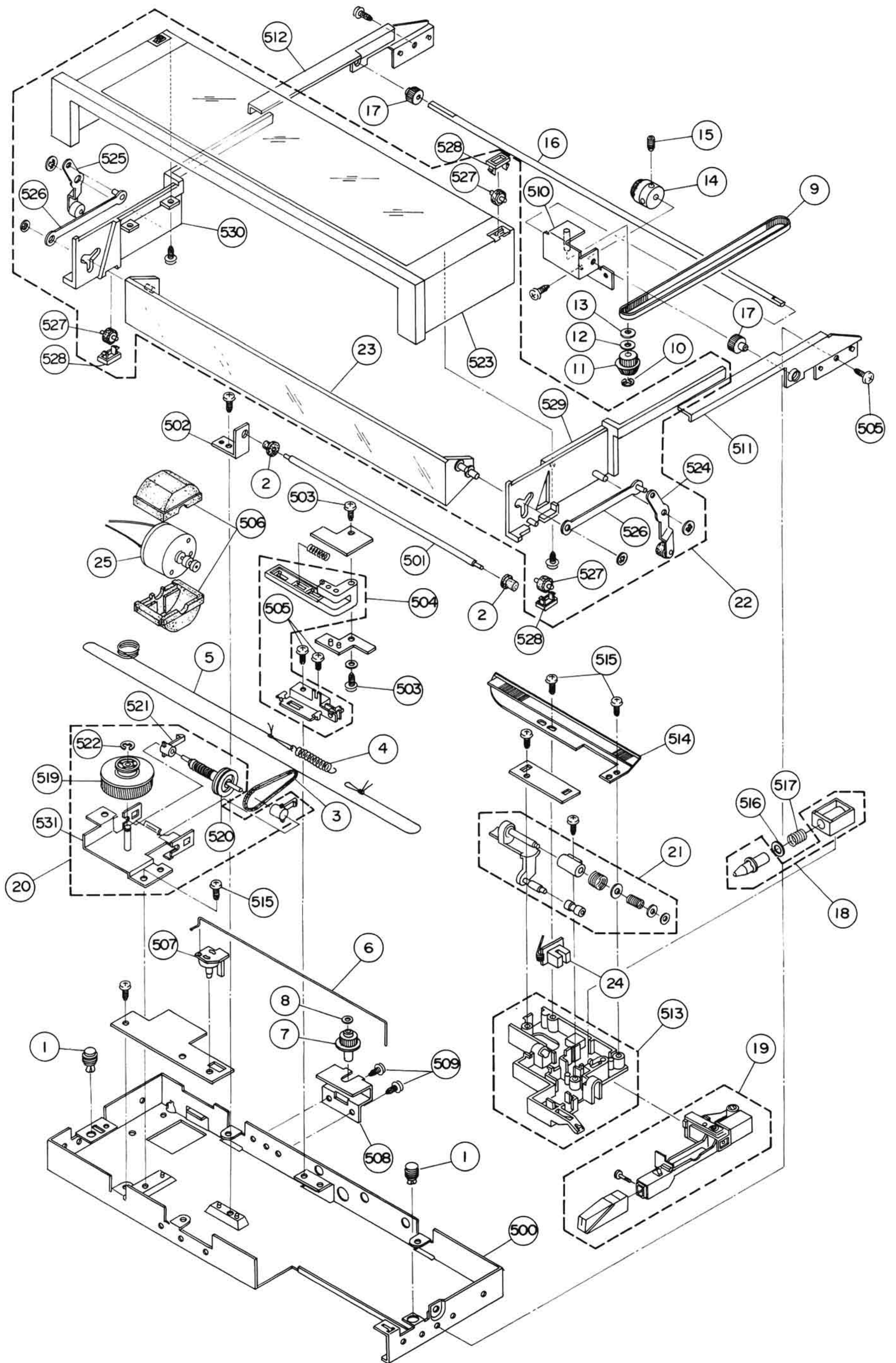

3. ASSEMBLY BLOCK (2)

REF. NO.	PARTS NO.	DESCRIPTION
ASSEMBLY BLOCK		
3-1	TP-351543	INSULATOR
3-2	MI-351054	GEAR PULLEY
3-3U	BT-351147	△ TRANS POWER APT-77-70 (U)(T901)
3-3J	BT-351148	△ TRANS POWER APT-77-10 (J)(T901)
3-3C	BT-351149	△ TRANS POWER APT-77-30 (C)(T901)
3-3A	BT-349746	△ TRANS POWER APT-77-20 (A)(T901)
3-3E	BT-351150	△ TRANS POWER APT-77-40 (E)(T901)
3-3B	BT-351151	△ TRANS POWER APT-77-50 (B,S)(T901)
3-4U	SP-351038A	PANEL REAR (A)(U,J,C,A)
3-4E	SP-351038B	PANEL REAR (B)(E,B,S)
3-5	EW-353156	CORD P1035A UL 3P AUDIO
3-6	ES-348463	△ SW SLIDE 00120297 01-2 (U)(SW901)
3-7U	EW-349550	△ AC CORD 2CORES IP-224, VFF PL-7 U/T (U)
3-7J	EW-349549	△ AC CORD 2CORES KP-224, VFF PL-7 J (J)
3-7C	EW-207742	△ AC CORD 2 CORES VM-0238, SPT-1 UC (C,A)
3-8	EZ-631945	STRAIN RELIEF SR-4N-4
3-9	EZ-631945	STRAIN RELIEF SR-4N-4(U,J,C,A)
3-10x	EJ-301513	△ SOCKET INLET S-I6453 E 2P (E,B,S)(J901)
3-11x	TA-328841	COVER 2P INLET
3-12x	ZW-305013	RV POP32 (A)
3-13x	EF-300602	△ FUSE FST3100 T 250V 0.63A (E,B,S)(F1)
3-14	EF-300602	△ FUSE FST3100 T 250V 0.63A (E,B,S)(F2)
3-15	MB-349696	SYNCHRO BELT 140MXL3.2
3-16	MI-351053	GEAR PULLEY (1)
3-17	TP-349500	PLATE STYLUS CHANGE
3-18	BC-P1035A120A	COVER UPPER BLK AP-M77-C
3-19	SA-B351636X2	RUBBER FOOT (R) PART
3-20	SA-B351636X1	RUBBER FOOT (L) PART
3-21	ZS-345272	ST BR30×06STL BNI
3-22	MI-351063	GEAR DRIVE (2)
3-23	MI-351205	GEAR FRONT
3-24	ZW-357164	RING E230SUP CMT
3-25	MZ-351194	RACK
3-26	ES-349639	SW PUSH SCL101P-R 1-01-02N
IC (B) P.C BOARD		
3-27	EI-315243	△ IC TA78005P (IC1)
IC (A) P.C BOARD		
3-28	EI-347758	△ IC TA78012AP (IC1)
IC (C) P.C BOARD		
3-29	EI-349634	△ IC μPC7912H (IC1)

NOTE: Parts listed in 1 to 29 on the exploded view and list are normally stocked for replacement purpose.

The remaining parts shown in this manual are not normally stocked, because they are not seldom required for routine service.

SYMBOL FOR DESTINATION

- A : AAL (U.S.A)
- B : UK (England)
- C : CSA (Canada)
- J : JPN (Japan)
- S : SAA (Australia)
- U : U/T (Universal Area)
- E : CEE (Europe)

4. FINAL ASSEMBLY BLOCK

REF. NO.	PARTS NO.	DESCRIPTION
CABINET BLOCK		
4-1U	BD-P1035A030A	PANEL FRONT BLK AP-M77-C(U) (U,J,C,E,B,S)
4-1A	BD-P1035A030B	PANEL FRONT BLK AP-M77-C(A)
4-2	SK-351088B	KNOB PROGRAM (B)
4-3	SE-351040	WINDOW LED
4-4	SK-351057	KNOB START
4-5	SK-351058	KNOB DOOR
4-6	SK-349555	KNOB FORWARD
4-7	MZ-P1035A040A	GEAR BLK AP-M77-C
4-8	MB-613260	BELT WIND
4-9	MR-351541	PULLEY LOADING (1)
4-10	MB-351070	BELT SLIDE MOTOR
4-11	MR-351542	PULLEY LOADING (2)
4-12	TC-690952	MIDDLE GEAR
4-13	MI-351078	GEAR (3)
4-14	BM-351154	MOTOR MMN-5C2R (M902)
4-15	MR-345182	PULLEY MOTOR
4-16	TP-351091	PLATTER
4-17	TP-351030	CRANK DISK
4-18	ZG-351064	SP CRANK DISK
4-19	BM-351155	MOTOR MMI-5P2R (M903)
4-20	TP-349346	SPINDLE ASSY
4-21	ZG-313026	SP T1-5.0/0.32-16.0 T1-139
4-22	BC-351062	CABINET
4-23	MB-345351	RUBBER CUSHION
4-24	ZS-350767	SCREW
SLIDE P.C BOARD		
4-25	ES-349276	SW SLIDE 00230873 2-02-03S (SW-1,2)
LIMIT P.C BOARD		
4-26	ES-347048	SW PUSH SCL101P 1-01-02N (SW-1,2)
FINAL ASSEMBLY BLOCK		
4-27	TP-351090B	TABLE SHEET (B)
4-28	MB-351069	BELT MAIN MOTOR
4-29	TP-351042	COVER MAIN MOTOR
IND P.C BOARD		
4-30	ED-337894	D LED SLP444D01 AMBER (D1)
4-31	ED-337892	D LED SLP451D AMBER (D2)
4-32	ED-337892	D LED SLP451D AMBER (D3)
PROGRAM INDICATOR P.C BOARD		
4-33	EM-351174	IND LE SL-4179 (IND1)
KEY BOARD (B) P.C BOARD		
4-34	ES-336780	SW TACT KHH10902 (SW1-SW4)
4-35	ES-349474	SW TACT KHH10910 (SW5)
KEY BOARD (A) P.C BOARD		
4-36	ES-336780	SW TACT KHH10902 (SW1-SW11)

NOTE: Parts listed in 1 to 36 on the exploded view and list are normally stocked for replacement purpose.

The remaining parts shown in this manual are not normally stocked, because they are not seldom required for routine service.

SYMBOL FOR DESTINATION

A	: AAL (U.S.A)
B	: UK (England)
C	: CSA (Canada)
J	: JPN (Japan)
S	: SAA (Australia)
U	: U/T (Universal Area)
E	: CEE (Europe)

INDEX

PARTS NO.	REF. NO.	PARTS NO.	REF. NO.	PARTS NO.	REF. NO.	PARTS NO.	REF. NO.
BA-P1035A060A	1-1U	EI-347758	3-28	ET-347738	1-TR22	ZW-357164	2-10
BA-P1035A060B	1-1A	EI-349372	1-X1	ET-347738	1-TR24	ZW-357164	3-24
BA-P1035A060C	1-1E	EI-349634	1-IC1S	ET-347738	1-TR8	ZW-620234	2-8
BC-P1035A100A	2-22	EI-349634	3-29	ET-349272	1-TR21		
BC-P1035A120A	3-18	EI-351162	1-IC7	ET-349272	1-TR29		
BC-351062	4-22	EJ-301513	3-10x	ET-349272	1-TR25		
BD-P1035A030A	4-1U	EM-351174	1-IND1K	ET-349272	1-TR7		
BD-P1035A030B	4-1A	EM-351174	4-33	EV-336843	1-VR5		
BM-349296	2-25	EO-345992	1-L1	EV-336843	1-VR4		
BM-351154	4-14	EP-351177	2-18	EV-336847	1-VR7		
BM-351155	4-19	ER-265048	1-R86	EV-336847	1-VR2B		
BT-349746	3-3A	ER-318647	1-FR1C	EV-336847	1-VR3B		
BT-351147	3-3U	ER-696306	1-R5	EV-336853	1-VR1		
BT-351148	3-3J	ER-696306	1-R6	EV-336853	1-VR6		
BT-351149	3-3C	ES-336780	1-SW8D	EV-344465	1-VR1B		
BT-351150	3-3E	ES-336780	1-SW3E	EV-347946	1-VR3		
BT-351151	3-3B	ES-336780	1-SW7D	EV-347946	1-VR2		
EC-300193	1-C1L	ES-336780	1-SW11D	EW-207742	3-7C		
ED-301911	1-D14	ES-336780	1-SW2D	EW-349549	3-7J		
ED-301911	1-D24	ES-336780	1-SW1E	EW-349550	3-7U		
ED-301911	1-D13	ES-336780	1-SW2E	EW-353156	3-5		
ED-301911	1-D20	ES-336780	1-SW9D	EZ-349230	2-6		
ED-301911	1-D19	ES-336780	1-SW3D	EZ-349232	2-5		
ED-301911	1-D8	ES-336780	1-SW10D	EZ-631945	3-9		
ED-301911	1-D17	ES-336780	1-SW6D	EZ-631945	3-8		
ED-301911	1-D18	ES-336780	1-SW1D	MB-344538	2-3		
ED-301911	1-D5	ES-336780	1-SW4E	MB-345351	4-23		
ED-301911	1-D3	ES-336780	1-SW5D	MB-349221	2-2		
ED-301911	1-D6	ES-336780	1-SW4D	MB-349696	2-9		
ED-301911	1-D4	ES-336780	4-34	MB-349696	3-15		
ED-301911	1-D2	ES-336780	4-36	MB-351069	4-28		
ED-301911	1-D11	ES-344473	1-SW1L	MB-351070	4-10		
ED-301911	1-D7	ES-347048	1-SW2J	MB-613260	4-8		
ED-301911	1-D12	ES-347048	1-SW1J	MI-351053	2-7		
ED-301911	1-D1	ES-347048	4-26	MI-351053	3-16		
ED-306724	1-D15	ES-348463	3-6	MI-351054	3-2		
ED-306724	1-D16	ES-349276	1-SW2N	MI-351055	2-11		
ED-322238	1-D1C	ES-349276	1-SW1N	MI-351056	2-14		
ED-337379	1-D1G	ES-349276	4-25	MI-351063	2-17		
ED-337379	1-D2G	ES-349474	1-SW5E	MI-351063	3-22		
ED-337892	1-D3M	ES-349474	4-35	MI-351078	4-13		
ED-33 892	1-D2M	ES-349639	3-26	MI-351205	3-23		
ED-337892	4-32	ET-307234	1-TR23	MR-308836	2-1		
ED-337892	4-31	ET-307234	1-TR16	MR-345182	4-15		
ED-337894	1-D1M	ET-307234	1-TR15	MR-351541	4-9		
ED-337894	4-30	ET-307234	1-TR28	MR-351542	4-11		
ED-344280	1-D4E	ET-307234	1-TR27	MS-351035	2-16		
ED-344280	1-D5E	ET-307234	1-TR38	MZ-P1035A040A	4-7		
ED-344280	1-D6D	ET-307234	1-TR30	MZ-351194	3-25		
ED-344280	1-D1D	ET-307234	1-TR14	SA-B351636X1	3-20		
ED-344280	1-D5D	ET-307234	1-TR32	SA-B351636X2	3-19		
ED-344280	1-D3D	ET-307234	1-TR35	SE-351040	4-3		
ED-344280	1-D4D	ET-307234	1-TR34	SK-349555	4-6		
ED-344280	1-D7D	ET-307234	1-TR5	SK-351057	4-4		
ED-344280	1-D8D	ET-307234	1-TR3	SK-351058	4-5		
ED-344280	1-D2D	ET-307234	1-TR1	SK-351088B	4-2		
ED-344280	1-D9D	ET-307234	1-TR6	SP-351038A	3-4U		
ED-344280	1-D1E	ET-307234	1-TR19	SP-351038B	3-4E		
ED-344280	1-D10D	ET-307234	1-TR4	SP-351082	2-23		
ED-344280	1-D3E	ET-307234	1-TR36	TA-328841	3-11x		
ED-344280	1-D10	ET-307234	1-TR10	TC-690952	4-12		
ED-344280	1-D2E	ET-307234	1-TR37	TP-P1035A160A	2-20		
ED-346605	1-D21	ET-307234	1-TR17	TP-P1035A170A	2-21		
ED-562386	1-D22	ET-325501	1-TR20	TP-349346	4-20		
ED-562386	1-D10	ET-325501	1-TR26	TP-349500	3-17		
ED-562386	1-D23	ET-325501	1-TR11	TP-351030	4-17		
ED-562397	1-D9	ET-325501	1-TR2	TP-351042	4-29		
EF-300602	3-14x	ET-325501	1-TR9	TP-351090B	4-27		
EF-300602	3-13x	ET-330535	1-TR18	TP-351091	4-16		
EH-351158	1-SR1	ET-330535	1-TR1B	TP-351178	2-19		
EI-201940	1-IC1B	ET-337378	1-PH1H	TP-351543	3-1		
EI-315243	1-IC1R	ET-337378	1-PH2H	ZG-313026	4-21		
EI-315243	3-27	ET-338567	1-TR12	ZG-313046	2-4		
EI-324255	1-IC3	ET-338565	1-TR13	ZG-351064	4-18		
EI-336761	1-IC1	ET-338565	1-TR31	ZS-345272	3-21		
EI-336761	1-IC6	ET-338565	1-TR2B	ZS-350767	4-24		
EI-344461	1-IC2	ET-338565	1-TR33	ZS-356815	2-15		
EI-344461	1-IC5	ET-338565	1-TR3B	ZW-305013	3-12x		
EI-344461	1-IC4	ET-344472	1-PH1P	ZW-322525	2-13		
EI-347758	1-IC1Q	ET-344472	2-24	ZW-324147	2-12		

ABBREVIATIONS FOR SERVICE MANUAL MODEL AP-M77

ABBREVIATION	EXPLANATION
ADJ	ADJust, or ADJustment
A.M	Arm Motor
BWD	BackWarD
CD	Compact Disc
DAD	Digital Audio Disc
Dp	Decimal point
FWD	FoWarD
“H”	High (Refferring to voltage)
IPLS	Instant Program Locating System
“L”	Low (Referring to voltage)
LED	Light Emitting Diode
MI-COM	MIcroCOMputer
M.M	Main Motor
PCB	Printed Circuit Board
PTR	Photo TRansistor
RPPS	Random Program Play System
SENS	SENSor, or SENSitivity
S.M	Slide Motor
SW	SWitch
SYS-CON	SYStem CONtrol
VR	Variable Resistor