

**SERVICE MANUAL**

**PARTS LIST** 

PRIDE IN QUALITY

**AKAI SEMI-AUTOMATIC TURNTABLE**

MODEL **AP-003**

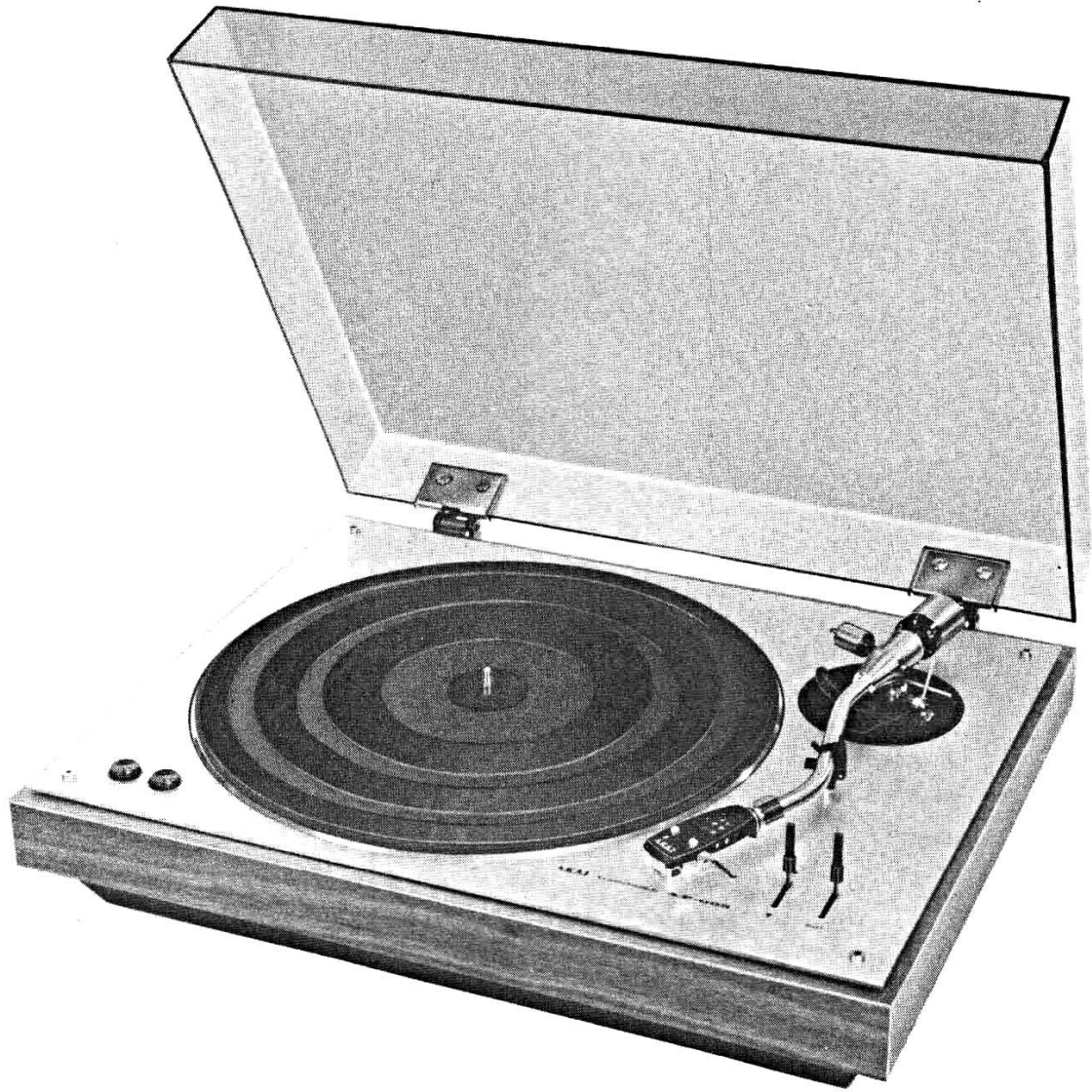

**SEMI-AUTOMATIC TURNTABLE**

**MODEL AP-003**

# I. SPECIFICATIONS

An asterisk next to a figure indicates the minimum guaranteed performance.

TYPE	Belt drive, automatic return
CARTRIDGE	MM type, AT-11 (Audio Technica)
OUTPUT VOLTAGE	4.0 mV, 1,000 Hz 50 mm/sec. *2.3 to 4.4 mV, 1,000 Hz 50 mm/sec.
FREQUENCY RESPONSE	15 Hz to 25,000 Hz
CROSS TALK	Better than 15 dB, 1,000 Hz
OUTPUT BALANCE	Within 3 dB, 1,000 Hz
COMPLIANCE	4 to $8 \times 10^{-6}$ cm/dyne
STYLUS PRESSURE	2.0 gr *2.5 gr
STYLUS TIP	0.7 mil spherical diamond tip
PICK UP ARM SYSTEM	Static-balanced type pipe arm with inside force canceller and lateral balance weight.
MOTOR	4-pole synchronous motor
TURNTABLE	301 $\phi$ aluminum alloy diecast
REVOLUTIONS	33-1/3, 45 rpm
WOW & FLUTTER	Less than 0.05% *Less than 0.13%
SIGNAL TO NOISE	Better than 52 dB *Better than 33 dB
POWER CONSUMPTION	Less than 14W
DIMENSIONS	440(W) x 124(H) x 360(D) mm (17.6" x 4.96" x 14.4")
WEIGHT	6.8 kg (14.8 lbs.)

In case of trouble, etc. necessitating disassembly, please disassemble in the order shown in photographs. Reassemble in reverse order.

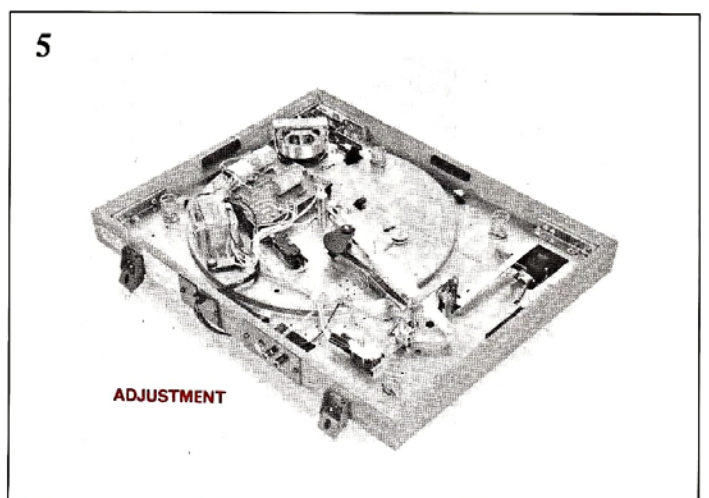
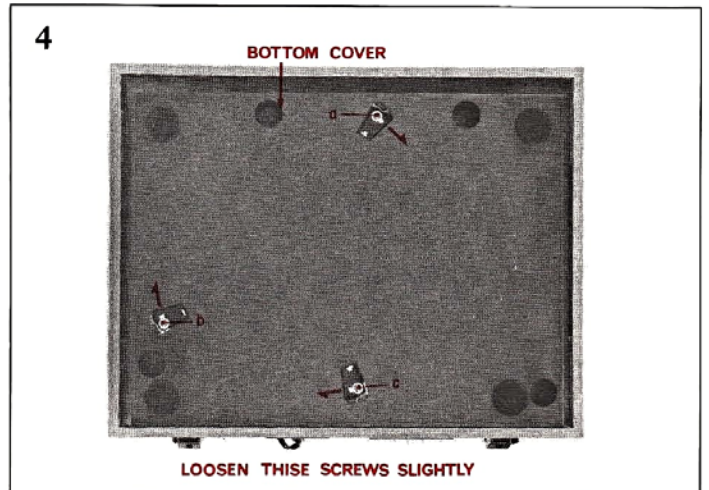
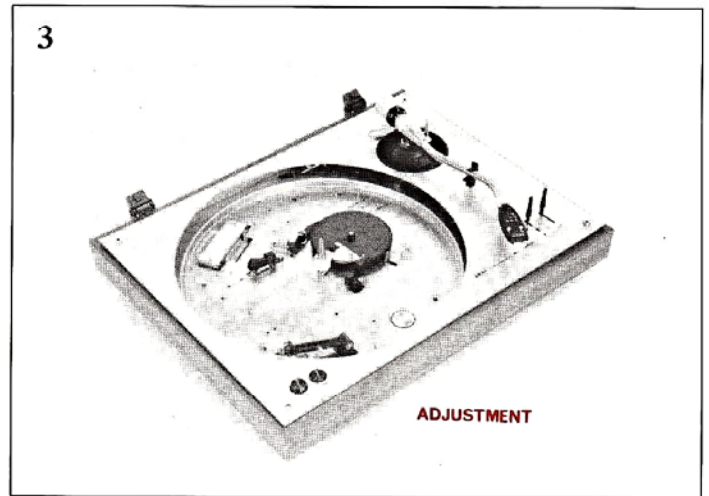
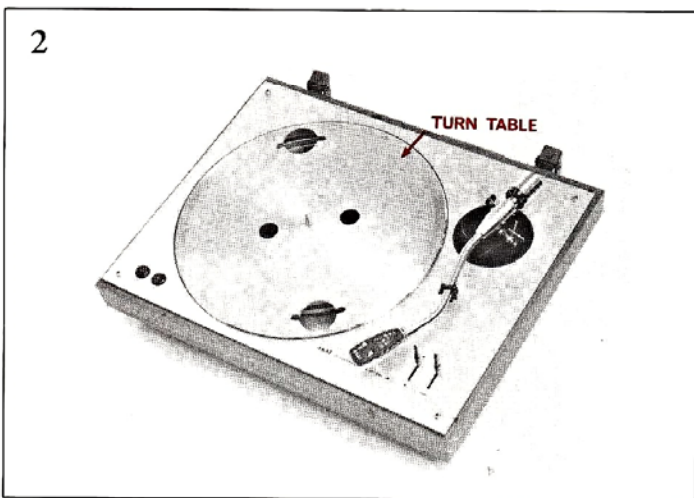

## V. PLAYER CARE

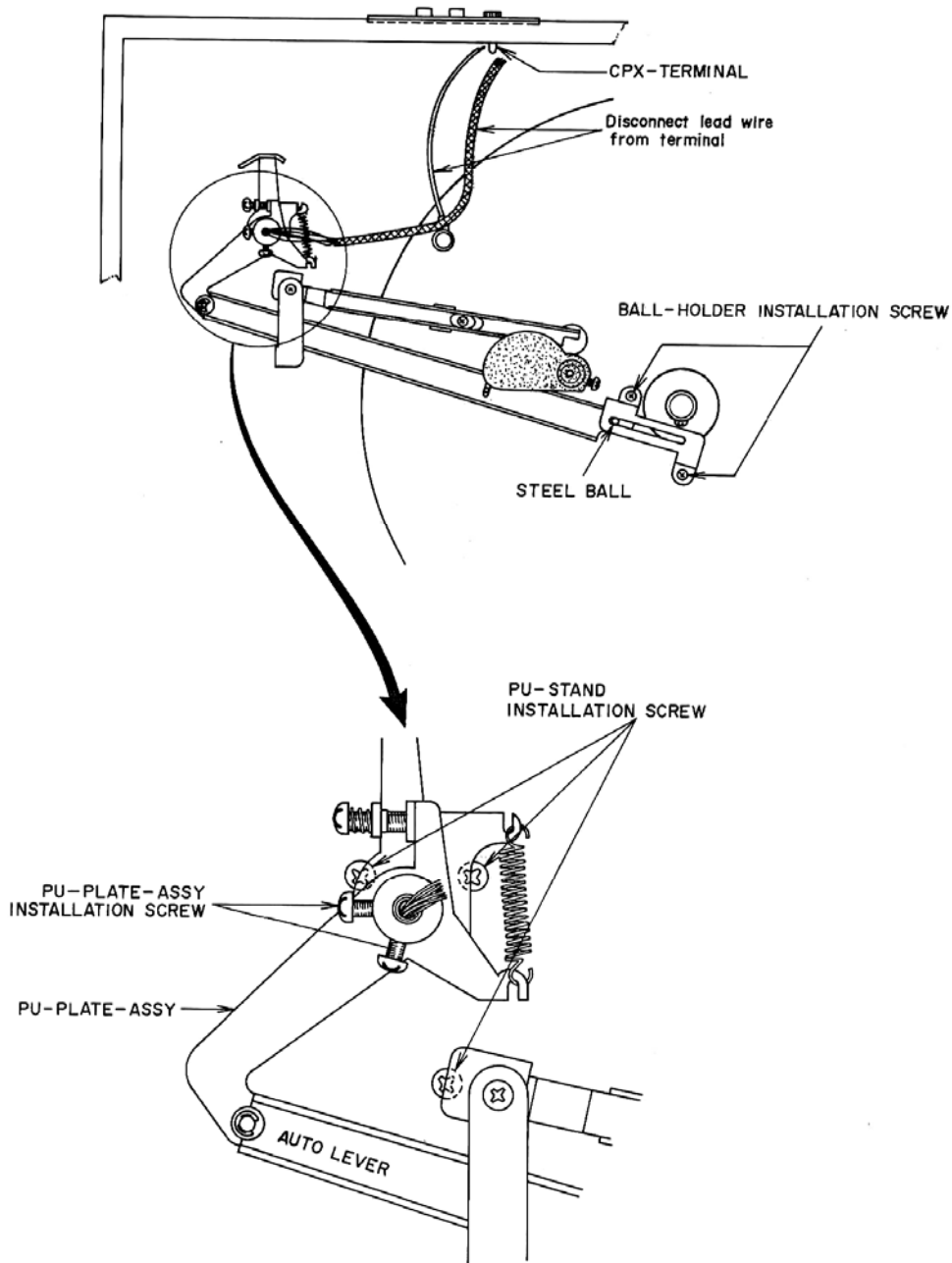

Fig. 3

### 1. TOP PANEL REMOVAL METHOD

- 1) After removal of the BOTTOM-COVER, disconnect soldered PU lead wires from CPX-TERMINAL.
- 2) Loosen the two installation screws shown in Fig. 3, and remove BALL-HOLDER.
- 3) Loosen the two PU-PLATE ASSY installation screws and remove PU-PLATE-ASSY and AUTO-LEVER from PU Arm shaft.
- 4) Loosen the three PU-STAND installation screws and gently remove PU Arm.
- 5) Loosen Panel installation screws (four special screws) and remove TOP PANEL.

NOTE: When replacing the parts listed below, remove panel, using the same procedure as outlined above.

- A. PU-ARM-ASSY
- B. PU-REST-ASSY
- C. SUB-PANEL-ASSY
- D. PUSH-BUTTON
- E. DECO-BUTTON
- F. PU-STAND
- G. STAND-BASE

# I. ARRANGEMENT OF MAIN PARTS

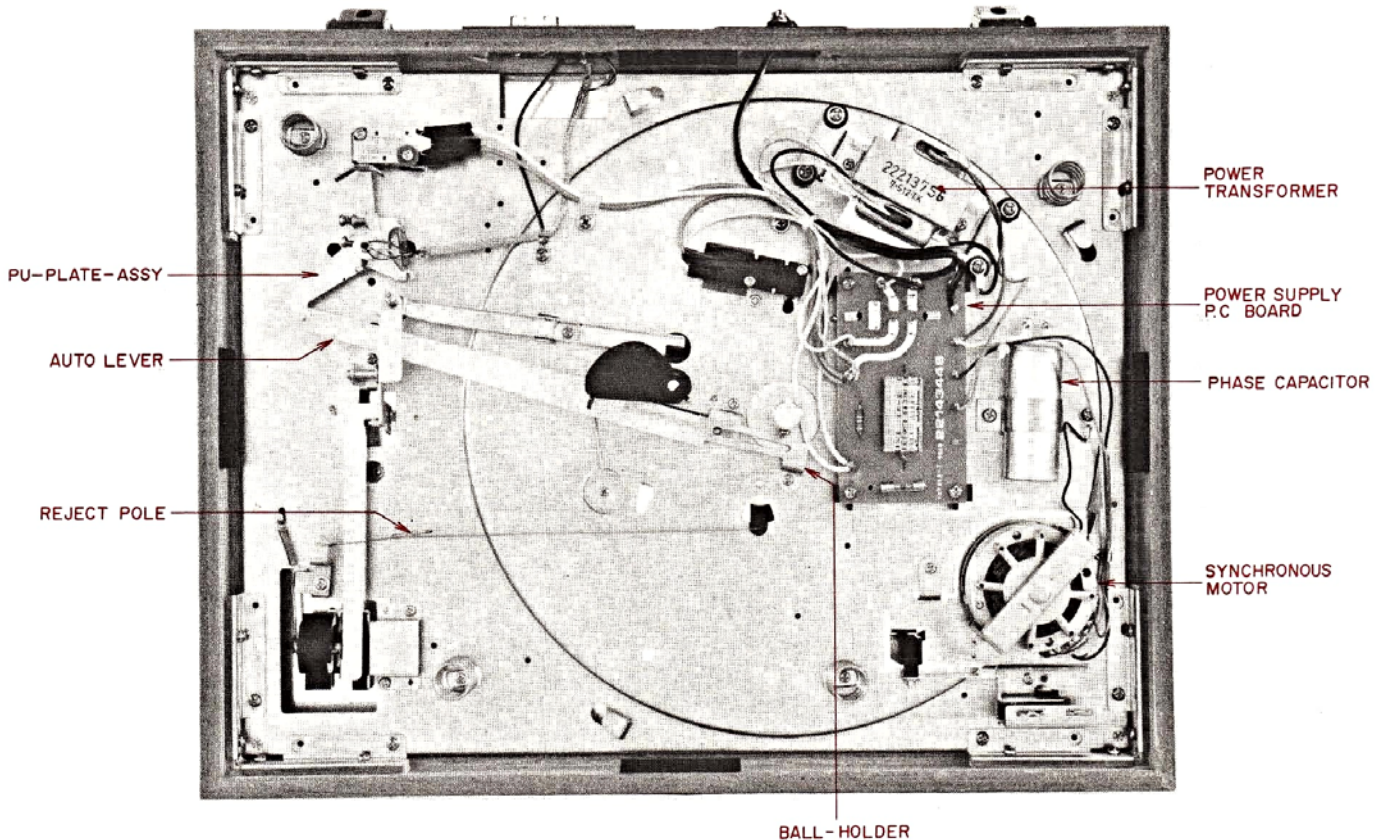
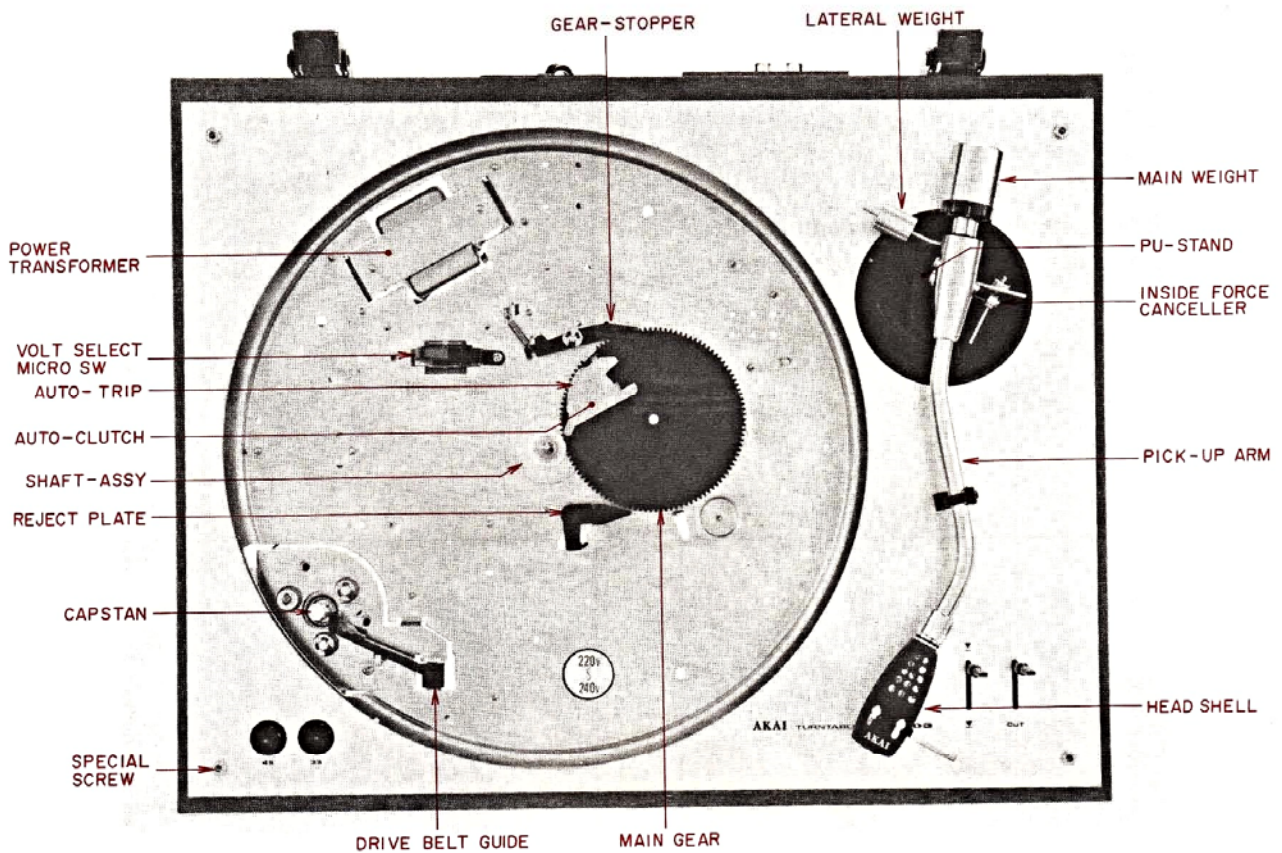

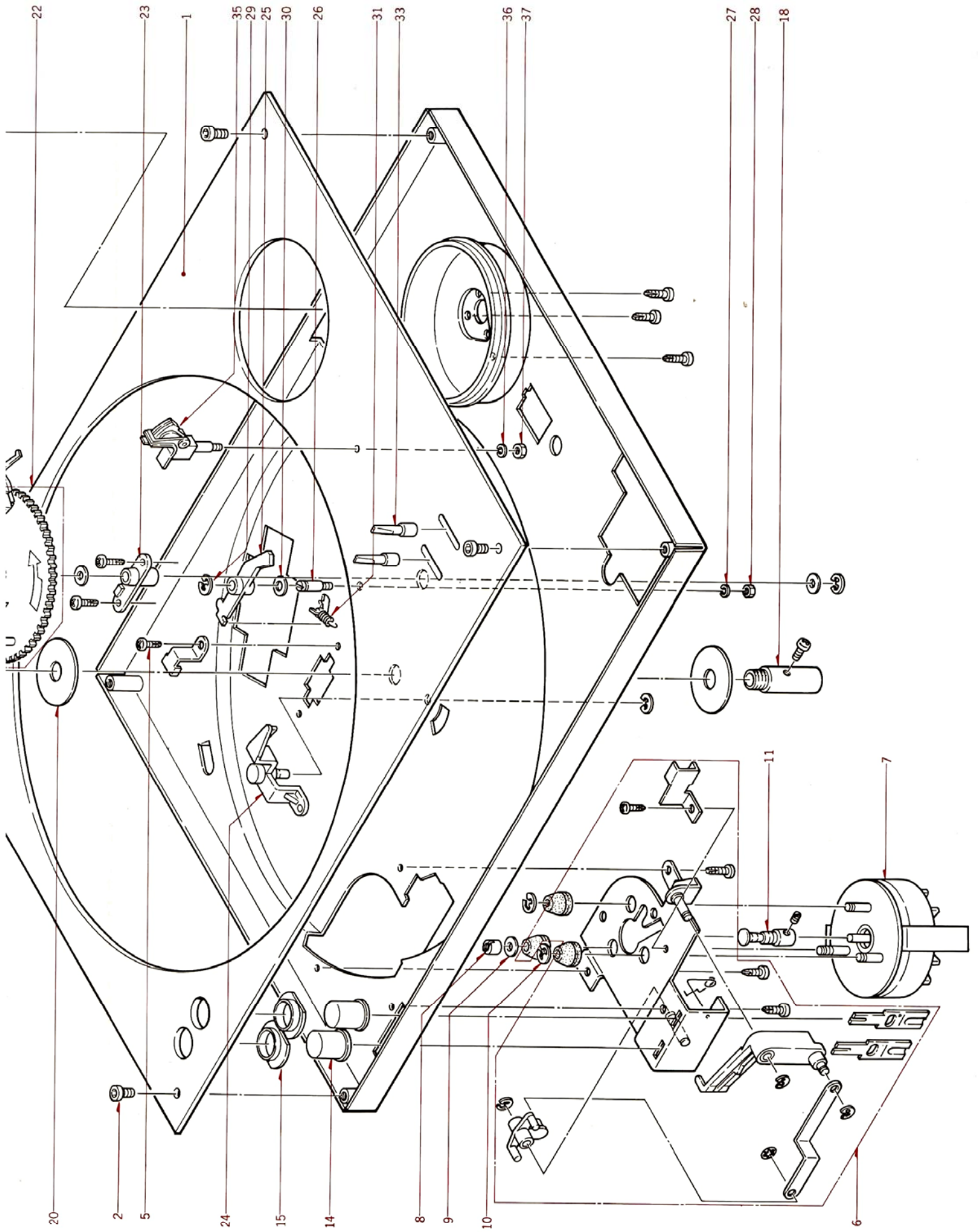

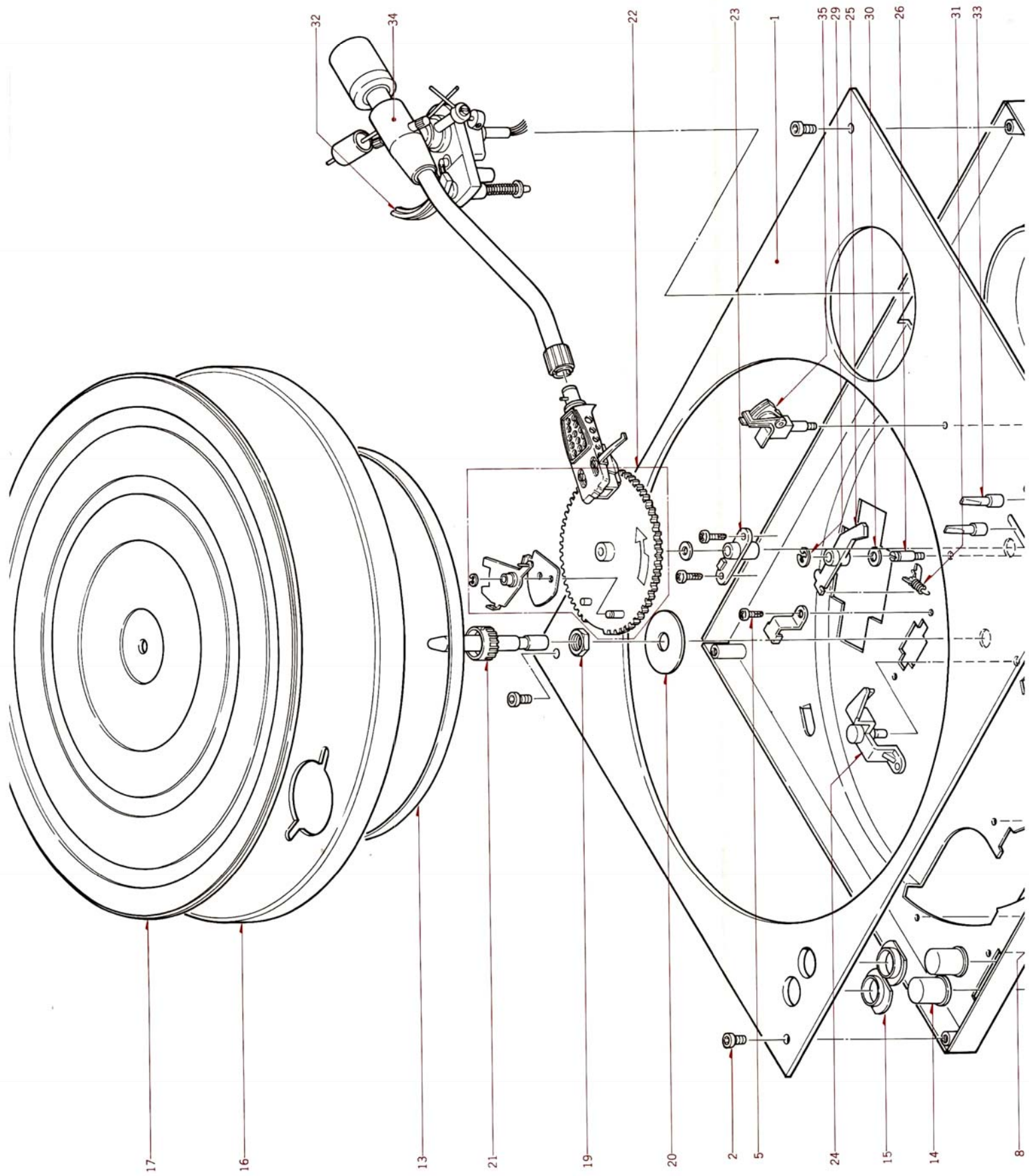



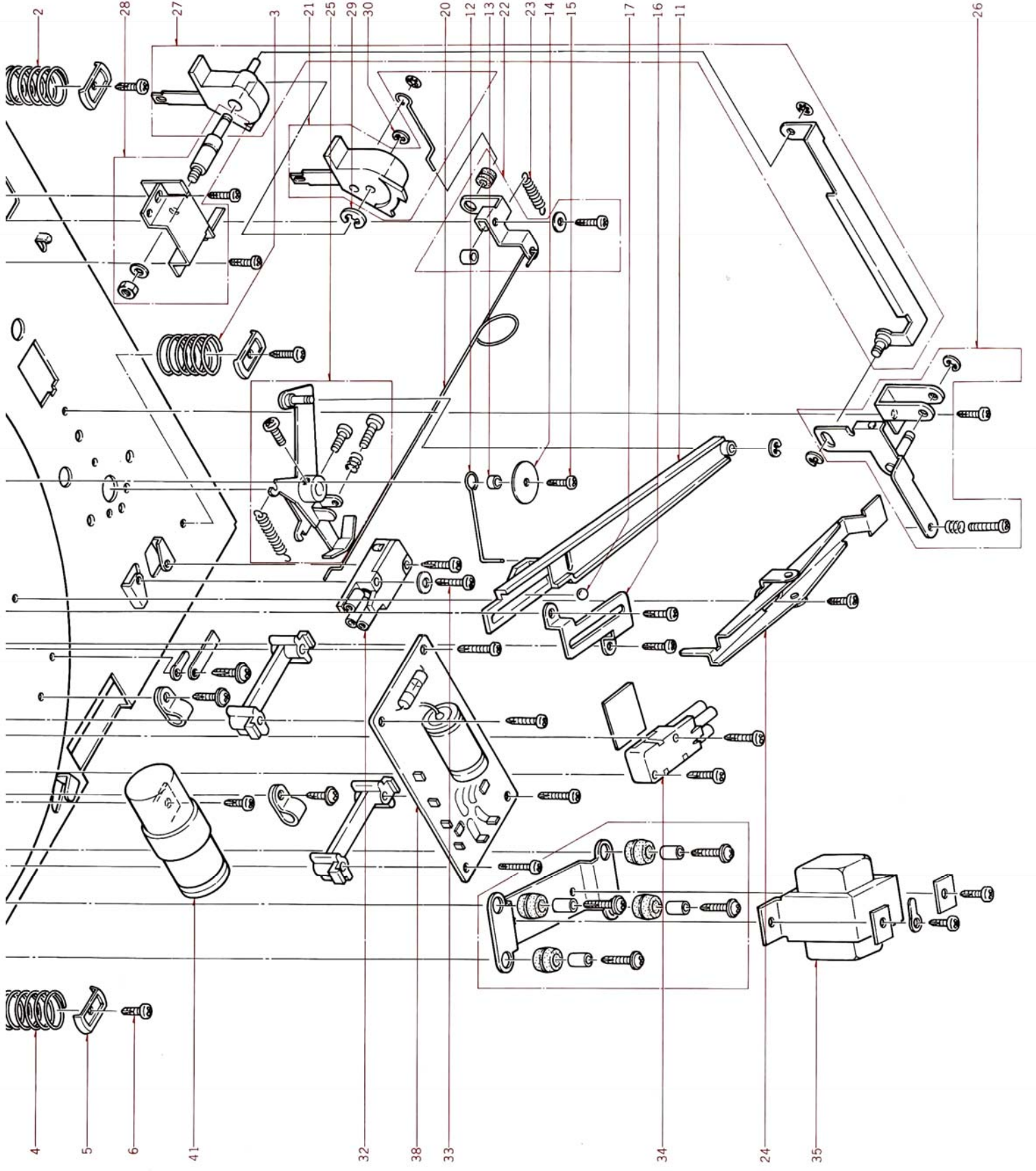

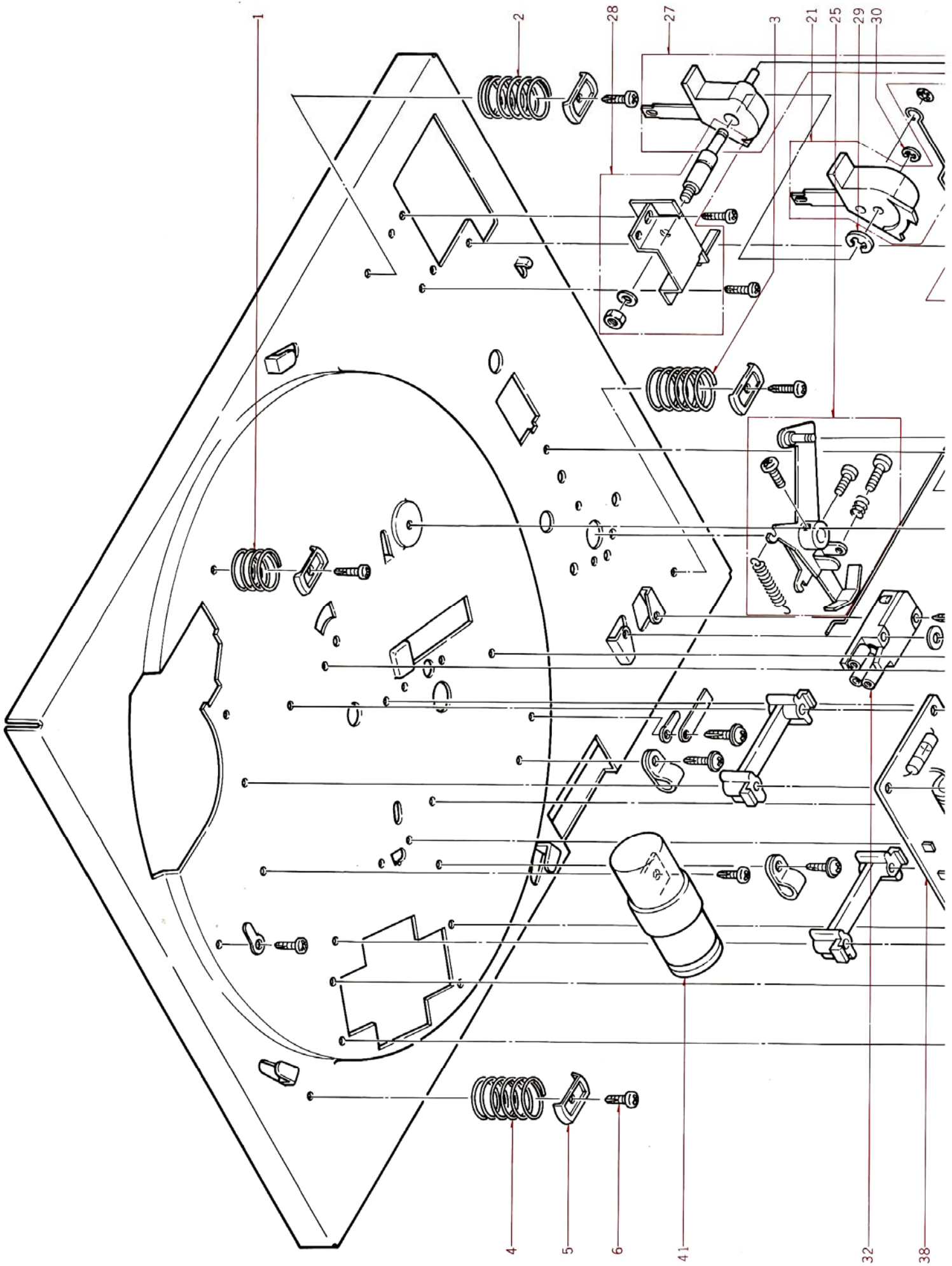

## IV. VARIOUS ADJUSTMENT

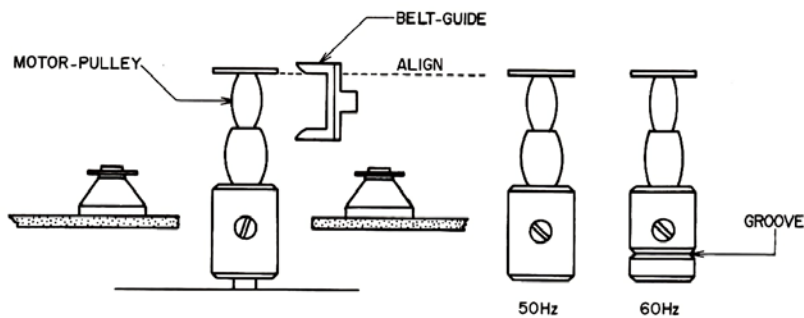
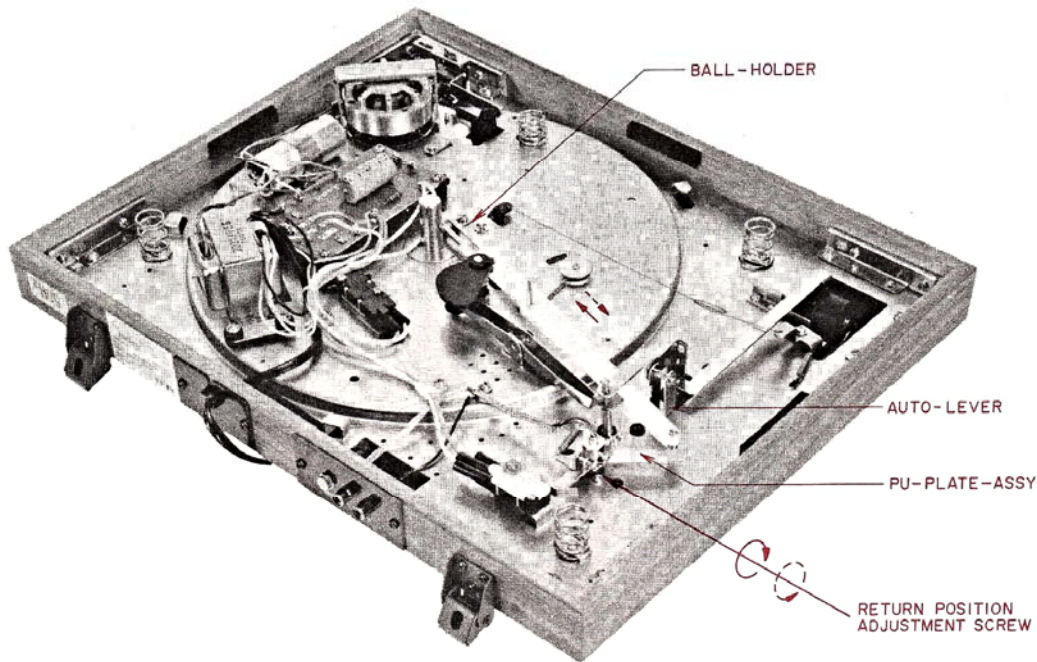

Fig. 2 Motor Pulley Change

All of the stationary parts of this machine are ideally adjusted prior to shipment. However, the following adjustments are necessary according to circumstances involving usage.

### 1. RETURN POSITION ADJUSTMENT

After removal of the BOTTOM-COVER from the player body, adjust return position adjustment screw located on the reverse side of the PU Arm with a plus driver.

As shown in Fig. 1, when the adjustment screw is turned to the right, the return position is slowed (inside circumference approach) and when the adjustment screw is turned to the left, the return position is speeded up (outside circumference approach).

(When the adjustment screw is turned 1 revolution, the position of the PU Arm stylus tip is changed by about 8.5 mm)

Always confirm this adjustment with a JIS specification 30 cm LP record. Also with turntable removed, confirm that the AUTO-CLUTCH begins to move out when the PU Arm stylus tip is 64 mm (R) to 70 mm (R) from the turntable shaft center.

#### CAUTION:

If adjustment cannot be made without turning the

adjustment screw more than 2 revolutions, because this is likely to be caused by improper installment position of PU-PLATE-ASSY., AUTO-CLUTCH and AUTO-TRIP etc. (by position of other parts) check these points.

Also after adjustment, be sure to re-install BOTTOM-COVER and return installment screws to former position and tighten.

### 2. CYCLE CHANGE

#### (MOTOR PULLEY CHANGE)

Cycle change is effected by changing the motor pulley. 50 and 60 Hz differentiation can be determined by the groove on the 60 Hz pulley as shown in Fig. 2.

While viewing horizontally as shown in figure, install so that the lower part of the motor pulley brim and the lower surface of the BELT-GUIDE (part indicated in figure) are aligned.

(Set Speed Selector to 33 rpm position)

When the player is turned ON and the turntable rotates, if a rubbing noise from the belt can be heard, (except while switching) and operation is not smooth, further adjust pulley height by moving up and down slightly and position for best adjustment.

NOTE: Set speed selector to "33" position.

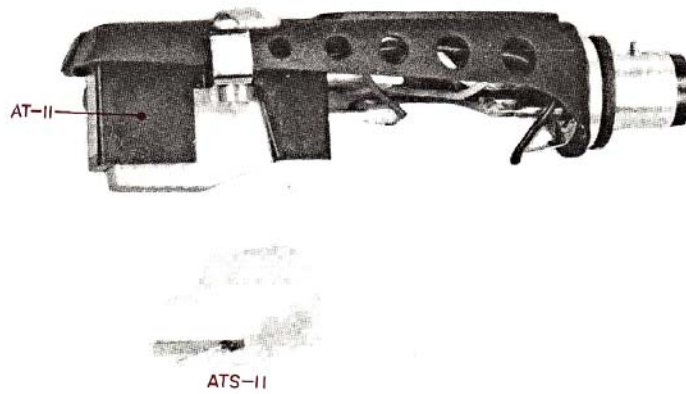

Fig. 4

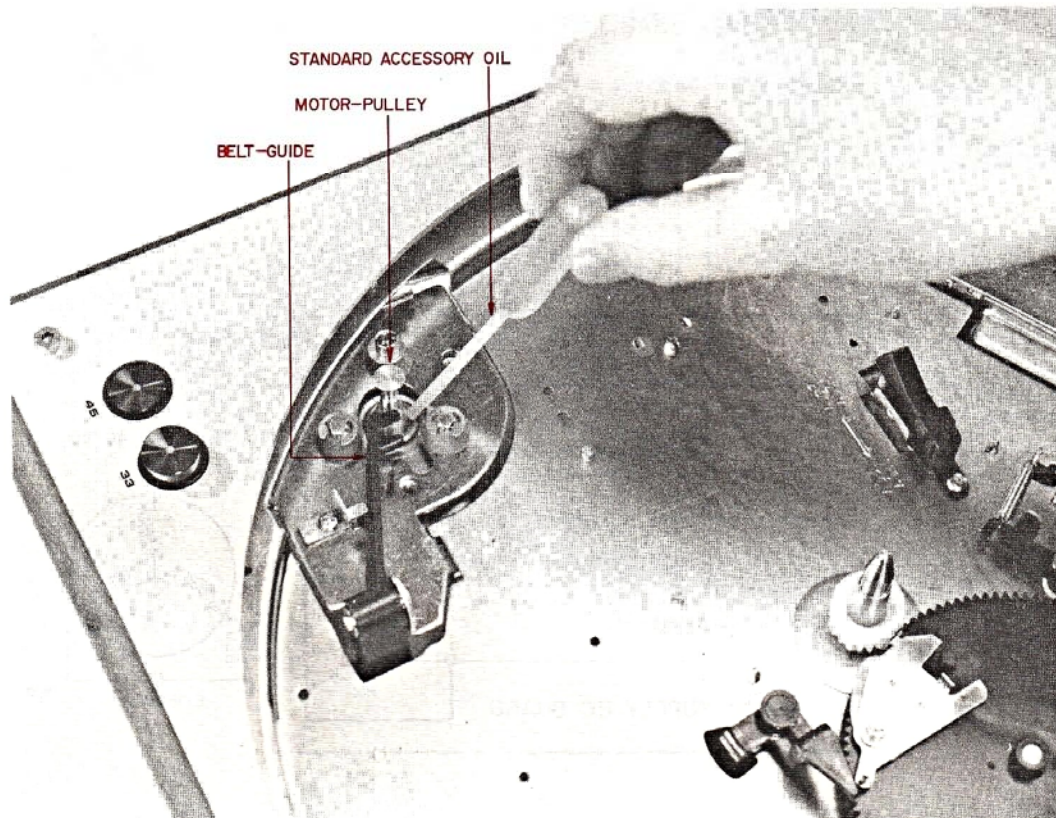

Fig. 5

## 2. LIFE OF STYLUS

The lifetime of the stylus is about 500 hrs. of use (both sides of about 500 30 cm LP records).

If the stylus becomes old, because the record will be damaged and tone quality will become inferior, be sure to replace as soon as is needed. The stylus will wear especially fast and record surface will be scratched if records on which dust is allowed to accumulate are played. Therefore, please be sure to keep record clean by wiping and cleaning the record grooves with water soaked gauze. Also if dust adheres to the turntable mat as this will cause the record to become dirty easily, the mat should also be kept clean.

## 3. STYLUS CHANGE

When replacing stylus be sure that the stylus holder is inserted properly so that it is firmly set in cartridge. The replacement stylus for this machine is marketed with the stylus and stylus holder as a single structure.

Use only model ATS-11 stylus which is for use in Model AT-11 Cartridge.

## 4. LUBRICATION

Because for rotating parts and parts which rub together during operation, oilless metal and the best grease is used, your machine will not need lubrication for some time. Oil at points shown in illustration about once per year using standard accessory oil. In case you have run out of standard accessory oil, use #60 spindle oil on a high grade machine oil. If used continually for business purposes, etc., oil about once or twice per month.

### CAUTION:

Following lubrication, because oil will adhere to the drive belt and pulley and to the turntable etc., wipe the oil off of these parts with a cloth to which a little carbon tetrachloride or thinner (benzine can be also be used) has been applied.

# BLOCK DIAGRAM

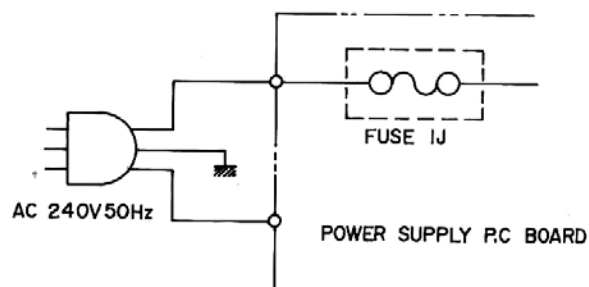
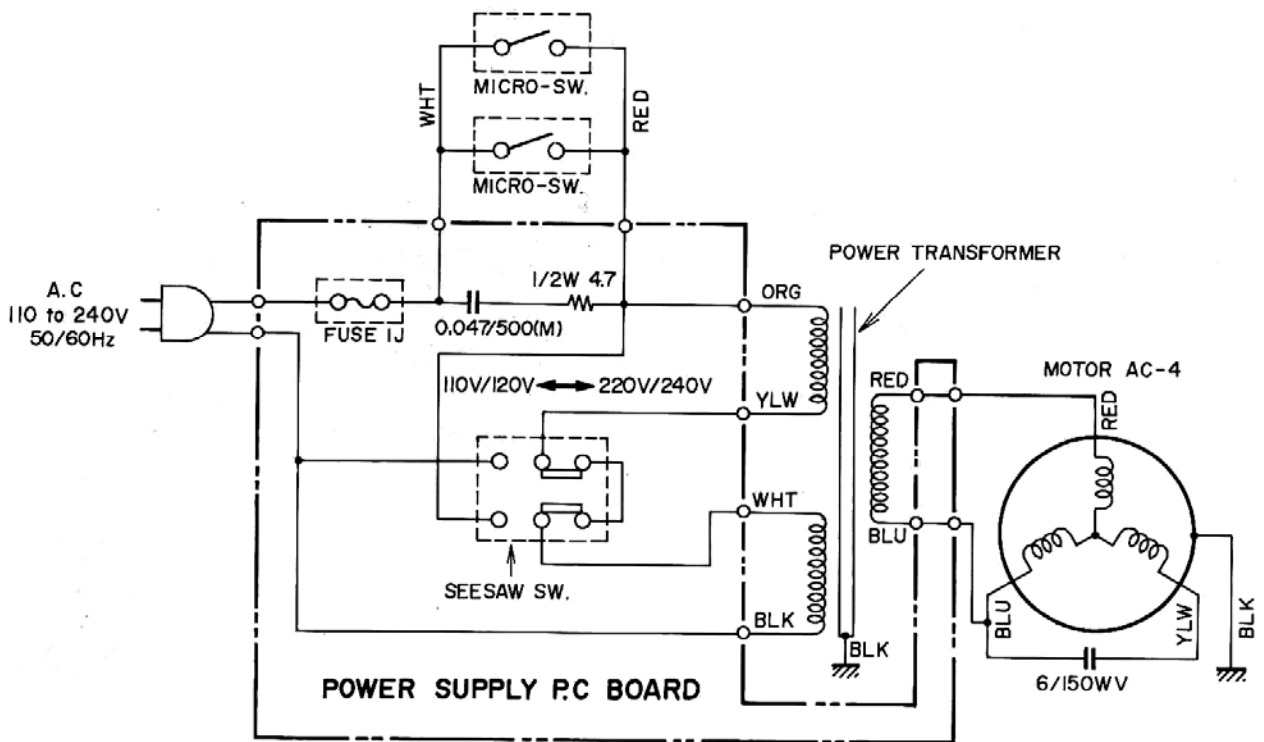
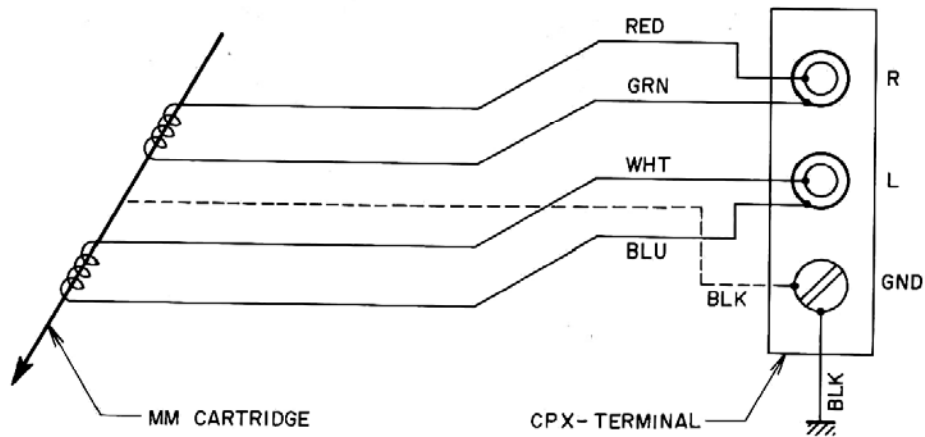

# VII. TROUBLE SHOOTING CHART

CONDITION	EXPLANATION	SOURCE AND SYMPTON	COUNTERMEASURE
Poor tone quality	1. Distortion (when using a new quality record)	<p>Faulty cartridge Distortion persists after changing stylus and confirming normal pick up arm operation. (Amp, speaker normal)</p> <p>Worn stylus Cracking sound even when playing new record. Especially vague at high range.</p> <p>Stylus pressure inadequate Stylus sinks too far into cartridge body during record playback (too much pressure). Sound completely distorted. Needle jumps (insufficient pressure).</p> <p>Bent Stylus A crunching sound exists and the level of right and left differs greatly. Also loss in directional sensitivity. Sudden change in sound level.</p> <p>Dust adhering to stylus tip. Sound is vague or distortion exists.</p>	<p>Replace cartridge.</p> <p>Replace stylus.</p> <p>Readjust stylus pressure.</p> <p>Replace stylus.</p> <p>Clean stylus tip.</p>
	2. Hum Noise	<p>Lead wire from pick up and power source wiring is too close together. Hum is altered by changing position of lead wire.</p> <p>Insufficiently grounded When pick up arm or player body is touched with your hand, hum noise increases. No sound from side (or both channels) and only a hum is emitted.</p>	<p>Check wire and correct.</p> <p>Check amp input grounding from cartridge. Check player and amp connection, and pin plug cord connection perfectly.</p>
	3. Left/Right sound separation poor	<p>Faulty cartridge Using a monaural record, left right sound scatters and is not emitted from the center. (Amp, speaker connections are correct). (Confirm that the plus &amp; minus terminals are not reversed on one side at cartridge output pin and shell pin connection)</p>	<p>Replace cartridge.</p>
	4. Distortion at one channel only	<p>Bent pick up head Observe head during record performance.</p> <p>Pick up arm rotating shaft faulty Check pick up arm side pressure. At zero balance, arm does not move smoothly by means of inside force canceller.</p> <p>Faulty operation of AUTO-LEVER Is there sufficient loose play between AUTO-LEVER and PU-PLATE ASSY connection part? Are these parts bent? Is steel ball movement smooth?</p> <p>Trip function faulty Is there sufficient loose play at AUTO-TRIP and AUTO-CLUTCH installation? Are these parts bent?</p>	<p>Replace pick-up arm.</p> <p>Replace pick-up arm.</p> <p>Straighten or replace.</p> <p>Straighten or replace.</p>
	5. Absolutely no sound	<p>Pin plug cord is disconnected or solder has come off of lead wire connection. Confirm connections with tester.</p> <p>Shorted or wire inside cartridge Check cartridge terminal DC resistance with tester. (L-ch, R-ch)</p>	<p>Correct.</p> <p>Replace cartridge.</p>

CONDITION	EXPLANATION	SOURCE AND SYMPTON	COUNTERMEASURE
Unusual noise	1. Mechanical noise (direct noise)	<p>Contact of GUIDE BELT and BELT Relative height of MOTOR-PULLEY and GUIDE BELT poor. (Remove turntable and check)</p> <p>Vibration interference from Motor (MOTOR AC-4) rotation. During motor rotation, if player panel or pick-up arm is touched with your hand, vibration is evident. Direct rotating noise is audible.</p> <p>Abnormal automatic mechanism noise Check for irregular shape of AUTO-CLUTCH and AUTO-TRIP, GEAR-STOPPER needs greasing.</p> <p>Variation in MOTOR-PULLEY During revolutions, check MOTOR-PULLEY vibration, form variation, and eccentricity.</p>	<p>Adjust MOTOR PULLEY height.</p> <p>Adjust motor installation.</p> <p>Replace Motor. Correct or replace.</p> <p>Grease.</p> <p>Replace MOTOR PULLEY.</p>
	2. Electrical noise (from speaker)	<p>Lead wire leak or pin plug cord connection faulty. Sometimes shock noise and hum is emitted. Interference when lead wire is touched. No noise periodically. Check with Tester.</p> <p>Defective cartridge Interference when upper part of shell is lightly tapped.</p> <p>Rumbling noise from motor (MOTOR AC-4) rotation vibration. During motor revolutions, vibration occurs when player mount table and arm is touched with your hand. (Confirm that shipping screws have been removed).</p>	<p>Correct lead wire wiring. Make proper pin, plug cord connection.</p> <p>Replace cartridge.</p> <p>Adjust motor installation.</p> <p>Replace RB-CUSHION.</p>
Turntable does not rotate (or rotation is unstable).	1. Electrical circuit problem	<p>Loose or broken lead wire Faulty soldering Faulty switch (MICRO-SW) Fuse blown Check with tester according to schematic diagram.</p>	<p>Correct wiring.</p> <p>Replace switch. Replace fuse.</p>
	2. MOTOR out of order (MOTOR AC-4)	<p>Coil open Check coil lead through with Tester. Rotor shaft needs oil or shaft is being caught by something. Rotate rotor by hand and check.</p>	<p>Replace motor.</p> <p>Clean around rotating shaft and oil.</p>
	3. Table shaft out of order	<p>Table shaft and table bearing defective When turntable in rotated by hand it seems heavy. There is a noise as soon as the turntable is stopped. Too much rattle. (Remove belt &amp; check)</p> <p>Needs oil Irregular noise when turntable is rotated by hand.</p>	<p>Replace table shaft, bearing</p> <p>Grease.</p>
	4. Speed change mechanism defective	<p>Relative position of BELT and MOTOR PULLEY, BELT-GUIDE poor. Belt rubbing noise. Belt does not come to specified position (drum like part) of MOTOR PULLEY. Speed change is not smooth.</p>	<p>Adjust MOTOR PULLEY height. Adjust SPECIAL-NUT</p>
	5. Revolutions too slow or uneven.	<p>(After confirming distortion in Item 4) Inferior BELT. Is contact side of belt inferior? Discolored or misshapen? Check for belt stretch.</p>	<p>Replace belt.</p>

CONDITION	EXPLANATION	SOURCE AND SYMPTON	COUNTERMEASURE
Automatic mechanism does not function.	1. Unstable return	<p>PU-PLATE-ASSY installation loose Are the two installation screws perfectly tight?</p> <p>PU-PLATE-ASSY coil spring has come off. Are both ends of the spring fastened to hook aperture?</p> <p>Faulty PU-PLATE-ASSY Is coil spring having any effect? Is it too loose or bent? Is operation smooth where the two plates are hinged together?</p> <p>Mutual relativity of PU-PLATE-ASSY and AUTO-LEVER unsuitable. Is installment position of PU-PLATE-ASSY correct? Is there proper loose play where PU-PLATE-ASSY and AUTO LEVER are linked?</p> <p>AUTO-LEVER faulty Irregular noise when PU ARM is moved (rubbing noise). Is it bent? No loose play at all where PU-PLATE-ASSY is linked or too much loose play.</p> <p>5/32" STEEL BALL is out of place Is the STEEL BALL between AUTO LEVER and BALL HOLDER in place?</p> <p>AUTO-TRIP faulty Movement is not smooth when PU ARM is moved lightly toward inner circumference. Is it bent, warped, or does it have uneven edges? Check especially for misshapen skirt part and check condition of tip part.</p> <p>AUTO-CLUTCH faulty (insufficient kickback volume) Is it bent, warped, or misshapen? Are there uneven edges at parts influenced by operating function?</p> <p>AUTO-TRIP and AUTO-CLUTCH relativity unsuitable When PU ARM is moved lightly toward inner circumference does AUTO CLUTCH ride on AUTO-TRIP and move together? Is movement smooth?</p>	<p>Tighten installation screws.</p> <p>Fasten coil spring.</p> <p>Replace PU-PLATE-ASSY</p> <p>Adjust PU-PLATE-ASSY according to installation regulations.</p> <p>Replace AUTO-LEVER.</p> <p>If 5/32" STEEL BALL has come out, reinsert.</p> <p>Replace AUTO-TRIP.</p> <p>Adjust to specified kick-back volume (0.7) or replace.</p> <p>Replace both AUTO-TRIP and AUTO-CLUTCH.</p>
	2. Does not return	<p>Mutual relativity of PU-PLATE-ASSY and AUTO-LEVER unsuitable AUTO-CLUTCH does not move out even when PU-ARM approaches 130° position from table shaft center.</p> <p>PU-PLATE-ASSY installation loose Is installation screw perfectly tight?</p> <p>Mutual relativity of AUTO-TRIP and AUTO-LEVER unsuitable. Is skirt part of AUTO-TRIP misshapen? Is tip part of AUTO-LEVER misshapen?</p> <p>GEAR-STOPPER does not work properly Is coil spring properly installed? When MAIN GEAR is rotated, it is unusually heavy (RETURN-ROD bent).</p> <p>RETURN-CAM improperly installed. Confirm.</p> <p>Protruding part on TABLE-SHAFT-ASSY causing over kick-back. Check whether stand-up part of AUTO-CLUTCH is misshapen or has uneven edges, etc.</p>	<p>Adjust return position with Return Adjustment screw.</p> <p>Tighten installation screw.</p> <p>Repair bent or misshapen parts of both AUTO-TRIP and AUTO-LEVER or replace.</p> <p>Install coil spring properly or straighten bent RETURN-ROD.</p> <p>Properly install RETURN-CAM.</p> <p>Replace CLUTCH-ASSY.</p>



CONDITION	EXPLANATION	SOURCE AND SYMPTON	COUNTERMEASURE
	<p>3. POWER SOURCE is not turned off even when return function has ended. (Turntable continues to rotate)</p>	<p>GEAR-STOPPER faulty operation.  Is GEAR-STOPPER coil spring correctly installed?  Is STOPPER-SHAFT bent?  PU-PLATE-ASSY installation angle unsuitable.</p> <p>The part moving to MICRO-SW is not coming to established position.  MICRO-SW faulty or wrong wiring.  Short.  Check with tester according to schematic diagram.</p> <p>GEAR-STOPPER coil spring too strong.  Continuous rotation of MAIN GEAR (AUTO-CLUTCH projecting toward shaft table caused from stopper gear operation shock).</p> <p>REJECT-POLE shorter than specified length (misshapen).  REJECT-LEVER-ASSY constantly touching AUTO-CLUTCH.</p>	<p>Correct coil spring installation.  Replace STOPPER-SHAFT or GEAR-STOPPER.  Correct installation angle of PU-PLATE-ASSY.  Readjust return position.</p> <p>Replace MICRO-SW.  Correct wiring.</p> <p>Check for slight coil spring stretch.  Replace spring.</p> <p>Make the V bend of REJECT-POLE slightly wider.</p>
	<p>4. Does not return when CUT KNOB is manipulated. (Distribution 1 to 3 is sufficient)</p>	<p>REJECT-POLE stretched (misshapen)  When knob is manipulated REJECT-LEVER-ASSY does not sufficiently move CLUTCH ASSY.  REJECT-PLATE Separation.  Make visual check.</p>	<p>Make the V bend of REJECT-POLE slightly narrower.</p> <p>Install properly</p>
	<p>5. During performance, PU Arm fails to continue advancement toward center (Needle jumps).</p>	<p>Mutual relativity of PU-PLATE-ASSY and AUTO-LEVER unsuitable.  Is there sufficient play where PU-PLATE-ASSY and AUTO-LEVER is linked?  Is steel ball inside BALL-HOLDER moving smoothly?  Is AUTO-LEVER misshapen?  Has steel ball fallen out?</p> <p>PU ARM Bearing faulty  PU ARM horizontal angle incorrect even when PU-PLATE-ASSY is removed.  AUTO-CLUTCH and AUTO-TRIP not operating properly.  (Movement heavy)  Is there foreign matter or oil adhering to mutual contact surfaces? Are these parts misshapen or do they have uneven edges?</p> <p>Insufficient stylus pressure  PU Arm is unusually light when touched with finger. (Playback sound vague or distorted).</p>	<p>Correctly install PU-PLATE-ASSY.  Replace AUTO-LEVER.</p> <p>Re-insert 5/32".  STEEL BALL into place.</p> <p>Replace PU Arm.</p> <p>Clean or replace.</p> <p>Readjust to specified stylus pressure.</p>
	<p>6. Returns during performance (using JIS specs. record).</p>	<p>Stand-up part of AUTO-CLUTCH misshapen or has uneven edges.  Kick-back insufficient.  Check for misshapen or uneven edges.  Foreign matter or oil between AUTO-CLUTCH and AUTO-TRIP.  Is movement smooth when PU Arm is moved lightly toward inner circumference (130φ vicinity)?</p>	<p>Readjust to regain proper kick-back (0.7) or replace.</p> <p>Clean.</p>
<p>Faulty operation of Hand operated Lifter.</p>	<p>1. Lifter does not operate either when set UP or DOWN.</p>	<p>Faulty adjustment  Adjustment Screws and are not working effectively.  LIFT-LEVER-ASSY does not operate properly.  Is installation screw loose?  Is P-SPRING misshapen or installation loose?</p>	<p>Re-adjust.</p> <p>Tighten.</p> <p>Replace.</p>

CONDITION	EXPLANATION	SOURCE AND SYMPTON	COUNTERMEASURE
	<p>2. Lifter does not operate when set to DOWN position.</p>	<p>Inner part of LIFT-SHAFT needs oil. Inferior. Remove LIFT-SHAFT and check.</p> <p>NOTE: THERE ARE CASES WHEREIN AFTER HAVING THE LIFTER AT UP POSITION FOR A LONG PERIOD OF TIME, WHEN IT IS FIRST BROUGHT TO DOWN DIRECTION, MOVEMENT IS RELATIVELY SLOW (SOMETIMES STOPS TEMPORARILY), BUT THIS IS NORMAL AND DOES NOT MEAN IT IS OUT OF ORDER.</p>	<p>Lubricate with specified oil (Silicon oil 200,000 CS)</p>
	<p>3. No UP/DOWN moderation when lifter is manipulated (Springs back at UP positions).</p>	<p>Steel ball inside LIFT-CAM has come out. Is P-SPRING damaged of misshapen? Confirm STEEL BALL position. Adjustment faulty Setting of adjustment screws unsuitable (too tight).</p>	<p>Replace P-SPRING. Re-insert steel ball bearing.  Readjust.</p>